

VTX: A-SERIES

SYSTEM SOLUTIONS

A12





VTX: A-SERIES SYSTEM SOLUTIONS

THE COMPLETE TOUR SOUND SOLUTION

Of all the achievements JBL has made over the years, the VTX A-Series stands as a milestone in the practical application of creative engineering. The next generation in line arrays, VTX heralds a new era in performance, system integration and user friendliness. Supported by multiple patents in driver, waveguide and suspension technology, VTX is also supported by technologies from the HARMAN Professional family of brands for amplification, DSP, control and system management. In addition to high-performance components, VTX is backed by JBL's engineering support—the human factor and technical tools that are key to the proper specification and configuration of a VTX system in any venue, anywhere in the world.

The VTX A-Series is a result of JBL's continued effort to deliver more powerful, more compact, lightweight and flexible sound reinforcement systems. Designed for portable and fixed-venue system operators alike, VTX features JBL's legendary sound quality coupled with the most advanced sound reinforcement technology and support available. As a member of the HARMAN group, JBL draws from the expertise and integration of the entire range of HARMAN Professional audio technologies. So, in addition to the best sound possible, VTX offers efficient and intuitive setup, tuning, networking and control to provide a truly professional and advanced system solution.

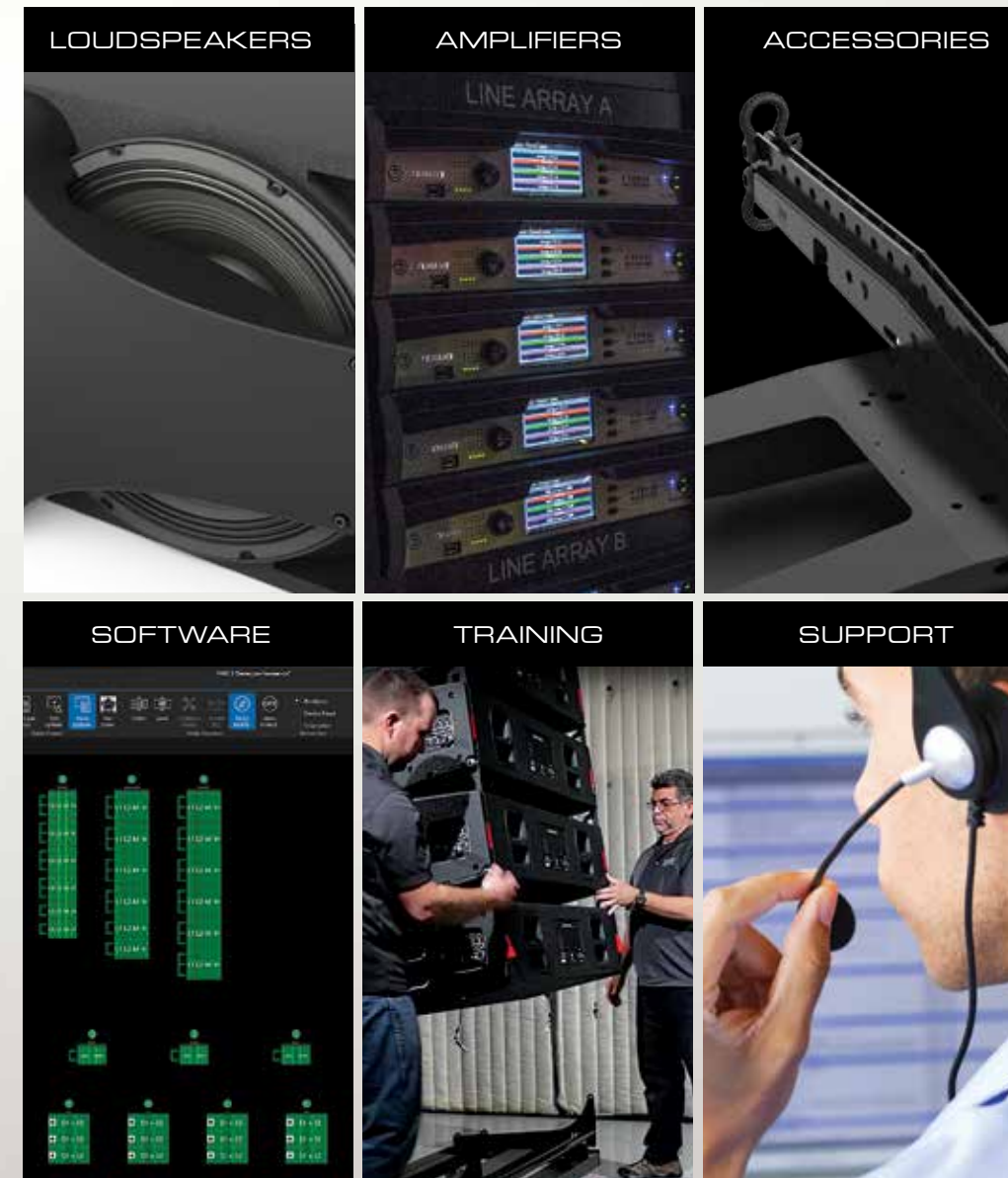

ENGINEERED FOR PERFORMANCE

The VTX A12 is a next-generation line array system that delivers JBL Professional's flagship loudspeaker technology in a compact, lightweight solution for mid- to large-size touring applications and high-end fixed installations. The VTX A12 was designed to address the diverse sound reinforcement needs of rental companies, installation houses, FOH engineers and tour sound production crews. At the core of the A12 is the latest in JBL transducer and waveguide technology, delivering unmatched performance, sound quality and reliability. A patented auto-locking rigging system streamlines deployment, while a comprehensive suite of accessories allows for a number of deployment configurations. Its design and manufacturing refinements maximize longevity and versatility while minimizing size and dramatically reducing weight. Like all other VTX products, A-Series cabinets are made out of the highest quality materials and finished with JBL DuraFlex™ impact-resistant black coating. And of course, VTX A12 has gone through JBL's rigorous 100-hour, full power torture test to ensure you reliable performance night after night.

VTX:A-SERIES
SYSTEM SOLUTIONS

A12



JBL DURAFLEX™ FINISH

JBL RBI + LF DIRECTIVITY CONTROL DEVICES

JBL SLIPSTREAM™ FLARED PORTS

2 X JBL 2265 LOW-FREQUENCY WOOFERS

4 X JBL 2165 MID-FREQUENCY WOOFERS

3 X JBL 2423 HF-DRIVERS + WAVEGUIDE

AUTO-LOCKING SUSPENSION SYSTEM



KEY BENEFITS

: Next-Gen JBL Loudspeaker Technology

: Fast Innovative Rigging

: Full Set of Accessories

: JBL Transducers

: Lightweight Truck-Friendliness

: Comprehensive Software Suite

JBL TRANSDUCERS

Transducer technology is truly the foundation of every high-performance sound system. JBL has long been identified with innovation in transducer design and manufacturing, holding scores of patents and is considered to be the true performance benchmark for the audio industry. JBL engineers continue to break ground on new and better ways to design transducers, utilizing the most up-to-date computer simulation technologies, pioneering rapid prototyping techniques and continuously innovating on the latest in material science.

Every component inside the VTX A-Series loudspeakers was custom-designed to match the unique requirements of the system. Together, the completely redesigned low-, mid- and high-frequency sections deliver the highest output per weight, improved linearity and minimal power-compression.

HIGH-FREQUENCY TRANSDUCER

INTEGRATED HIGH-FREQUENCY SECTION

VTX A-Series full-range products feature an innovative HF section that integrates the driver, phasing-plug and waveguide into a single device. At the core of the new device is a lightweight, polymer, annular diaphragm that improves high-frequency extension by reducing diaphragm mass. The V-shaped geometry of the annular diaphragm reduces breakup modes, eliminating time smear and reducing distortion. A unique "meandering shaped" compression driver exit allows for improved diaphragm sampling and produces a more linear frequency response with less DSP correction. Directly connected to the meandering exit is the plane-wave generator that time-manipulates exit paths and turns the HF wavefront into a precisely-timed plane wave.

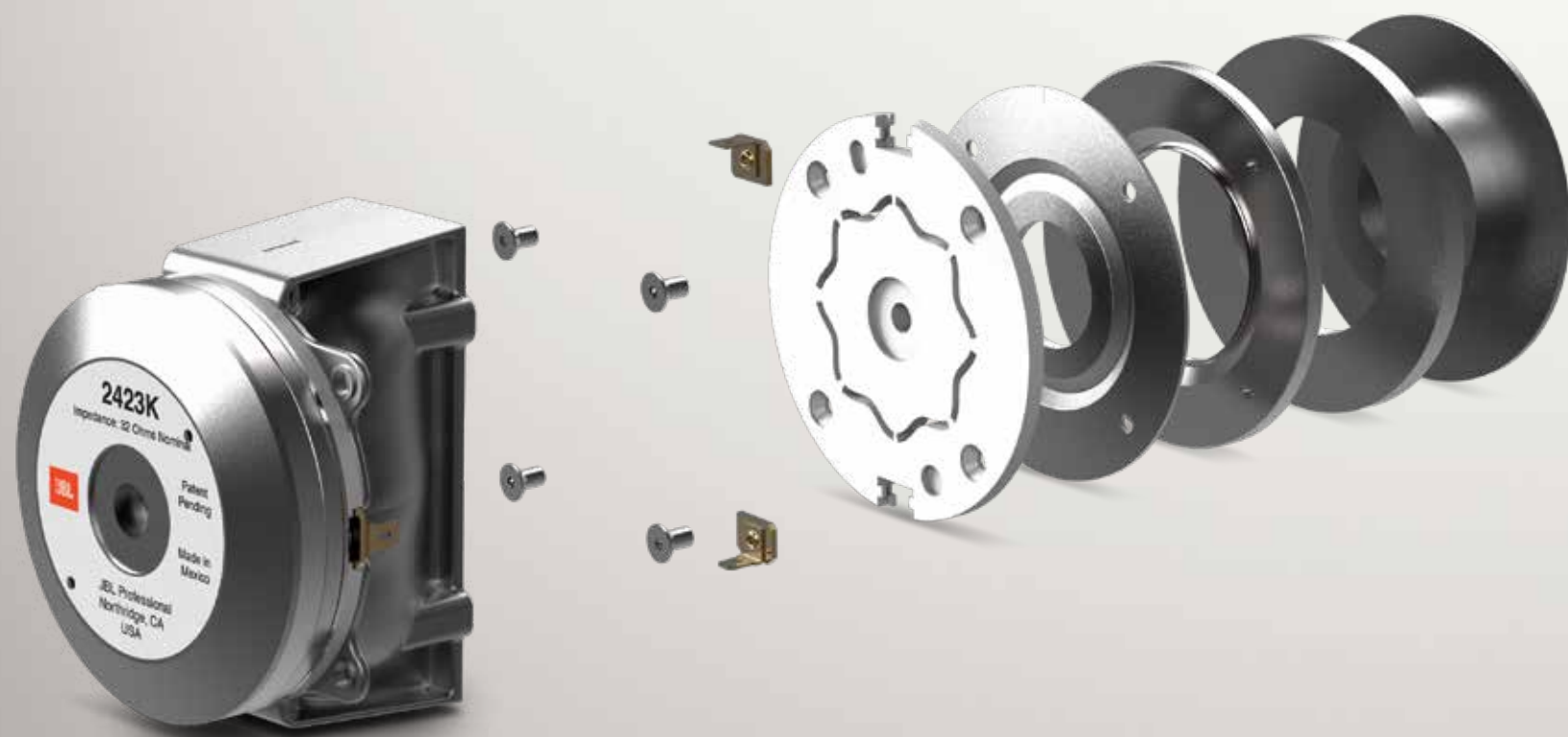

DIFFERENTIAL DRIVE®

At the heart of JBL's exclusive Differential Drive technology is a dual voice-coil, dual-neo-magnet arrangement that delivers better heat dissipation, lower power compression and higher dynamic range versus conventional single-coil designs. Heat sinks are integrated into the driver's cast aluminum frame and the neodymium magnets are placed inside the driver's dual voice coil assembly, completing the magnetic circuit without the heavy surrounding steel structure found in conventional drivers.

All critical performance parameters are greatly enhanced including better frequency response, higher power output, and lower distortion—while dramatically reducing driver weight.



PRODUCT OVERVIEWS

VTX A12



The VTX A12 is a 3-way line array element designed for mid- to large-size touring applications and high-end fixed installations. The VTX A12 produces a 90-degree horizontal pattern down to 250Hz and uses two 12" Differential Drive LF woofers, four 5.5" Differential Drive MF drivers and three 2" HF compression drivers. The symmetrically arranged transducers produce a 46Hz to 19kHz system frequency response. The patented auto-locking suspension system allows for up to twenty-four VTX A12 cabinets to be flown in a single array with splay angles between cabinets ranging from 0.25° to 10° in 0.25° resolution, depending on the position. The enclosure is made from 18mm, 11-ply Finnish birch plywood and finished with JBL's DuraFlex™ impact-resistant black coating. A 14-gauge, full-face weather-resistant grill is used to protect the transducers and four high-quality VTX handles with rubber-over molded grips are used for comfortable handling.

Frequency Response
46 Hz – 19 kHz (Preset: VTX A12)

Coverage Pattern
Horizontal: 90 degrees nominal
(250Hz – 18kHz)

Maximum Peak Output*
146 dB (Preset: VTX A12)

System Processing
Crown Audio I-Tech HD Series,
Crown Audio I-Tech 4x3500HD

Nominal Impedance
LF: 8Ω, LF: 8Ω, MF: 8Ω HF: 8Ω

Dimensions (H x W x D)
330.2mm x 1117.6mm x 495.3mm
(13.0in x 44.0in x 19.5in)

Weight
60.8 kg (134.0 lbs)

VTX A12W



Like the VTX A12, The VTX A12W is also a 3-way line array element designed for mid- to large-size touring applications and high-end fixed applications. All specifications are identical between the two products, with the exception of the horizontal dispersion pattern. Designed for applications that require wider horizontal coverage, the A12W provides 120-degree coverage down to 250Hz, as opposed to the 90-degree coverage offered in the VTX A12. With identical physical characteristics, weight, rigging mechanisms and suspension systems, the VTX A12 and the VTX A12W can be flown independently or in mixed configurations providing more flexibility in system design.

Frequency Response
46 Hz – 19 kHz (Preset: VTX A12W)

Coverage Pattern
Horizontal = 120 degrees nominal
(250Hz – 16kHz)

Maximum Peak Output*
146 dB (Preset: VTX A12W)

System Processing
Crown Audio I-Tech 12000HD
Crown Audio I-Tech 4x3500HD

Nominal Impedance
LF: 8Ω, LF: 8Ω, MF: 8Ω HF: 8Ω

Dimensions (H x W x D)
330.2mm x 1.118mm x 495.3mm
(13.0in x 44.0in x 19.5in)

Weight
60.8 kg (134.0 lbs)

*Peak, unweighted SPL, measured under full-space conditions at 1 meter using broadband pink noise with a 12dB crest factor and specified preset

USAGE OPTIONS



A12

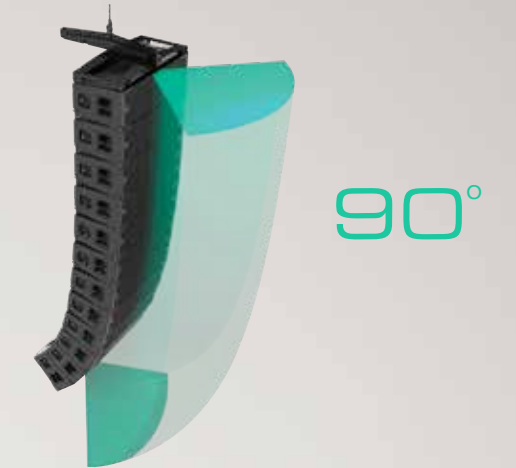

A12W



A12 & A12W

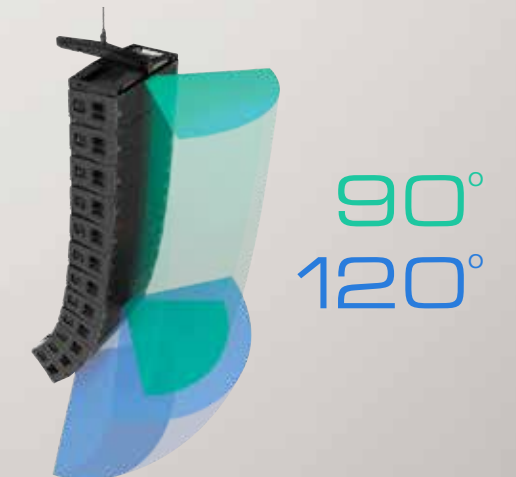

RIGGING SYSTEM

The full range of JBL VTX A-Series cabinets feature a simple to understand, patented auto-locking rigging system that streamlines your deployment while remaining highly accurate.

Four enclosures per cart are transported vertically and cabinet-to-cabinet splay angles are selected while the system is still on the ground. Then, simply suspend the speakers and the automatic Angle Lock mechanism engages and secures the cabinets to the selected position.

VERTICAL TRANSPORT CART



TRANSPORT



PREPARE



LIFT



UNLOCKED POSITION

The cabinets maintain their splay positions until pressing their release button, at which point the red locking lever opens allowing the cabinets to collapse again for storage and transportation.

AUTO-LOCKING MECHANISM

Each A12 cabinet includes two Angle Selection panels (one on each side) to set the cabinet-to-cabinet splay angle. The panels are clearly marked with a unique pin position for each angle option. Positions range from 0.25 degrees to 10 degrees and the selection can be visually identified from a distance—even when the array is suspended.



LOCKED POSITION

The RED locking lever identifies whether the system is locked or unlocked. The system is locked when the RED locking lever is recessed into the cabinet. The mechanism can be unlocked with the press of a button.

RIGGING ACCESSORIES

A comprehensive suite of suspension accessories is available for the A12 System allowing for the creation of a number of configurations. The VTX A12 AF is a lightweight Array Frame that can support the weight of up to twenty-four VTX A12 cabinets. The array frame allows for single-point, front-to-back or side-by-side suspension and the extension bar can extend the front or rear of the frame to accommodate both up- and down-tilt aiming options. The VTX A12 SB suspension bar can be used as an array frame or to implement pull-back of a VTX A12 array. When used for pull-back, the VTX A12 SB can be attached to the bottom cabinet of an array. The VTX A12 SB can also attach to the top cabinet of an array and be used as a compact array frame.

VTX A12 AF ARRAY FRAME



- Support for up to 24 x VTX A12 enclosures
- Single, front-to-back or side-by-side pick point options
- Built-in storage position for Extension Bar
- Weight: 41 kg (90 lbs)

VTX A12 AFEB ARRAY FRAME EXTENSION BAR



- Single, front-to-back or side-by-side pick point options
- 0.5-degree pick point resolution
- Includes 3 x shackles and mounting brackets
- Weight: 13.6 kg (30 lbs)

VTX A12 SB SUSPENSION BAR



- Used for suspending an array or for pull back
- Support for up to 18 x VTX A12 enclosures
- Weight: 6.4 kg (14 lbs)

VTX DELTA DELTA PLATE



- High-quality universal delta plate accessory
- Allows for up to +/- 10 degrees of horizontal adjustment
- Includes 3 x 5/8" shackles
- Support for 24 VTX cabinets
- Weight: 5.2 kg (11.5 lbs)

RIGGING EXAMPLES

VTX A12 AF Single Point

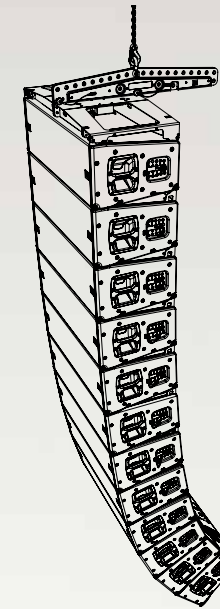

VTX A12 SB Used for Pull Back

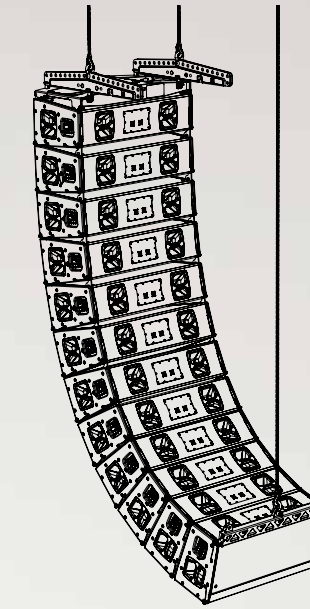

VTX A12 AF Dual Points

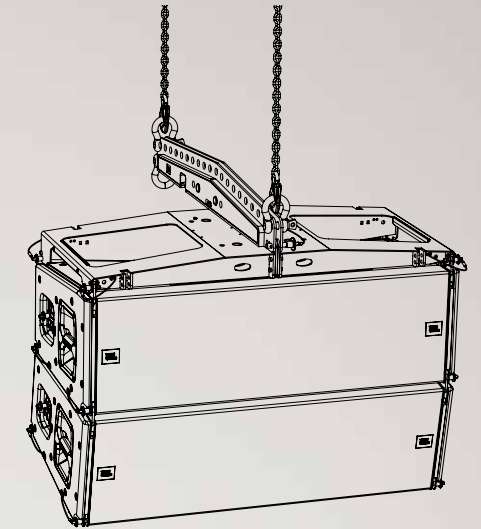

VTX A12 SB Used at the Top and Bottom of the Array

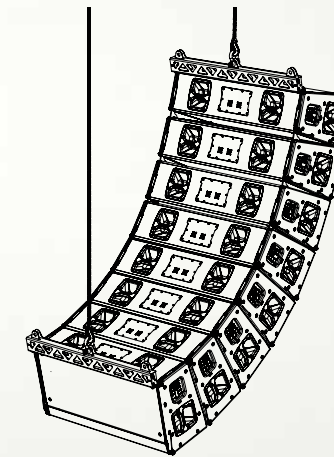

VTX A12 SB Used as Array Frame

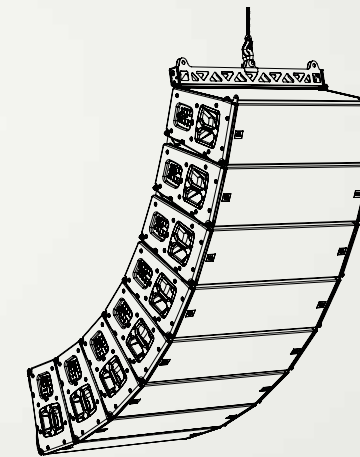

VTX A12 AF Dual Extension Bars Side-by-side Suspension Points

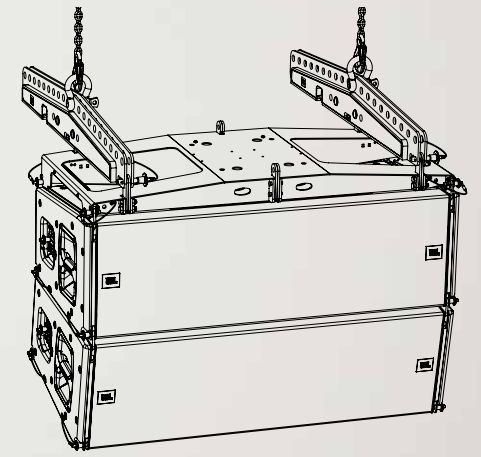

VTX A12 AF Reverse Extension Bar

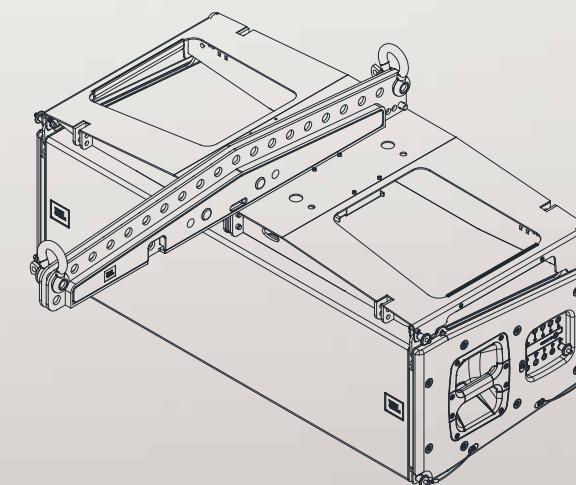

VTX DELTA

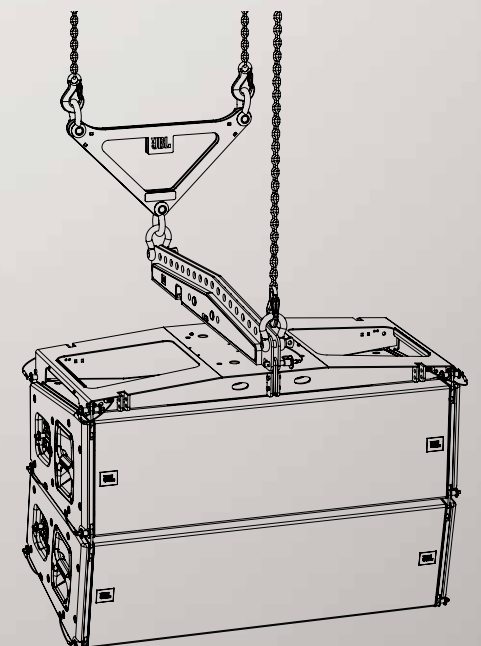

TRANSPORTATION ACCESSORIES

VTX A12 cabinets are stored and moved around on vertical transportation carts (VT) in groups of four. The VTX A12 VT is a lightweight cart solution measuring 1143mm (45") wide and 610mm (24") deep—an ideal footprint for packing in several truck sizes. An included hard-top (VT-TOP) connects to the topmost cabinet of a stack to create a robust and defined footprint that stabilizes carts during transportation. With the VT-TOP in place, other gear can be placed above the stacks for maximum truck-pack efficiency. Multiple carts can be stacked together for easy storage. A reinforced protective cover (VTX A12 VT CVR) is also available separately.

VTX A12 VT VERTICAL TRANSPORT CART



- Vertical transport cart for 4 VTX A12 enclosures
- Includes a hard top for easy stacking
- Built-in stacking features for easy storage
- Support for ground stacking
- Weight: VTX A12 VT: 29.3 kg (64.5 lbs)
VT-TOP: 13.2 kg (29 lbs)

VTX A12 VT CVR SOFT COVER



- Covers 4 x VTX A12 on a VTX A12 VT
- Includes input panel flaps for testing purposes
- Clear see-through pocket for shipping labels
- Handle cut-outs for easy transportation

TRANSPORTATION ACCESSORIES EXAMPLES

VTX A12 VT With VT-TOP

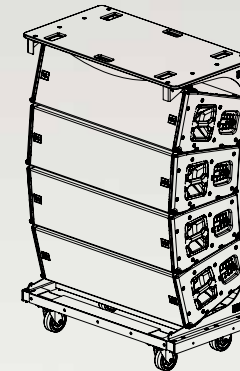

VTX A12 VT Used without the VT-TOP

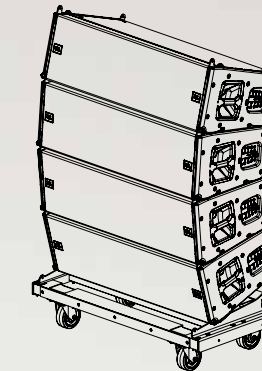

VTX A12 VT Truck packing setup

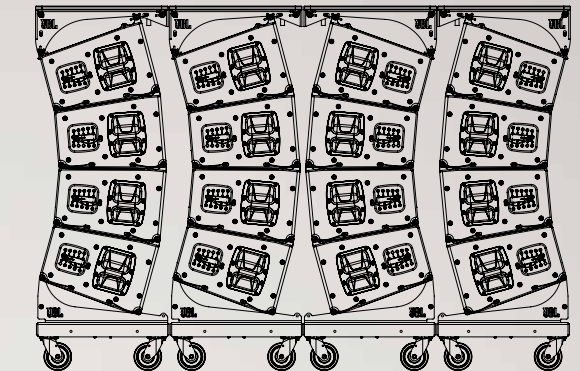

VTX A12 VT VT-TOP connected together for storage. Soft cover can be stored inbetween

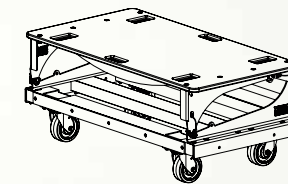

4 X VTX A12 VT Carts stacked for storage using the VT-TOPS and BOTTOMS

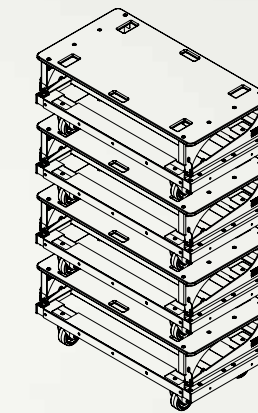

4 X VTX A12 VT Carts stacked for storage using the VT-BOTTOMS

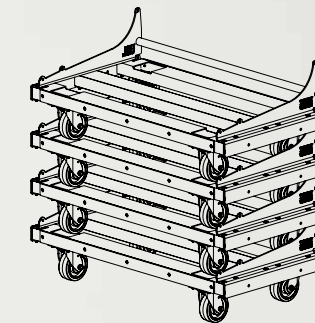

GROUND STACKING

When suspension points are not available and ground deployment is necessary, the VTX A12 VT GND outrigger system works in conjunction with the VTX A12 VT and allows the ground-stacking of A12 enclosures without removing them from the transportation cart. Screw jacks are used to lift the stack off the ground, and the innovative spring based angle-set hinges are used to adjust overall aiming.

VTX A12 VT GND GROUND STACK KIT



- Outrigger system for VTX A12 VT
- Support for 4 – 6 VTX A12 cabinets
- Screw-jacks included for adjusting height
- Compact and lightweight design
- A12s remain on the VT during setup
- Weight: 12.8 kg (28 lbs)

GROUND STACKING EXAMPLES

VTX A12 VT GND configured for down angle

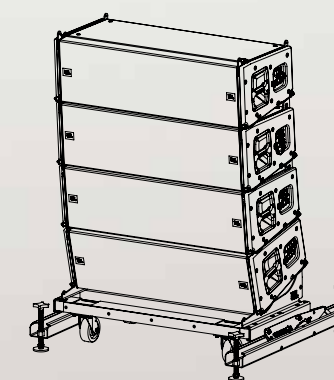

VTX A12 VT GND configured for up angle

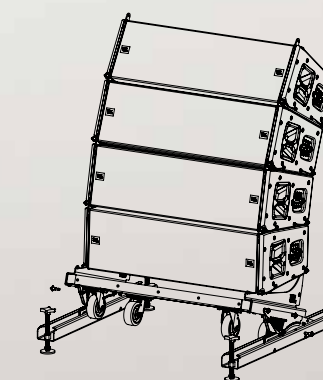

SUBWOOFERS

VTX S28

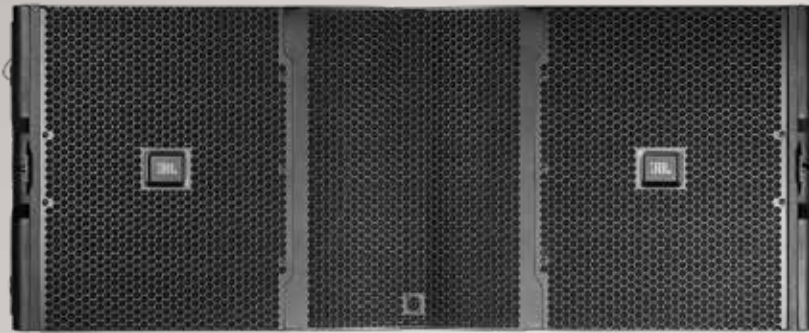

The JBL VTX S28 is a dual 18" subwoofer designed to extend the frequency response of VTX full-range systems down to 24Hz. The S28 delivers its extended low-frequency performance and extremely high peak-to-peak excursion capabilities through two 2269H 18" transducers featuring Differential Drive technology with two voice coils and two neodymium magnets. The VTX S28 can be suspended or ground-stacked and is cardioid arrayable in either configuration for improved rear rejection.

Frequency Response
24Hz – 90Hz

Coverage
Omni or Cardioid

Max SPL
140 dB

System Processing
Crown Audio I-Tech 12000HD

Nominal Impedance
2 x 8Ω

Dimensions (W x H x D)
1222mm x 493.3mm x 926.5mm
(48.1in x 19.4in x 36.5in)

Weight
83.0 kg (183 lbs)

VTX G28

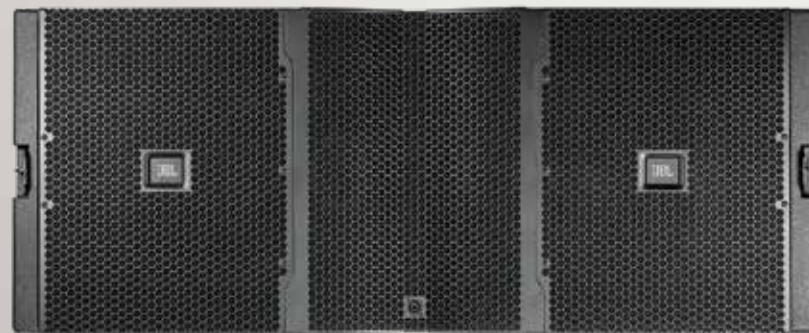

The JBL VTX G28 is a dual 18" subwoofer designed to extend the frequency response of VTX full-range systems down to 22Hz. The VTX G28 is ground stackable only and is deployable in standard or cardioid configurations for maximum rejection.

Frequency Response
24Hz – 90Hz

Coverage
Omni or Cardioid

Max SPL
140 dB

System Processing
Crown Audio I-Tech 12000HD

Nominal Impedance
2 x 8Ω

Dimensions (W x H x D)
1210.8mm x 493.3mm x 1211.1mm
(47.7in x 19.4in x 47.7in)

Weight
92.5 kg (204 lb)

SUBWOOFER ACCESSORIES

VTX V25 AFEB
Array Frame with Extension Bar

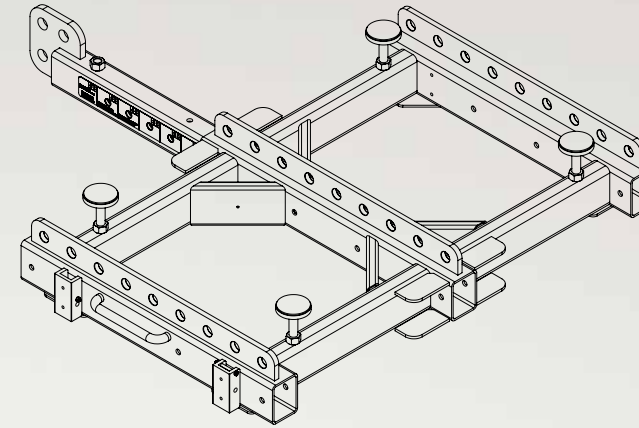

VTX V25 AFEB
Array Frame Extension Bar

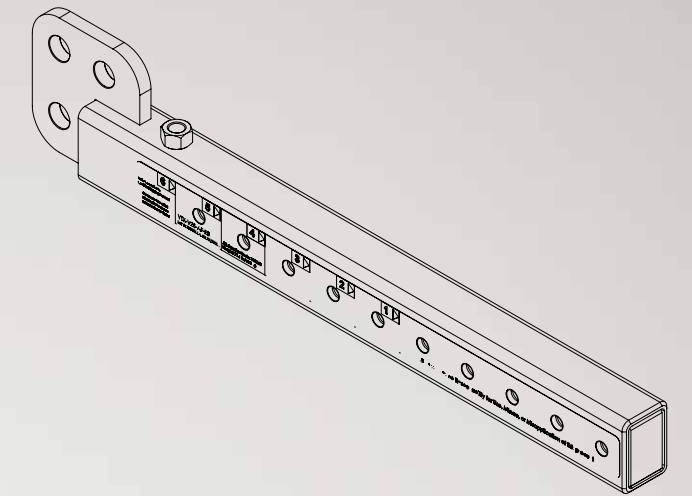

VTX-V28-VTC
Vertical Transporter

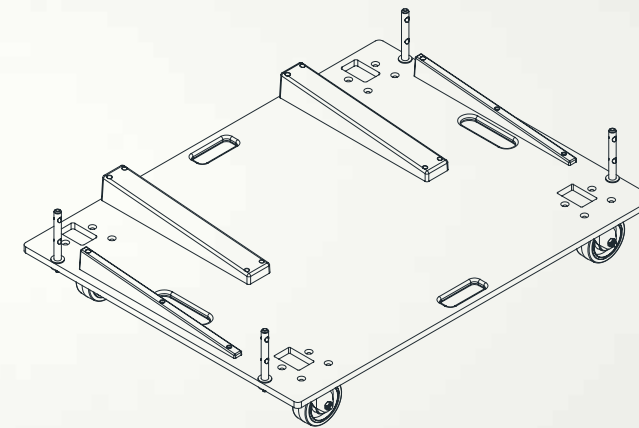

VTX-S28-ACC
Accessory Cover and Casterboard

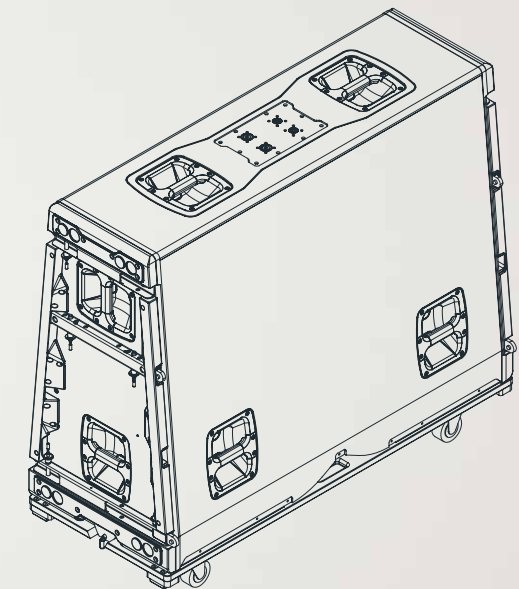

VTX-G28-ACC
Casterboard

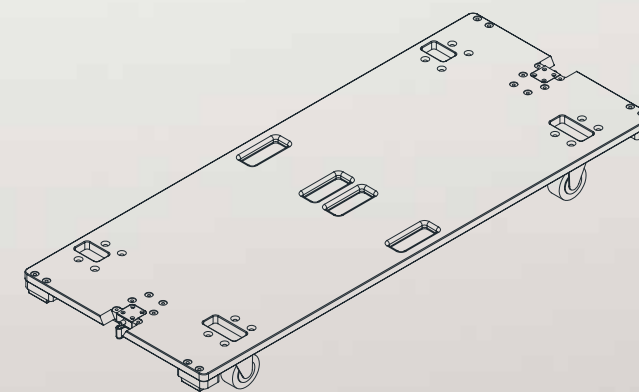

VTX-G28-ACC
Accessory Cover and Casterboard

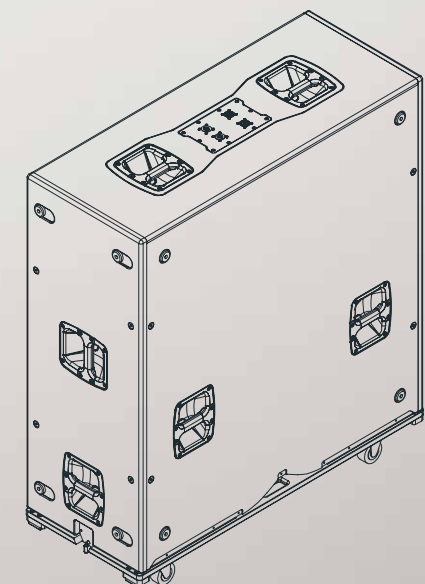

SYSTEM AMPLIFICATION

All JBL VTX-Series systems are powered worldwide, exclusively by Crown I-Tech HD amplifiers, for optimum performance and consistency.

Inside and out, the I-Tech HD is one of the most technologically advanced, professional touring amplifiers on the market today. Building on over 70 years of the innovation, invention, and insight Crown is known for the I-Tech HD features five patents—three on the power supply alone—giving you amplification that goes well beyond the expected. Available in two or four channels with a complete complement of dedicated digital signal processing on each channel, including the acclaimed LevelMAX™ Limiter Suite and optimized JBL VTX loudspeaker presets. The Crown I-Tech HD amplifiers also include a user-adjustable input section for room correction equalization and system optimizations tools such as array size compensation and circuit adjustments.

CROWN I-TECH 4X3500HD



Channels

4 inputs, 4 outputs (Analog, AES 3, VDrive, CobraNet)

Power (2.7Ω)

4 x 3800W

User EQ (Per Channel)

16 x Bands

Input Delay

4sec

Frequency Response

20Hz - 30kHz (± 0.25dB)

Sample Rate

96kHz

Dimensions (H x W x D)

8.9 cm x 48.3 cm x 43.1 cm
(3.3in x 19.0in x 16.95in)

Net Weight

29 lbs (13.2 kgs)

VRACK 4X3500HD
3X I-T 4X3500HD

CROWN I-TECH 12000HD



Channels

2 inputs, 2 outputs (Analog, AES 3, CobraNet)

Power (2.7Ω)

4 x 5400W

Signal to Noise Ratio

> 112dB

THD

< 0.1%

Frequency Response

± 0.25dB

Common Mode Rejection

> 70dB typical

Dimensions (H x W x D)

48.3 cm x 41.1 cm x 8.9 cm
(19.0in x 16.2in x 3.5in)

Net Weight

28 lbs (12.7 kgs)

VRACK 12000HD
3X I-T 12000HD

ACCURATE SETUP & CONTROL

Designing and controlling VTX systems is made possible via JBL's purpose-built control and simulation software applications. The applications feature intuitive user interfaces that are simple to understand and allow for system design in minutes. This allows for less time in front of the computer and more time with the system.



PERFORMANCE MANAGER™

JBL® Performance Manager™ is a software application designed to configure and control networked audio systems. The workflow paradigm of the Performance Manager interface guides the system designer through the complete system design, configuration and control process. A dedicated show mode provides all the monitoring and control needed to have a complete picture of how the system is performing in real time.

www.jblpro.com/performancemanager

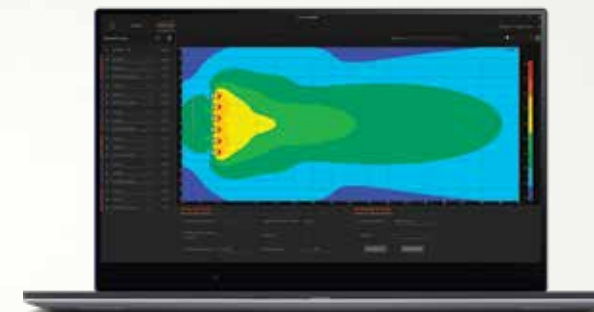

LINE ARRAY CALCULATOR 3™

LAC is a simulation software for designing and predicting JBL VTX A-Series systems. LAC predicts the acoustical performance of line array systems as well as flown and ground stacked subwoofer arrays. Subwoofer delay values can be generated for electronic delay steering (EDS) using the built-in coverage calculator. Beyond the acoustical prediction, LAC is used for mechanical validation of all used hardware and calculating weight limits and safety warnings.

www.jblpro.com/lac3



ARRAY LINK™

JBL Array Link is a mobile companion app that works in conjunction with JBL's LAC software to assist with deploying JBL VTX A-Series systems. Array Link uses a QR code system to transfer all mechanical array information from the main LAC application to a mobile phone. All relevant rigging and mechanical options are presented in an easy-to-understand layout. The application is compatible with iOS® and Android™ and can be obtained from the respective app stores.



GENERAL GUIDELINES

SUBWOOFER RATIOS

VTX A12 presets are designed for a 3:2 minimum cabinet ratio (A12 : VTX S28 or G28 subwoofers). The 3:2 ratio provides sufficient headroom for both the subwoofers and the VTX A12s to reach MAX SPL (the limiters) at the same time, while maintaining a minimum of 10dB SUB to TOP low-frequency contour. Other ratios can be used depending on the desired tonal balance target, MAX SPL and application.



VTX A12



VTX S28 VTX G28

CROWN I-TECH 4X3500HD

When using Crown Audio I-Tech 4x3500HD amplifiers, up to three VTX A12 loudspeakers can be powered per amplifier. Based on the A12 component resource requirements, this allows for optimum power-to-transducer ratio without compromising the maximum SPL capabilities of the system. Circuits of 2 cabinets can be used when higher circuiting resolution is necessary.

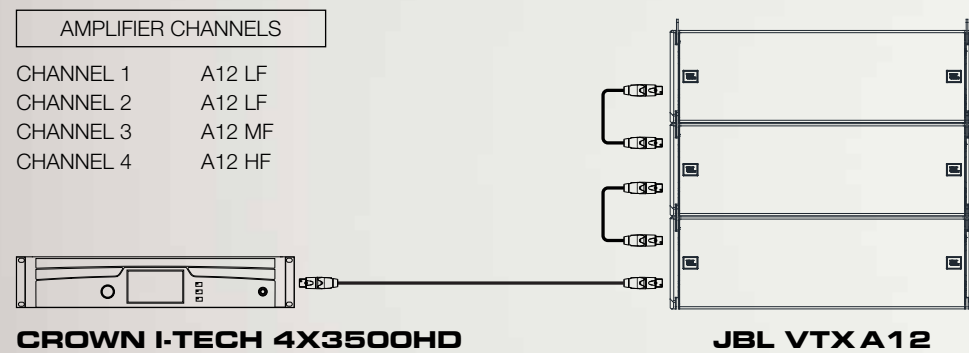

CROWN I-TECH 4X3500HD

JBL VTX A12

CROWN I-TECH 12000HD

When using Crown Audio I-Tech 12000HD amplifiers, up to three VTX A12 loudspeakers can be powered per pair of amplifiers. One Crown I-Tech 12000HD is used for powering the low-frequency section and another for the mid- and high-frequency sections. Based on the A12 component resource requirements, this allows for optimum power-to-transducer ratio without compromising the system's maximum SPL capabilities. Circuits of two cabinets can be used when higher circuiting resolution is necessary.

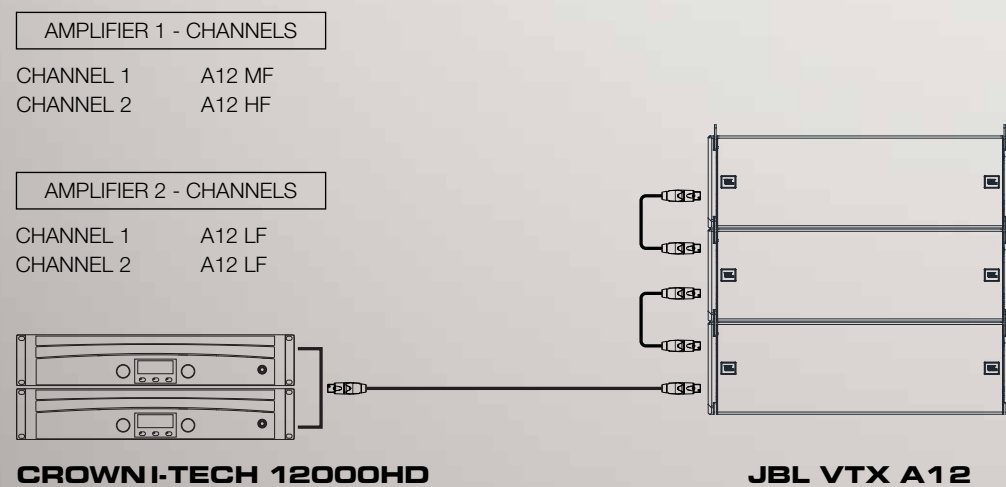

CROWN I-TECH 12000HD

JBL VTX A12

TIP: Other channel assignments can be implemented when using the 2-channel Crown Audio I-Tech HD amplifiers. Use JBL's HIQNet® Performance Manager™ control software to assign speaker presets.

CONFIGURATION EXAMPLES

PRESET EXAMPLE 1



VTX A12 OR VTX A12 80



VTX A12 OR VTX A12 80



VTX G28 60 OR VTX G28 80



VTX G28 60 OR VTX G28 80

PRESET EXAMPLE 2



VTX S28 80



VTX A12 80



VTX S28 80

VTX A12 80

VTX A12 FL 80

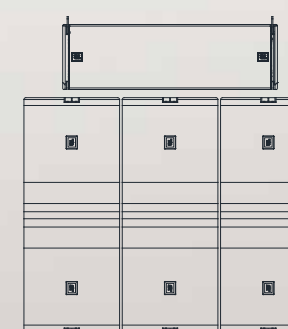

VTX G28 80

VTX A12 FL 80



VTX G28 80

VTX A12 FL 80



VTX G28 80

VTX A12 FL 80

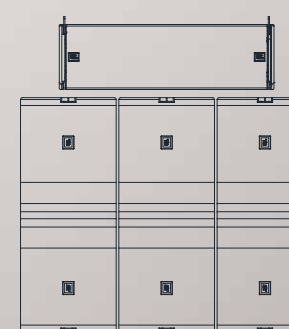

VTX G28 80

A NEW ERA IN SYSTEM INTEGRATION

PERFORMANCE | EFFICIENCY | CONTROL

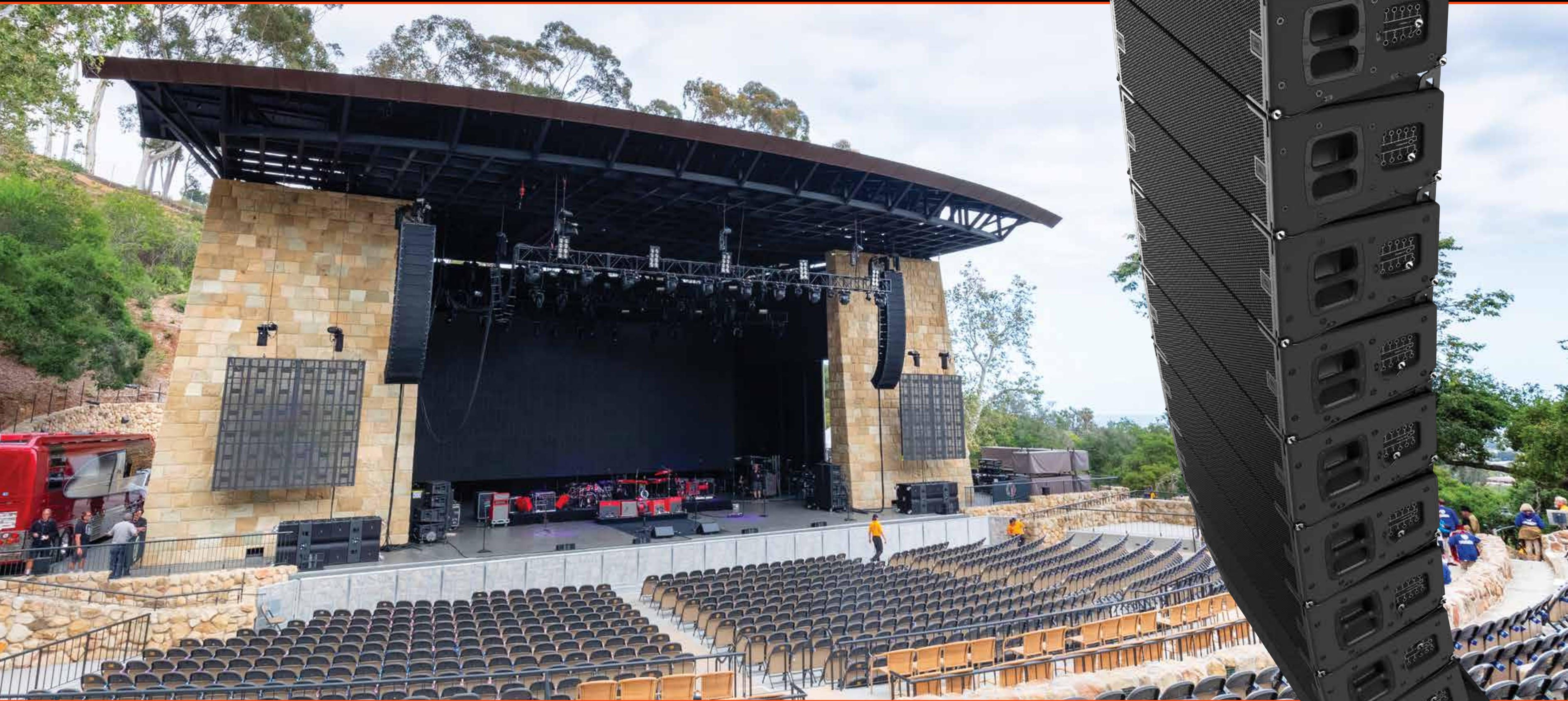

VTX:A-SERIES
SYSTEM SOLUTIONS

VTX:A-SERIES **A12**
SYSTEM SOLUTIONS

© 2018 HARMAN Professional Solutions, Incorporated
8500 Balboa Blvd, Northridge, CA 91329 USA
www.jblpro.com