



INSTRUCTION MANUAL

ENOVA DVX ALL-IN-ONE PRESENTATION SWITCHERS

DVX-3250HD-SP, DVX-3250HD-T
DVX-3255HD-SP, DVX-3255HD-T
DVX-3256HD-SP, DVX-3256HD-T
DVX-2250HD-SP, DVX-2250HD-T
DVX-2255HD-SP, DVX-2255HD-T
DVX-2210HD-SP, DVX-2210HD-T



IMPORTANT SAFETY INSTRUCTIONS

1. READ these instructions.
2. KEEP these instructions.
3. HEED all warnings.
4. FOLLOW all instructions.
5. DO NOT use this apparatus near water.
6. CLEAN ONLY with dry cloth.
7. DO NOT block any ventilation openings. Install in accordance with the manufacturer's instructions.
8. DO NOT install near any heat sources such as radiators, heat registers, stoves, or other apparatus (including amplifiers) that produce heat.
9. DO NOT defeat the safety purpose of the polarized or grounding type plug. A polarized plug has two blades with one wider than the other. A grounding type plug has two blades and a third grounding prong. The wider blade or the third prong are provided for your safety. If the provided plug does not fit into your outlet, consult an electrician for replacement of the obsolete outlet.
10. PROTECT the power cord from being walked on or pinched, particularly at plugs, convenience receptacles, and the point where they exit from the apparatus.
11. ONLY USE attachments/accessories specified by the manufacturer.



12. USE ONLY with a cart, stand, tripod, bracket, or table specified by the manufacturer, or sold with the apparatus. When a cart is used, use caution when moving the cart/apparatus combination to avoid injury from tip-over.
13. UNPLUG this apparatus during lightning storms or when unused for long periods of time.
14. REFER all servicing to qualified service personnel. Servicing is required when the apparatus has been damaged in any way, such as power-supply cord or plug is damaged, liquid has been spilled or objects have fallen into the apparatus, the apparatus has been exposed to rain or moisture, does not operate normally, or has been dropped.
15. DO NOT expose this apparatus to dripping or splashing and ensure that no objects filled with liquids, such as vases, are placed on the apparatus.
16. To completely disconnect this apparatus from the AC Mains, disconnect the power supply cord plug from the AC receptacle.
17. Where the mains plug or an appliance coupler is used as the disconnect device, the disconnect device shall remain readily operable.
18. DO NOT overload wall outlets or extension cords beyond their rated capacity as this can cause electric shock or fire.



The exclamation point, within an equilateral triangle, is intended to alert the user to the presence of important operating and maintenance (servicing) instructions in the literature accompanying the product.



The lightning flash with arrowhead symbol within an equilateral triangle is intended to alert the user to the presence of uninsulated "dangerous voltage" within the product's enclosure that may be of sufficient magnitude to constitute a risk of electrical shock to persons.



ESD Warning: The icon to the left indicates text regarding potential danger associated with the discharge of static electricity from an outside source (such as human hands) into an integrated circuit, often resulting in damage to the circuit.

- WARNING:** To reduce the risk of fire or electrical shock, do not expose this apparatus to rain or moisture.
- WARNING:** No naked flame sources - such as candles - should be placed on the product.
- WARNING:** Equipment shall be connected to a MAINS socket outlet with a protective earthing connection.
- CAUTION:** To reduce the risk of electric shock, grounding of the center pin of this plug must be maintained.

COPYRIGHT NOTICE

AMX© 2015, all rights reserved. No part of this publication may be reproduced, stored in a retrieval system, or transmitted, in any form or by any means, electronic, mechanical, photocopying, recording, or otherwise, without the prior written permission of AMX. Copyright protection claimed extends to AMX hardware and software and includes all forms and matters copyrightable material and information now allowed by statutory or judicial law or herein after granted, including without limitation, material generated from the software programs which are displayed on the screen such as icons, screen display looks, etc. Reproduction or disassembly of embodied computer programs or algorithms is expressly prohibited.

LIABILITY NOTICE

No patent liability is assumed with respect to the use of information contained herein. While every precaution has been taken in the preparation of this publication, AMX assumes no responsibility for error or omissions. No liability is assumed for damages resulting from the use of the information contained herein. Further, this publication and features described herein are subject to change without notice.

AMX WARRANTY AND RETURN POLICY

The AMX Warranty and Return Policy and related documents can be viewed/downloaded at www.amx.com.

ESD WARNING

	<p>To avoid ESD (Electrostatic Discharge) damage to sensitive components, make sure you are properly grounded before touching any internal materials.</p> <p>When working with any equipment manufactured with electronic devices, proper ESD grounding procedures must be followed to make sure people, products, and tools are as free of static charges as possible. Grounding straps, conductive smocks, and conductive work mats are specifically designed for this purpose. These items should not be manufactured locally, since they are generally composed of highly resistive conductive materials to safely drain static discharges, without increasing an electrocution risk in the event of an accident.</p> <p>Anyone performing field maintenance on AMX equipment should use an appropriate ESD field service kit complete with at least a dissipative work mat with a ground cord and a UL listed adjustable wrist strap with another ground cord</p>
---	--

	<p>WARNING: Do Not Open! Risk of Electrical Shock. Voltages in this equipment are hazardous to life. No user-serviceable parts inside. Refer all servicing to qualified service personnel.</p> <p>Place the equipment near a main power supply outlet and make sure that you can easily access the power breaker switch.</p>
---	---

WARNING: This product is intended to be operated ONLY from the voltages listed on the back panel or the recommended, or included, power supply of the product. Operation from other voltages other than those indicated may cause irreversible damage to the product and void the products warranty. The use of AC Plug Adapters is cautioned because it can allow the product to be plugged into voltages in which the product was not designed to operate. If the product is equipped with a detachable power cord, use only the type provided with your product or by your local distributor and/or retailer. If you are unsure of the correct operational voltage, please contact your local distributor and/or retailer.

FCC AND CANADA EMC COMPLIANCE INFORMATION:

This device complies with part 15 of the FCC Rules. Operation is subject to the following two conditions:

- (1) This device may not cause harmful interference, and (2) this device must accept any interference received, including interference that may cause undesired operation.

NOTE: This equipment has been tested and found to comply with the limits for a Class A digital device, pursuant to part 15 of the FCC Rules. These limits are designed to provide reasonable protection against harmful interference when the equipment is operated in a commercial environment. This equipment generates, uses, and can radiate radio frequency energy, and if it is not installed and used in accordance with the instruction manual, it may cause harmful interference to radio communications. Operation of this equipment in a residential area is likely to cause harmful interference, in which case the user will be required to correct the interference at his own expense.

CAN ICES-3 (B)/NMB-3(B)

EU COMPLIANCE INFORMATION:

Eligible to bear the CE mark; Conforms to European Union Low Voltage Directive 2006/95/EC; European Union EMC Directive 2004/108/EC; European Union Restriction of Hazardous Substances Recast (RoHS2) Directive 2011/65/EU; European Union WEEE (recast) Directive 2012/19/EU.

This product contains batteries that are covered under the 2006/66/EC European Directive, which cannot be disposed of with normal household waste. Please follow local regulations.

You may obtain a free copy of the Declaration of Conformity by visiting <http://www.amx.com/techcenter/certifications.asp>.

WEEE NOTICE:

	<p>This appliance is labeled in accordance with European Directive 2012/19/EU concerning waste of electrical and electronic equipment (WEEE). This label indicates that this product should not be disposed of with household waste. It should be deposited at an appropriate facility to enable recovery and recycling.</p>
---	--

	<p>This device is designed and evaluated under the condition of non-tropical climate; it can only be used in locations in non-tropical climate areas. Using the device in tropical climate areas could result in a potential safety hazard.</p>
---	---



This device is designed and evaluated under the condition of altitude below 2000 meters above sea level; it can only be used in locations below 2000 meters above sea level. Using the device above 2000 meters could result in a potential safety hazard.

Table of Contents

Overview	13
Common Application	13
Audio Processing	13
Integrated Control.....	14
Battery Life.....	14
Enova 325x All-in-One Presentation Switchers	15
DVX-3250HD/3255HD/3256HD.....	15
Specifications	15
Port Numbers	18
Enova 22xx All-in-One Presentation Switchers	19
DVX-2250HD/2255HD/2210HD	19
Specifications	19
Port Numbers	22
Installation	23
Overview	23
Mounting the DVX into an Equipment Rack.....	23
Ventilation.....	23
Wiring and Device Connections	24
Overview	24
Front Panel Controls and Indicators	27
LEDs	27
LCD Display	28
SWITCH Pushbutton	28
TAKE Pushbutton	28
VIDEO MENU Pushbutton	28
AUDIO MENU Pushbutton	29
Navigation Pushbuttons	29
STATUS Pushbutton	29
EXIT Pushbutton.....	30
VIDEO/AUDIO MUTE Pushbuttons.....	30
Program Port	30
USB Port.....	30
Rear Panel Audio Inputs and Outputs.....	31
AUDIO INPUTS.....	31
HDMI INPUTS.....	31
AUDIO INPUTS.....	32
MIC/LINE INPUTS.....	33
AMP OUT	33

AUDIO OUTPUTS	34
S/PDIF OUTPUT	34
Rear Panel Video Inputs and Outputs	35
MULTI/FORMAT VIDEO INPUTS.....	35
HDMI INPUTS.....	36
DXLink INPUTS.....	37
DXLINK/HDMI OUTPUTS.....	38
325x Video Outputs	38
22xx Video Outputs.....	38
Twisted Pair Cable Pinouts	39
Important Twisted Pair Cabling Requirements and Recommendations.....	39
Rear Panel Control and Power	40
Serial Ports	40
RS-232 Ports.....	40
RS-232/422/485 Ports.....	40
Relay Ports.....	41
Relay Connections	41
I/O Ports	42
IR/SERIAL Port: Connections and Wiring.....	43
AxLink Port and LED (4-pin captive-wire)	43
SDHC Card Slot	45
Configuration DIP Switch	45
Program Run Disable (PRD) Mode	45
ICSLAN Ports	45
Using the ICSLAN Network	45
DHCP Server.....	46
Opening LAN and ICSLAN Sockets from Code.....	46
USB Port.....	46
ID Pushbutton	46
Switching to Static or Dynamic IP Addressing.	46
Restoring the Controller Settings to the Factory Defaults	46
Restoring the Controller's Factory Firmware Image.....	46
LAN 10/100 Port	47
IPv4.....	47
IPv6.....	47
Power Connector/Switch/Fuse	47
Cable Details and Pinout Information	49
Overview	49
DVI-D Male to DVI-D Male Single-Link Cable.....	50
DVI-to-DVI Cable Pinout Information.....	50
DVI-A Male to 5-BNC Male Cable	51
DVI-to-5-BNC Cable Pinout Information	51
DVI-A Male to Triple RCA Male Cable	52
DVI-to-Triple RCA Cable Pinout Information	52

DVI-A Male to S-Video Male Cable	53
DVI-to-S-Video Cable Pinout Information	53
DVI-A Male to HD15 (VGA) Male Adapter	54
DVI-to-VGA Cable Pinout Information.....	54
HDMI Male to DVI-D Male Cable	55
HDMI-to-DVI-D Cable Pinout Information	55
Audio/Video Configuration	56
Overview	56
Using the Front Panel Buttons	56
Video Settings.....	56
Setting the Video Type for a Video Input	58
Changing the Video Output Resolution	58
Changing the Output Aspect Ratio	58
Selecting a Video Test Pattern	58
Audio Settings	59
Microphone Settings.....	60
Selecting an Audio Test Tone	60
Switch Menu.....	61
Status Menu	61
DVX WebConsole	62
Accessing the WebConsole	62
Master Controller Configuration Options	63
WebConsole - System Configuration.....	63
WebConsole User Interface - Additional Documentation	63
Using a Web Browser	63
Locating the IP Address of the DVX.....	64
Default User Names and Passwords.....	64
General Options	64
Video Settings	65
Video Out.....	65
Uploading an Image File.....	66
Video In.....	67
Audio Settings	68
Audio Out	68
Audio In/Microphone	70
Setting Up Surround Audio.....	71
Embedding Audio on an HDMI Output	72
Mixing Microphones onto Analog and HDMI Outputs	72
System Settings	73

NetLinx Firmware Upgrades	74
Overview	74
Before You Start	74
Verifying the Current Firmware Version	74
Downloading the Latest Firmware Files from www.amx.com	75
Downloading Enova DVX Firmware Files on www.amx.com	75
Required Order of Firmware Updates for DVX Controllers	75
Sending Firmware (*.KIT) Files to the DVX	75
Additional Documentation	77
Programming	78
Overview	78
NetLinx Channels and Levels.....	79
DVX-325xHD NetLinx Channels	79
DVX-22xHD NetLinx Channels.....	80
Channel Video Switching	81
Standby Mode	81
DVX-325xHD NetLinx Levels	82
DVX-22xHD NetLinx Levels.....	83
SEND_COMMANDS	84
Port Functionality Mapping	84
Port Numbers.....	84
AUDIO SEND_COMMANDS.....	85
AI<input>O<output>	85
?AUDIN_COMPRESSION	85
AUDIN_COMPRESSION	85
?AUDIN_COMPRESSION_ATTACK	85
AUDIN_COMPRESSION_ATTACK	85
?AUDIN_COMPRESSION_RATIO	85
AUDIN_COMPRESSION_RATIO	85
?AUDIN_COMPRESSION_RELEASE	85
AUDIN_COMPRESSION_RELEASE	86
?AUDIN_COMPRESSION_THRESH	86
AUDIN_COMPRESSION_THRESH	86
?AUDIN_DIGITAL.....	86
AUDIN_DIGITAL.....	86
?AUDIN_GAIN.....	86
AUDIN_GAIN.....	86
?AUDIN_STEREO.....	86
AUDIN_STEREO.....	87
?AUDIO_MUTE	87
AUDIO_MUTE	87
?AUDMIC_COMPRESSION.....	87
AUDMIC_COMPRESSION	87
?AUDMIC_COMPRESSION_ATTACK.....	87
AUDMIC_COMPRESSION_ATTACK	87
?AUDMIC_COMPRESSION_RATIO	87
AUDMIC_COMPRESSION_RATIO	87
?AUDMIC_COMPRESSION_RELEASE.....	87
AUDMIC_COMPRESSION_RELEASE	88
?AUDMIC_COMPRESSION_THRESH.....	88
AUDMIC_COMPRESSION_THRESH	88
AUDMIC_DUCK_ATTACK	88
AUDMIC_DUCK_HOLD.....	88

AUDMIC_DUCK_LEVEL	88
AUDMIC_DUCK_RELEASE	88
?AUDMIC_EQ_CF	89
AUDMIC_EQ_CF	89
?AUDMIC_EQ_FT	89
AUDMIC_EQ_FT	89
?AUDMIC_EQ_GAIN	89
AUDMIC_EQ_GAIN	89
?AUDMIC_EQ_Q	90
AUDMIC_EQ_Q	90
?AUDMIC_GAIN	90
AUDMIC_GAIN	90
?AUDMIC_GATING	90
AUDMIC_GATING	90
?AUDMIC_GATING_ATTACK	90
AUDMIC_GATING_ATTACK	91
?AUDMIC_GATING_DEPTH	91
AUDMIC_GATING_DEPTH	91
?AUDMIC_GATING_HOLD	91
AUDMIC_GATING_HOLD	91
?AUDMIC_GATING_RELEASE	91
AUDMIC_GATING_RELEASE	91
?AUDMIC_GATING_THRESH	91
AUDMIC_GATING_THRESH	92
?AUDMIC_LIMITER	92
AUDMIC_LIMITER	92
?AUDMIC_LIMITER_ATTACK	92
AUDMIC_LIMITER_ATTACK	92
?AUDMIC_LIMITER_RELEASE	92
AUDMIC_LIMITER_RELEASE	92
?AUDMIC_LIMITER_THRESH	92
AUDMIC_LIMITER_THRESH	93
?AUDMIC_ON	93
AUDMIC_ON	93
?AUDMIC_PHANTOM_PWR	93
AUDMIC_PHANTOM_PWR	93
?AUDMIC_PREAMP_GAIN	93
AUDMIC_PREAMP_GAIN	93
?AUDMIC_STEREO	93
AUDMIC_STEREO	94
?AUDOUT_BALANCE	94
AUDOUT_BALANCE	94
?AUDOUT_DELAY	94
AUDOUT_DELAY	94
AUDOUT_DUCK_ATTACK	94
AUDOUT_DUCK_HOLD	94
AUDOUT_DUCK_LEVEL	94
AUDOUT_DUCK_RELEASE	95
?AUDOUT_DUCK_THRESH	95
AUDOUT_DUCK_THRESH	95
?AUDOUT_DUCKING	95
AUDOUT_DUCKING	95
?AUDOUT_EQ_CF	95
AUDOUT_EQ_CF	95
?AUDOUT_EQ_FT	95
AUDOUT_EQ_FT	96
?AUDOUT_EQ_GAIN	96
AUDOUT_EQ_GAIN	96
?AUDOUT_EQ_MODE	96
AUDOUT_EQ_MODE	96
?AUDOUT_EQ_Q	96
AUDOUT_EQ_Q	97
?AUDOUT_MAXVOL	97
AUDOUT_MAXVOL	97
?AUDOUT_MINVOL	97
AUDOUT_MINVOL	97
?AUDOUT_MUTE	97
AUDOUT_MUTE	97

AUDOUT_RESET_EQ	98
?AUDOUT_STEREO	98
AUDOUT_STEREO	98
?AUDOUT_TESTTONE	98
AUDOUT_TESTTONE	98
?AUDOUT_VOLUME	98
AUDOUT_VOLUME	98
?GAIN	98
GAIN	98
?HDMIOUT_AUDIO	98
HDMIOUT_AUDIO	99
?HDMIOUT_EQ	99
HDMIOUT_EQ	99
?INPUTEQ	99
INPUTEQ	99
?PHANTOM_PWR	99
PHANTOM_PWR	99
?SPDIFOUT_AUDIO	99
SPDIFOUT_AUDIO	99
?VOLUME	99
VOLUME	99
?XPOINT	99
Video SEND_COMMANDs	100
CI<input>0<output>	100
CL<sl>I<input>0<output>	100
?INPUT	100
?OSD	100
OSD	100
XPOINT	100
?OUTPUT	101
VI<input>0<output>	101
?VIDEO_MUTE	101
VIDEO_MUTE	101
?VIDEO_TESTPATTERN	101
VIDEO_TESTPATTERN	101
?VIDIN_BRIGHTNESS	101
VIDIN_BRIGHTNESS	101
?VIDIN_BW	101
VIDIN_BW	101
?VIDIN_COLOR	101
VIDIN_COLOR	101
?VIDIN_CONTRAST	101
VIDIN_CONTRAST	102
?VIDIN_EDID	102
VIDIN_EDID	102
?VIDIN_EDID_AUTO	102
VIDIN_EDID_AUTO	102
?VIDIN_FORMAT	102
VIDIN_FORMAT	102
?VIDIN_HDCP	102
VIDIN_HDCP	103
?VIDIN_HDMI_EQ	103
VIDIN_HDMI_EQ	103
?VIDIN_HSHIFT	103
VIDIN_HSHIFT	103
?VIDIN_HUE	103
VIDIN_HUE	103
?VIDIN_NAME	104
VIDIN_NAME	104
?VIDIN_PHASE	104
VIDIN_PHASE	104
?VIDIN_PREF_EDID	104
VIDIN_PREF_EDID	104
?VIDIN_RES_AUTO	104
VIDIN_RES_AUTO	105
?VIDIN_RES_REF	105
VIDIN_RES_REF	105

?VIDIN_SATURATION	105
VIDIN_SATURATION	105
?VIDIN_STATUS	105
?VIDIN_VSHIFT	105
VIDIN_VSHIFT	105
?VIDOUT_ASPECT_RATIO	106
VIDOUT_ASPECT_RATIO	106
?VIDOUT_BLANK	106
VIDOUT_BLANK	106
?VIDOUT_BRIGHTNESS	106
VIDOUT_BRIGHTNESS	106
?VIDOUT_CONTRAST	106
VIDOUT_CONTRAST	106
?VIDOUT_FREEZE	107
VIDOUT_FREEZE	107
?VIDOUT_HSHIFT	107
VIDOUT_HSHIFT	107
?VIDOUT_HSIZE	107
VIDOUT_HSIZE	107
?VIDOUT_MUTE	107
VIDOUT_MUTE	107
?VIDOUT_ON	107
VIDOUT_ON	107
?VIDOUT_OSD	108
VIDOUT_OSD	108
?VIDOUT_OSD_COLOR	108
VIDOUT_OSD_COLOR	108
?VIDOUT_OSD_POS	108
VIDOUT_OSD_POS	108
?VIDOUT_RES	108
?VIDOUT_RES_AUTO	108
VIDOUT_RES_AUTO	108
?VIDOUT_RES_REF	108
VIDOUT_RES_REF	109
?VIDOUT_SCALE	109
VIDOUT_SCALE	109
?VIDOUT_TESTPAT	109
VIDOUT_TESTPAT	109
?VIDOUT_VSHIFT	109
VIDOUT_VSHIFT	109
?VIDOUT_VSIZE	109
VIDOUT_VSIZE	110
?VIDOUT_ZOOM	110
VIDOUT_ZOOM	110
Front Panel SEND_COMMANDS	111
?FP_LOCKOUT	111
FP_LOCKOUT	111
?FP_LOCKTYPE	111
FP_LOCKTYPE	111
?INTENSITY_LCD	111
INTENSITY_LCD	111
?INTENSITY_LEDS	111
INTENSITY_LEDS	111
System SEND_COMMANDS	112
?DXLINK_ETH	112
DXLINK_ETH	112
?DXLINK_IN_ETH	112
DXLINK_IN_ETH	112
?FAN_SPEED	112
?TEMP	112

Appendix A - Input Resolutions	113
Available Pixel Display and Refresh Rates	113
DVI, HDMI, and VGA Supported Input Resolutions	113
Composite and S-Video Supported Input Resolutions.....	114
Component Video Supported Input Resolutions.....	115
Appendix B - Output Resolutions	116
Available Pixel Display and Refresh Rates	116
DVI and HDMI Supported Output Resolutions.....	116
Appendix C - Volume Attenuation Table	117
Overview	117

Overview

Enova All-In-One Presentation Switchers combine all of the components you need to control/automate any environment into a simple, flexible, comprehensive solution including control, analog and digital audio/video inputs, audio and video switching, video scaling, local and remote distribution, plus audio mixing, and amplification - all in a single box.

FIG. 1 displays the DVX-3250HD-SP.



FIG. 1 Enova DVX-3250HD-SP

The Enova All-in-One Presentation Switchers covered in this manual include:

Enova All-in-One Presentation Switchers			
Name	FG#	Description	Page Ref
DVX-3250HD-SP	FG1906-15	10x4 All-In-One Presentation Switchers (Multi-Format, HDMI Inputs), 2x25W, 8-Ohm	page 15
DVX-3250HD-T	FG1906-17	10x4 All-In-One Presentation Switchers (Multi-Format, HDMI Inputs), 75W, 70/100V	page 15
DVX-3255HD-SP	FG1906-16	10x4 All-In-One Presentation Switchers (Multi-Format, HDMI, 2 DXLink Inputs), 2x25W, 8-Ohm	page 15
DVX-3255HD-T	FG1906-18	10x4 All-In-One Presentation Switchers (Multi-Format, HDMI, 2 DXLink Inputs), 75W, 70/100V	page 15
DVX-3256HD-SP	FG1906-22	10x4 All-In-One Presentation Switchers (Multi-Format, HDMI, 4 DXLink Inputs), 2x25W, 8-Ohm	page 15
DVX-3256HD-T	FG1906-24	10x4 All-In-One Presentation Switchers (Multi-Format, HDMI, 4 DXLink Inputs), 75W, 70/100V	page 15
DVX-2250HD-SP	FG1906-11	6x3 All-In-One Presentation Switchers (Multi-Format, HDMI Inputs), 2x25W, 8-Ohm	page 19
DVX-2250HD-T	FG1906-13	6x3 All-In-One Presentation Switchers (Multi-Format, HDMI Inputs), 75W, 70/100V	page 19
DVX-2255HD-SP	FG1906-12	6x3 All-In-One Presentation Switchers (Multi-Format, HDMI, DXLink Inputs), 2x25W, 8-Ohm	page 19
DVX-2255HD-T	FG1906-14	6x3 All-In-One Presentation Switchers (Multi-Format, HDMI, DXLink Inputs), 75W, 70/100V	page 19
DVX-2210HD-SP	FG1906-07	4x2 All-In-One Presentation Switchers (Multi-Format, HDMI Inputs), 2x25W, 8-Ohm	page 19
DVX-2210HD-T	FG1906-09	4x2 All-In-One Presentation Switchers (Multi-Format, HDMI Inputs), 75W, 70/100V	page 19

Common Application

Enova DVX All-in-One Presentation Switchers are ideal solutions when used to simplify A/V control and distribution in sophisticated presentation environments and conference rooms, including those supporting audio and video conferencing. It also fits well in classrooms and auditoriums that need multiple displays, or video previewing.

Audio Processing

Enova DVX All-in-One Presentation Switchers feature built-in audio mixing and amplification that outputs two channels at 25 Watts each into 8-ohms after passing through a mixer and an integrated equalizer to accommodate the size, furnishings, surfaces, and functional requirements in every room. There are also three stereo line level outputs each with its own mixing and equalization settings.

Integrated Control

The 325x-series DVX includes the equivalent of an NX-3200 central controller. The 22xx-series DVX includes the equivalent of an NX-2200 central controller. All DVX models also include a front control panel for an added level of convenience. The DVX features standard RS-232, IR, digital I/O, and relay control ports for control over environment and third-party equipment.

Battery Life

Enova 325x- and 22xx-series All-in-One Presentation Switchers use a combination lithium battery and clock crystal package. The battery is a commonly available CR2032 lithium battery. The battery has an average shelf life of 10 years. In normal use, the time will be shorter than the average shelf life depending on the amount of time the unit has no external power for the clock circuit. Typical useful life of the battery is 8 years under the specified temperature range. (see *Operating Environment* in the Specifications table for each type of DVX in next two chapters for more information.)

Enova 325x All-in-One Presentation Switchers

DVX-3250HD/3255HD/3256HD

FIG. 2 displays the DVX-3250HD-SP.



FIG. 2 Enova DVX-3250HD-SP

Specifications

The following table lists the specifications for the Enova 325x All-in-One Presentation Switchers:

DVX-3250HD/3255HD/3256HD Specifications	
Power:	~100-240V, 50/60Hz
Power Consumption:	<ul style="list-style-type: none"> • 90 Watts typical without amplifier • 95 to 100 Watts typical average with amplifier • 30 Watts typical in low-power mode
Memory:	<ul style="list-style-type: none"> • 256 MB SDRAM • 1 MB Non-volatile RAM (NVRAM) • 4 GB Flash
Amplifier:	<ul style="list-style-type: none"> • 2 x 25W into 8 Ohms Class D stereo amplifier (capable of driving loads in the range of 2-8 ohms) (-SP models only) • 70V or 100V at 75W amplified variable mono audio (-T models only)
Integrated Controller:	Equivalent of an NX-3200 central controller on-board
Front Panel Components:	
Program Port:	1 Type-B USB port that can connect to a USB port on a PC and access the NetLinX Studio program for controller configuration.
USB Port:	1 Type-A USB port for connecting a mass storage device for loading .tkn files, reading or writing configuration files and log files, or updating the firmware on the unit.
LEDs:	<ul style="list-style-type: none"> • LINK/ACT (green) - Link/Activity LED lights when the Ethernet cables are connected and terminated correctly and blinks when receiving Ethernet data packets. • STATUS (green) - Status LED blinks to indicate that the system is programmed and communicating properly. • INPUT (yellow) - Input LED blinks to indicate that the Controller is receiving data. • OUTPUT (red) - Output LED blinks to indicate that the Controller is transmitting data. • ICSLAN (red) - ICSLAN LED blinks when the category cable to port 1 is connected and terminated correctly. The LED also blinks when receiving LAN data packets. • SERIAL (red/yellow) - 8 sets of LEDs indicate that RS-232 ports (2-4, 6-8) and RS-232/422/485 Ports (1, 5) are transmitting or receiving data. • RELAYS (red) - 8 LEDs indicate relay channels 1-8 are active (closed) on Port 21. • IR/SERIAL (red) - 8 LEDs indicate that IR/Serial channels 1-8 are transmitting control data on Port 11-18. • I/O (yellow) - 8 LEDs indicate that I/O channels 1-8 are active on Port 22.
LCD display:	Liquid crystal display (2 lines with 20 characters per line) indicates current volume level and displays the Video, Audio, and Status menus. See the <i>LCD Display</i> section on page 28 for details.
SWITCH pushbutton:	Press to access the Switch menu on the LCD display. Use the menu to choose to switch audio, video or both from any input to any output.
TAKE pushbutton:	While in the Switch menu, press to implement an audio/video switch.
VIDEO MENU pushbutton:	Press to access the Video menu on the LCD display. There are two video menus (VIDEO OUTPUT and VIDEO INPUT) and both are accessible by using this button. Multiple presses cycle through the various VIDEO menus.

DVX-3250HD/3255HD/3256HD Specifications (Cont.)	
AUDIO MENU pushbutton:	Press to access the Audio menu on the LCD display. There are three audio menus (AUDIO OUTPUT, AUDIO INPUT, and MIC) and all are accessible by using this button. Multiple presses cycle through the various AUDIO menus.
Navigational pushbuttons:	4 directional buttons for navigating the options in the Switch, Video, Audio, and Status menus (on the LCD display).
STATUS pushbutton:	Press to access the STATUS menu on the LCD display on which you can view system status and other system information.
EXIT pushbutton:	Press to exit the current menu and return to the default menu page, Main Amp Output/Volume.
VIDEO MUTE pushbutton:	Press to mute/un-mute (enable/disable) all video output displays. Video Mute results in a blank screen on the output displays.
AUDIO MUTE pushbutton:	Press to mute/un-mute all audio outputs.
Rear Panel Components:	
RS-232 (Ports 2-4, 6-8):	6 5-pin RS-232 control ports using 5-pin 3.5 mm mini-Phoenix (male) connectors with XON/XOFF (transmit on/transmit off), CTS/RTS (clear to send/ready to send). Supports 300-115,200 baud.
RS-232/422/485 (Ports 1 and 5):	2 10-pin RS-232/422/485 control ports using a 10-pin 3.5 mm mini-Phoenix (male) connector with XON/XOFF (transmit on/transmit off), CTS/RTS (clear to send/ready to send). Supports 300-115,200 baud.
Relays (Port 21):	8-channel single-pole single-throw relay port Each relay is independently controlled. Supports up to 8 independent external relay devices Channel range = 1-8 Each relay can switch up to 24 V _{DC} or 28 V _{AC} @ 1 A Two 8-pin 3.5 mm mini-Phoenix (male) connectors provide connection to relays
Digital I/O (Port 22):	8-channel binary I/O port for contact closure with each input being capable of voltage sensing. Input format is software selectable with interactive power sensing for IR ports.
IR/Serial (Ports 11-18):	8 IR/Serial control ports support high-frequency carriers of up to 1.142 MHz with each output being capable of two electrical formats: IR or Serial. 8 IR/Serial data signals can be generated simultaneously. IR ports support data mode (at limited baud rates and wiring distances).
SDHC Slot:	1 SDHC card slot for future use.
Configuration DIP Switch:	The Configuration DIP Switch allows you to set boot-time operations (see the <i>Configuration DIP Switch</i> section on page 45 for more information.)
ICSLAN Ports:	1 RJ-45 connector for ICSLAN interface
USB Port:	1 Type-A USB port for connecting a mass storage device for loading .tkn files, reading or writing configuration files and log files, or updating the firmware on the unit.
ID Pushbutton:	1 black ID pushbutton used during boot to revert to factory configuration or factory firmware. Also used after boot to toggle IP mode between Static and DHCP.
LAN Port:	RJ-45 connector provides TCP/IP communication. See the <i>LAN 10/100 Port</i> section on page 47 for more information.
AUDIO INPUTS:	8 analog audio inputs: <ul style="list-style-type: none"> • 4 female 1/8" stereo mini-phono jacks receive up to four unbalanced line-level audio inputs. (There are only 2 jacks available on the DVX-3256HD.) See the <i>AUDIO INPUTS</i> section on page 31 for more information. • 4 3.5mm 5-pin captive-wire connector provides for fixed or variable, balanced or unbalanced line-level audio inputs. See the <i>AUDIO INPUTS</i> section on page 32 for more information.
MIC/LINE INPUTS:	2 3.5mm 3-pin captive-wire connectors receive up to 2 mono microphones (balanced or unbalanced audio and switchable Phantom Power). See the <i>MIC/LINE INPUTS</i> section on page 33 for more information.
AMP OUT:	<ul style="list-style-type: none"> • 1 5mm 4-position captive wire connector provides amplified audio output with volume control (-SP models only). • Two 2-position captive wire connectors provide 70V or 100V mono amplified audio output (-T models only). See the <i>AMP OUT</i> section on page 33 for more information.
AUDIO OUTPUTS:	3 3.5mm 5-pin captive-wire connector provides for balanced or unbalanced, mono or stereo line-level audio output. See the <i>AUDIO OUTPUTS</i> section on page 34 for more information.
S/PDIF OUTPUT:	1 Coaxial RCA connector provides digital S/PDIF audio output that can mirror any of the 4 analog audio outputs or the 4 HDMI outputs.

DVX-3250HD/3255HD/3256HD Specifications (Cont.)	
Rear Panel Components: (Cont.)	
MULTI FORMAT VIDEO INPUTS:	4 DVI-I input connectors provide analog and digital video inputs for up to four video sources. (There are only 2 DVI-I connectors on the DVX-3256HD.) Each MULTI FORMAT VIDEO INPUT connector supports VGA, S-Video, composite video, component video, DVI, or HDMI video input. See the <i>Available Pixel Display and Refresh Rates</i> section on page 113 for information on supported video formats and resolutions. See the <i>Cable Details and Pinout Information</i> section on page 49 for information about wiring conversion cables.
HDMI INPUTS:	<ul style="list-style-type: none"> • 6 HDMI inputs (5-10) receive digital audio and video from up to six video sources. (DVX-3250HD only) • 4 HDMI inputs (5-8) receive digital audio and video from up to four video sources. (DVX-3255HD only) • 4 HDMI inputs (3-6) receive digital audio and video from up to four video sources. (DVX-3256HD only) All HDMI inputs are HDCP 1.4 compatible. See the <i>HDMI INPUTS</i> section on page 36 for more information.
DXLINK INPUTS:	<ul style="list-style-type: none"> • 2 RJ-45 inputs (9-10) provide support for digital video, audio, Ethernet, bi-directional control and power over Category Cable from any DXLink transmitter. (DVX-3255HD only). • 4 RJ-45 inputs (7-10) for video, audio, Ethernet, and bi-directional control of DXLink devices and power over Category Cable from any DXLink transmitter (DVX-3256HD only) See the <i>Supported Video Settings</i> section on page 37 for more information.
VIDEO OUTPUTS:	<ul style="list-style-type: none"> • 4 HDMI Output connectors (1-4) each provide HDMI digital audio and video output. • 2 DXLink outputs (1, 3) mirror HDMI outputs 1 and 3. See the <i>DXLINK/HDMI OUTPUTS</i> section on page 38 for more information and important cable recommendations.
AxLink Port:	2 4-pin 3.5 mm mini-Phoenix (male) connectors that provides data and power to external AxLink control devices. Green AxLink LED indicates the state of the AxLink port. See the <i>AxLink Port and LED (4-pin captive-wire)</i> section on page 43 for more information.
Power Connector:	IEC Power cord connector: ~100-240V AC, 47-63Hz
Operating Environment:	<ul style="list-style-type: none"> • Storage temperature: -10° C to 70° C (14° F to 158° F) • Operating Temperature: 0° C to 40° C (32° F to 104° F) • Operating Relative Humidity: 5% to 85% non-condensing
Supported Video Resolutions:	HD resolutions up to 1080p and RGB resolutions up to 1920x1200@60Hz. Higher resolutions are supported in pass-through mode. See the <i>Available Pixel Display and Refresh Rates</i> section on page 113 for a complete listing of all supported video resolutions.
Dimensions (HWD):	5 3/16" x 17" x 14" (13.2 cm x 43.2 cm x 35.6 cm)
Weight:	18.2 lb (8.26 kg)
Enclosure:	Metal with black matte finish
Certifications:	<ul style="list-style-type: none"> • FCC Part 15 Class A • IC CISPR 22 Class A • C-Tick CISPR 22 Class A • CE EN 55022 Class A and EN 55024 • LVD EN 60950-1 • IEC 60950-1 • cULus UL 60950-1
Included Accessories:	<ul style="list-style-type: none"> • 1 Power Cord, Universal • 2 Connector, Phoenix2, M, TH, R/A, BLACK, 5.08mm • 7 Connector, Phoenix5, F, BLACK • 2 Connector, Phoenix3, F, BLACK • 1 Commoning Strip, Cypher, 8 Pos., 3.5 mm, Phoenix Connector • 1 Connector, Phoenix4, F, TH, BLACK, 3.5mm • 2 Connector, Phoenix, 8-pin, FEM, BLACK • 1 Connector, Phoenix, 10-pin, FEM, BLACK • 2 Front Rack Mounting Brackets • 8 Screw, #8-32 x .375, PFH, Undercut, BLACK • 2 CC-NIRC, IR Emitter with 3.5mm Phoenix Connector (FG10-000-11) • 1 CC-DVIM-VGAF, DVI to HD-15 Female Adapter (FG10-2170-13)

DVX-3250HD/3255HD/3256HD Specifications (Cont.)

Optional Accessories:	<ul style="list-style-type: none"> • CC-DVI-5BNM DVI to 5 BNC adapter cable (FG10-2170-08) • CC-DVI-RCA3M DVI to 3 Male RCA adapter cable for component and composite connections (FG10-2170-09) • CC-DVI-SVID DVI to S-Video adapter cable (FG10-2170-10) • CC-DVIM-VGAF DVI to HD15 female adapter cable (FG10-2170-13) • CC-3.5ST5-RCA2F 2 RCA Female to 5-Pin Phoenix Cable (FG10-003-20) • AVB-RX-DXLINK-HDMI DXLink™ HDMI Receiver Module (FG1010-500) • AVB-TX-HDMI-DXLINK DXLink HDMI Transmitter Module (FG1010-300) • AVB-TX-MULTI-DXLINK DXLink Multi-Format Transmitters (FG1010-310) • AVB-WP-TX-MULTI-DXLINK DXLink Multi-Format Wallplate Transmitters (FG1010-320-BL/WH)
-----------------------	--

Port Numbers

The following table lists the port numbers for the DVX-325xHD:

DVX-325xHD Port Numbers				
RS-232	RS-232/422/485	IR/Serial	I/O	Relay
2-4, 6-8	1, 5	11-18	22	21

Enova 22xx All-in-One Presentation Switchers

DVX-2250HD/2255HD/2210HD

FIG. 3 displays the DVX-2250HD-SP.



FIG. 3 Enova DVX-2250HD-SP

Specifications

The following table lists the specifications for the Enova 22xx All-in-One Presentation Switchers:

DVX-2250HD/2255HD/2210HD Specifications	
Power:	~100-240V, 50/60Hz
Power Consumption:	<ul style="list-style-type: none"> 80 Watts typical without amplifier 85 to 90 Watts typical average with amplifier 30 Watts typical in low-power mode
Memory:	<ul style="list-style-type: none"> 256 MB SDRAM 1 MB Non-volatile RAM (NVRAM) 4 GB Flash
Amplifier:	<ul style="list-style-type: none"> 2 x 25W into 8 Ohms Class D stereo amplifier (capable of driving loads in the range of 2-8 ohms) (-SP models only) 70V or 100V at 75W amplified variable mono audio (-T models only)
Integrated Controller:	Equivalent of an NX-2200 central controller on-board
Front Panel Components:	
Program Port:	1 Type-B USB port that can connect to a USB port on a PC and access the NetLinX Studio program for controller configuration.
USB Port:	1 Type-A USB port for connecting a mass storage device for loading .tkn files, reading or writing configuration files and log files, or updating the firmware on the unit.
LEDs:	<ul style="list-style-type: none"> LINK/ACT (green) - Link/Activity LED lights when the Ethernet cables are connected and terminated correctly and blinks when receiving Ethernet data packets. STATUS (green) - Status LED blinks to indicate that the system is programmed and communicating properly. INPUT (yellow) - Input LED blinks to indicate that the Controller is receiving data. OUTPUT (red) - Output LED blinks to indicate that the Controller is transmitting data. ICSLAN (red) - ICSLAN LED blinks when the category cable to port 1 is connected and terminated correctly. The LED also blinks when receiving LAN data packets. SERIAL (red/yellow) - 4 sets of LEDs indicate that the RS-232 ports (2-4) and RS-232/422/485 port (1) are transmitting or receiving data. RELAYS (red) - 4 LEDs indicate relay channels 1-4 are active (closed) on Port 21. IR/SERIAL (red) - 4 LEDs indicate that IR/Serial channels 1-4 are transmitting control data on Ports 11-14. I/O (yellow) - 4 LEDs indicate that I/O channels 1-4 are active on Port 22
LCD display:	Liquid crystal display (2 lines with 20 characters per line) indicates current volume level and displays the Video, Audio, and Status menus. See the <i>LCD Display</i> section on page 28 for details.
SWITCH pushbutton:	Press to access the Switch menu on the LCD display. Use the menu to choose to switch audio, video or both from any input to any output.
TAKE pushbutton:	While in the Switch menu, press to implement an audio/video switch.
VIDEO MENU pushbutton:	Press to access the Video menu on the LCD display. There are two video menus (VIDEO OUTPUT and VIDEO INPUT) and both are accessible by using this button. Multiple presses cycle through the various VIDEO menus.

DVX-2250HD/2255HD/2210HD Specifications (Cont.)	
AUDIO MENU pushbutton:	Press to access the Audio menu on the LCD display. There are three audio menus (AUDIO OUTPUT, AUDIO INPUT, and MIC) and all are accessible by using this button. Multiple presses cycle through the various AUDIO menus.
Navigational pushbuttons:	4 directional buttons for navigating the options in the Switch, Video, Audio, and Status menus (on the LCD display).
STATUS pushbutton:	Press to access the STATUS menu on the LCD display on which you can view system status and other system information.
EXIT pushbutton:	Press to exit the current menu and return to the default menu page, Main Amp Output/Volume.
VIDEO MUTE pushbutton:	Press to mute/un-mute (enable/disable) all video output displays. Video Mute results in a blank screen on the output displays.
AUDIO MUTE pushbutton:	Press to mute/un-mute all audio outputs.
Rear Panel Components:	
RS-232/422/485 (Port 1):	1 10-pin RS-232/422/485 control ports using a 10-pin 3.5 mm mini-Phoenix (male) connector with XON/XOFF (transmit on/transmit off), CTS/RTS (clear to send/ready to send). Supports 300-115,200 baud.
RS-232 (Ports 2-4):	3 5-pin RS-232 control ports using 5-pin 3.5 mm mini-Phoenix (male) connectors with XON/XOFF (transmit on/transmit off), CTS/RTS (clear to send/ready to send). Supports 300-115,200 baud.
Relay (Port 21):	4 2-pin 4-channel single-pole single-throw relay ports. Each relay is independently controlled. Supports up to 4 independent external relay devices Channel range = 1-4 Each relay can switch up to 24 V _{DC} or 28 V _{AC} @ 1 A 8-pin 3.5 mm mini-Phoenix (male) connector provides connection to relays
Digital I/O (Port 22):	4-channel binary I/O port for contact closure with each input being capable of voltage sensing. Input format is software selectable with interactive power sensing for IR ports.
IR/Serial (Ports 11-14):	4 IR/Serial control ports support high-frequency carriers of up to 1.142 MHz with each output being capable of two electrical formats: IR or Serial. 4 IR/Serial data signals can be generated simultaneously. IR ports support data mode (at limited baud rates and wiring distances).
AxLink Port:	4-pin 3.5 mm mini-Phoenix (male) connector that provides data and power to external AxLink control devices. Green AxLink LED indicates the state of the AxLink port.
Configuration DIP Switch:	The Configuration DIP Switch allows you to set boot-time operations (see <i>Configuration DIP Switch</i> section on page 45 for more information.)
ICSLAN:	1 RJ-45 connector for ICSLAN interface.
USB Port:	1 Type-A USB port for connecting a mass storage device for loading .tkn files, reading or writing configuration files and log files, or updating the firmware on the unit.
ID Pushbutton:	1 black ID pushbutton used during boot to revert to factory configuration or factory firmware. Also used after boot to toggle IP mode between Static and DHCP.
LAN Port:	RJ-45 connector provides TCP/IP communication. See the <i>LAN 10/100 Port</i> section on page 47 for more information.
AUDIO INPUTS:	8 analog audio inputs: <ul style="list-style-type: none"> • 2 female 1/8" stereo mini-phono jacks receive up to two unbalanced line-level audio inputs. See the <i>AUDIO INPUTS</i> section on page 31 for more information. • 2 3.5mm 5-pin captive-wire connector provides for fixed or variable, balanced or unbalanced line-level audio inputs. See the <i>AUDIO INPUTS</i> section on page 32 for more information.
MIC/LINE INPUTS:	2 3.5mm 3-pin captive-wire connectors receive up to 2 mono microphones (balanced or unbalanced audio and switchable Phantom Power). See the <i>MIC/LINE INPUTS</i> section on page 33 for more information.
AMP OUT:	<ul style="list-style-type: none"> • AMP: 4-position captive wire connector provides amplified audio output with volume control (-SP models only). • AMP: Two 2-position captive wire connectors provide 70V or 100V mono amplified audio output (-T models only). See the <i>AMP OUT</i> section on page 33 for more information.
AUDIO OUTPUTS:	2 3.5mm 5-pin captive-wire connector provides for balanced or unbalanced, mono or stereo line-level audio output. See the <i>AUDIO OUTPUTS</i> section on page 34 for more information.
S/PDIF OUTPUT:	1 Coaxial RCA connector provides digital S/PDIF audio output that can mirror any of the 3 analog audio outputs, 2 HDMI outputs, or DXLink output.

DVX-2250HD/2255HD/2210HD Specifications (Cont.)	
Rear Panel Components: (Cont.)	
MULTI FORMAT VIDEO INPUTS:	2 DVI-I input connectors provide analog and digital video inputs for up to two video sources. Each MULTI FORMAT VIDEO INPUT connector supports VGA, S-Video, composite video, component video, DVI, or HDMI video input. See the <i>Available Pixel Display and Refresh Rates</i> section on page 113 for information on supported video formats and resolutions. See the <i>Cable Details and Pinout Information</i> section on page 49 for information about wiring conversion cables.
HDMI INPUTS:	<ul style="list-style-type: none"> • 4 HDMI inputs (3-6) receive digital audio and video from up to four video sources. (DVX-2250HD only) • 2 HDMI inputs (3-4) receive digital audio and video from up to two video sources. (DVX-2255HD and DVX-2210HD only) All HDMI inputs are HDCP 1.4 compatible. See the <i>HDMI INPUTS</i> section on page 36 for more information.
DXLINK INPUTS:	2 RJ-45 inputs (5-6) provide support for digital video, audio, Ethernet, bi-directional control and power over Category Cable from any DXLink transmitter (DVX-2255HD only). See the <i>Supported Video Settings</i> section on page 37 for more information.
VIDEO OUTPUTS:	<ul style="list-style-type: none"> • 2 HDMI Output connectors (1-2) each provide HDMI digital audio and video output. • 1 DXLink RJ-45 output (3) provides digital video, audio, Ethernet, and bi-directional control over Twisted Pair Cable to DXLink Receivers. (On the DVX-2210HD, the DXLink output mirrors HDMI port 1.) See the <i>DXLINK/HDMI OUTPUTS</i> section on page 38 for more information and important cable recommendations.
Power Connector:	IEC Power cord connector: ~100-240V AC, 47-63Hz
Operating Environment:	<ul style="list-style-type: none"> • Storage temperature: -10° C to 70° C (14° F to 158° F) • Operating Temperature: 0° C to 40° C (32° F to 104° F) • Operating Relative Humidity: 5% to 85% non-condensing
Supported Video Resolutions:	HD resolutions up to 1080p and RGB resolutions up to 1920x1200@60Hz. Higher resolutions are supported in pass-through mode. See the <i>Available Pixel Display and Refresh Rates</i> section on page 113 for a complete listing of all supported video resolutions.
Dimensions (HWD):	5 3/16" x 17" x 14" (13.2 cm x 43.2 cm x 35.6 cm)
Weight:	<ul style="list-style-type: none"> • DVX-2250HD/DVX-2255HD: 18.3 lbs (8.31 kg) • DVX-2210HD-SP: 17 lbs (7.7 kg) • DVX-2210HD-T: 21 lbs (9.5 kg)
Enclosure:	Metal with black matte finish
Certifications:	<ul style="list-style-type: none"> • FCC Part 15 Class A • IC CISPR 22 Class A • C-Tick CISPR 22 Class A • CE EN 55022 Class A and EN 55024 • LVD EN 60950-1 • IEC 60950-1 • cULus UL 60950-1
Included Accessories:	<ul style="list-style-type: none"> • 1 Power Cord, Universal • 2 Connector, Phoenix2, M, TH, R/A, BLACK, 5.08mm • 7 Connector, Phoenix5, F, BLACK • 2 Connector, Phoenix3, F, BLACK • 1 Commoning Strip, Cypher, 8 Pos., 3.5 mm, Phoenix Connector • 1 Connector, Phoenix4, F, TH, BLACK, 3.5mm • 2 Connector, Phoenix, 8-pin, FEM, BLACK • 1 Connector, Phoenix, 10-pin, FEM, BLACK • 2 Front Rack Mounting Brackets • 8 Screw, #8-32 x .375, PFH, Undercut, BLACK • 2 CC-NIRC, IR Emitter with 3.5mm Phoenix Connector (FG10-000-11) • 1 CC-DVIM-VGAF, DVI to HD-15 Female Adapter (FG10-2170-13)
Optional Accessories:	<ul style="list-style-type: none"> • CC-DVI-5BNM DVI to 5 BNC adapter cable (FG10-2170-08) • CC-DVI-RCA3M DVI to 3 Male RCA adapter cable for component and composite connections (FG10-2170-09) • CC-DVI-SVID DVI to S-Video adapter cable (FG10-2170-10) • CC-DVIM-VGAF DVI to HD15 female adapter cable (FG10-2170-13) • CC-3.5ST5-RCA2F 2 RCA Female to 5-Pin Phoenix Cable (FG10-003-20) • AVB-RX-DXLINK-HDMI DXLink™ HDMI Receiver Module (FG1010-500) • AVB-TX-HDMI-DXLINK DXLink HDMI Transmitter Module (FG1010-300) • AVB-TX-MULTI-DXLINK DXLink Multi-Format Transmitters (FG1010-310) • AVB-WP-TX-MULTI-DXLINK DXLink Multi-Format Wallplate Transmitters (FG1010-320-BL/WH)

Port Numbers

The following table lists the port numbers for the DVX-22xxHD:

DVX-22xxHD Port Numbers				
RS-232	RS-232/422/485	IR/Serial	I/O	Relay
2-4	1	11-14	22	21

Installation

Overview

This chapter provides information on installing a DVX into an equipment rack.

Mounting the DVX into an Equipment Rack

The DVX occupies three rack units in a standard equipment rack. The following steps apply to mounting the DVX.

1. Discharge any static electricity from your body by touching a grounded metal object.
2. Position and install the mounting brackets, as shown in FIG. 4, using the supplied mounting screws.

NOTE: *The left and right mounting brackets are not identical. Please install in the orientation shown.*

FIG. 4 displays how the brackets should be attached to the DVX:

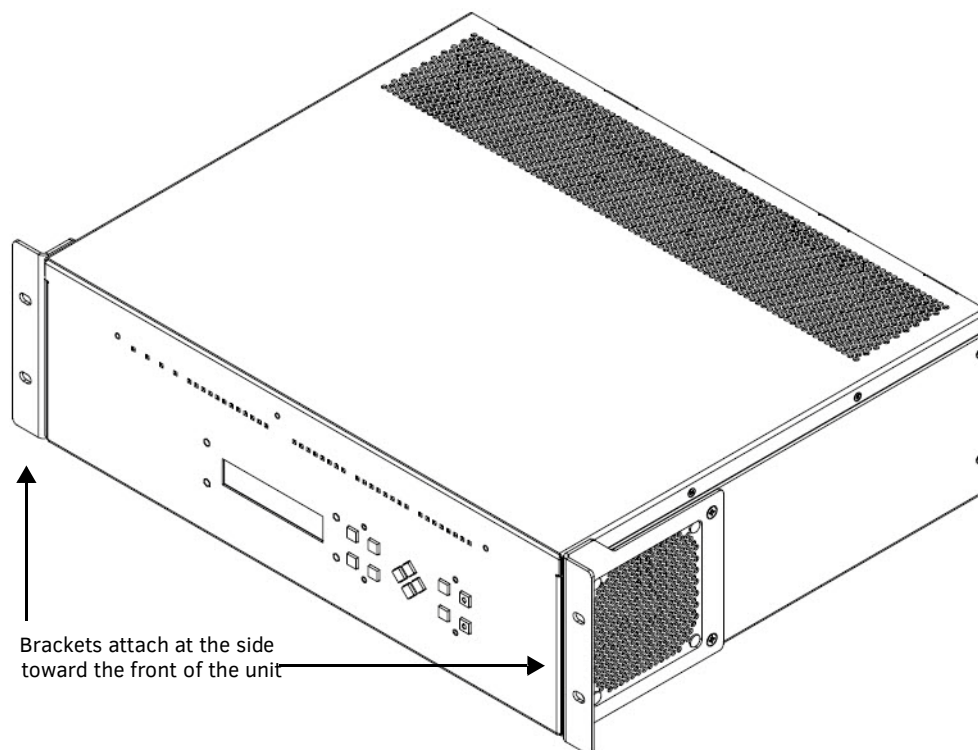

FIG. 4 Rack mounting the DVX

3. Install the DVX in the mounting rack by using the mounting screws to affix the unit to the rack.
4. Connect any applicable wires to the DVX. Refer to the *Wiring and Device Connections* section on page 24 for wiring diagrams and pinout descriptions.

CAUTION: *DO NOT stand other units directly on top of the DVX when it is rack mounted, as this will place excessive strain on the mounting brackets.*

Ventilation

ALWAYS ensure that the rack enclosure is adequately ventilated. Do not block any ventilation openings. Sufficient airflow must be achieved (by convection or forced-air cooling) to satisfy the ventilation requirements of all the items of equipment installed within the rack.

NOTE: *The maximum operating ambient temperature is 40°C (104°F).*

CAUTION: *When installing equipment into a rack, distribute the units evenly. Otherwise, hazardous conditions may be created by an uneven weight distribution.*

Reliable earthing (grounding) of rack-mounted equipment should be maintained.

The DVX should not be installed in enclosed spaces. It is recommended that you leave 1 RU of space above the DVX when you install it in a rack.

Wiring and Device Connections

Overview

This chapter provides functional details for each item on the front and rear panel of the DVX. Wiring specifications are also provided, when applicable.

FIG. 5 displays the front panel of the DVX-3250HD, DVX-3255HD, and DVX-3256HD.

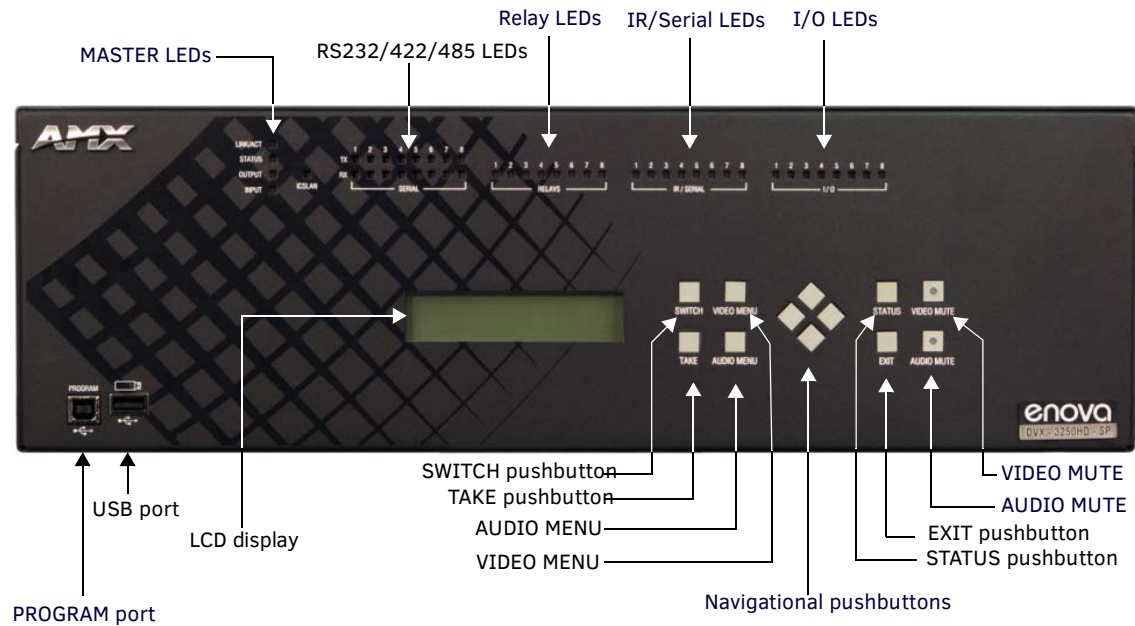

FIG. 5 DVX-3250HD-SP front panel

FIG. 6 displays the rear panel of the DVX-3250HD-SP:

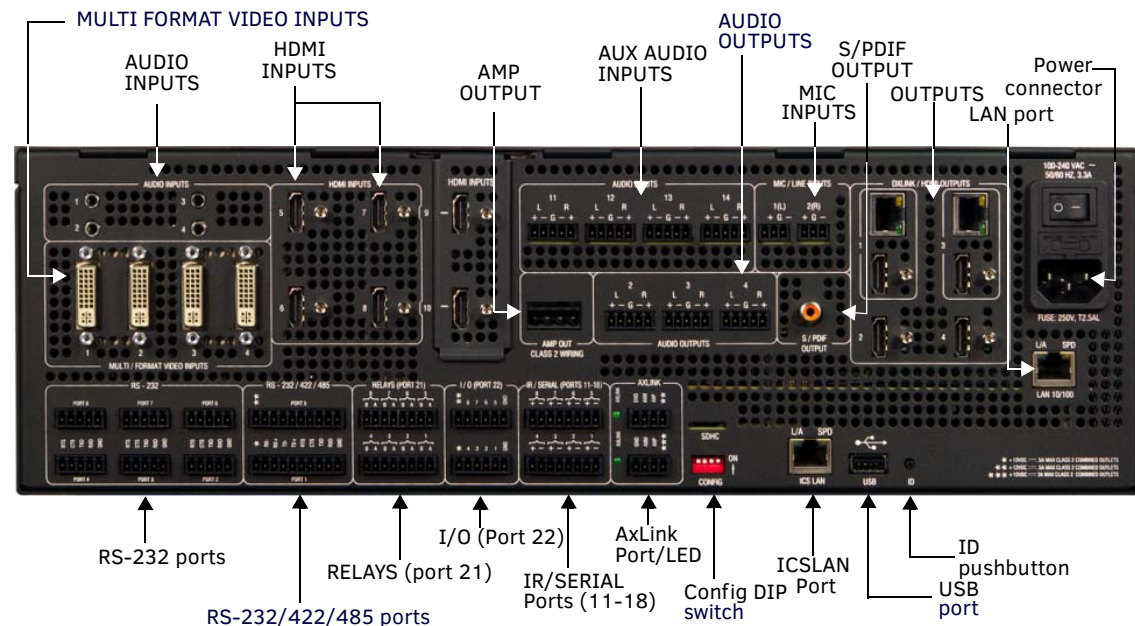

FIG. 6 DVX-3250HD-SP rear panel

The DVX-3255HD-SP features the same options on the rear panel as the DVX-3250HD-SP with the exception that two DXLink inputs appear in place of two of the HDMI inputs.

FIG. 7 displays the rear panel of the DVX-3255HD-T.

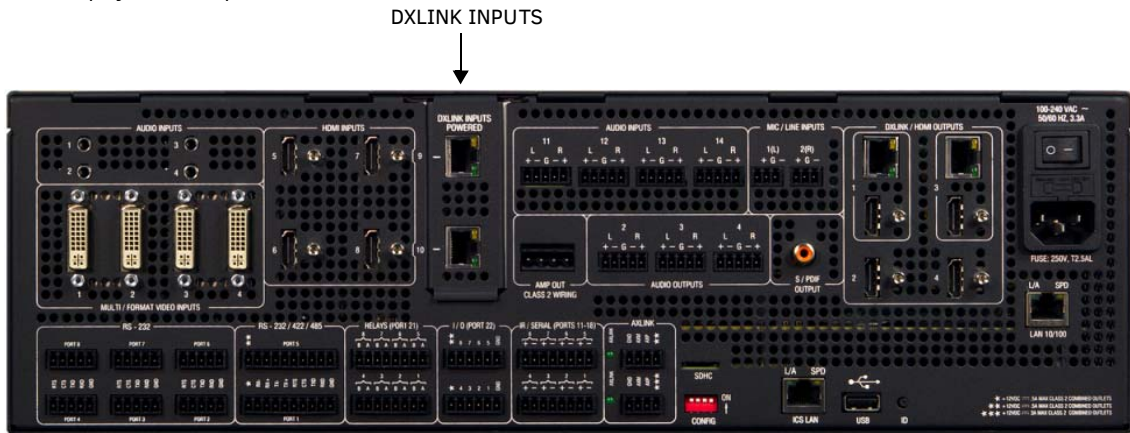

FIG. 7 DVX-3255HD-SP rear panel

The DVX-3256HD-SP features the same options on the rear panel as the DVX-3255HD-SP with the exception that two HDMI inputs appear in place of two 1/8" mini-audio jacks and two DVI inputs on ports 3 and 4 and two DXLink inputs appear in place of two HDMI inputs on ports 7 and 8.

FIG. 8 displays the rear panel of the DVX-3256HD-SP.

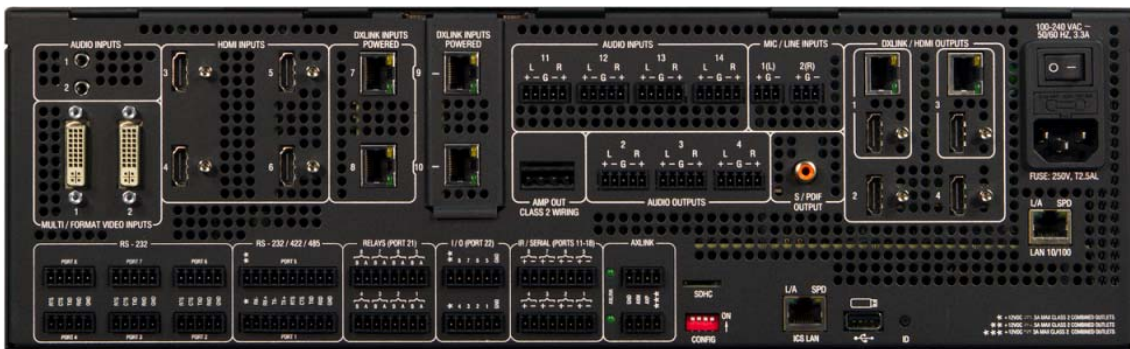

FIG. 8 DVX-3256HD-SP rear panel

FIG. 9 displays the front panel of the DVX-2250HD-SP and DVX-2255HD-SP:

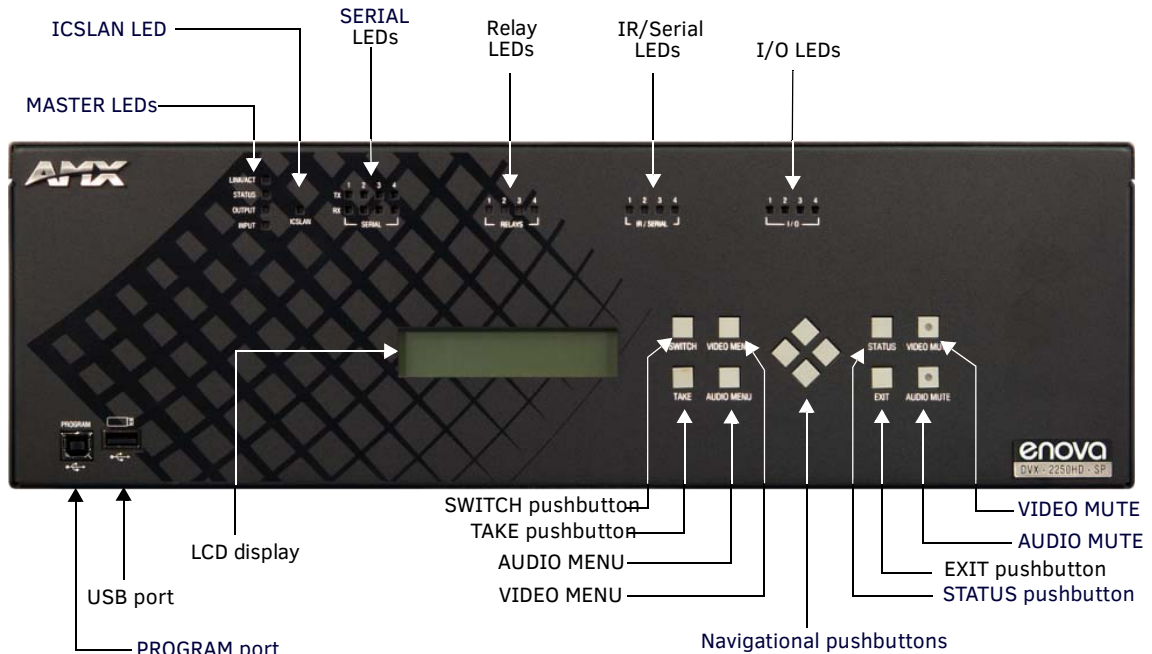

FIG. 9 DVX-2250HD-SP front panel

FIG. 10 displays the rear panel of the DVX-2250HD-SP.

The DVX-2255HD-SP features the same options on the rear panel as the DVX-2250HD-SP with the exception that two DXLink inputs appear in place of two of the HDMI inputs.

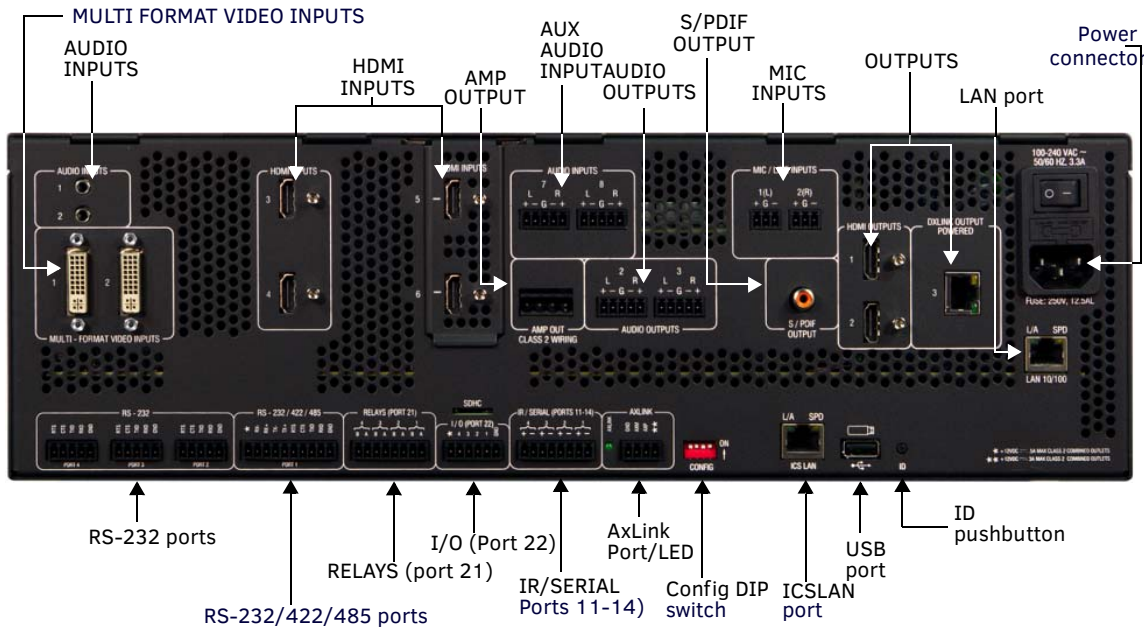

FIG. 10 DVX-2250HD-SP rear panel

FIG. 11 displays the rear panel of the DVX-2255HD-SP:

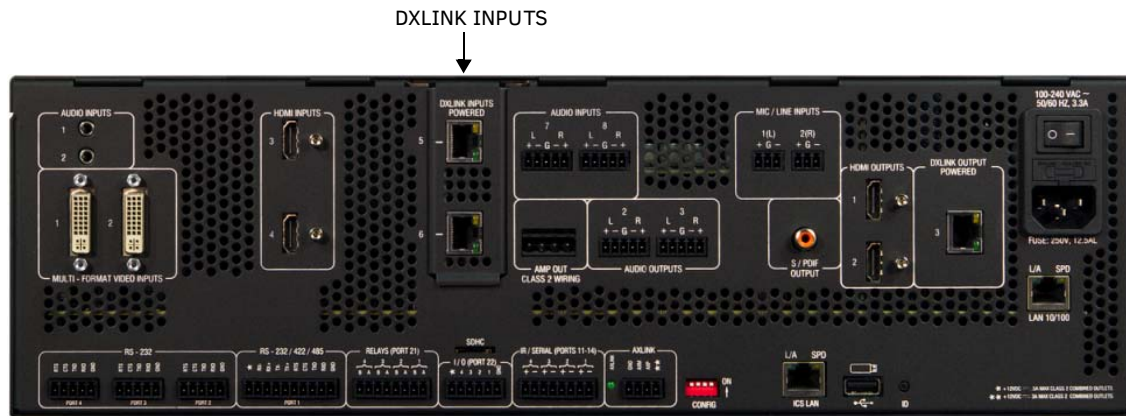

FIG. 11 DVX-2255HD-SP rear panel

FIG. 12 displays the rear panel of the DVX-2210HD-SP:



FIG. 12 DVX-2210HD-SP rear panel

Front Panel Controls and Indicators

The following sub-sections describe each component on the front panel of the DVX. Refer to FIG. 5 on page 24 for the component layout of the front panel.

LEDs

The LEDs on the front panel indicate the communications status of several different connections, as described in the table below: FIG. 13 displays the front panel LEDs for the 325x All-in-One Presentation Switchers:

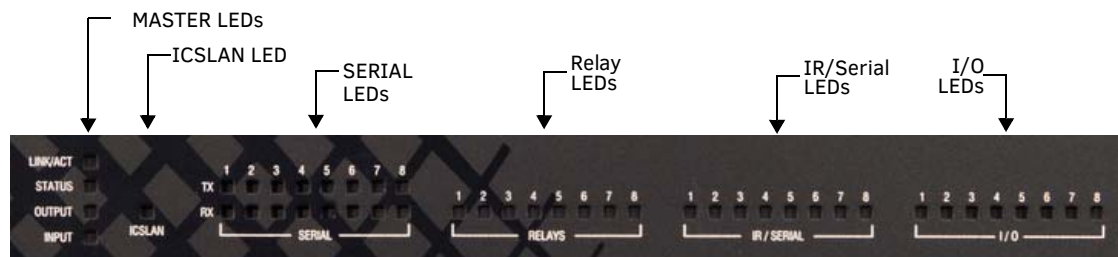

FIG. 13 Front Panel - LEDs (325x models)

FIG. 13 displays the front panel LEDs for the 22xx All-in-One Presentation Switchers:

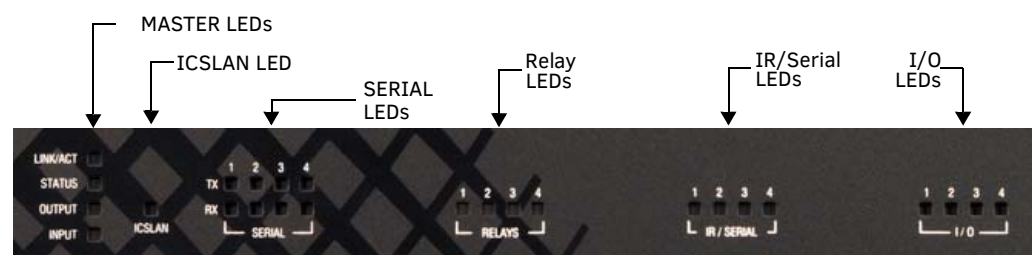

FIG. 14 Front Panel - LEDs (22xx models)

Front Panel LEDs		
Label	Color	Description
LINK/ACT	green	Blinks when receiving LAN data packets.
STATUS	green	Blinks to indicate that the system is programmed and communicating properly.
INPUT	yellow	Blinks to indicate that the Controller is receiving data.
OUTPUT	red	Blinks to indicate that the Controller is transmitting data.
ICSLAN	red	Blinks when the category cable to port 1 is connected and terminated correctly. The LED also blinks when receiving LAN data packets.
SERIAL (1-8)	red/yellow	8 sets of LEDs indicate that the RS-232 ports (2-4, 6-8) and RS-232/422/485 ports (1, 5) are transmitting or receiving data. Red = transmitting data Yellow = receiving data
RELAYS (1-8)	red	Lights to indicate that one or more of the relay channels (1-8) of port 21 are currently active (closed).
IR/SERIAL (1-8)	red	Lights to indicate that one or more of the IR/Serial channels (1-8) of ports 11-18 are currently transmitting control data.
I/O (1-8)	yellow	Lights to indicate that one or more of the I/O channels (1-8) of port 22 are currently active.

NOTE: DVX models 22xx feature only 4 SERIAL, RELAYS, IR/SERIAL, or I/O LEDs each.

LCD Display

During normal operation, the 2 x 20 line LCD display indicates output volume information. The LCD backlight on the display turns off after 35 seconds of inactivity.

FIG. 15 displays the front panel LCD display.



FIG. 15 LCD display

The LCD Display also displays VIDEO menus (Video Output and Video Input), AUDIO menus (Audio Output, Audio Input, and Mic Input), SWITCH menu, and STATUS menu selections (see the *Audio/Video Configuration* section on page 56 for more information), and indicates current status of any adjustments made to settings within these menus.

SWITCH Pushbutton

Press the SWITCH pushbutton to access the SWITCH menu on the LCD display. Press this button to switch the audio, video, or both from any input to any output. Press the TAKE pushbutton to implement the switch.

FIG. 16 displays the SWITCH pushbutton.



FIG. 16 SWITCH Pushbutton

TAKE Pushbutton

Press the TAKE pushbutton to implement an audio/video switch while you are in the Switch menu on the LCD display. When in an audio or video menu, press the button to cycle through audio and video inputs or outputs (depending on the menu.) This button does not access the menus or change the currently selected menu.

FIG. 17 displays the TAKE pushbutton.



FIG. 17 TAKE Pushbutton

VIDEO MENU Pushbutton

Press the VIDEO MENU pushbutton to access the video options, displayed on the LCD display. There are two video menus (VIDEO OUTPUT and VIDEO INPUT) and both are accessible by using this button. Multiple presses cycle through the various VIDEO menus.

FIG. 18 displays the VIDEO MENU pushbutton.



FIG. 18 VIDEO MENU Pushbutton

The Video menu enables you to see and adjust most parameters of the video input and output signals.

- Use the UP and DOWN navigational buttons to traverse the various configuration parameters.
- Use the LEFT and RIGHT navigational buttons to adjust the selected video parameter.

Adjustments take effect immediately (some parameter changes may exhibit a slight delay) and are saved when you advance to another option or exit the menu. The menu exits automatically after no user interaction on the front panel for 30 seconds.

See the *Video Settings* section on page 56 for a listing of all available options and instructions on how to change the settings.

AUDIO MENU Pushbutton

Press the AUDIO MENU pushbutton to access the audio options, displayed on the LCD display. There are three audio menus (AUDIO OUTPUT, AUDIO INPUT, and MIC) and all are accessible by using this button. Multiple presses cycle through the various AUDIO menus.

FIG. 19 displays the AUDIO MENU pushbutton.



FIG. 19 AUDIO MENU Pushbutton

The Audio menu enables you to see and adjust most parameters of the audio input and output signals.

- Use the UP and DOWN navigational buttons to traverse the various parameters.
- Use the LEFT and RIGHT navigational buttons to adjust the selected audio parameter.

Adjustments take effect immediately and are saved when you advance to another option or exit the menu. The menu exits automatically after no user interaction on the front panel for 30 seconds.

See the *Audio Settings* section on page 59 for a listing of all available options and instructions on how to change the settings.

Navigation Pushbuttons

The four directional navigation buttons (Left/Right/Up/Down) enable you to navigate through and adjust the configurable parameters shown on the LCD display. The UP and DOWN navigation buttons are used to move between configurable parameters within a menu. Pressing UP takes you to the previous configuration parameter. Pressing DOWN takes you to the next configuration parameter. These buttons do not change the currently selected menu.

The LEFT and RIGHT navigation buttons are used to change the setting of the displayed parameter. If the parameter is read-only the value cannot change. Pressing LEFT decreases the value displayed if the setting is numeric, or goes to the previously set item if the setting is a set selection. Pressing RIGHT increases the value displayed if the setting is numeric, or goes to the next set item if the setting is a set selection. These buttons do not change the currently selected menu.

FIG. 20 displays the navigation pushbuttons.

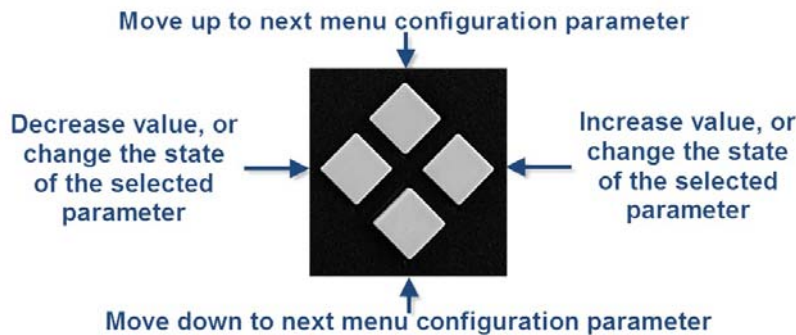

FIG. 20 Navigation Pushbuttons

STATUS Pushbutton

Press the STATUS pushbutton to access the STATUS menu on the LCD display.

FIG. 21 displays the STATUS pushbutton.



FIG. 21 STATUS Pushbutton

The STATUS menu enables you to see status information such as IP address and installed firmware versions as well as adjust LCD and LED backlight intensity.

- Use the UP and DOWN navigational buttons to traverse the various options.
- Use the LEFT and RIGHT navigational buttons to adjust the selected LCD and LED backlight intensity (when selected).

Adjustments take effect immediately and are saved when you advance to another option or exit the menu. The menu exits automatically after no user interaction on the front panel for 30 seconds.

See the *Status Menu* section on page 61 for a listing of all available options and instructions on how to change the settings.

EXIT Pushbutton

Press the EXIT pushbutton to exit any menu on the LCD display.

FIG. 22 displays the EXIT pushbutton.



FIG. 22 EXIT Pushbutton

VIDEO/AUDIO MUTE Pushbuttons

- Press the VIDEO MUTE button to enable or disable video on all output displays.
- Press the AUDIO MUTE button to enable or disable audio for all audio outputs.

FIG. 23 displays the VIDEO/AUDIO MUTE pushbuttons.

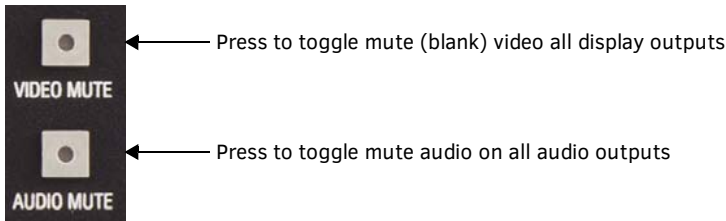

FIG. 23 VIDEO/AUDIO MUTE Pushbuttons

The pushbuttons light (red) to indicate that Video and/or Audio muting is active.

Program Port

The front panel of all models features one Type-B USB port for connecting the controller to a PC via USB cable.

The Program port uses a standard Type-A-to-Type-B USB cable to connect to a PC. When connected, you can view your DVX among the listed Masters connected via USB in NetLinx Studio. See the Initial Configuration chapter in the *NX-Series Controllers WebConsole and Programming Guide* for more information.



FIG. 24 Program port

USB Port

The front panel of all models features one Type-A USB port you can use to connect a mass storage device for loading .tkn files, reading or writing configuration files and log files, or updating the firmware on the unit.

NOTE: *This USB port only supports a FAT32 file system.*

This USB port (FIG. 25) uses standard USB cabling to connect to any mass storage or peripheral devices.



FIG. 25 USB port

NOTE: *USB hubs are not supported on this port.*

Rear Panel Audio Inputs and Outputs

The following sub-sections describe each component on the rear panel of the DVX. Refer to FIG. 6 on page 24 for the component layout of the rear panel.

AUDIO INPUTS

The AUDIO INPUTS connectors are female 1/8" stereo mini-phono jacks that receive up to four unbalanced audio inputs. These connectors feature the following specifications:

- Nominal input level: +4 dBu (1.228 Vrms) or -10 dBu (0.3262 Vrms) unbalanced
- Maximum input level: 2 Vrms
- Input impedance: >12k ohms unbalanced, >12k ohms balanced, DC coupled

FIG. 26 displays the AUDIO INPUTS connectors.



FIG. 26 AUDIO INPUTS connectors

The following table lists the number of ports and the port numbers for each model of DVX.

AUDIO INPUTS Ports		
DVX Model	No. of Ports	Port Numbers
DVX-3250HD/3255HD	4	1-4
DVX-3256HD	2	1-2
DVX-2250HD/2255HD/2210HD	2	1-2

HDMI INPUTS

The HDMI INPUT connectors on the rear panel routes digital audio (and video) from connected source input devices to the connected output devices. These inputs support the following audio formats:

Supported Audio Formats		
SA-CD	Dolby Digital Plus	DST (as used in SA-CD)
DVD-Audio	MPEG1-layerI*	DSD (as used in SA-CD)
DTS-HD Master Audio™	MPEG1-layerII	DTS
Dolby TrueHD	MP3*	ATRAC*
LPCM	MPEG2*	WMA Pro*
Dolby Digital (AC-3)	AAC LC*	MLP (as used in DVD-Audio)
* - Not available as a compressed format, but supported when output as LPCM.		

For more information about these connectors, including wiring, see the *HDMI INPUTS* section on page 36.

Some DVX models have DXLink input ports, which support embedded audio, in place of HDMI input ports. See the *Supported Video Settings* section on page 37 for more information.

The following table lists the number of digital audio ports and the port numbers for each model of DVX.

Digital Audio Ports				
DVX Model	No. of HDMI Ports	Port Numbers	No. of DXLink Ports	Port Numbers
DVX-3250HD	6	5-10	0	N/A
DVX-3255HD	4	5-8	2	9-10
DVX-3256HD	4	3-6	4	7-10
DVX-2250HD	4	5-8	0	N/A
DVX-2255HD	2	3-4	2	5-6
DVX-2210HD	2	3-4	0	N/A

AUDIO INPUTS

The AUDIO INPUTS connectors are 3.5 mm 5-position captive-wire terminals that can be wired for either balanced (differential) or unbalanced (single-ended) stereo audio. Since the DVX allows independent switching of video and audio, video and audio inputs of the same number do not have to be connected to the same source equipment. These connectors feature the following specifications:

- Nominal input level: +4 dBu (1.228 Vrms) balanced or -10 dBu (0.3262 Vrms) unbalanced
- Maximum input level: 2 Vrms
- Input impedance: >12k ohms unbalanced, >12k ohms balanced, DC coupled

FIG. 27 displays the AUDIO INPUTS connectors.

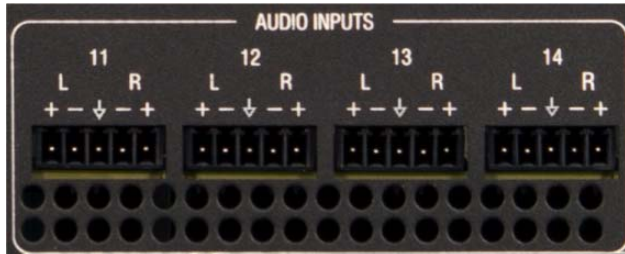

FIG. 27 AUDIO INPUTS connectors

The following table lists the number of ports and the port numbers for each model of DVX.

AUDIO INPUTS Ports		
DVX Model	No. of Ports	Port Numbers
DVX-3250HD/3255HD/3256HD	4	11-14
DVX-2250HD/2255HD/2210HD	2	7-8

Source devices require either balanced (differential) or unbalanced (single-ended) connections. FIG. 28 illustrates options for wiring between sources and input connectors. More than one option can be used in the same system.

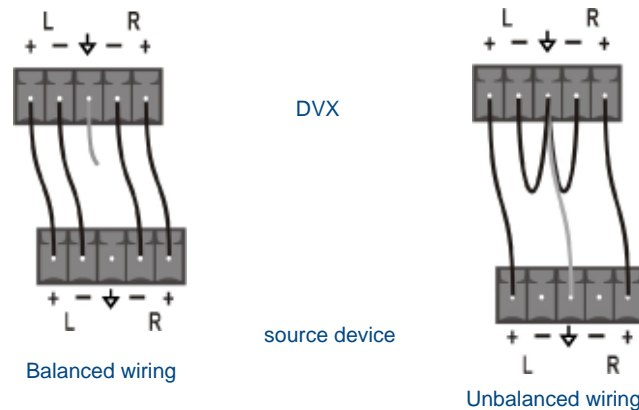

FIG. 28 Stereo 5-terminal wiring

FIG. 29 provides details for wiring from an audio input to a an unbalanced source device that has RCA connectors. Positive and ground wires connect to the source. You also can use a CC-3.5ST5-RCA2F 2 RCA Female to 5-Pin Phoenix Cable (FG10-003-20) for this type of connection.

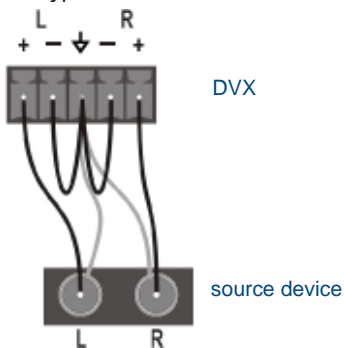

FIG. 29 RCA Stereo audio source wiring

CAUTION: Do not connect the negative terminals to the source connector. Doing so can cause damage to your device.

MIC/LINE INPUTS

Two 3.5mm 3-pin captive-wire MIC/LINE INPUT connectors allow up to two mono microphones to be connected to the DVX. Each microphone input supports balanced and unbalanced audio. Each input supports up to 48V of phantom power.

FIG. 30 displays the MIC/LINE INPUTS connectors.

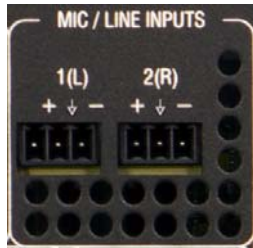

FIG. 30 MIC/LINE INPUTS

FIG. 31 illustrates wiring connections between the DVX and a mono RCA output and an XLR output.

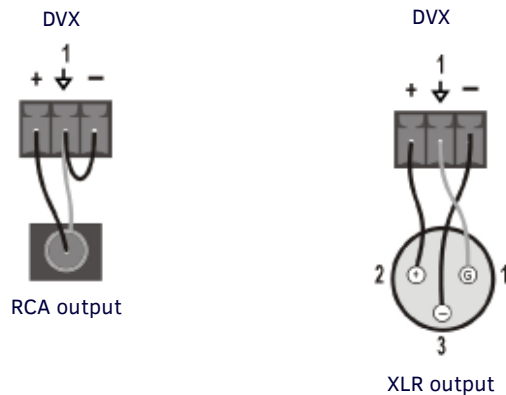

FIG. 31 RCA (mono) and XLR output wiring

AMP OUT

The AMP OUT amplified audio output differs according to the DVX model you are using:

- The 4-position captive wire connector for -SP models provides amplified, variable, mono or stereo audio output.
- The two 2-position captive wire connectors for -T models provide 70V or 100V mono amplified audio output. Connect a speaker to either the 70V or 100V terminal, but not both simultaneously.

FIG. 32 displays the AMP OUT audio output.

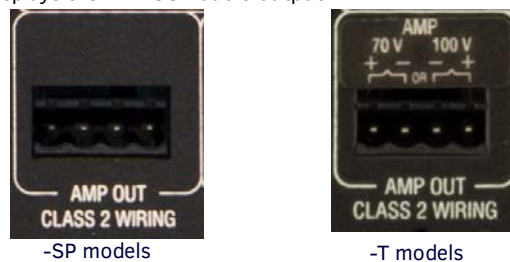

FIG. 32 AMP OUT CLASS 2 WIRING Output

On -SP models, connect speakers to the AMP OUT output as displayed in FIG. 33.

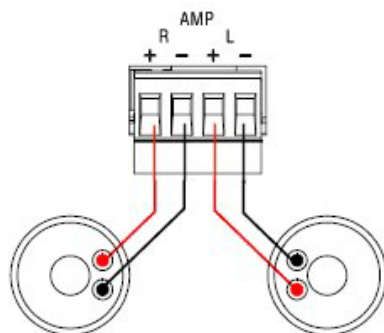

FIG. 33 Connecting speakers to the Amplified Audio output (-SP models)

On -T models, connect a speaker to either the 70V or 100V terminals as displayed in FIG. 34.

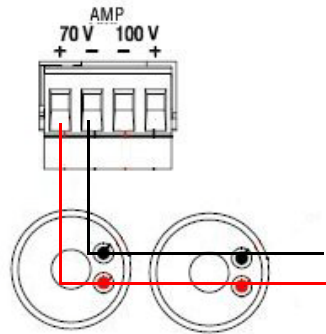

FIG. 34 Connecting speakers to the Amplified Audio output (-T models)

AUDIO OUTPUTS

The Line Level audio outputs provide balanced or unbalanced, mono or stereo line-level audio output. The 325x models each feature three audio outputs (ports 2-4). The 22xx models feature only two audio outputs each (ports 2-3).

FIG. 35 displays the AUDIO OUTPUTS connectors,

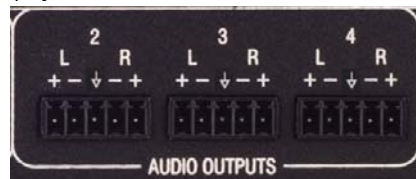

FIG. 35 AUDIO OUTPUTS

Destination devices require either balanced (differential) or unbalanced (single-ended) connections. FIG. 36 illustrates options for wiring between output connectors and the destinations.

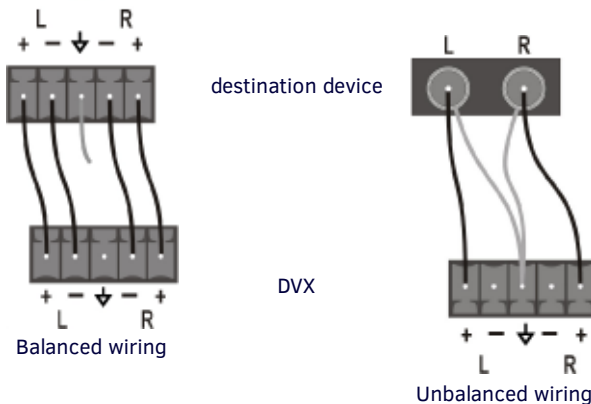

FIG. 36 Stereo 5-terminal wiring

CAUTION: Do not connect the negative terminals to the source connector. Doing so can cause damage to your device.

S/PDIF OUTPUT

The S/PDIF OUTPUT provides digital S/PDIF audio output that can mirror any of the analog audio outputs or HDMI outputs. FIG. 37 displays the S/PDIF OUTPUT connector.



FIG. 37 S/PDIF Output

Rear Panel Video Inputs and Outputs

The following sub-sections describe each component on the rear panel of the DVX. All digital inputs and outputs on the DVX support HDCP 1.4. Refer to FIG. 6 on page 24 for the component layout of the rear panel.

MULTI/FORMAT VIDEO INPUTS

The four MULTI/FORMAT VIDEO INPUT connectors on the rear panel are used to connect video source input devices to the DVX. The DVX routes video from connected source input devices to the connected output devices. The DVX-3250HD and 3255HD models each feature four audio outputs (ports 1-4). The DVX-3256HD and 22xx models feature only two audio outputs each (ports 1-2). FIG. 38 displays the MULTI/FORMAT VIDEO INPUT connectors.

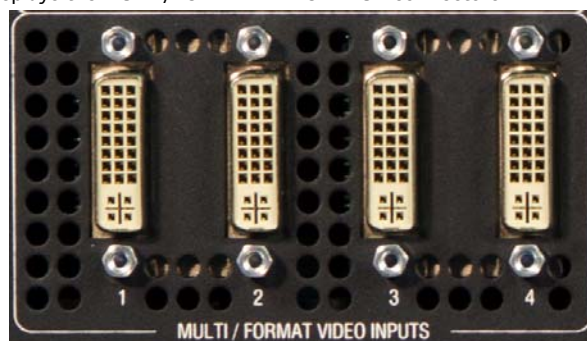

FIG. 38 MULTI/FORMAT VIDEO INPUTS (DVI-I connectors)

These numbered inputs correspond to the input port number of the video signal when making a switch or adjusting video input parameters.

NOTE: The MULTI/FORMAT VIDEO INPUT connectors on the DVX are DVI-I (integrated digital/analog) connectors. These connectors support both DVI-A (analog) and DVI-D (digital) inputs.

The following table describes the pinout configuration of the MULTI/FORMAT VIDEO INPUT connectors:

MULTI/FORMAT VIDEO INPUT Connectors - Pinouts and Signals					
Pin	Signal	Pin	Signal	Pin	Signal
1	TMDS Data2-	9	TMDS Data1-	17	TMDS Data0-
2	TMDS Data2+	10	TMDS Data1+	18	TMDS Data0+
3	TMDS Data2/4 Shield	11	TMDS Data1/3 Shield	19	TMDS Data0/5 Shield
4	n/c	12	n/c	20	n/c
5	n/c	13	n/c	21	n/c
6	DDC Clock [SCL]	14	+5 V Power	22	TMDS Clock Shield
7	DDC Data [SDA]	15	Ground (for +5 V)	23	TMDS Clock +
8	Analog vertical sync	16	Hot Plug Detect	24	TMDS Clock -
C1	Analog Red				
C2	Analog Green				
C3	Analog Blue				
C4	Analog Horizontal Sync				
C5	Analog Ground				
<p>NOTE: If a DVI source is attached before setting the input to DVI, you may need to reboot the source for it to recognize the DVI input description information required by the DVI standard.</p>					

Each MULTI/FORMAT VIDEO INPUT connector supports HDMI and DVI-D, as well as RGBHV, S-Video, Composite, Component, and VGA inputs, using the appropriate conversion cables. Refer to the *Cable Details and Pinout Information* section on page 49 for cable details and pinout information for each cable type:

- section on page 49
- *DVI-A Male to 5-BNC Male Cable* section on page 51
- *DVI-A Male to Triple RCA Male Cable* section on page 52
- *DVI-A Male to S-Video Male Cable* section on page 53
- *DVI-A Male to HD15 (VGA) Male Adapter* section on page 54
- *HDMI Male to DVI-D Male Cable* section on page 55

NOTE: The DVX and the adapter cables listed above utilize industry-standard pinouts. The only adapter cable that is unique to AMX is the *CC-DVI-SVID (DVI-to-S-Video)* cable. The others are generally available to purchase from other vendors, assuming that they also utilize industry standard (or equivalent) pinouts.

The following table displays the supported video settings for each type of input connection:

Supported Video Settings						
Type	Phase	Shift	Hue	Saturation	Contrast	Brightness
S-Video	X	X	✓	✓	✓	✓
Composite	X	X	✓	✓	✓	✓
Component	X	X	✓	✓	✓	✓
RGB	✓	✓	✓	✓	✓	✓
DVI	X	X	✓	✓	✓	✓
HDMI	X	X	✓	✓	✓	✓

NOTE: Deep Color pass-through is not supported on the MULTI/FORMAT VIDEO INPUTS.

HDMI INPUTS

The HDMI INPUT connectors on the rear panel are used to connect source input devices to the DVX. The DVX routes digital video and audio from connected source input devices to the connected output devices. These ports support HDMI (with 3D and Deep Color) and HDCP 1.4.

FIG. 39 displays the HDMI INPUTS connectors.

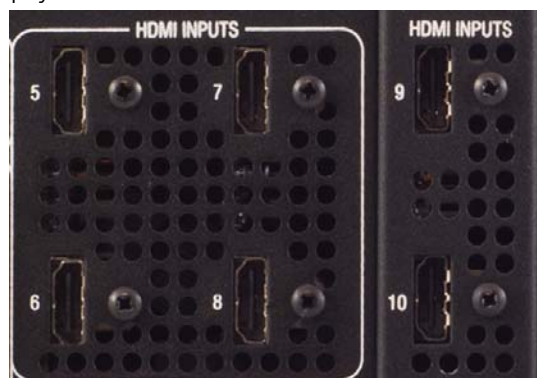

FIG. 39 HDMI INPUTS connectors

The following table lists the number of video ports and the port numbers for each model of DVX.

Digital Audio Ports				
DVX Model	No. of HDMI Ports	Port Numbers	No. of DXLink Ports	Port Numbers
DVX-3250HD	6	5-10	0	N/A
DVX-3255HD	4	5-8	2	9-10
DVX-3256HD	4	3-6	4	7-10
DVX-2250HD	4	5-8	0	N/A
DVX-2255HD	2	3-4	2	5-6
DVX-2210HD	2	3-4	0	N/A

The following table describes the pinout configuration of the HDMI INPUTS connectors:

HDMI INPUT Connectors - Pinouts and Signals			
Pin	Signal	Pin	Signal
1	TMDS Data 2+	11	TMDS Clock Shield
2	TMDS Data 2 Shield	12	TMDS Clock-
3	TMDS Data 2-	13	CEC
4	TMDS Data 1+	14	Reserved, HEC Data
5	TMDS Data 1 Shield	15	SCL
6	TMDS Data 1-	16	SDA
7	TMDS Data 0+	17	DDC/CEC/HEC Ground
8	TMDS Data 0 Shield	18	+5V Power (max 50mA)
9	TMDS Data 0-	19	Hot Plug Detect, HEC Data+
10	TMDS Clock+		

FIG. 40 displays the pin locations for the HDMI INPUTS:

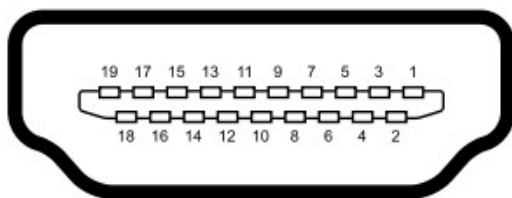

FIG. 40 HDMI pinouts

To connect HDMI input source devices (DVI and HDMI) to the HDMI INPUT connectors, the following (optional) adapter cables are required:

DVI Input Adapter Cables			
Name	Description	Length	FG#
HDMI Interface Cable	HDMI Male to HDMI Male	6 1/2' (2m)	FG10-2178-05
HDMI to DVI Cable	HDMI Male to DVI Male (See the <i>HDMI Male to DVI-D Male Cable</i> section on page 55 for more information on HDMI-to-DVI cable wiring.)	6' (1.828m)	FG10-2179

The following table displays the supported video settings for each type of input connection compatible with the HDMI INPUT connectors:

Supported Video Settings						
Type	Phase	Shift	Hue	Saturation	Contrast	Brightness
DVI	X	X	✓	✓	✓	✓
HDMI	X	X	✓	✓	✓	✓

DXLink INPUTS

Two DXLink (RJ-45) connectors transport digital video, embedded audio, Ethernet, and bi-directional control over twisted pair cable to DXLink devices or boards, including digitally transcoded analog video signals. Both inputs support HDCP 1.4. These connectors are not available on all DVX models. Consult the Digital Audio Ports table on page 36 for a list of DVX models that feature DXLink INPUTS connectors.

FIG. 41 displays the DXLINK INPUTS connectors.



FIG. 41 DXLINK INPUTS

See the *Important Twisted Pair Cabling Requirements and Recommendations* section on page 39 for information about cable requirements for these ports.

DXLINK/HDMI OUTPUTS

The following sections provide details on the video outputs for the 325x and 22xx DVX models.

325x Video Outputs

The DXLINK/HDMI OUTPUTS includes 2 different types of connectors:

- 4 HDMI Output connectors (1-4) each provide digital DVI video and HDMI audio and video output.
- 2 DXLink Twisted Pair outputs (1, 3) mirror HDMI outputs 1 and 3. They provide digital video, audio, Ethernet, and bi-directional control over Category Cable to DXLink Receivers. See the *Important Twisted Pair Cabling Requirements and Recommendations* section below for information about cable requirements.

NOTE: On Video outputs 1 and 3, if you are using both DXLink and HDMI outputs, it is recommended that they have the same native resolution. In this situation, the EDID from the HDMI display is used to determine the SmartScale resolution and timing.

FIG. 42 displays the HDMI and DXLink audio/video output ports.



FIG. 42 DXLINK/HDMI OUTPUTS

NOTE: All video output ports support HDCP 1.4.

22xx Video Outputs

The VIDEO OUTPUTS for the 22xx DVX models include 2 different types of connectors:

- 2 HDMI Output connectors (1-2) each provide scaled digital DVI video and HDMI audio and video output.
- 1 DXLink Twisted Pair output (3) providing digital video, embedded audio, Ethernet (ICSP commands only), and bi-directional control and power over Category Cable to DXLink Receivers. Video output on the DXLink port is NOT scaled. See the *Important Twisted Pair Cabling Requirements and Recommendations* section on page 39 information about cable requirements.

NOTE: The DVX-2210HD features 1 DXLink Twisted Pair output (1) which mirrors HDMI port 1. It provides digital video, audio, Ethernet, and bi-directional control over Twisted Pair Cable to DXLink Receivers.

FIG. 43 displays the HDMI and DXLink audio/video output ports on the DVX-2250HD-SP:

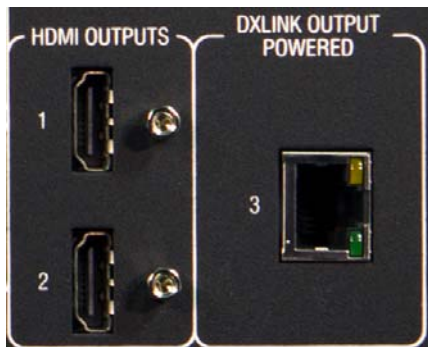

FIG. 43 VIDEO OUTPUTS

NOTE: All video output ports support HDCP 1.4.

FIG. 44 displays male and female RJ-45 connectors. You can connect the DVX to the DXLink receivers via Category cabling.

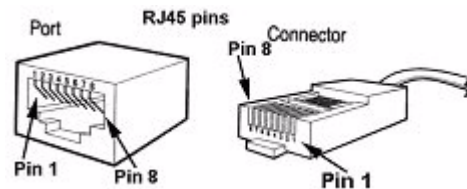

FIG. 44 RJ-45 Pinouts

Twisted Pair Cable Pinouts

AMX supports both the T568A and T568B pinout specifications for termination of the twisted pair cable used between the DVX and the DXLink receiver.

FIG. 45 displays the twisted pair pinouts for T568A and T568B specifications.

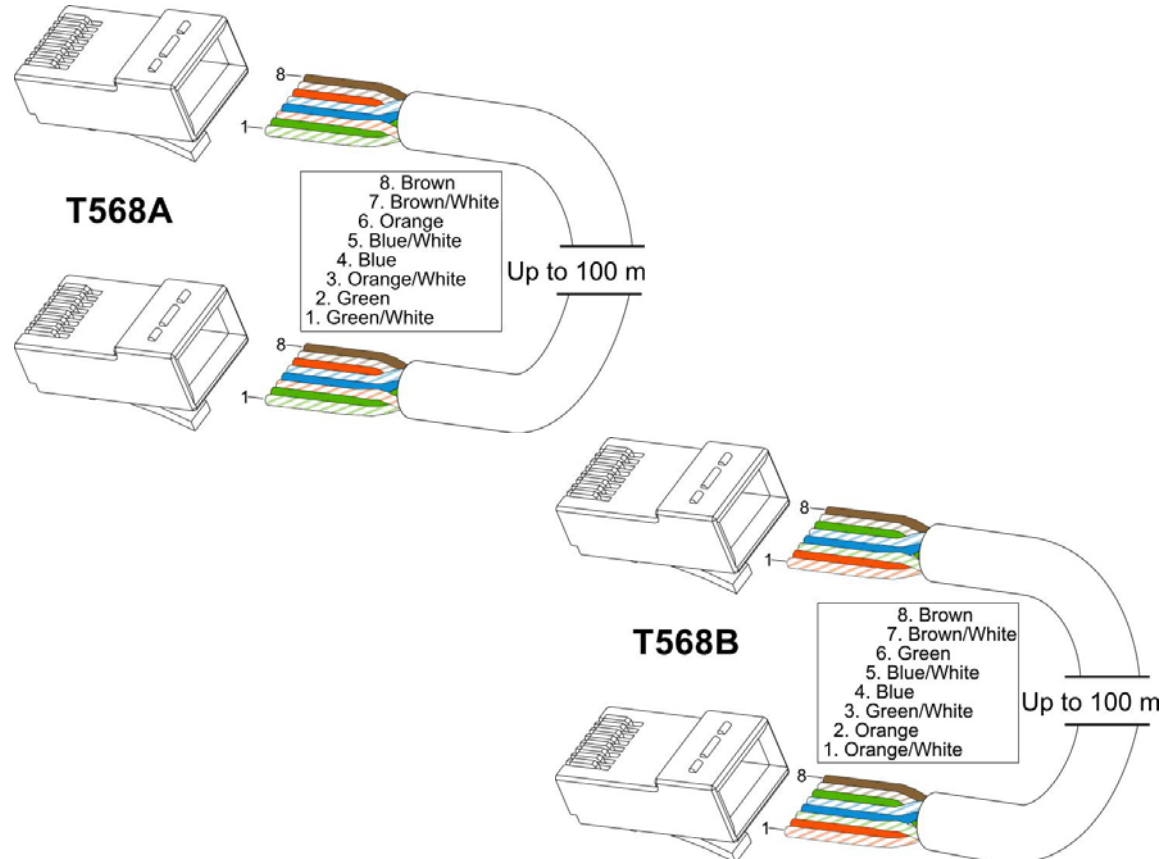

FIG. 45 Twisted pair cable pinouts for T568A (recommended) and T568B specifications

Important Twisted Pair Cabling Requirements and Recommendations

The following requirements and recommendations apply to cabling DXLink (RJ-45) connectors:

- DXLink cable runs require shielded category cable (STP) of Cat6 (or better).
- DXLink twisted pair cable runs for DXLink equipment shall only be run within a common building.*
- DXLink delivers 10.2 Gb/s throughput over shielded category cable. Based on this bandwidth requirement, we recommend following industry standard practices designed for 10 Gigabit Ethernet when designing and installing the cable infrastructure.
- The cables should be no longer than necessary to reach the end-points. We recommend terminating the cable to the actual distance required rather than leaving any excess cable in a service loop.

For more details and helpful cabling information, reference the white paper titled "Cabling for Success with DXLink" available at www.amx.com or contact your AMX representative.

* "Common building" is defined as: Where the walls of the structure(s) are physically connected and the structure(s) share a single ground reference.

Rear Panel Control and Power

The following sub-sections describe each component on the rear panel of the DVX. Refer to FIG. 6 on page 24 for the component layout of the rear panel.

Serial Ports

The DVX features device control serial ports that support either RS-232 or RS-422, and RS-485 communication protocols. Each port supports the following specifications:

- XON/XOFF (transmit on/transmit off)
- CTS/RTS (clear to send/ready to send)
- 300-115,200 baud rate

RS-232 Ports

The RS-232 ports (ports 2-4 and 6-8 on the DVX-325xHD; ports 2-4 on the DVX-22xxHD) are 5-pin 3.5 mm mini-Phoenix (male) connectors used for connecting A/V sources and displays. These ports support most standard RS-232 communication protocols for data transmission.

FIG. 46 displays the RS-232 ports for the DVX.

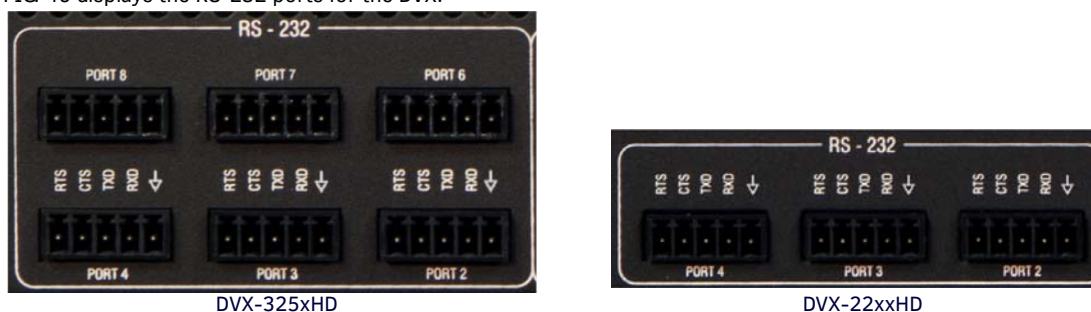

FIG. 46 RS-232 ports

The following table lists the pinouts for the RS-232 ports.

RS-232 Port Pinouts	
Pin 1	GND
Pin 2	RXD
Pin 3	TXD
Pin 4	CTS
Pin 5	RTS

In the above table, pin 1 is located on the right side of the port, and the pinouts count up to the left.

RS-232/422/485 Ports

The RS-232/422/485 ports (ports 1 and 5 on the DVX-325x; port 1 on the DVX-22xx) are 10-pin 3.5 mm mini-Phoenix (male) connectors used for connecting A/V sources and displays. By default, these ports are RS-422- and RS-485-disabled ports. These ports can be used as RS-232 ports by disabling RS-422 and RS-485 on the ports. Only with RS-422/485 disabled will the ports operate as RS-232. See the *SET BAUD* command and the *TSET BAUD* command in the NetLinX Programming chapter of the NX-Series Controllers WebConsole and Programming Guide for more information on disabling RS-422 and RS-485 on these ports. These ports support most standard RS-232, RS-422, and RS-485 communication protocols for data transmission.

FIG. 47 displays the RS-232/422/485 ports for each DVX model.



FIG. 47 RS-232/422/485 ports

The following table lists the pinouts for the RS-232/422/485 ports.

RS-232/422/485 Port Pinouts	
Pin 1	GND (used in RS-232 and RS-422)
Pin 2	RXD (used in RS-232)
Pin 3	TXD (used in RS-232)
Pin 4	CTS (used in RS-232)
Pin 5	RTS (used in RS-232)
Pin 6	TX+ (used in RS-422 and RS-485)
Pin 7	TX- (used in RS-422 and RS-485)
Pin 8	RX+ (used in RS-422 and RS-485)
Pin 9	RX- (used in RS-422 and RS-485)
Pin 10	+12V

In the above table, pin 1 is located on the right side of the port, and the pinouts count up to the left.

Relay Ports

The relay ports (port 21 on the DVX) are 8-pin 3.5 mm mini-Phoenix (male) connectors used for connecting external relay devices. The DVX-325xHD features 2 sets of 8-pin relay connectors. The DVX-22xxHD features one set of connectors. You can connect up to 8 independent external relay devices on the DVX-325xHD, and 4 on the DVX-22xxHD. When a relay is "OFF", terminals A and B are open-circuit. When a relay is "ON", terminals A and B are shorted together.

Relay Connections

Use connectors A for common and B for output (FIG. 48). Each relay is isolated and normally open. A metal connector strip is also provided to common multiple relays.

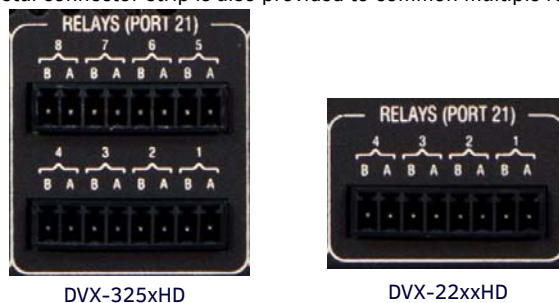

FIG. 48 RELAY connector (male)

- 8-channel single-pole single-throw relay ports
- Each relay is independently controlled
- Supports up to 8 independent external relay devices (4 on the DVX-22xxHD)
- Channel range = 1-8
- Each relay can switch up to 24 VDC or 28 VAC peak @ 1 A
- Two 8-pin 3.5mm mini-Phoenix (male) connector provides relay termination (One connector on the DVX-22xxHD)

I/O Ports

The I/O ports (port 22 on the DVX) are 6-pin 3.5 mm mini-Phoenix (male) connectors used for connecting logic-level outputs. The DVX-325xHD features 2 sets of 6-pin I/O connectors; the DVX-22xxHD features 1 6-pin connector. The I/O port responds to either switch closures, voltage level (high/low) changes, or it can be used for logic-level outputs. Each port is capable of being used as an input or an output.

FIG. 49 displays the I/O ports for each DVX model.



FIG. 49 I/O ports

- A contact closure between the GND and an I/O port is detected as a Push.
- When used for voltage inputs, the I/O port detects a low signal (0 - 1.5 VDC) as a Push, and a high signal (3.5 - 5 VDC) as a Release. (This I/O port uses 5V logic but can handle up to 12V without harm).
- When used for outputs, the I/O port acts as a switch to GND and is rated for 200mA @ 12 VDC.
- The DVX-22xxHD can use up to 4 I/O ports
- The DVX-325xHD can use up to 8 I/O ports
- The PWR pin provides +12 VDC @ 200 mA and is designed as a power output for the PCS Power Current Sensors, VSS2 Video Sync Sensors (or equivalent).
- The GND connector is a common ground and is shared by all I/O ports. A common ground is shared with I/O ports 1-8 (DVX-325xHD) or with I/O ports 1-4 (DVX-22xxHD).
- The input impedance on the I/O port is 22k.

I/O Port Wiring Specifications					
DVX-325xHD			DVX-22xxHD		
Pin	Signal	Function	Pin	Signal	Function
1	GND	Signal GND	1	GND	Signal GND
2	I/O 1	Input/Output	2	I/O 1	Input/Output
3	I/O 2	Input/Output	3	I/O 2	Input/Output
4	I/O 3	Input/Output	4	I/O 3	Input/Output
5	I/O 4	Input/Output	5	I/O 4	Input/Output
6	12 VDC	PWR	6	12 VDC	PWR
7	GND	Signal GND			
8	I/O 5	Input/Output			
9	I/O 6	Input/Output			
10	I/O 7	Input/Output			
11	I/O 8	Input/Output			
12	12 VDC	PWR			

In the above table, pin 1 is located on the right side of the port, and the pinouts count up to the left.

IR/SERIAL Port: Connections and Wiring

The IR/SERIAL ports provide IR transmit/one-way serial connections that support high-frequency carriers up to 1.142 MHz. You can simultaneously generate up to eight IR/Serial data signals on the DVX-325xHD, and up to four on the DVX-22xHD.

These ports accept an IR Emitter (CC-NIRC) that mounts onto the device's IR window, or a mini-plug (CC-NSER) that connects to the device's control jack. You can also connect a data 0 - 5 VDC device to these ports.

DVX-325xHD units ship with two CC-NIRC IR Emitters (**FG10-000-11**). DVX-22xHD units ship with one emitter.

FIG. 50 displays the IR/SERIAL ports for each DVX model.

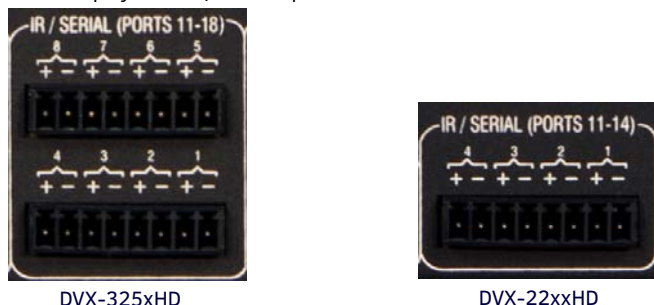

FIG. 50 IR/SERIAL connector (male)

NOTE: The maximum baud rate for ports using DATA mode is 19200. Also, DATA mode works best when using a short cable length (< 10 feet).

NOTE: For each data signal, the negative (-) terminal is for Signal GND, and the positive (+) terminal is for IR/Serial data.

The IR/Serial connector wiring specifications are listed in the following table.

IR/SERIAL Connector Wiring Specifications (per Port)		
Signal #	DVX-325xHD Port #	DVX-22xxHD Port #
1	11	11
2	12	12
3	13	13
4	14	14
5	15	N/A
6	16	N/A
7	17	N/A
8	18	N/A

AxLink Port and LED (4-pin captive-wire)

The AxLink port allows the central controller to support AMX AxLink devices.

FIG. 51 displays the AXLINK ports for each DVX model.



FIG. 51 AxLink Ports and LEDs

The (green) AxLink LED indicates AxLink data activity:

- **Off** - No power, or the controller is not functioning properly.
- **1 blink per second** - Normal operation.
- **3 blinks per second** - AxLink bus error. Check all AxLink bus connections.

The AxLink port can be used to supply power to downstream AxLink-compatible devices as long as the maximum current draw is less than 0.5 Amps on the DVX-22xHD, and 3 Amps on the DVX-325xHD. To isolate the central controller from high in-rush current, AxLink devices, or potential power faults on the AxLink bus, it is strongly recommended that you power external AxLink devices from an independent power supply.

NOTE: The AxLink port provides only limited power to connected AxLink devices. It is recommended to use an alternate power source when connecting AxLink devices to the central controller.

IMPORTANT: The DVX CANNOT be powered via the AxLink port. The +12V pin on the AxLink connectors are designed only for voltage output. Do NOT connect +12V from a power supply or the NXA-PDU to the +12V pin on the AxLink connectors, or you may permanently damage the DVX and/or the power supply.

The DVX-325xHD has two AxLink connections. These are two connection points for the same AxLink bus. All AxLink devices connected to the controller must have unique AxLink device numbers even if they are attached to different AxLink connection points on the controller.

While it is one AxLink bus, the power on these two AxLink connections is controlled independently.

Refer to the following table for the wiring length information used with the central controller:

Wiring Guidelines	
Wire size	Maximum wiring length
18 AWG	154.83 feet (47.19 meters)
20 AWG	98.30 feet (29.96 meters)
22 AWG	63.40 feet (19.32 meters)
24 AWG	38.68 feet (11.79 meters)

FIG. 52 provides wiring requirements for the AxLink connector:

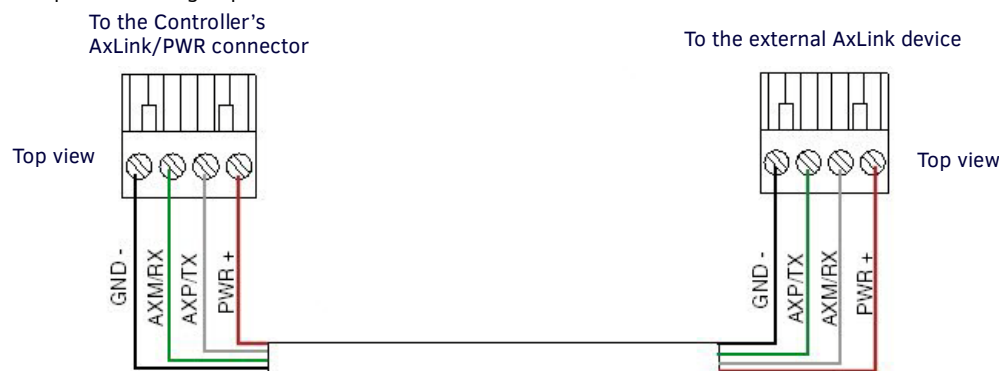

FIG. 52 Mini-Phoenix connector wiring diagram (direct data and power)

To use the 4-pin 3.5 mm mini-Phoenix (male) captive-wire connector for data communication and power transfer, the incoming PWR and GND cable from the 12 VDC-compliant power supply must be connected to the AxLink cable connector going to the central controller. FIG. 53 shows the wiring diagram:

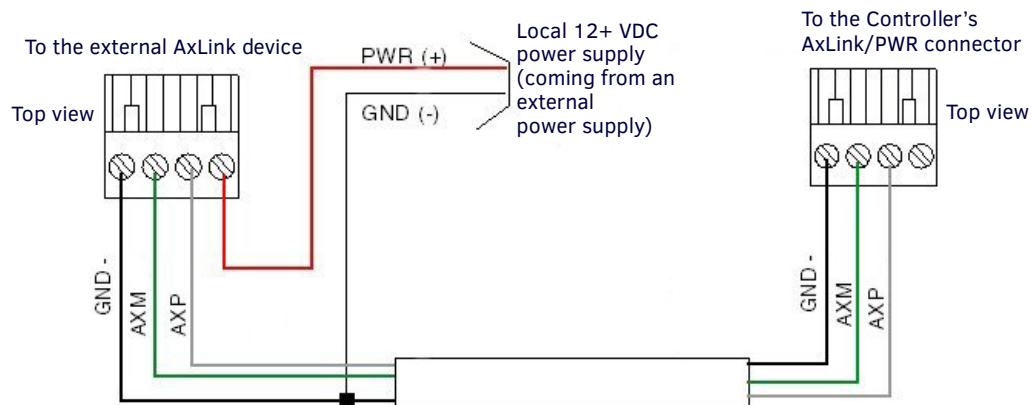

FIG. 53 4-pin mini-Phoenix connector wiring diagram (using external power source)

CAUTION: When you connect an external power supply, do not connect the wire from the PWR terminal (coming from the external device) to the PWR terminal on the Phoenix connector attached to the Controller unit. Make sure to connect only the AXM, AXP, and GND wires to the Controller's Phoenix connector when using an external power supply.

Make sure to connect only the GND wire on the AxLink/PWR connector when using a separate 12 VDC power supply. Do not connect the PWR wire to the AxLink connector's PWR (+) opening.

SDHC Card Slot

The DVX-325xHD features an externally accessible SDHC card slot.

NOTE: *The card slot is reserved for future use. Do not install a card in the card slot at this time.*

FIG. 54 displays the SDHC card slot.



FIG. 54 SDHC Card Slot

Configuration DIP Switch

All DVX models have a configuration DIP switch which allows for certain operations to occur during boot-time. The DIP switch positions are assigned as follows:

- Switch for Program Run Disable
- Switch for Boot from External SD Card (only applicable to the DVX-325xHD.)

FIG. 55 displays the Configuration DIP Switch for the DVX.



FIG. 55 Configuration DIP Switch

Program Run Disable (PRD) Mode

You can use the Configuration DIP switch to set the on-board Master to Program Run Disable (PRD) mode. PRD mode prevents the NetLinX program stored in the on-board Master from running when you power up the Integrated Controller. You should only use PRD mode when you suspect the resident NetLinX program is causing inadvertent communication and/or control problems.

If necessary, place the on-board Master in PRD mode and use the NetLinX Studio program to resolve the communication and/or control problems with the resident NetLinX program. Then download the new NetLinX program and try again.

FIG. 56 displays the default DIP switch settings and the settings for PRD mode. To switch to PRD mode, move the position 1 DIP switch to ON.

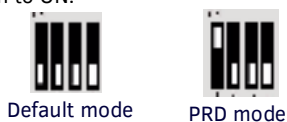

FIG. 56 DIP Switch settings - PRD mode

NOTE: *Consider equating PRD Mode to a PC's SAFE Mode setting. With PRD mode, you can continue to power a unit, update the firmware, and download a new program while circumventing any problems with a currently downloaded program. You must power cycle the unit after activating/deactivating PRD mode on Program Port DIP switch #1.*

ICSLAN Ports

All DVX models have two types of Ethernet ports: LAN and ICSLAN. The LAN port is used to connect the master to an external network, and the ICSLAN ports are used to connect to other AMX equipment or third-party A/V equipment. The ICSLAN ports on all models provide Ethernet Communication to connected AMX Ethernet Equipment in a way that is isolated from the primary LAN connection.

The ICSLAN port is a 10/100 Port RJ-45 connector and Auto MDI/MDI-X enabled. Each model of DVX features one port. The port support IPv4 and IPv6 networks, as well as HTTP, HTTPS, Telnet, and FTP.



FIG. 57 ICSLAN port

The ICSLAN port gets its IP addresses in one or more of the following ways:

- IPv4 - Static assignment of the subnetwork address by the user
- IPv6 - Link local address

Using the ICSLAN Network

The default IP address for the ICSLAN network is 198.18.0.1 with a subnet mask of 255.255.0.0.

It is important that the ICSLAN and LAN subnets do not overlap. If the LAN port is configured such that its address space overlaps with the ICSLAN network, the ICSLAN network will be DISABLED.

NOTE: *Typically, the DVX communicates with an A/V switcher via ICSLAN. Since the A/V switcher has a static IP address on the ICSLAN network, and you cannot change the IP address on the switcher, you cannot change the 198.18 subnet information on the DVX platform of processors. You can only change the Host name and DHCP server settings.*

DHCP Server

The ICSLAN port has a built-in DHCP server. This DHCP server is enabled by default and will serve IP addresses to any connected devices set to DHCP mode.

The DHCP server can be disabled from telnet with the command:

```
SET ICSLAN
```

The DHCP address range is fixed. The server will provide addresses in the range x.x.0.2 through x.x.63.255.

Devices using static IP addresses on the ICSLAN network should be set within the reserved static IP address range of x.x.64.1 to x.x.255.255.

Opening LAN and ICSLAN Sockets from Code

When opening sockets from NetLinx or Java code there is no mechanism to indicate which network to use. The controller will open the socket on whichever network has an IP subnet that matches the address provided in the command to open the socket. There is no indication which network was used, only whether the socket was created successfully.

USB Port

All DVX models feature one Type-A USB port you can use to connect a mass storage device for loading .jar files and IR data files (.irl), reading or writing configuration files and log files, or updating the firmware on the unit.

NOTE: *This USB port only supports a FAT32 file system.*

This USB port (FIG. 58) uses standard USB cabling to connect to any mass storage or peripheral devices.



FIG. 58 USB port

NOTE: *USB hubs are not supported on this port.*

ID Pushbutton

All DVX models feature an ID pushbutton which you can use to toggle between static and dynamic IP addressing. You can also use the pushbutton to reset the default settings on the controller or restore the controller to its factory firmware image.

FIG. 59 displays the ID pushbutton for the DVX.



FIG. 59 ID pushbutton

Switching to Static or Dynamic IP Addressing.

To toggle between static or dynamic IP addressing, the controller cannot be currently booting or it must be in ID Mode. If these conditions are met, holding the ID pushbutton for 10 seconds changes the current IP addressing mode.

Restoring the Controller Settings to the Factory Defaults

To restore the controller settings to the factory defaults, the controller must be currently booting and you must press the ID pushbutton for 10 seconds. The controller is booting when the System and Input LEDs are both ON and the Output LED is OFF. This includes resetting the static IP address to its default and deleting the NetLinx program.

CAUTION: *Pressing the ID pushbutton for 20 seconds restores the factory firmware image on the controller. Do not press the pushbutton significantly longer than the necessary 10 seconds if you only want to restore the default settings on the controller.*

Restoring the Controller's Factory Firmware Image

To restore the controller's factory firmware image, the controller must currently be booting and you must press the ID pushbutton for 20 seconds. This also deletes all code and IRL files.

LAN 10/100 Port

All DVX models feature a LAN 10/100 port to provide 10/100 Mbps communication via Category cable. This is an Auto MDI/MDI-X enabled port, which allows you to use either straight-through or crossover Ethernet cables. The port support IPv4 and IPv6 networks, as well as HTTP, HTTPS, Telnet, and FTP.

The LAN port automatically negotiates the connection speed (10 Mbps or 100 Mbps), and whether to use half duplex or full duplex mode.

FIG. 60 displays the LAN port for the DVX.



FIG. 60 LAN 10/100 port

FIG. 61 provides the pinouts and signals for the LAN connector and cable.

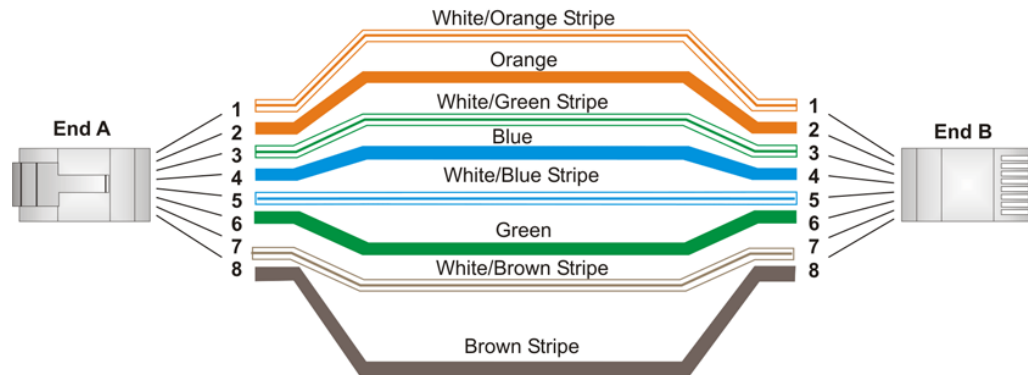

FIG. 61 RJ-45 wiring diagram

FIG. 62 describes the blink activity for the LAN connector and cable.

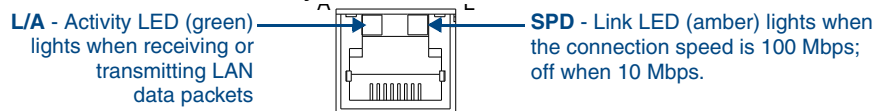

FIG. 62 LAN connector / LEDs

The LAN port gets its IP address(es) in one or more of the following ways:

IPv4

- Static assignment by the user
- Dynamic assignment by an IPv4 DHCP server
- Link local as a fall back when configured for DHCP but unable to successfully obtain address

IPv6

- Link local address
- Prefix(es) assigned by a router

Power Connector/Switch/Fuse

FIG. 63 displays the power switch and connector for the DVX.

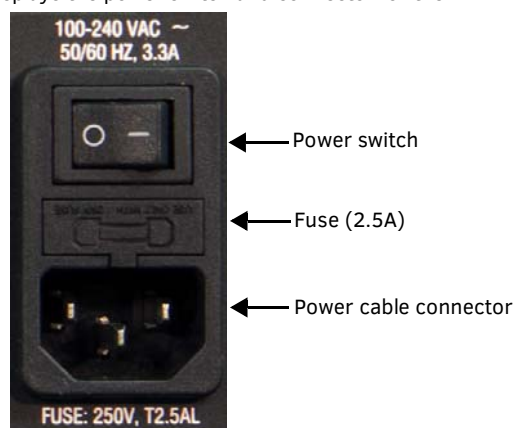

FIG. 63 Power Connector/Switch/Fuse

CAUTION: *This unit should only have one source of incoming power. Using more than one source of power to the Controller can result in damage to the internal components and a possible burn out. Apply power to the unit only after installation is complete.*

Cable Details and Pinout Information

Overview

The DVI-I Input connectors on the rear panel are used to connect video source input devices to the DVX. The DVX routes video from connected source input devices to the connected output device. Each connector supports HDMI and DVI as well as VGA, S-Video, Composite, and Component inputs.

FIG. 64 displays the DVI inputs.

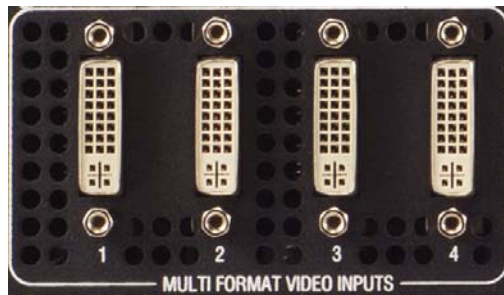

FIG. 64 DVI inputs

To connect non-DVI input source devices (S-Video, Composite, VGA, Component, and HDMI) to the DVI Input connectors, the following (optional) adapter cables are required:

DVI Input Adapter Cables			
Name	Description	Length	FG#
CC-DVI-5BNM	DVI-to-5 BNC Male NOTE: Used for VGA, Component, or Composite inputs. When used for composite inputs, connect the green plug on the adapter cable to the composite video output jack on the source device.	6' (1.828m)	FG10-2170-08
CC-DVI-RCA3M	DVI-to-3 RCA Male NOTE: Used for Component or Composite inputs. When used for composite inputs, connect the green plug on the adapter cable to the composite video output jack on the source device.	6' (1.828m)	FG10-2170-09
CC-DVI-SVID	DVI-to-S-Video	9' (2.743m)	FG10-2170-10
CC-DVIM-VGAF	DVI-to-VGA (up to 1920x1200)	6' (1.828m)	FG10-2170-13

DVI-D Male to DVI-D Male Single-Link Cable

Cable to be composed of the following:

- Four UL20276 (28AWG twisted pair + drain wire + aluminum foil/mylar shield) for TMDS signals and shields
- Five UL1589 (28AWG) for DDC_CLK, DDC_DATA, Hot_Plug_Detect, +5VDC, and GROUND
- The above bundles jacketed together in aluminum foil shield and 85% (minimum) braid
- EMI shield metal can on both DVI connectors and connected to braid

DVI-to-DVI Cable Pinout Information

The following table lists DVI-to-DVI cable pinouts:

DVI-to-DVI Cable Pinout Information				
DVI-D Connector Pin	Signal Name	Signal Name	DVI-D Connector Pin	Notes:
1	TMDS DATA 2 N	TMDS DATA 2 N	1	28AWG twisted pair 2
2	TMDS DATA 2 P	TMDS DATA 2 P	2	28AWG twisted pair 2
3	TMDS SHIELD 2/4	TMDS SHIELD 2/4	3	28AWG twisted pair 2 drain
4	TMDS DATA 4 N	TMDS DATA 4 N	4	Pin not populated in DVI-D connector
5	TMDS DATA 4 P	TMDS DATA 4 P	5	Pin not populated in DVI-D connector
6	DDC CLOCK	DDC CLOCK	6	28AWG
7	DDC DATA	DDC DATA	7	28AWG
8	ANALOG VERTICAL SYNC	ANALOG VERTICAL SYNC	8	Pin populated in DVI-D connector, but not connected for this cable
9	TMDS DATA 1 N	TMDS DATA 1 N	9	28AWG twisted pair 1
10	TMDS DATA 1 P	TMDS DATA 1 P	10	28AWG twisted pair 1
11	TMDS SHIELD 1/3	TMDS SHIELD 1/3	11	28AWG twisted pair 1 drain
12	TMDS DATA 3 N	TMDS DATA 3 N	12	Pin not populated in DVI-D connector
13	TMDS DATA 3 P	TMDS DATA 3 P	13	Pin not populated in DVI-D connector
14	+5VDC	+5VDC	14	28AWG
15	GROUND	GROUND	15	28AWG
16	HOT PLUG DETECT	HOT PLUG DETECT	16	28AWG
17	TMDS DATA 0 N	TMDS DATA 0 N	17	28AWG twisted pair 0
18	TMDS DATA 0 P	TMDS DATA 0 P	18	28AWG twisted pair 0
19	TMDS SHIELD 0/5	TMDS SHIELD 0/5	19	28AWG twisted pair 0 drain
20	TMDS DATA 5 N	TMDS DATA 5 N	20	Pin not populated in DVI-D connector
21	TMDS DATA 5 P	TMDS DATA 5 P	21	Pin not populated in DVI-D connector
22	TMDS CLOCK SHIELD	TMDS CLOCK SHIELD	22	28AWG twisted pair CLK drain
23	TMDS CLOCK P	TMDS CLOCK P	23	28AWG twisted pair CLK
24	TMDS CLOCK N	TMDS CLOCK N	24	28AWG twisted pair CLK
C1	C1 ANALOG RED	C1 ANALOG RED	C1	Pin not populated in DVI-D connector
C2	C2 ANALOG GREEN	C2 ANALOG GREEN	C2	Pin not populated in DVI-D connector
C3	C3 ANALOG BLUE	C3 ANALOG BLUE	C3	Pin not populated in DVI-D connector
C4	C4 ANALOG HSYNC	C4 ANALOG HSYNC	C4	Pin not populated in DVI-D connector
C5	C5 ANALOG GROUND	C5 ANALOG GROUND	C5	Pin populated in DVI-D connector, but not connected for this cable
BACKSHELL	SHIELD	SHIELD	BACKSHELL	Outer braid

DVI-A Male to 5-BNC Male Cable

Cable to be composed of the following:

- Five 75ohm 28 AWG mini-coax cables for the Red, Green, Blue, VSync, and HSync signals and returns
- EMI shield metal can on DVI connector

NOTE: This cable type corresponds to the CC-DVI-5BNM DVI-to-Component cable (FG10-2170-08), available from AMX.

DVI-to-5-BNC Cable Pinout Information

The following table lists DVI--to-5-BNC cable pinouts:

DVI-to-5-BNC Cable Pinout Information				
DVI-A Connector Pin	Signal Name	Signal Name	BNC connector pin	Notes:
1	TMDS DATA 2 N			Pin populated in DVI-A connector, but not connected for this cable
2	TMDS DATA 2 P			Pin populated in DVI-A connector, but not connected for this cable
3	TMDS SHIELD 2/4			Pin not populated in DVI-A connector
4	TMDS DATA 4 N			Pin not populated in DVI-A connector
5	TMDS DATA 4 P			Pin not populated in DVI-A connector
6	DDC CLOCK			Pin populated in DVI-A connector, but not connected for this cable
7	DDC DATA			Pin populated in DVI-A connector, but not connected for this cable
8	ANALOG VERTICAL SYNC	VSync Signal	Black BNC center pin	
9	TMDS DATA 1 N			Pin not populated in DVI-A connector
10	TMDS DATA 1 P			Pin not populated in DVI-A connector
11	TMDS SHIELD 1/3			Pin not populated in DVI-A connector
12	TMDS DATA 3 N			Pin not populated in DVI-A connector
13	TMDS DATA 3 P			Pin not populated in DVI-A connector
14	+5VDC			Pin populated in DVI-A connector, but not connected for this cable
15	GROUND	VSync, HSync Returns (shields)	Black/Grey BNC shields	
16	HOT PLUG DETECT			Pin populated in DVI-A connector, but not connected for this cable
17	TMDS DATA 0 N			Pin populated in DVI-A connector, but not connected for this cable
18	TMDS DATA 0 P			Pin populated in DVI-A connector, but not connected for this cable
19	TMDS SHIELD 0/5			Pin not populated in DVI-A connector
20	TMDS DATA 5 N			Pin not populated in DVI-A connector
21	TMDS DATA 5 P			Pin not populated in DVI-A connector
22	TMDS CLOCK SHIELD			Pin not populated in DVI-A connector
23	TMDS CLOCK P			Pin populated in DVI-A connector, but not connected for this cable
24	TMDS CLOCK N			Pin populated in DVI-A connector, but not connected for this cable
C1	C1 ANALOG RED	Red Signal	Red BNC center pin	
C2	C2 ANALOG GREEN	Green Signal	Green BNC center pin	
C3	C3 ANALOG BLUE	Blue Signal	Blue BNC center pin	
C4	C4 ANALOG HSYNC	HSync Signal	Grey BNC center pin	
C5	C5 ANALOG GROUND	Red, Green, Blue Returns (shields)	Red/Green/Blue BNC shields	

DVI-to-5-BNC Cable Pinout Information (Cont.)				
DVI-A Connector Pin	Signal Name	Signal Name	BNC connector pin	Notes:
BACKSHELL	SHIELD			Pin populated in DVI-A connector, but not connected for this cable

DVI-A Male to Triple RCA Male Cable

Cable to be composed of the following:

- Three 75ohm 28 AWG mini-coax cables for the Red, Green, and Blue signals and returns
- EMI shield metal can on DVI connector

NOTE: This cable type corresponds to the CC-DVI-RCA3M DVI-to-Component/Composite cable (FG10-2170-09), available from AMX.

DVI-to-Triple RCA Cable Pinout Information

The following table lists the DVI-to-Triple RCA cable pinouts:

DVI-to-Triple RCA Cable Pinout Information				
DVI-A Connector Pin	Signal Name	Signal Name	RCA connector pin	Notes:
1	TMDS DATA 2 N			Pin populated in DVI-A connector, but not connected for this cable
2	TMDS DATA 2 P			Pin populated in DVI-A connector, but not connected for this cable
3	TMDS SHIELD 2/4			Pin not populated in DVI-A connector
4	TMDS DATA 4 N			Pin not populated in DVI-A connector
5	TMDS DATA 4 P			Pin not populated in DVI-A connector
6	DDC CLOCK			Pin populated in DVI-A connector, but not connected for this cable
7	DDC DATA			Pin populated in DVI-A connector, but not connected for this cable
8	ANALOG VERTICAL SYNC			Pin populated in DVI-A connector, but not connected for this cable
9	TMDS DATA 1 N			Pin not populated in DVI-A connector
10	TMDS DATA 1 P			Pin not populated in DVI-A connector
11	TMDS SHIELD 1/3			Pin not populated in DVI-A connector
12	TMDS DATA 3 N			Pin not populated in DVI-A connector
13	TMDS DATA 3 P			Pin not populated in DVI-A connector
14	+5VDC			Pin populated in DVI-A connector, but not connected for this cable
15	GROUND			Pin populated in DVI-A connector, but not connected for this cable
16	HOT PLUG DETECT			Pin populated in DVI-A connector, but not connected for this cable
17	TMDS DATA 0 N			Pin populated in DVI-A connector, but not connected for this cable
18	TMDS DATA 0 P			Pin populated in DVI-A connector, but not connected for this cable
19	TMDS SHIELD 0/5			Pin not populated in DVI-A connector
20	TMDS DATA 5 N			Pin not populated in DVI-A connector
21	TMDS DATA 5 P			Pin not populated in DVI-A connector
22	TMDS CLOCK SHIELD			Pin not populated in DVI-A connector
23	TMDS CLOCK P			Pin populated in DVI-A connector, but not connected for this cable
24	TMDS CLOCK N			Pin populated in DVI-A connector, but not connected for this cable
C1	C1 ANALOG RED	Component Pr / CVBS 1 Signal	Red RCA connector center pin	

DVI-to-Triple RCA Cable Pinout Information (Cont.)				
DVI-A Connector Pin	Signal Name	Signal Name	RCA connector pin	Notes:
C2	C2 ANALOG GREEN	Component Y / CVBS 2 Signal	Green RCA connector center pin	
C3	C3 ANALOG BLUE	Component Pb / CVBS 3 Signal	Blue RCA connector center pin	
C4	C4 ANALOG HSYNC			Pin populated in DVI-A connector, but not connected for this cable
C5	C5 ANALOG GROUND	Pr, Y, Pb / CVBS Returns (shields)	Red/Green/Blue RCA connector shields	
BACKSHELL	SHIELD			Pin populated in DVI-A connector, but not connected for this cable

DVI-A Male to S-Video Male Cable

Cable to be composed of the following:

- Two 75ohm 28 AWG mini-coax cables for the Luminance (Y) and Chrominance (C) signals and returns
- EMI shield metal can on DVI connector

NOTE: This cable corresponds to the CC-DVI-SVID DVI-to-S-Video adapter cable (FG10-2170-10), available from AMX.

DVI-to-S-Video Cable Pinout Information

The following table lists the DVI-to-S-Video cable pinouts:

DVI-to-S-Video Cable Pinout Information				
DVI-A Connector Pin	Signal Name	Signal Name	S-Video Connector Pin	Notes:
1	TMDS DATA 2 N			Pin populated in DVI-A connector, but not connected for this cable
2	TMDS DATA 2 P			Pin populated in DVI-A connector, but not connected for this cable
3	TMDS SHIELD 2/4			Pin not populated in DVI-A connector
4	TMDS DATA 4 N			Pin not populated in DVI-A connector
5	TMDS DATA 4 P			Pin not populated in DVI-A connector
6	DDC CLOCK			Pin populated in DVI-A connector, but not connected for this cable
7	DDC DATA			Pin populated in DVI-A connector, but not connected for this cable
8	ANALOG VERTICAL SYNC			Pin populated in DVI-A connector, but not connected for this cable
9	TMDS DATA 1 N			Pin not populated in DVI-A connector
10	TMDS DATA 1 P			Pin not populated in DVI-A connector
11	TMDS SHIELD 1/3			Pin not populated in DVI-A connector
12	TMDS DATA 3 N			Pin not populated in DVI-A connector
13	TMDS DATA 3 P			Pin not populated in DVI-A connector
14	+5VDC			Pin populated in DVI-A connector, but not connected for this cable
15	GROUND			Pin populated in DVI-A connector, but not connected for this cable
16	HOT PLUG DETECT			Pin populated in DVI-A connector, but not connected for this cable
17	TMDS DATA 0 N			Pin populated in DVI-A connector, but not connected for this cable
18	TMDS DATA 0 P			Pin populated in DVI-A connector, but not connected for this cable
19	TMDS SHIELD 0/5			Pin not populated in DVI-A connector

DVI-to-S-Video Cable Pinout Information (Cont.)				
DVI-A Connector Pin	Signal Name	Signal Name	S-Video Connector Pin	Notes:
20	TMDS DATA 5 N			Pin not populated in DVI-A connector
21	TMDS DATA 5 P			Pin not populated in DVI-A connector
22	TMDS CLOCK SHIELD			Pin not populated in DVI-A connector
23	TMDS CLOCK P			Pin populated in DVI-A connector, but not connected for this cable
24	TMDS CLOCK N			Pin populated in DVI-A connector, but not connected for this cable
C1	C1 ANALOG RED			Pin populated in DVI-A connector, but not connected for this cable
C2	C2 ANALOG GREEN	Luminance (Y) Signal (center conductor)	3	
C3	C3 ANALOG BLUE	Chrominance (C) Signal (center conductor)	4	
C4	C4 ANALOG HSYNC			Pin populated in DVI-A connector, but not connected for this cable
C5	C5 ANALOG GROUND	Y, C Returns (shields)	1, 2	
BACKSHELL	SHIELD			Pin populated in DVI-A connector, but not connected for this cable

DVI-A Male to HD15 (VGA) Male Adapter

Cable to be composed of the following:

- Three 75ohm 28 AWG mini-coax cables for the Red, Green, and Blue signals and returns
- Seven UL1589 (28AWG) for VSYNC, HSYNC, DDC_CLK, DDC_DATA, Hot_Plug_Detect, +5VDC, and GROUND
- The above bundles jacketed together in aluminum foil shield and 85% (minimum) braid
- EMI shield metal can on both DVI and HD15 connectors and connected to braid

NOTE: This cable type corresponds to the CC-DVIM-VGAF DVI-to-VGA adapter (FG10-2170-13), available from AMX.

DVI-to-VGA Cable Pinout Information

The following table lists the DVI-to-VGA cable pinouts:

DVI-to-VGA Cable Pinout Information				
DVI-A Connector Pin	Signal Name	Signal Name	HD15 (VGA) Pin	Notes:
1	TMDS DATA 2 N			Pin populated in DVI-A connector, but not connected for this cable
2	TMDS DATA 2 P			Pin populated in DVI-A connector, but not connected for this cable
3	TMDS SHIELD 2/4			Pin not populated in DVI-A connector
4	TMDS DATA 4 N			Pin not populated in DVI-A connector
5	TMDS DATA 4 P			Pin not populated in DVI-A connector
6	DDC CLOCK	DDC CLOCK	15	28AWG
7	DDC DATA	DDC DATA	12	28AWG
8	ANALOG VERTICAL SYNC	VSYNC Signal	14	28AWG
9	TMDS DATA 1 N			Pin not populated in DVI-A connector
10	TMDS DATA 1 P			Pin not populated in DVI-A connector
11	TMDS SHIELD 1/3			Pin not populated in DVI-A connector
12	TMDS DATA 3 N			Pin not populated in DVI-A connector
13	TMDS DATA 3 P			Pin not populated in DVI-A connector
14	+5VDC	+5VDC	9	28AWG
15	GROUND	GND, HS Return	5	28AWG

DVI-to-VGA Cable Pinout Information (Cont.)				
DVI-A Connector Pin	Signal Name	Signal Name	HD15 (VGA) Pin	Notes:
16	HOT PLUG DETECT	+5VDC	9	28AWG
17	TMDS DATA 0 N			Pin populated in DVI-A connector, but not connected for this cable
18	TMDS DATA 0 P			Pin populated in DVI-A connector, but not connected for this cable
19	TMDS SHIELD 0/5			Pin not populated in DVI-A connector
20	TMDS DATA 5 N			Pin not populated in DVI-A connector
21	TMDS DATA 5 P			Pin not populated in DVI-A connector
22	TMDS CLOCK SHIELD			Pin not populated in DVI-A connector
23	TMDS CLOCK P			Pin populated in DVI-A connector, but not connected for this cable
24	TMDS CLOCK N			Pin populated in DVI-A connector, but not connected for this cable
C1	C1 ANALOG RED	RED Coax Signal	1	Red mini-coax signal
C2	C2 ANALOG GREEN	GREEN Coax Signal	2	Green mini-coax signal
C3	C3 ANALOG BLUE	BLUE Coax Signal	3	Blue mini-coax signal
C4	C4 ANALOG HSYNC	HSYNC Signal	13	28AWG
C5	C5 ANALOG GROUND	RGB Coax, VSync/DDC Returns	6, 7, 8, 10, 11	Red, Green, Blue mini-coax returns; VSync/DDC return; NC used as GND
BACKSHELL	Braided Shield	Braided Shield	BACKSHELL	Outer braid, tied to 6, 7, 8, 10, 11

HDMI Male to DVI-D Male Cable

This section details the wiring for HDMI to DVI cabling.

HDMI-to-DVI-D Cable Pinout Information

The following table lists the HDMI-to-DVI-D cable pinouts:

HDMI-to-DVI-D Cable Pinout Information				
HDMI Connector Pin	Signal Name	Wire	DVI-D Pin	Notes:
1	TMDS Data 2+	A	2	
2	TMDS Data Shield	B	3	
3	TMDS Data 2-	A	1	
4	TMDS Data 1+	A	10	
5	TMDS Data Shield	B	11	
6	TMDS Data 1-	A	9	
7	TMDS Data 0+	A	18	
8	TMDS Data 0 Shield	B	19	
9	TMDS Data 0-	A	17	
10	TMDS Clock+	A	23	
11	TMDS Clock Shield	B	22	
12	TMDS Clock-	A	24	
13	CEC	N.C.	N.C.	
14	Reserved	N.C.	N.C.	
15	SCL	C	6	
16	SDA	C	7	
17	DDC/CEC Ground	D	14	
18	+5V Power	5V	16	
19	Hot Plug Detect	C	15	

Audio/Video Configuration

Overview

You can access the configuration settings for the DVX by using one of the following methods:

- Using the front panel buttons
- Using a Web browser

Using the Front Panel Buttons

You can access the configuration settings for the All-In-One Presentation Switcher by using the VIDEO MENU, AUDIO MENU, SWITCH, and STATUS buttons on the front panel of the DVX. Pressing any button opens its respective menu on the LCD display on the front panel. FIG. 65 shows the LCD display. The LCD backlight on the display turns off after 35 seconds of inactivity.

FIG. 65 displays the front panel LCD.



FIG. 65 LCD display

Press the TAKE pushbutton to implement an audio/video switch while you are in the Switch menu on the LCD display. If you are in any menu other than Switch, press the button to cycle through audio and/or video inputs.

Use the Navigational buttons to traverse the available configuration parameters and change their settings. FIG. 66 displays the navigational function of each button.

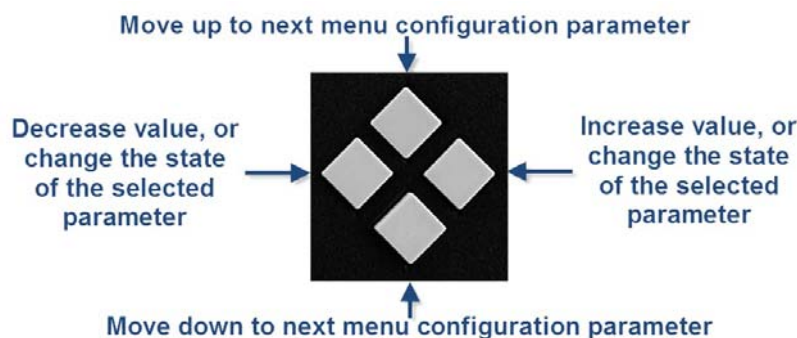

FIG. 66 Navigation buttons

Video Settings

The following table lists the Video Output menu options available by pressing the VIDEO MENU button.

Video Output Menu Options	
Output Select	Use the left and right navigational buttons to manually select which video output you want to use. You can choose from 1, 2, 3, 4, or ALL. (1, 2, or ALL on 22xx DVX models.)
Scaling	Use the left and right navigational buttons to toggle whether you want to scale the output image. You can choose from AUTO, MANUAL, and BYPASS. The default setting is AUTO.
Resolution	Use the left and right navigational buttons to manually select the desired resolution and refresh rate of the selected output. For a complete list of output resolutions, see the <i>DVI and HDMI Supported Output Resolutions</i> section on page 116. Changing the output resolution automatically switches the scaling mode to MANUAL.
AR	Use the left and right navigation buttons to select how video inputs should be displayed when the input and output aspect ratio do not match. You can choose from the following options: <ul style="list-style-type: none"> • MAINTAIN: Maintains the input aspect ratio while filling the screen either vertically or horizontally. Black bars may appear above and below or to the left and right of the image. • STRETCH: Ignores the input aspect ratio and stretches the image to fill the screen in all directions. • ZOOM: Maintains the input aspect ratio while zooming the image to fill the screen in all directions. Image data may be lost on the top and bottom or to the left and right of the displayed image. • ANAMORPHIC: Use with anamorphic formatted video sources so that images appear correctly on the display. The default setting is STRETCH.

Video Output Menu Options (Cont.)	
Logo/Test	Use the left and right navigational buttons to choose an output test pattern. Select Off to disable the test pattern and view video from the selected source. You can choose from <i>Off</i> , <i>Color Bar</i> , <i>Gray Ramp</i> , <i>SMPTE Bar</i> , <i>HiLoTrak</i> , <i>Pluge</i> , and <i>Cross Hatch</i> . NOTE: <i>If you have uploaded a logo to display on the output, you can also select the logo from this option. Logo images must be 24-bit color bitmap files at least 36x36 pixels in size.</i>
Blank Screen	Use the left and right navigational buttons to select the color of the blank screen on the output. You can choose from <i>Black</i> or <i>Blue</i> . The default setting is <i>Black</i> . NOTE: <i>If you have uploaded a logo to display on the output, you can also select the logo from this option. Logo images must be at least 36x36 pixels in size.</i>
OSD	Use the left and right navigational buttons to toggle whether you want the OSD overlay to be turned on or off. You can choose from <i>Enabled</i> or <i>Disabled</i> . When enabled, the input name and resolution displays in a small box in the upper left-hand corner of the screen whenever you select a new input source. The location of the input name and resolution can be changed using the OSD Position option. The default setting is <i>Disabled</i> .
OSD Pos	Use the left and right navigational buttons to select the on-screen display's relative position so it is unobtrusive to video. You can choose from <i>Top Left</i> , <i>Top Right</i> , <i>Bottom Left</i> , and <i>Bottom Right</i> . The default setting is <i>Top Left</i> .
OSD Color	Use the left and right navigational buttons to select the background color for the on-screen display. You can choose from <i>Black</i> , <i>White</i> , <i>Yellow</i> , or <i>Blue</i> . The default setting is <i>Black</i> .
Source (Output Video Adjust):	
Brightness	Use the left and right navigational buttons to alter the brightness level adjustment applied to the selected output. You can set the brightness level from 0-100. The default setting is 50.
Contrast	Use the left and right navigational buttons to alter the contrast level adjustment applied to the selected output. You can set the contrast level from 0-100. The default setting is 50.
H Size	Use the left and right navigational buttons to set the horizontal size of the image for the selected output. You can set the size from 25 to 800. The default setting is 100.
H Shift	Use the left and right navigational buttons to move the location of the video output from left to right. You can set the shift from -127 to 127. The default setting is 0.
V Size	Use the left and right navigational buttons to set the vertical size of the image for the selected output. You can set the size from 25 to 800. The default setting is 100.
V Shift	Use the left and right navigational buttons to move the location of the video output up and down. You can set the shift from -127 to 127. The default setting is 0.
Zoom	Use the left and right navigational buttons to set the zoom on the video output image. Adjusting the zoom also adjusts the horizontal and vertical sizes of the video output. You can set the zoom from 25 to 800. The default setting is 100.
Freeze	Use the left and right navigational buttons to toggle whether you want the current image to freeze and remain on the screen. You can choose from <i>On</i> or <i>Off</i> . The default setting is <i>Off</i> .
Revert to Default	Use the left and right navigational buttons to indicate that you want to return all video options to their default settings. When the display indicates to "Press TAKE for YES", pressing the Take button reverts all configurable output image adjustments to their default values.

The following table lists the Video Input menu options available by pressing the VIDEO MENU button twice from the main volume screen.

Video Input Menu Options	
Input Select	Use the left and right navigational buttons to manually select which video input you want to use. You can choose any available input from 1-10. (1-6 on 22xx DVX models.)
Status	Use this option to view the status of the selected input. The status can read <i>NO SIGNAL</i> , <i>SIGNAL OK</i> , and <i>UNKNOWN</i> . This is a read-only field and pressing the left/right arrow keys will have no effect.
Type	Use the left and right navigational buttons to indicate the video format of the selected input. For Multi-Format inputs, you can choose from <i>HDMI</i> , <i>DVI</i> , <i>VGA</i> , <i>Component</i> , <i>S-Video</i> , and <i>Composite</i> . The default setting is <i>Component</i> . For HDMI inputs, you can choose from <i>HDMI</i> or <i>DVI</i> .
Auto Res	Use the left and right navigational buttons to toggle whether you want the video input resolution to be set automatically. The default setting is <i>ON</i> .
Resolution	Use the left and right navigational buttons to manually select the correct resolution and refresh rate of the selected output. For a complete list of output resolutions, see the <i>DVI and HDMI Supported Output Resolutions</i> section on page 116. Changing the input resolution will automatically switch the scaling mode to <i>MANUAL</i> .
EDID	Use the left and right navigational buttons to indicate the type of EDID data to be sent to the source or which output's EDID you would like to mirror to that source. You can choose <i>All resolutions</i> , <i>Wide-Screen resolutions</i> , <i>Full-Screen resolutions</i> , or to mirror the EDID from any of the HDMI outputs.

Video Input Menu Options (Cont.)	
EDID Update	When the EDID is set to mirror one of the outputs, use the left and right navigational buttons to indicate whether you want the EDID going to the source to update anytime the output EDID changes or only when an update is requested manually. You can choose from AUTO and OFF. The default setting is AUTO.
Source (Input Video Adjust):	
NOTE: <i>The following input video adjustments have no effect on the display of the internally generated test patterns. Refer to the Supported Video Settings table on page 36 for details on which settings apply to each input format type.</i>	
Black & White	Use the left and right navigational buttons to toggle whether you want the video from the selected input to display in black and white. You can set the Black & White option to On or Off. The default setting is Off. This option is useful when displaying black & white content on a color document camera.
Brightness	Use the left and right navigational buttons to alter the brightness level adjustment applied to the selected input. You can set the brightness level from 0-100. The default setting is 50.
Contrast	Use the left and right navigational buttons to alter the contrast level adjustment applied to the selected input. You can set the contrast level from 0-100. The default setting is 50.
Saturation	Use the left and right navigational buttons to alter the saturation level adjustment applied to the selected input. You can set the saturation level from 0-100. The default setting is 50.
Hue	Use the left and right navigational buttons to alter the hue adjustment applied to the selected input. You can set the hue level from 0-100. The default setting is 50.
Phase	Use the left and right navigational buttons to alter the phase adjustment for the selected input. This option is only available for RGB inputs. You can set the phase adjustment from 0-32. The default setting is 0.
H Shift	Use the left and right navigational buttons to shift the location of the video input from left to right. This option is only available for RGB inputs. You can set the shift from -50 to 50. The default setting is 0.
V Shift	Use the left and right navigational buttons to shift the location of the video input up and down. This option is only available for RGB inputs. You can set the shift from -10 to 10. The default setting is 0.
Revert to Default	Use the left and right navigational buttons to indicate that you want to return all video options to their default settings.

Setting the Video Type for a Video Input

Each video input type must be set manually. Perform these steps to set the video type for a video input:

1. Press the **VIDEO MENU** button on the front panel of the DVX two times to open the Video Input menu.
2. Press the left and right navigation buttons to select the input to change.
3. Press the down navigational button until the Type option appears.
4. Use the left and right navigational buttons to select the video format for the selected input.

Changing the Video Output Resolution

Perform these steps to change the video output resolution:

1. Press the **VIDEO MENU** button on the front panel of the DVX to open the Video Output menu.
2. Press the left and right navigation buttons to select the output to change.
3. Press the down navigational button until the Resolution option appears.
4. Use the left and right navigational buttons to locate the appropriate output resolution and refresh rate. You can also choose Auto to automatically detect the resolution and refresh rate.

Changing the Output Aspect Ratio

Perform these steps to change the output aspect ratio:

1. Press the **VIDEO MENU** button on the front panel of the DVX to open the Video Output menu.
2. Press the left and right navigation buttons to select the output to change.
3. Press the down navigational button until the Aspect Ratio option appears.
4. Use the left and right navigational buttons to locate the appropriate aspect ratio.

Selecting a Video Test Pattern

Selecting a test pattern for your input source can help determine if the displays are connected correctly. Perform these steps to select a test pattern:

1. Press the **VIDEO MENU** button on the front panel of the DVX to open the Video Output menu.
2. Press the left and right navigation buttons to select the output on which to display the test pattern.
3. Press the down navigational button until the Logo/Test option appears.
4. Use the left and right navigational buttons to select the appropriate output test pattern.

Audio Settings

The following tables list the audio options available on the LCD display by pressing the AUDIO MENU button on the front panel:

Audio Output Menu Options	
Audio Output Select	Use the left and right navigational buttons to manually select which video output you want to use. You can choose from 1, 2, 3, 4, or ALL. (1, 2, 3, or ALL on 22xx DVX models.)
Volume	Use the left and right navigational buttons to set the volume of the selected audio output. You can set the volume from 0 to 100. The default setting is 20.
EQ Preset	Use the left and right navigational buttons to select a group of preset equalizer settings. You can choose from <i>Voice</i> , <i>Movie</i> , <i>Music</i> , and <i>Off</i> .
Balance	Use the left and right navigational buttons to adjust the balance level of the selected audio output. You can set the balance level from -20 to +20. The default value is 0.
Format	Use the left and right navigational buttons to change the audio format of the selected audio input. You can set the audio format to Stereo or Mono. The default setting is Stereo.
Track Output 1	Use the left and right navigational buttons to indicate whether you want to activate amp volume tracking on the selected audio output. This option tracks the amp volume for Output 1 and is only available on ports 2-4. You can choose from <i>Off</i> or <i>On</i> .
SRC Mix	Use the left and right navigational buttons to set the mix level of the audio input source in the overall mix. You can set the mix level from 0 to -100. The default setting is 0.
Mic1 Mix	Use the left and right navigational buttons to set the mix level of microphone 1 in the overall mix. You can set the mix level from 0 to -100. The default setting is 0.
Mic2 Mix	Use the left and right navigational buttons to set the mix level of microphone 2 in the overall mix. You can set the mix level from 0 to -100. The default setting is 0.
HDMI	Use the left and right navigational buttons to indicate which analog audio output to embed in the selected HDMI output. You can choose from <i>Out1</i> , <i>Out2</i> , <i>Out3</i> , <i>Out4</i> , <i>Pass-thru</i> , and <i>Off</i> .
HDMI EQ	Use the left and right navigational buttons to toggle whether the equalizer settings for the selected analog output should be applied to the HDMI output. You can choose from <i>On</i> or <i>Off</i> . The default value is <i>Off</i> .
SPDIF	Use the left and right navigational buttons to indicate the audio stream to output through the S/PDIF output. You can choose from any of the available audio outputs including the audio on the HDMI outputs.
Max Volume	Use the left and right navigational buttons to adjust the maximum volume of the audio output. You can set the maximum volume from 0 to 100 in increments of 1. The default value is 100.
Min Volume	Use the left and right navigational buttons to adjust the minimum volume of the audio output. You can set the minimum volume from 0 to 100 in increments of 1. The default value is 0.
Delay (ms)	Use the left and right navigational buttons to set the number of milliseconds to delay the audio. The default value is 32.
Test Tone	Use the left and right navigational buttons to select an internally generated audible tone. The selected tone overrides any input source selection. Selecting 'Off' removes the override, allowing you to hear audio from the selected source. You can choose from <i>Off</i> , <i>60Hz</i> , <i>250Hz</i> , <i>400Hz</i> , <i>1kHz</i> , <i>3kHz</i> , <i>5kHz</i> , <i>10kHz</i> , <i>Pink Noise</i> , and <i>White Noise</i> .
Ducking	Use the left and right navigational buttons to set the ducking level of the audio output. You can choose from <i>Off</i> , <i>Low</i> , <i>Med</i> , <i>High</i> , and <i>Custom</i> . All detailed parameter adjustments for the Custom setting can be made from the web user interface. See the <i>Using a Web Browser</i> section on page 63 for more information. The default setting is <i>Off</i> .
Mic Threshold	Use the left and right navigational buttons to set the threshold of the ducker for microphone 1. You can set the threshold level from 0 to -60.
Mic Priority	Use the left and right navigational buttons to indicate whether Mic 1 has priority over Mic 2. You can choose from <i>None</i> or <i>Mic1</i> .
Revert to Default	Use the left and right navigational buttons to indicate that you want to return all audio output options to their default settings.

Audio Input Menu Options	
Audio Input Select	Use the left and right navigational buttons to manually select which video input you want to use. You can choose from any of the available audio inputs.
Gain	Use the left and right navigational buttons to adjust the gain/attention level of the audio input. You can set the gain from -24 to +24dB in 1dB increments. The default setting is 0.
Format	Use the left and right navigational buttons to toggle the analog format for the audio input. You can choose from <i>Stereo</i> or <i>Mono</i> . The default setting is <i>Stereo</i> .
Digital	Use the left and right navigational buttons to a digital format for the selected audio input. You can choose from <i>PCM 2-Channel</i> , <i>PCM Multi-Channel</i> , <i>AC-3 (Dolby)</i> , <i>AC-3 + DTS</i> , <i>AC-3 + MPEG</i> , <i>AC-3 + AAC</i> , <i>Dolby TrueHD</i> , or <i>DTS HD Master</i> .
Compression	Use the left and right navigational buttons to adjust the compression level of the selected audio input. You can choose from <i>Off</i> , <i>Low</i> , <i>Medium</i> , <i>High</i> , and <i>Custom</i> . The default value is <i>Off</i> .
Revert to Default	Use the left and right navigational buttons to indicate that you want to return all audio input options to their default settings.

Microphone Settings

The following table lists the microphone options available on the LCD display by pressing the AUDIO MENU button on the front panel:

Mic Input Menu Options	
Mic Input Mode	Use the left and right navigational buttons to manually select Single Stereo to adjust both microphone inputs or Dual Mono Mode to adjust the microphone settings individually. If you select Dual Mono Mode, be sure to select the desired microphone from the Mic Input Select option before adjusting the available settings for the microphone.
Mic Input Select	Use the left and right navigational buttons to manually select which microphone input you want to use. When in Dual Mode, you can choose from 1 or 2.
Enable	Use the left and right navigational buttons to toggle whether the selected microphone is active. You can choose from <i>Off</i> or <i>On</i> . The default setting is <i>Off</i> .
Preamp Gain	Use the left and right navigational buttons to adjust the preamp gain level of the microphone input. You can set the gain from 0 to +65dB in 1dB increments. The default setting is 0.
Gain	Use the left and right navigational buttons to adjust the gain/attention level of the microphone input. You can set the gain from -24 to +24dB in 1dB increments. The default setting is 0.
Compression	Use the left and right navigational buttons to adjust the compression level of the selected microphone. You can choose from <i>Off</i> , <i>Low</i> , <i>Medium</i> , <i>High</i> , and <i>Custom</i> . The default value is <i>Off</i> .
Limiter	Use the left and right navigational buttons to adjust the limiter function which suppresses loud noise bursts from dropping the mic and helps avoid feedback noise. You can choose from <i>Off</i> , <i>Low</i> , <i>Medium</i> , <i>High</i> , and <i>Custom</i> . The default setting is <i>Off</i> .
Gating	Use the left and right navigational buttons to adjust the noise gate which filters background noise. You can choose from <i>Off</i> , <i>Low</i> , <i>Medium</i> , <i>High</i> , and <i>Custom</i> . The default setting is <i>Off</i> .
Phantom Power	Use the left and right navigational buttons to turn on or turn off phantom power for the selected microphone. You can set the Phantom Power to <i>On</i> or <i>Off</i> . The default setting is <i>Off</i> .
Revert to Default	Use the left and right navigational buttons to indicate that you want to return all microphone options to their default settings.

Selecting an Audio Test Tone

Selecting a test tone for your input source can help determine if you have your audio devices connected correctly. Perform these steps to select a test tone:

1. Press the **AUDIO MENU** button on the front panel of the DVX.
2. Press the left and right navigation buttons to select the output on which to play the test tone (ALL, 1, 2, 3, or 4).
3. Press the down navigational button until the Test Tone option appears.
4. Use the left and right navigational buttons to select an appropriate audio test tone.

Switch Menu

Press the SWITCH button to access the Switch menu for switching between the available audio and video devices. Use the UP and DOWN navigational buttons to scroll through the menu options. Use the RIGHT and LEFT navigational buttons to selected the desired input and output. Press the TAKE button to execute the switch.

Switch Menu	
Switch Level	Use the SWITCH button to indicate whether you want to switch the Video, Audio or Both. The subsequent options in this menu depend on your choice with this option (see below).
Select A+V Input	Use the SWITCH button to cycle through the available inputs. This option is only available if you select Both on the Switch Level option.
Select A+V Output	Use the SWITCH button to cycle through the available outputs. This option is only available if you select Both on the Switch Level option.
Select Video Input	Use the SWITCH button to cycle through the available video inputs. This option is only available if you select Video on the Switch Level option.
Select Video Output	Use the SWITCH button to cycle through the available video outputs. This option is only available if you select Video on the Switch Level option.
Select Audio Input	Use the SWITCH button to cycle through the available audio inputs. This option is only available if you select Audio on the Switch Level option.
Select Audio Output	Use the SWITCH button to cycle through the available audio outputs. This option is only available if you select Audio on the Switch Level option.

Status Menu

Press the STATUS button to access the Status menu and display system information on the LCD display. Use the UP and DOWN navigational buttons to scroll through the menu options. These options are view-only.

Status Menu	
Vid Status	Displays which video input is associated with each output.
Aud Status	Displays which audio input is associated with each output.
Mic Status	Displays the active status of each microphone output.
System Number:	Displays the system number of the All-In-One Presentation Switcher.
Serial Number:	Displays the serial number of the All-In-One Presentation Switcher.
MAC Address:	Displays the MAC address of the All-In-One Presentation Switcher.
IP Address:	Displays the IP address of the network.
IP Address Type:	Displays whether the IP address is static or DHCP.
Subnet Mask:	Displays the subnet mask of the network.
Gateway:	Displays the gateway address of the network.
Hostname:	Displays the hostname of the device.
DNS Address:	Displays the IP or DNS address of the device.
Master Version:	Displays the version number of the firmware the Master is using.
Switcher Version:	Displays the version number of the firmware the switcher is using.
Device Version:	Displays the version number of the firmware the device is using.
Fan:	Displays the speed in Revolutions per Minute (RPM) for each fan.
Temperature:	Displays the temperature of the device in degrees Celsius (C).
Enter Standby Mode:	Use the left and right buttons to toggle whether Standby Mode is active. Select either Off or On. The default setting is Off.

DVX WebConsole

The DVX features an on-board WebConsole that allows you to configure the device and make various adjustments to audio/video and system settings. The WebConsole is accessed via a web browser on a PC that has network access to the DVX.

The DVX WebConsole can be divided into two primary parts:

- Audio/Video Switcher Configuration Settings
- Master Controller Configuration Options

Accessing the WebConsole

From any PC that has access to the LAN that the target Master resides on:

1. Open a web browser and type the IP Address of the target Master in the Address Bar.
2. Press Enter to access WebConsole for that Master. The initial view is the Web Control page (FIG. 67).

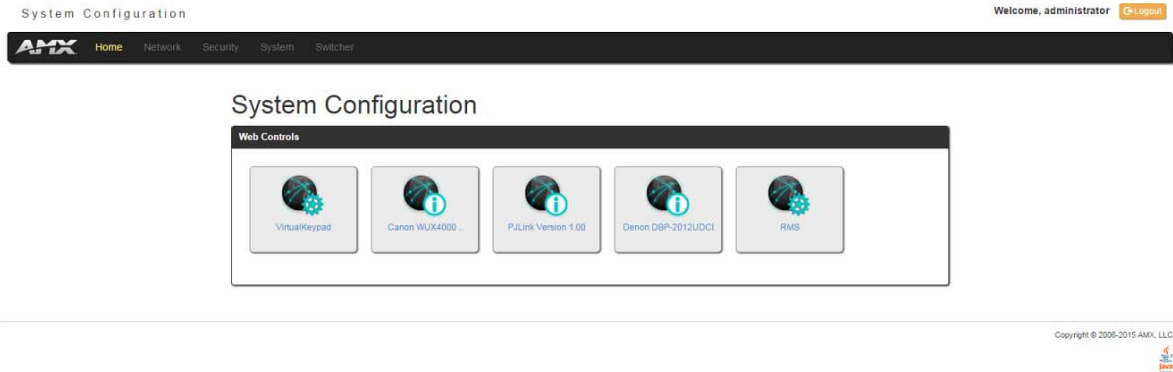

FIG. 67 WebConsole - WebControl Page (initial view)

When using the Microsoft Internet Explorer browser in Windows 8, you may not be able to login and connect to the Master via the WebConsole. If you cannot login and connect, try any of the following options:

- Shift+Right-click Internet Explorer icon and select Run as administrator.
- Select Internet Options | Advanced | Security Settings, and check Enable Enhanced Protection Mode. A Windows 8 restart will be required.
- Use the Master's Hostname instead of its IP numeric address to enter the URL (e.g.: <http://AMXM98A1A2B> rather than <http://192.168.1.123>).
- Use a non-Windows 8 device if Internet Explorer 10+ is required.

Master Controller Configuration Options

The 3200-series DVXs feature a NetLinX central controller functionally equivalent to an NX-3200. The 2200-series DVXs feature a NetLinX central controller equivalent to an NX-2200. The DVX provides the same set of configuration pages that are available to the NX-series controllers.

NOTE: All NX-Series NetLinX Masters share a common WebConsole, as described in the *NetLinX Integrated Controllers WebConsole & Programming Guide* (available at www.amx.com).

WebConsole - System Configuration

The DVX (and all other NetLinX Masters) features a built-in WebConsole that allows you to make various configuration settings via a web browser on any PC that has access to the Master.

The webconsole consists of a series of web pages that are collectively called the "Master Configuration Manager" (FIG. 67).

The webconsole is divided into three primary sections, indicated by three control buttons across the top of the main page (FIG. 68):

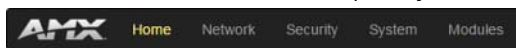

FIG. 68 System Configuration Menu Options

- **Home:** This option appears when you access the System Configuration page. Use these options to view any connected device or access a module.
- **Network:** Click to access the Network Settings for the Master. The options on these pages enable you to view and modify the IPv4 and IPv6 network settings and the clock settings for the system.
- **Security:** Click to access the System Security page. The options in this page allow you to configure various aspects of NetLinX System and Security on the Master, including network configuration and creating users and roles.
- **System:** Click to access the System Details page. The options on this page allow you to view and configure various aspects of the NetLinX System.
- **Modules:** Click to access several different device-related pages.
- **Switcher:** Click to access the Enova Switcher Configuration page.

WebConsole User Interface - Additional Documentation

For a full description of all System Configuration pages, refer to the *NX-Series Controllers WebConsole & Programming Guide*, available at www.amx.com.

Using a Web Browser

You can access the configuration settings for the All-In-One Presentation Switcher by using the latest, industry-accepted version of HTML5 web browsers. If a browser is inconsistent, upgrade or try a different browser. The system configuration pages are available by entering the IP address of the NetLinX master into the location bar of your web browser. Entering your IP address into your web browser opens the Main WebControl page (FIG. 69).

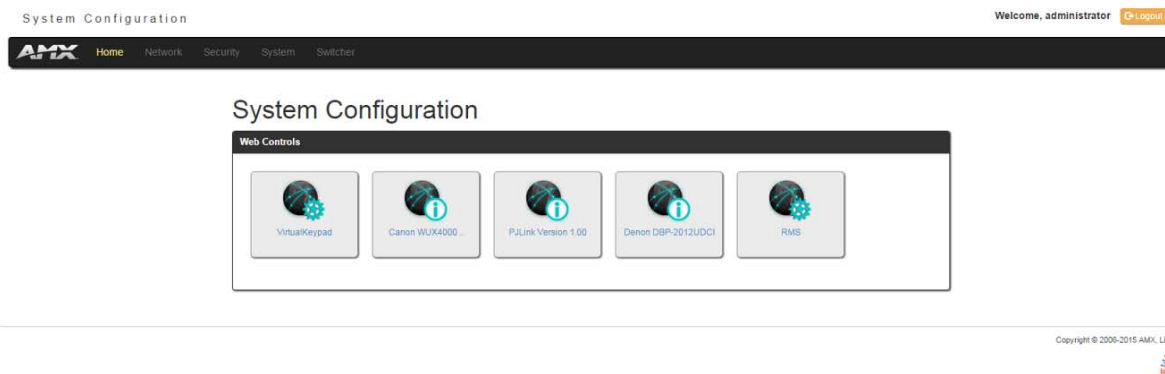

FIG. 69 Main WebControl page

Perform these steps to access the configuration settings:

1. Open a web browser.
2. Enter the IP address of the All-In-One Presentation Switcher in the location bar of the web browser. (If you do not know your switcher's IP address, see the *Locating the IP Address of the DVX* section on page 64.) The Main WebControl page opens (FIG. 69).

NOTE: WebControl requires that you install the latest version of the Adobe Flash Player plug-in for your browser. If your browser does not have the Flash Player plug-in installed, you will be prompted to install it.

3. Click the Switcher tab to open the Enova DVX Setup page (FIG. 70).

If a web browser or Flash Player is not available, the All-In-One Presentation Switcher's front panel and NetLinX commands provide equivalent controls for audio/video configuration. See the *Using the Front Panel Buttons* section on page 56 for more information.

Locating the IP Address of the DVX

You can locate the IP address of the DVX by using the buttons on the front panel of the unit. The IP address appears on the LCD display on the front panel of the DVX. Perform these steps to locate the IP address of the unit:

1. Press the **STATUS** button on the front panel of the unit. The Status menu appears on the LCD display.
2. Use the **UP** and **DOWN** navigational arrow buttons to navigate through the options until you locate the All-In-One Presentation Switcher's IP address. Note the IP address for future reference.

NOTE: You can use the Status Menu to verify current TCP/IP settings using the UP and DOWN navigational buttons.

Default User Names and Passwords

The following table lists the default user names and passwords for accessing the DVX through NetLinx Studio or the WebConsole.

Default User Names and Passwords		
	User Name	Password
NetLinx Studio	netlinx	password
WebConsole	administrator	password

General Options

The WebConsole Configuration page contains settings that are accessible from each tab. FIG. 70 indicates the universally accessible options available on the web pages.

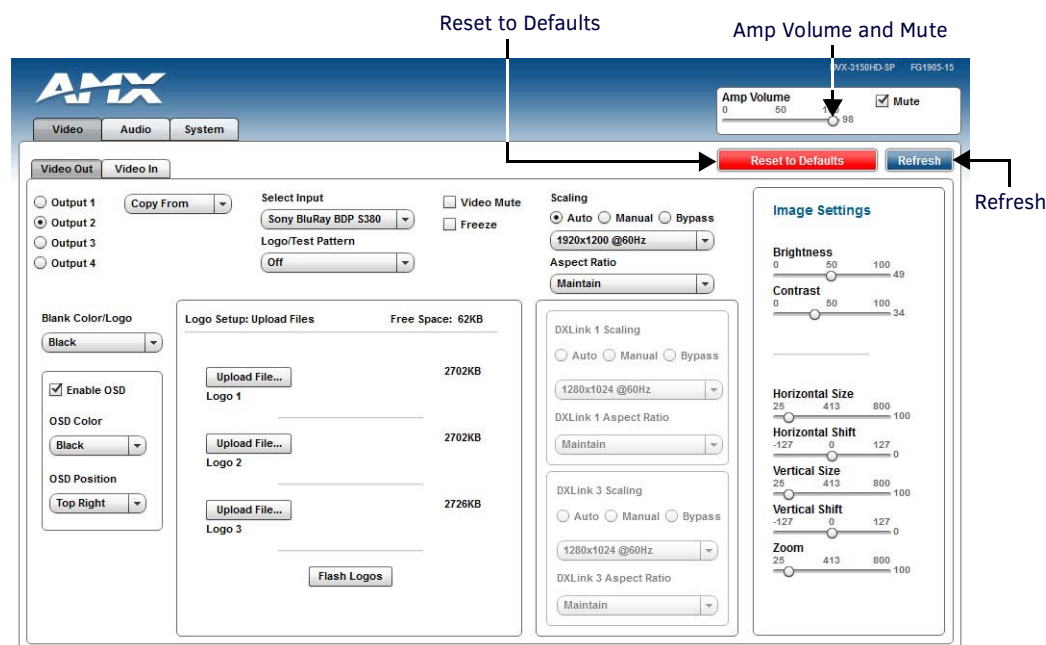

FIG. 70 WebConsole Configuration page

The following table lists the general options for the WebConsole Configuration page:

General Options	
Mute	Turns off the audio for the device.
Amp Volume	Sets the output volume.
Refresh	Click to reload all settings.
Reset to Defaults	Click to reset the current page's settings to its factory default.

Video Settings

The Video Out tab enables you to set the resolution, aspect ratio, and picture qualities of each individual video input. Any changes you make reflect instantaneously on your source input and output devices.

Video Out

FIG. 71 displays the Video Out page for the DVX.

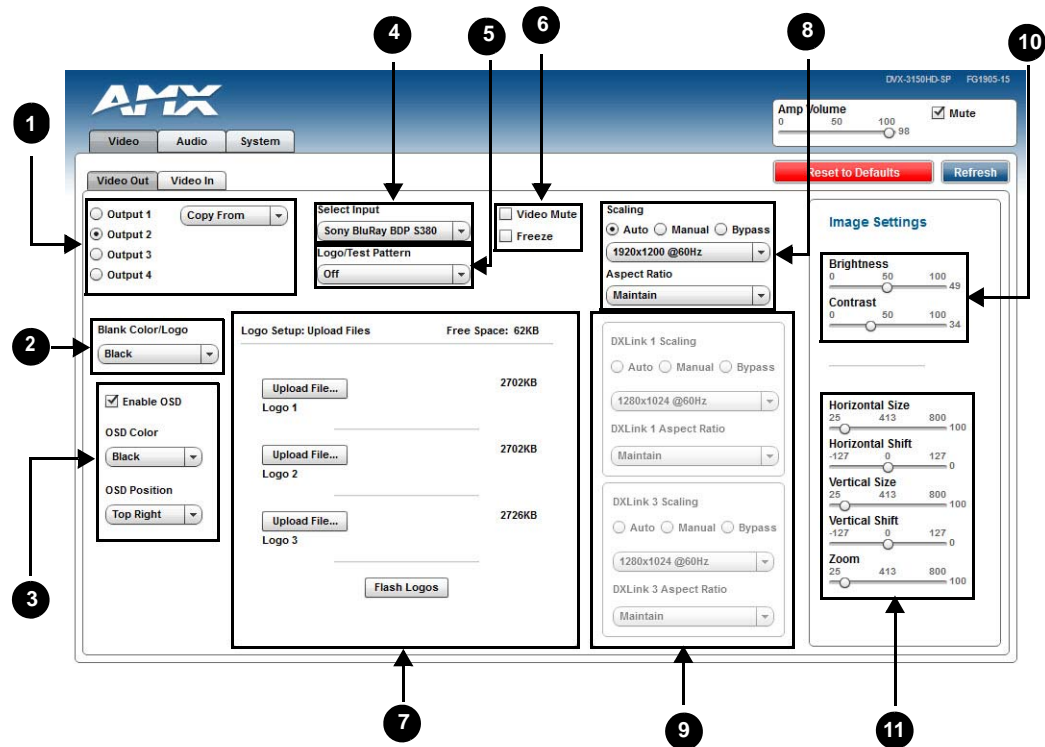

FIG. 71 WebConsole Configuration page - Video Out tab

1 - **Output Select:** Select the corresponding option button to select the video output to adjust. When you select an output, the other options on the page change to reflect the output's current settings. You can copy the settings from one output to the selected output by using the Copy From menu.

NOTE: If you have a Virtual device using the same port (5002) as the DVX, all notifications are routed to virtual device rather than the DVX. In this case, initial states for the video outputs will not be represented in the Web Console. When possible, avoid using virtual devices on the same port as the DVX.

2 - **Blank Color/Logo:** Use the drop-down menu to select the color of the blank screen on the output. If you have uploaded a logo to display on the output, you can also select the logo from this menu.

3 - **OSD:** This area allows you to activate the on-screen display. When enabled, the input name and resolution displays in a small box in a corner of the screen whenever you select a new input source. From the available menus in the same area, you can select the color scheme and location of the OSD.

4 - **Select Input:** Use the menu to select a video input to be switched to the selected video output.

5 - **Logo/Test Pattern:** Use the menu to choose an image logo or output test pattern to display on the video output. Select Off to disable the logo or test pattern and view video from the selected source. You can choose from *Off*, *Color Bar*, *Gray Ramp*, *SMPT E Bar*, *HiLoTrak*, *Pluge*, and *Cross Hatch*. If you have uploaded a logo to display on the output, you can also select the logo from this menu.

6 - **Video Mute:** Click to toggle whether the video is muted (blanked) on the video output.

Freeze: Click the check box to freeze the current image so that it remains on the screen.

7 - **Logo Setup:** The Logo Setup area enables you to load up to three bitmap image files available for display on the video output. Click each Upload File button to locate and upload an image file to the unit's local memory, then click the Flash Logos button to load the image files into memory. Images must be 24-bit color bitmap files at least 36x36 pixels in size. There is 8192kb of flash memory available for storing the three image files. The amount of free space remaining appears on the screen. See the *Uploading an Image File* section on page 66 for more information.

NOTE: Large images can cause a slowdown in performance. Though images up to 1920x1200 are supported, AMX recommends using an image size no greater than 640x480.

8 - **Scaling:** Click Auto to have the unit automatically set the video resolution for the selected output display based on the EDID information received from the connected display device. Click Manual to manually override the video resolution for the output display. After choosing Manual, select a resolution and an aspect ratio from the corresponding menus. Select Bypass to disable scaling and send unscaled video from the selected input to the display.

9 - **DXLink:** This section enables you to establish scaling and aspect ratio settings for the DXLink outputs. If these outputs are not available on your unit, this area appears grayed-out.

10 - **Image Settings:** Use the sliders to set the brightness and contrast for the selected video output.

11 - **Video Adjustments:** Use the sliders to set the horizontal and vertical size and shift and the zoom for the selected video output.

NOTE: *Your video configuration is not affected by a power loss, restarting the unit, or upgrading the firmware.*

Uploading an Image File

You can upload static image files to the DVX and display the logo images on a video output. You can upload up to three images to the unit. There is 8192kb of flash memory available for storing the three image files. The amount of free space remaining appears on the Video Out tab. Images must be 24-bit color bitmap files at least 36x36 pixels in size.

CAUTION: *Large images can cause a slowdown in performance. Though images up to 1920x1200 are supported, AMX recommends using an image size no greater than 640x480.*

Perform these steps to upload an image file:

1. Open a web browser.
2. Enter the IP address of the All-In-One Presentation Switcher in the location bar of the web browser. (If you do not know your switcher's IP address, see the *Locating the IP Address of the DVX* section on page 64.) The Main WebControl page opens (FIG. 69).
3. Use the Device options menu at the top of the screen to select the <DEVICE #> - DVX-xxxxHD-xx Switch Device. (Substitute the model number of your unit for xxxx.) The Configuration page opens in a separate pop-up window (FIG. 71).
4. On the Video Out tab, click Upload File. (You can click any of the three available buttons.)
5. Select an image file from a location accessible to the DVX and click OK.
6. Once the file is uploaded, click Flash Logos to load the images files into memory.

CAUTION: *Using concurrent web browsers or users while uploading or flashing image files can cause corruption in your images. It is a best practice to use only a single web browser when uploading or flashing an image file.*

NOTE: *Closing and restarting your web browser removes all current image file information from the Web Console page. However, if you completed uploading the image, the images are still loaded into the DVX's memory.*

Video In

FIG. 72 displays the Video In tab on the Video page. The Video In tab enables you to set the resolution, aspect ratio, and picture qualities of each individual video input. Any changes you make reflect instantaneously on your source input and output devices.

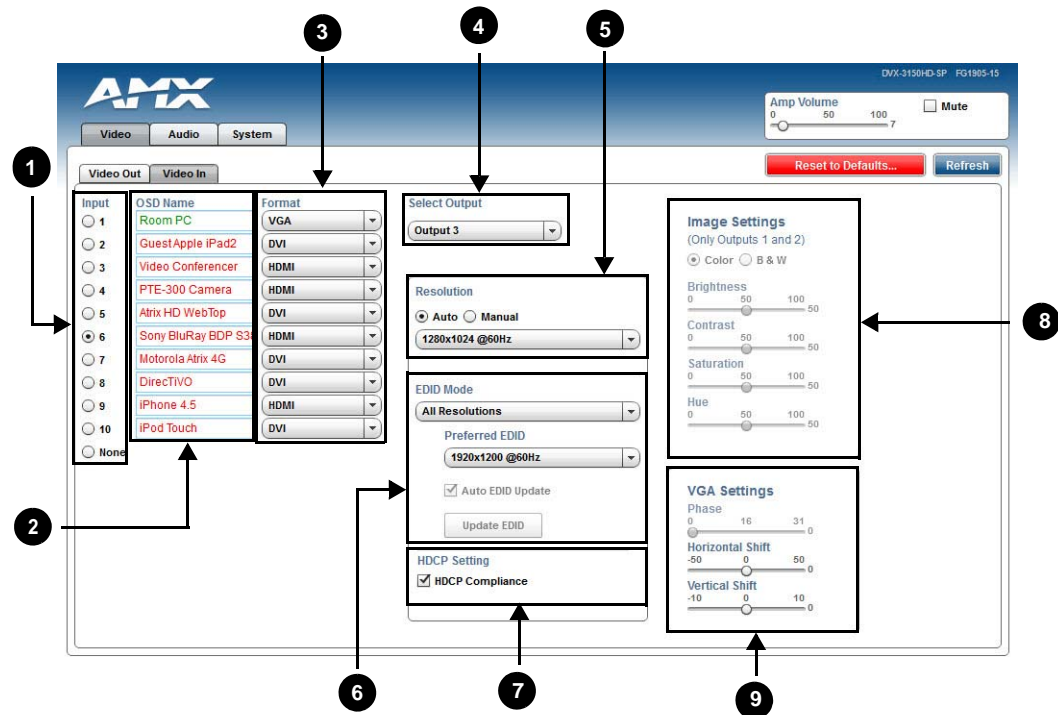

FIG. 72 WebConsole Configuration page - Video In tab

1 - **Input:** Select the corresponding option button to switch that video input to the selected output (see Select Output below). When you select an input, the other options on the page change to reflect the input's current settings. You can only select one video input at a time. Select None to send no signal to the selected output. You can click the Refresh button on the page to update the color coding on the Video Input Select option buttons. Click Refresh after connecting a new input or correcting a resolution on the input so you can be sure it is working.

2 - **OSD Name:** Enter a unique name for the device in the space provided to more easily identify each input. The name you enter here appears in the on-screen display (OSD), if enabled.

The lettering changes color depending on whether video is detected on the selected input. Green indicates a signal is detected, gray indicates a signal is detected but cannot be identified, and red indicates no signal is detected. You can enter up to 63 characters for a single name.

NOTE: Although you can add up to 63 characters, ICSP only retains the first 31 characters. Anything you add beyond the character limit is truncated.

Space characters are valid, however, if they appear at the start of a name, they will be truncated. These fields are optional.

3 - **Format:** Use the drop-down menus to select the video format for each video input. The selection should indicate the type of connection used to connect the video source to the switcher.

For Multi-Format inputs, you can choose from *HDMI*, *DVI*, *VGA*, *Component*, *S-Video*, and *Composite*. The default setting is Component. For HDMI inputs, you can choose from *HDMI* or *DVI*.

4 - **Select Output:** Use the menu to select the video output you want to use.

5 - **Resolution:** Click Auto to have the unit automatically detect the video resolution for the selected input signal, or click Manual to manually select the video resolution for the selected input signal. After clicking the Manual option button, select a resolution from the corresponding drop-down menu. The Auto option is selected by default.

NOTE: The recommended setting is Auto. In Manual mode, the DVX shows blank video if the input is set to any resolution other than the selected manual resolution. See the EDID Mode section below for information on controlling the resolution provided by connected sources.

6 - **EDID Mode:** Use the menus to indicate the desired EDID information to be sent to the selected video source. You can choose from one of the built-in EDID files which includes All Resolutions, only Full Screen Resolutions, or only Wide Screen Resolutions, or you can choose to mirror the EDID received from any connected display. Choosing one of the mirror modes turns off the HDMI Audio control for the selected input.

The Preferred EDID menu is only available if you select one of the internal EDID files (All, Full, or Wide). In this mode you can select the specific preferred resolution to present to the connected source.

The Auto EDID Update check box and the update EDID button are only available if you select to mirror the EDID from a connected display. Select the Auto EDID Update check box if you want the EDID sent to the source to update anytime the EDID received from the connected display changes. De-select this check box to prevent automatically updating the EDID sent to the source and only update the EDID when the Update EDID button is clicked.

7 - **HDCP Setting:** Click the check box to activate HDCP compliance on the selected input. HDCP compliance is active by default.

8 - **Image Settings:** Click the Color or B&W option button to select a color setting for the video input. Use the sliders to alter the brightness, contrast, saturation, and hue for the video input.

9 - **VGA Settings:** Use the sliders to alter the phase, horizontal shift, and vertical shift settings for VGA inputs.

Audio Settings

The Audio page enables you to set the audio qualities for each audio input, microphone input, amplifier output, and line output. Any changes you make reflect instantaneously on your source input and output devices.

Audio Out

FIG. 73 displays the Audio Out page for the DVX.

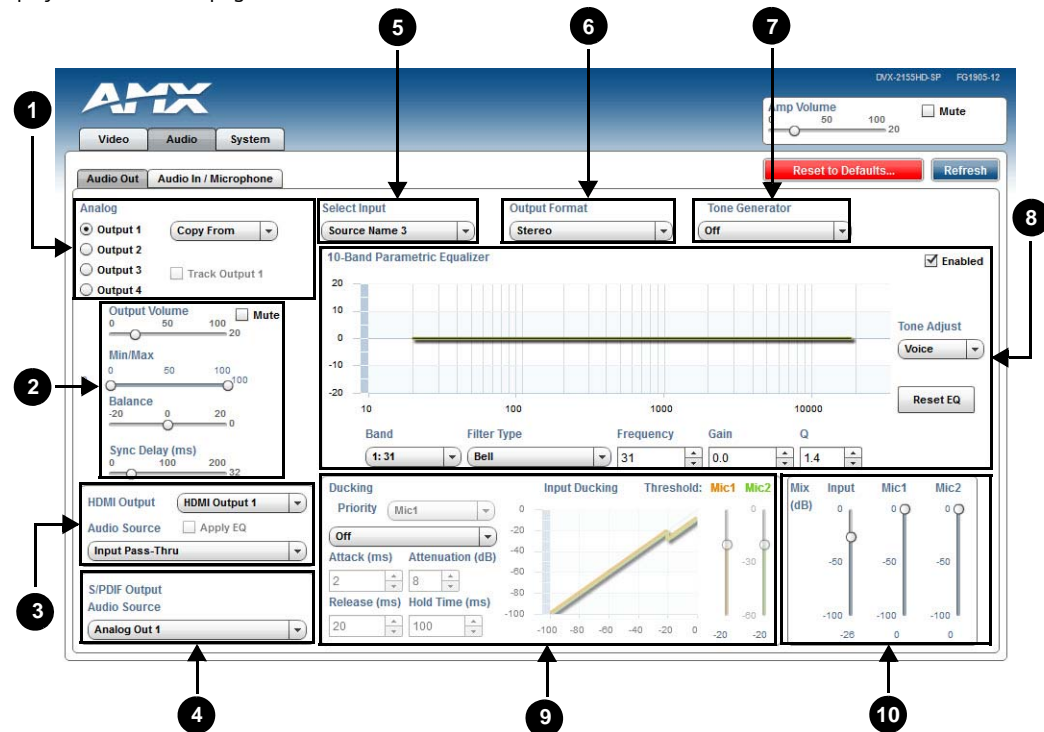

FIG. 73 WebConsole Configuration page - Audio Out tab

1 - **Analog Output:** Select the corresponding option button to select an audio output to adjust. You can only select one audio output at a time. Click the Track Output 1 check box to track the amp volume for Output 1. This option is only available for outputs 2, 3, and 4.

2 - **Output Volume:** Use the sliders to set the output levels for the selected audio output. You can set the following options for each audio output:

Output Volume: Use the slider to set the volume of the selected audio output. You can set the volume from 0 to 100. The default setting is 20.

Min/Max: Use the sliders to adjust the minimum and maximum volume of the audio output. There are separate sliders on this option for minimum and maximum volume. You can set the maximum volume from 0 to 100 in increments of 1. The default value is 100. You can set the minimum volume from 0 to 100 in increments of 1. The default value is 0.

Balance: Use the slider to adjust the balance level of the selected audio output. You can set the balance level from -20 to +20. The default value is 0.

Sync Delay: Use the slider to set the number of milliseconds to delay the audio. The default value is 32.

Additionally, you can silence the audio output by clicking the Mute check box.

3 - **HDMI Output:** Use the available options to configure the HDMI output.

HDMI Output: Select the HDMI output for which you want to adjust the audio options.

Audio Source: Select the audio stream to output through the selected HDMI output. You can choose from Input Pass-thru or any of the four available Analog Outputs.

Apply EQ: Click the check box to toggle whether the volume and equalizer for the HDMI source port is active.

4 - **S/PDIF Output:** Select the audio stream to output through the S/PDIF output. You can choose from any of the available HDMI or Analog Outputs.

5 - **Select Input:** Use the menu to switch the audio input to the selected audio output.

6 - **Output Format:** Use the menu to change the audio format of the selected audio output. You can set the audio format to Stereo or Mono. The default setting is Stereo.

7 - Tone Generator: The tone generator provides an internally generated audible tone. The selected tone overrides any input source selection. Selecting 'Off' removes the override, allowing you to hear audio from the selected source. You can choose from Off, 60Hz, 250Hz, 400Hz, 1kHz, 3kHz, 5kHz, 10kHz, Pink Noise, and White Noise.

8 - Equalizer: The equalizer is a 10 band parametric equalizer enabling you to set any of the 10 default frequencies (32Hz, 62Hz, 125Hz, 250Hz, 500Hz, 1000Hz, 2000Hz, 4000Hz, 8000Hz, 16000Hz) to any value from 20Hz to 20KHz. Each band is set individually by selecting the band from the Band menu then adjusting the remaining settings. A dynamic graph displays the resulting frequency response of the equalizer band. Changing the Gain, Frequency, or Q settings can change the frequency response.

Use the following options to change the settings on the equalizer:

Band: Use the menu to select which of the 10 equalizer bands you want to configure.

Filter Type: Use the menu to set the filter type for the selected equalizer band. You can choose from Bell, Band Pass, Band Stop, High Pass, Low Pass, Treble Shelf, and Bass Shelf.

Frequency: Use the up and down arrows or direct text entry to set the center frequency for the selected equalizer band. You can set the center frequency to any value between 20Hz and 20KHz.

Gain: Use the up and down arrow buttons or direct text entry to adjust the gain/attention level of the selected band. You can set the gain from -12 to +12dB in 1dB increments. The default setting is 0.

Q: Q factor adjusts the filter from wider to narrower smoothing between inflection points on the frequency response. The default setting is 1.4. The range is from 0.1 to 20.0 in 0.1 increment/decrement steps.

Tone Adjust: Use the menu to select a fixed adjustment to the frequency response depending on the current use. You can choose from Off, Movie, Voice, and Music.

Reset EQ: Click to reset all EQ levels to 0.

Enabled: Click to enable or disable the equalizer settings.

9 - Ducking: Use the menu to set the ducking level of the audio output. You can choose from Off, Low, Medium, High, and Custom. Selecting Custom activates settings you can adjust for Threshold, Attack, Release, Attenuation, and Hold-time. The default setting is Off.

Priority: Use this menu to set the ducking priority for the microphones. You can choose from Off or Mic1.

Threshold: Use the sliders to adjust the threshold levels for each microphone. You can set the threshold to any value between 0 and -50.

10 - Mix: Use the sliders to set the mix levels for the audio input and the two microphones. Each device has its own mix level slider. You can set each level from 0 to 100dB.

Audio In/Microphone

FIG. 74 displays the Audio In/Microphone page for the DVX.

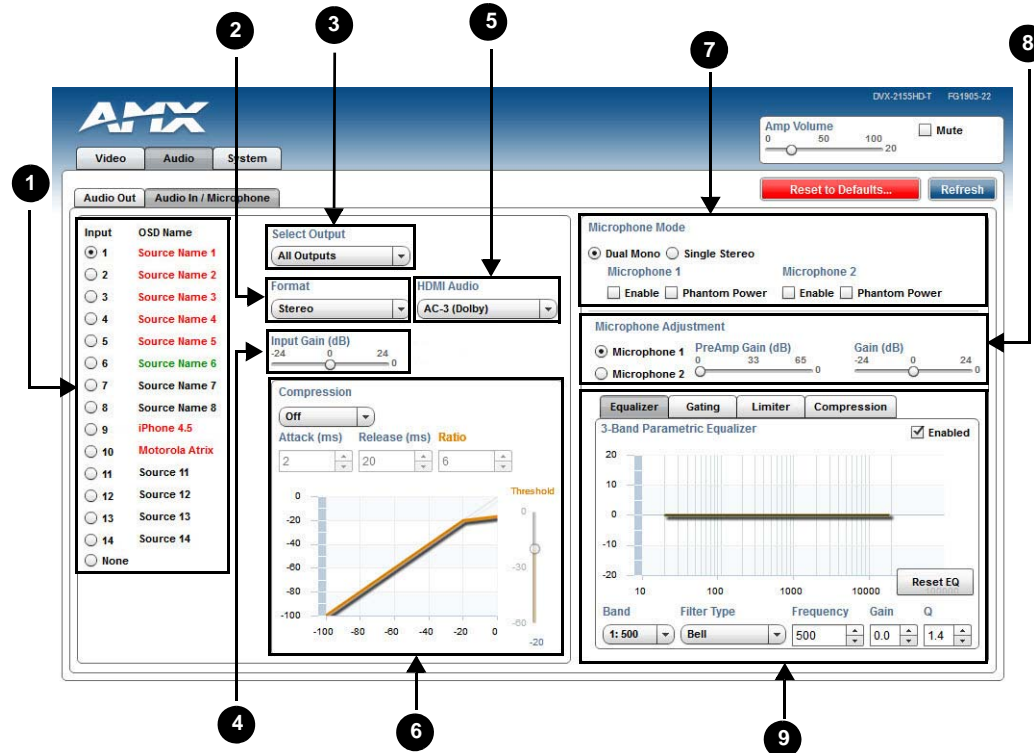

FIG. 74 WebConsole Configuration page - Audio In/Microphone tab

1 - **Audio Input:** Select the corresponding option button to switch that audio signal to the selected output. You can only select one audio input at a time. Select None if you do not want any audio.

2 - **Format:** Use the menu to select the analog format for the audio input. You can choose from *Stereo* or *Mono*.

3 - **Select Output:** Use the menu to select an audio output.

4 - **Input Gain:** Use the slider to adjust the gain level of the audio input. You can set the gain from -24 to +24dB in 1dB increments. The default setting is 0.

5 - **HDMI Audio:** Use the menu to select the HDMI Audio type for the audio input. This option is not available if you select a mirrored input for the EDID Mode on the Video In tab.

6 - **Compression:** Use the menu to select the compression level of the selected audio input. You can choose from *Off*, *Low*, *Medium*, *High*, and *Custom*. The default value is *Off*. Selecting any option other than *Off* enables you to adjust settings for Attack, Release, Ratio, and Threshold.

Attack: Sets the duration, in milliseconds, of the attack phase while compressing. You can set a value between 1 and 2000.

Release: Sets the duration, in milliseconds, of the release phase while compressing. You can set a value between 1 and 5000.

Ratio: Sets the ratio while compressing. You can set a value between 1 and 20.

Threshold: Sets the threshold while compressing. You can set a value between 0 and -60.

7 - **Microphone Mode:** Click *Dual Mono* when using independent microphones. Each mono microphone input is mixed onto both the right and left channels. Click *Single Stereo* when connecting a single stereo source.

Microphone input 1 is mixed only onto the left channel and Microphone input 2 is mixed only onto the right channel. Click the check boxes to activate phantom power for each individual mic. The unit supports a supply of up to 48V of phantom power for each mic input.

NOTE: *Enabling Phantom Power could damage some devices connected to the microphone input if the devices are not designed to accept it.*

8 - **Microphone Adjustment:** There are two separate sections for configuring Mic 1 and Mic 2. If you select *Single Stereo* for the Microphone Mode, there is a single configuration that affects both microphones. Selecting *Dual Mono* allows independent configuration of each mic. You can set the following options for each microphone:

PreAmp Gain: Use the slider to set the preamp gain level for the mic. You can set the PreAmp Gain between 0 and 65 dB in 1 dB steps. Set the PreAmp Gain to 0 for line-level inputs.

Gain: Use the slider to set the input gain level for the mic. You can set the gain between -24 and +24 dB in 1 dB steps.

9 - This area contains a set of four tabs with different sets of options for more advanced microphone adjustments.

Equalizer: The equalizer is a 3-band parametric equalizer enabling you to set 3 frequencies to any value from 20Hz to 20KHz. The default center frequencies are 500Hz, 1000Hz, and 3000Hz. Each band is set individually by selecting the band from the Band menu then adjusting the remaining settings. A dynamics chart displays any activity on the equalizer band. Changing the Gain, Frequency, or Q settings can change the chart display.

Use the following options to change the settings on the equalizer:

Band: Use the menu to select which of the 3 equalizer bands you want to configure.

Filter Type: Use the menu to set the filter type for the selected equalizer band. You can choose from Bell, Band Pass, Band Stop, High Pass, Low Pass, Treble Shelf, and Bass Shelf.

Frequency: Use the up and down arrows or direct text entry to set the center frequency for the selected equalizer band. You can set the center frequency to any value between 20Hz and 20KHz.

Gain: Use the up and down arrow buttons or direct text entry to adjust the gain/attention level of the audio input. You can set the gain from -12 to +12dB in 1dB increments. The default setting is 0.

Q: Q factor adjusts the vector graph from wider to narrower smoothing between inflection points on the equalizer band. The default setting is 1.4. The range is from 0.1 to 20.0 in 0.1 increment/decrement steps.

Gating: Use the menu to select the gating level of the selected microphone input. You can choose from Off, Low, Medium, High, and Custom. The default value is Off. Selecting any option other than Off enables you to adjust settings for Attack, Release, Depth, Hold Off, and Threshold.

Limiters: Use the menu to select the Limiter settings of the selected microphone input. You can choose from Off, Low, Medium, High, and Custom. The default value is Off. Selecting any option other than Off enables you to adjust settings for Attack, Release and Threshold.

Compression: Use the menu to select the compression level of the selected Microphone input. You can choose from Off, Low, Medium, High, and Custom. The default value is Off. Selecting any option other than Off enables you to adjust settings for Attack, Release, Ratio, and Threshold.

The following settings serve identical purposes with identical ranges for each tab on which they appear:

Attack: Sets the duration, in milliseconds, of the attack phase. You can set a value between 1 and 2000.

Release: Sets the duration, in milliseconds, of the release phase. You can set a value between 1 and 5000.

Depth: Sets the depth in decibels. You can set a value between 0 and 20.

Ratio: Sets the ratio. You can set a value between 1 and 20.

Hold Off: Sets the gating hold off time. You can set a value between 0.25 and 4 seconds in 0.25 increments.

Enabled: Click to enable or disable the equalizer settings.

NOTE: Your audio configuration is not affected by a power loss, restarting the unit, or upgrading the firmware.

Setting Up Surround Audio

To pass surround audio from HDMI inputs to HDMI or S/PDIF outputs you must have an HDMI sink (display, AVR, etc.) that supports one or more surround formats. Follow these steps to configure the DVX to pass-through surround audio.

1. Connect a source that is capable of providing surround audio to an HDMI input on the DVX.
2. Connect a sink that supports surround audio to an HDMI output on the DVX.
3. See *Using a Web Browser* section on page 63 and follow the instructions to open the DVX Web Configuration page.
4. To manually select an audio format to request from the source (switcher firmware 1.4.4 or higher):
 - On the Audio In tab, select the HDMI Input connected to the source.
 - Select the desired surround format from the **HDMI Audio** options menu.
5. To pass an HDMI sink's audio capabilities to the source device:
 - On the Video In tab, select the HDMI Input connected to the source.
 - Select Mirror Out x from the **EDID Mode** options menu where x is the output number connected to the surround-capable sink (see item 6 in the *Video In* section on page 67 for more information.)
6. In the HDMI Output section of the Audio Out tab, select the HDMI output that is the destination for surround audio and then Select Input Pass-Thru from the **Audio Source** options menu (see item 3 in the *Audio Out* section on page 68 for more information).
7. If sending surround audio to the S/PDIF output, select the same HDMI output used in step 6 above in the **S/PDIF Output Audio Source** options menu (see item 4 in the *Audio Out* section on page 68 for more information).
8. Route the video from the HDMI input connected to the surround audio source to the HDMI output selected in step 6 above.

Follow these same steps when receiving surround audio from a DXLink input and/or sending audio to DXLink outputs. Connect all DXLink transmitters/receivers to the DVX, connect sources and sinks to DXLink transmitters/receivers, and select the appropriate DXLink input/output on the DVX in the steps above.

Embedding Audio on an HDMI Output

Follow these steps to configure an HDMI, DXLink or S/PDIF output to embed audio from a stereo source:

1. Connect either a digital audio source on an HDMI input or an analog audio source on one of the analog audio inputs.
2. Connect an HDMI sink (display, AVR, etc.) that can accept audio over HDMI.
3. See *Using a Web Browser* section on page 63 and follow the instructions to open the DVX Web Configuration page.
4. In the HDMI Output section of the Audio Out tab, select the HDMI output that is the destination for audio and then select the analog output you want to embed from the **Audio Source** options menu. (See item 3 on *Audio Out* section on page 68 for more information).
5. Route the desired input audio (connected in step 2) to the analog output chosen in step 4, and it will automatically embed on the selected HDMI and/or S/PDIF output.
6. In the HDMI Output section, select the **Apply EQ** check box if you want the audio on the HDMI output to be affected by the DVX's Volume and Equalizer settings. De-select this box if you want un-equalized, unity gain audio on the HDMI output (recommended if adjusting volume and EQ at the downstream HDMI sink).
7. To send the same analog audio to the S/PDIF output, select the same Analog output used in step 4 above in the **S/PDIF Output Audio Source** options menu (see item 4 in the *Audio Out* section on page 68 for more information).

Mixing Microphones onto Analog and HDMI Outputs

Follow these steps to connect and mix audio from a microphone input onto the source audio being routed to an audio output. The Mic inputs can accept both Microphone level and Line level audio.

1. Connect an audio source to one of the microphone inputs on the DVX.
2. See *Using a Web Browser* section on page 63 and follow the instructions to open the DVX Web Configuration page.
3. On the Audio In / Microphone tab, select the appropriate Pre-Amp gain setting for the input type you are using (see item 7 in the *Audio In/Microphone* section on page 70 for more information):
 - If the input source connected to the microphone input is a line-level signal, adjust the Pre-Amp Gain for that microphone input to 0.
 - If the input source connected to the microphone input is a microphone-level signal, adjust the Pre-Amp Gain for that microphone to a setting above 0 (typical values are between 20 and 30 dB).
4. If the connected microphone requires phantom power, check the Phantom Power check box for that microphone input (see item 6 in the *Audio In/Microphone* section on page 70 for more information).
5. In the same section, turn on the connected microphone by checking the Enable check box for that microphone input.
6. On the Audio Output tab, select each analog audio output (see item 1 in the *Audio Out* section on page 68) and adjust the mix level as desired for each output (see item 10 in the *Audio Out* section on page 68).
 - To hear both program audio and microphone audio on an analog output, start by setting the mix sliders for both the Input and the Mic all the way up and then make minor adjustments to these sliders to achieve the desired relative audio levels.
 - To hear only the program audio on an analog output, set the microphone mix levels all the way down (-100) and the Input mix level all the way up.
 - To hear only the microphone on an analog output, set the Input mix level all the way down (-100) and the Mic mix level all the way up.
7. To hear the microphone on an HDMI output, follow the instructions for *Mixing Microphones onto Analog and HDMI Outputs* section on page 72 and select an analog output that has been mixed to receive microphone audio in step 6 above.

System Settings

FIG. 75 displays the System page. The System page allows you to switch any audio or video input to any output, set the front panel button lockout, adjust front panel LED and LCD intensity, and view the device information for the switcher.

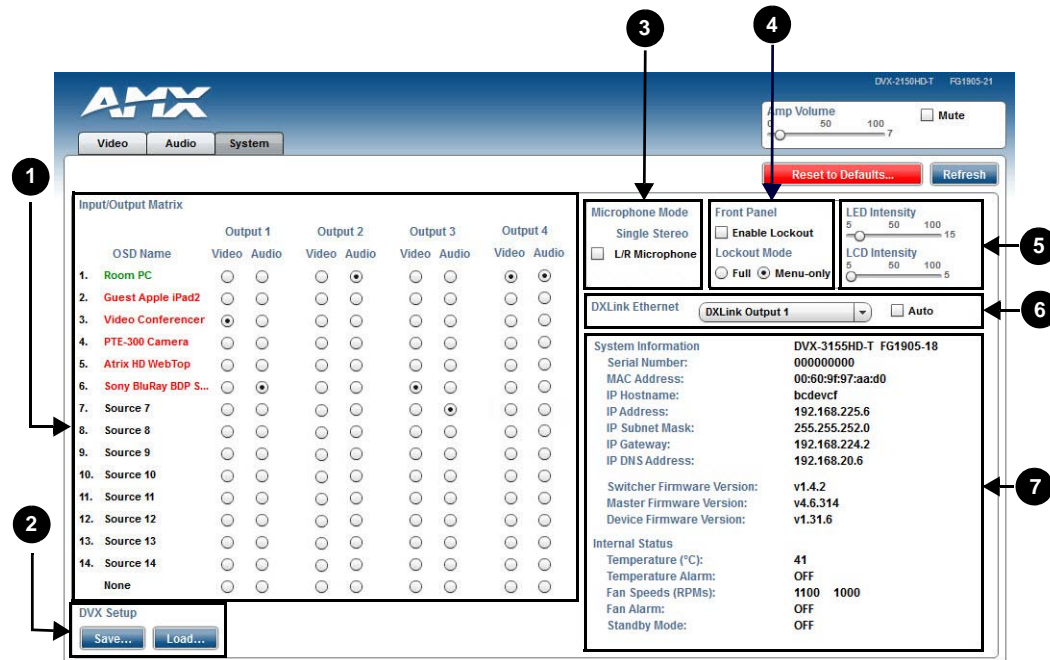

FIG. 75 WebConsole Configuration page - System page

1 - **Input/Output Matrix:** Select an option button under each output to switch video or audio from the corresponding input to that particular output. Green text indicates a signal is detected, gray indicates a signal is detected but cannot be identified, and red indicates no signal is detected. You can only select one video and audio input at a time per output. Select None if you do not want any video or audio on the selected output.

2 - **Save/Load:** Click the buttons to save or load your DVX settings. Files are saved as a .xdv file to any local or network drive of your specification.

NOTE: Due to the way many browsers manage file upload requests while in an authenticated session, it is not possible to load a DVX setup (.xdv) file with any web browser AMX has tested, except Microsoft Internet Explorer when HTTP Security is enabled on the DVX Master.

3 - **Microphone Mode:** Click the checkboxes to activate or deactivate the microphones connected to Mic Inputs 1 and 2 when in Dual Mode, or the L/R Microphone when in Single Stereo Mode.

4 - **Front Panel Lockout Mode:** Click the check box to activate a lockout of some or all of the buttons on the front panel. Select the type of lockout in the Lockout Mode section. Select Full Lockout if you want the lockout to block the use of all front panel buttons. Select Menu-only Lockout if you want the lockout to only block the use of the menu options on the front panel. The Switch, Take, Status, Volume, and Mute buttons are still available with this option.

5 - **Front Panel Backlight:** Use the sliders to adjust the backlight intensity of the LCD display and the LEDs on front panel buttons. You can set the backlight intensity for each option between 0 and 100. The default setting for each option is 50.

6 - **DXLink Ethernet:** Use the menu to select the DXlink Input or the DXLink Output, then click the Auto check box to enter Auto mode for the selected input or output. In Auto mode, Ethernet traffic is enabled if the port is connected to an end-point transmitter or receiver, but is automatically disabled if connected to a port on another Enova DVX or DGX. When Auto is not checked, Ethernet is turned off for the selected port.

7 - **System Information:** This area provides the following read-only information about your unit:

Serial number	IP Gateway	Temperature (°C)
MAC Address	IP DNS Addresses	Temperature Alarm
IP Hostname	Switcher Firmware Version	Fan Speeds (RPMs)
IP Address	Master Firmware Version	Fan Alarm
IP Subnet Mask	Device Firmware Version	Standby Mode

NetLinx Firmware Upgrades

Overview

Upgrading firmware on Enova DVX All-In-One Presentation Switchers involves downloading the latest firmware files from www.amx.com and using NetLinx Studio to transfer the files to a target DVX. The NetLinx Studio software application (available for free download from www.amx.com) provides the ability to transfer KIT firmware files to a NetLinx device such as the DVX.

Use the Online Device tree in NetLinx Studio to view the firmware files currently loaded on the Central Controller. FIG. 76 shows an example Online Tree:

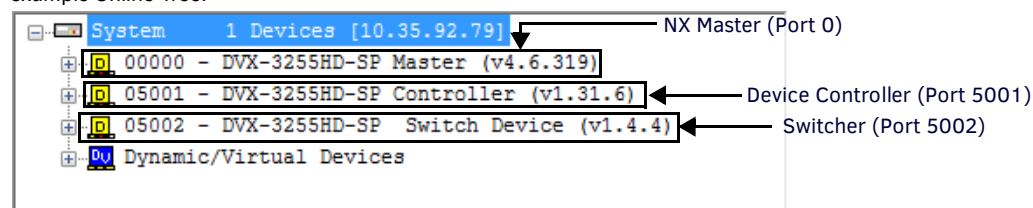

FIG. 76 NetLinx Studio - Sample Online Tree

DVX Switchers contain three devices (NX Master, Device Controller, and A/V Switcher/Scaler), each of which requires a separate Kit file. These three devices must be kept at compatible firmware versions for proper operation. Therefore, all three files should be used when upgrading any firmware associated with the DVX.

DVX Controllers - Firmware Files	
NX Master Firmware	The on-board NX Master is listed first in the Online Tree as "00000 NX Master (<firmware version>") <ul style="list-style-type: none"> • "00000" represents Device ID 0, which is reserved for the Master • The number in parenthesis is the current Master firmware version.
Device Controller Firmware	The Device Controller is listed next as "05001 NX-XXXX (<firmware version>") <ul style="list-style-type: none"> • "05001" represents Device ID 5001, which is reserved for the Device Control ports. • The number in parenthesis is the current Device Controller firmware version.
A/V Switcher/Scaler Firmware	The A/V Switcher/Scaler is listed third as "05002 NX-XXXX (<firmware version>") <ul style="list-style-type: none"> • "05002" represents Device ID 5002, which is reserved for the A/V Switcher/Scaler. • The number in parenthesis is the current Device Controller firmware version.

Before You Start

Perform the following steps before upgrading your firmware version:

1. Verify you have the latest version of NetLinx Studio on your PC. Use the **Web Update** option in NetLinx Studio's Help menu to obtain the latest version. Alternatively, go to www.amx.com and login as a Dealer to download the latest version.
2. Go to www.amx.com and download the latest Firmware file. Firmware files are available to download from www.amx.com - on the product's page in the online catalog.
3. Verify that an Ethernet cable is connected from the DVX to the Ethernet Hub.
4. Verify that the DVX is powered On.
5. Determine the Device Number assigned to the target DVX.
 - By default, the Device Number assigned to the DVX is **0** (zero). (The Master device number is always 0 and cannot be changed.)
 - The Device Number can be viewed on the DVX Configuration Manager - Device Configuration page.
6. Launch NetLinx Studio and open the Online Device Tree.

Verifying the Current Firmware Version

Use the Online Tree in NetLinx Studio (see FIG. 76 on page 74) to verify which version of each firmware file is currently installed.

1. In NetLinx Studio, click on the Online Tree tab (in the Workspace Bar) to view the devices on the System.
2. Click **Display** and select **Refresh System Online Tree** from the context menu that appears. This establishes a new connection to the System and populates the device tree with devices on that system.
3. After the Communication Verification dialog box indicates active communication between the PC and the Central Controller, verify the Central Controller and associated devices are listed in the Online Tree.
4. Check the appropriate product page on www.amx.com for the latest NX Master, Device Controller, and A/V Switcher/Scaler firmware files for your device.

If necessary, follow the procedures outlined in the following sections to obtain these firmware (*.kit) files from **www.amx.com** and then transfer the new firmware files to the device.

Downloading the Latest Firmware Files from www.amx.com

Below is a table outlining the *Master*, *Device*, and *Switcher* firmware (*.kit) files used by Enova DVX Controllers:

Master Firmware Kit File Usage for Enova DVX Controllers	
DVX-3250/3255/3256HD/ 2250/2255/2210HD	Master Firmware: SW2106_NX-X200_Master_v1_x_xxx.kit
	Device Firmware: SW2106_NX_X200_Device_v1_x_xx.kit
	A/V Switcher/Scaler Firmware: SW1906_DVX-x2xx_Switcher_v1_x_xx.kit

Downloading Enova DVX Firmware Files on www.amx.com

Visit the appropriate product page on www.amx.com for the latest *NX Master* and *Device Controller* firmware (*.kit) files for your DVX. Firmware file links are available along the right-side of the catalog page (FIG. 77):



FIG. 77 www.amx.com - sample Enova DVX firmware file links

Firmware files are bundled in a ZIP file, along with a Readme.TXT file that provides details on this firmware release.

1. Accept the AMX Licensing Agreement.
2. Download the ZIP file and unzip the contents to a known location.

Required Order of Firmware Updates for DVX Controllers

Upgrade firmware in the following order:

1. First, upgrade the A/V Switcher/Scaler firmware.
2. When that process is complete, upgrade the **Master** firmware.
3. When that process is complete, upgrade the **Device** firmware.

NOTE: ALWAYS consult the *Readme.TXT* file bundled with the firmware file for any special instructions before upgrading to a newer firmware version. If no specifics are provided, use the order provided above.

Sending Firmware (*.KIT) Files to the DVX

Use the Firmware Transfers options in the Tools menu to update the firmware in the DVX. NetLinx Devices such as the DVX use KIT files for firmware upgrades.

NOTE: A *Kit file (*.KIT)* is a package of several files, all of which are required to upgrade the firmware, and are available online via www.amx.com. Firmware download links are provided in the relevant product page.

- The Online Device Tree (Online Tree tab of the Workspace Window) displays information about each online device, including the current firmware version.
- Before attempting to upgrade the firmware, you must have the appropriate Kit file for your DVX.

The DVX contains two devices which each require a separate Kit file. These three devices must be kept at compatible firmware versions for proper operation.

- Device ID 0: NetLinx Master Controller
- Default Device ID 5001: Device Control Ports

To update NetLinx firmware:

1. Choose Tools > Firmware Transfers > Send to NetLinx Device to open the Send To NetLinx Device dialog box (FIG. 78).

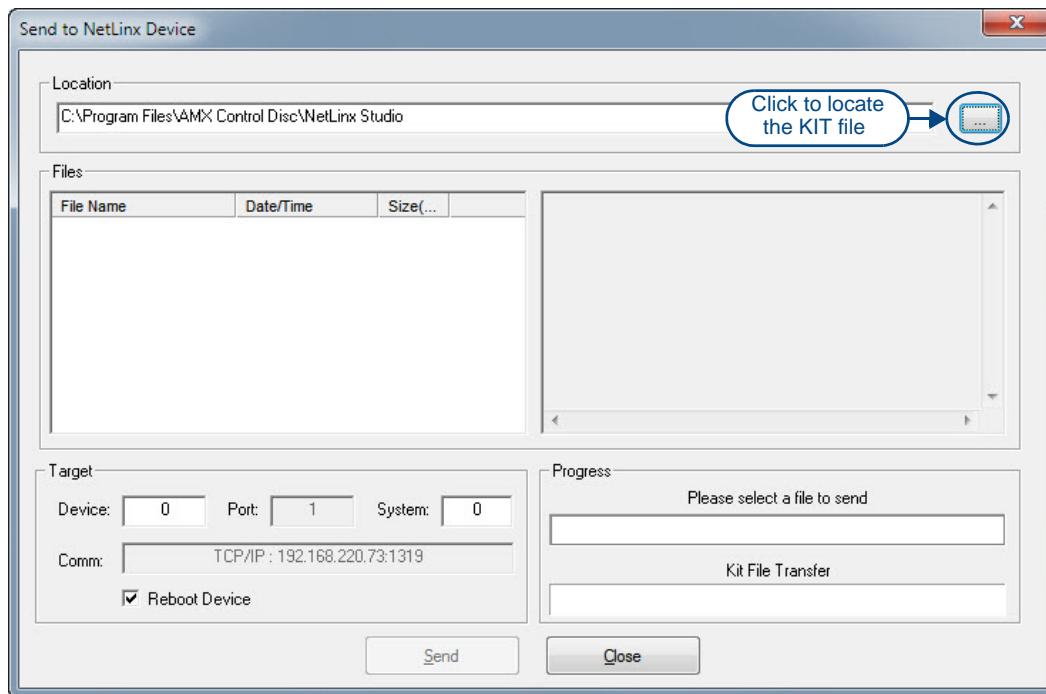

FIG. 78 Send to NetLinx Device dialog box (NetLinx Studio)

2. Click the Browse (...) button to navigate to the target directory in the Browse For Folder dialog box (FIG. 79).

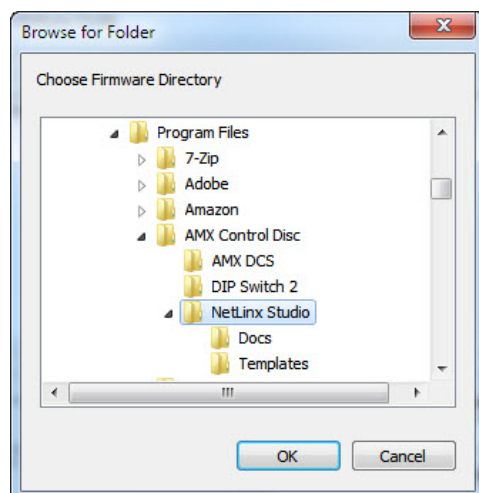

FIG. 79 Browse For Folder dialog box (NetLinx Studio)

- The selected directory path is displayed in the Send To NetLinX Device dialog (Location text box).
- Assuming that the specified target directory contains one or more KIT files, the KIT files in the selected directory are displayed in the Files list box, with the file's last modified date and time (FIG. 80).

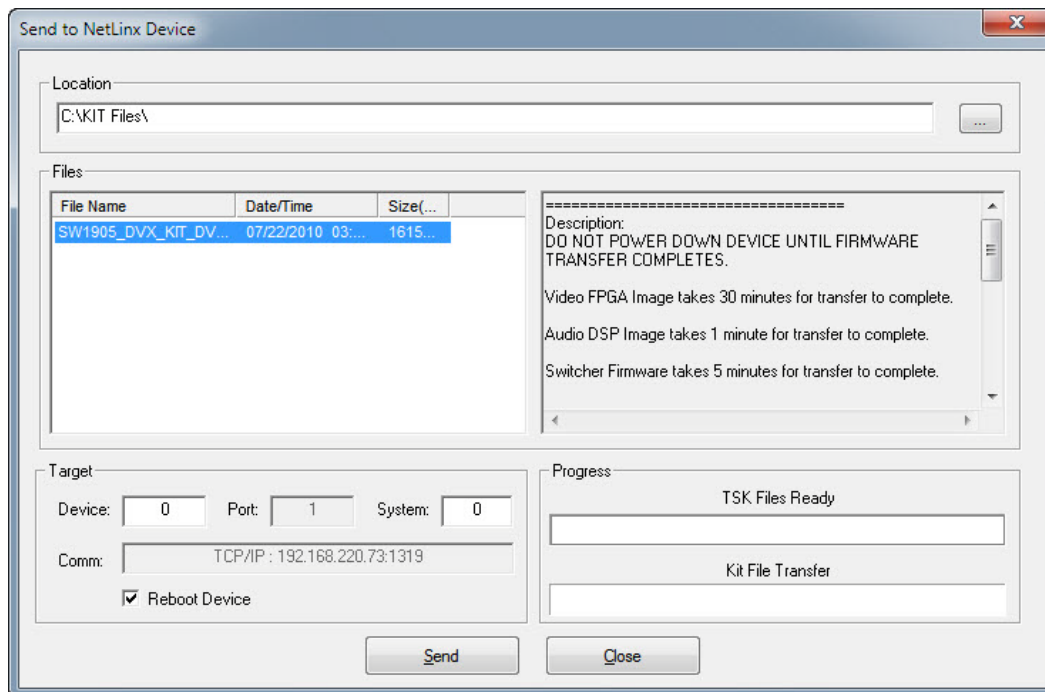

FIG. 80 Send to NetLinX Device dialog box (NetLinX Studio)

3. Select the appropriate *.KIT file from the Files list.

NOTE: Always update DVX devices in the following order:

Device 0 (NetLinX Master)

Device 5001 (Integrated Control Ports)

ALWAYS consult the Readme.TXT file bundled with the firmware file for any special instructions before upgrading to a newer firmware version. If no specifics are provided, use the order provided above.

4. Enter the Device ID number of the integrated device to be upgraded in the Device text box and the System ID numbers for the DVX in the System text box.

- The device number of the NetLinX Master is 0.
- By default, the Device number assigned to the integrated control ports is 5001.
- Use the Online Device Tree to determine the device's assigned IDs, if it has been changed.

5. Review the File, Connection, Address, and Target Device information before you send.

6. Click the Send button. You can watch the progress of the transfer in the Send to NetLinX Device dialog box.

NetLinX Studio transfers the files to the DVX and then tells it to reboot. After it reboots, the DVX actually goes through the upgrade process.

- During the upgrade process, the Status LED blinks, and the DVX stays offline.
- Once the upgrade is complete, the LED will stop blinking and the DVX will be online.
- Repeat the firmware update process for the next device until all devices are updated.

NOTE: Upgrading the Master or device firmware can take several minutes. If you are unsure of the progress of the upgrade, you can see the status of the upgrade on the LCD display on the front panel of the All-In-One Presentation Switcher.

CAUTION: If for any reason your Kit file transfer should fail, continue to retry the transfer until you are successful. DO NOT reboot the DVX, or change connections until the transfer is complete. Failure to complete this operation successfully may require a factory repair of the DVX.

Additional Documentation

For additional information on using NetLinX Studio, refer to the NetLinX Studio online help and Instruction Manual (available at www.amx.com).

Programming

Overview

The chapter defines all programming commands available for the DVX.

NOTE: This chapter lists programming commands unique to the DVX. Please consult the *WebConsole & Programming Guide for NX-Series Controllers* for more details on NetLinx controller commands. The DVX supports all commands compatible with the NX-3200 (325x-series DVX) and NX-2200 (22xx-series DVX).

CAUTION: Some DVX-2100HD commands operate under different names on the DVX-325xHD and DVX-22xxHD. The functionality of these commands are identical to their original counterparts.

The following table lists the commands which have changed and the new name of the command.

SEND_COMMAND Changes	
Original Command	New Command
AUDIO_MUTE	AUDOUT_MUTE
?AUDIO_MUTE	?AUDOUT_MUTE
GAIN	AUDIN_GAIN
?GAIN	?AUDIN_GAIN
INPUTEQ	AUDMIC_EQ_GAIN
?INPUTEQ	?AUDMIC_EQ_GAIN
PHANTOM_PWR	AUDMIC_PHANTOM_PWR
?PHANTOM_PWR	?AUDMIC_PHANTOM_PWR
OSD	VIDOUT_OSD
?OSD	?VIDOUT_OSD
VIDEO_MUTE	VIDOUT_MUTE
?VIDEO_MUTE	?VIDOUT_MUTE
VIDEO_TESTPATTERN	VIDOUT_TESTPAT
?VIDEO_TESTPATTERN	?VIDOUT_TESTPAT
VIDEO_RES_AUTO	VIDOUT_SCALE
?VIDEO_RES_AUTO	?VIDOUT_SCALE
VIDIN_COLOR	VIDIN_BW
?VIDIN_COLOR	?VIDIN_BW
VOLUME	AUDOUT_VOLUME
?VOLUME	?AUDOUT_VOLUME

NetLinX Channels and Levels

The following sections define the NetLinX channels and levels available for the DVX-3250HD/3255HD/3256HD:

DVX-325xHD NetLinX Channels

DVX-325xHD NetLinX Channels		
Channel	Ports	Description
24	1-4	Volume Up
25	1-4	Volume Down
26	1-4	Volume Mute Cycle
32	1-4	Switches video input 1 to the video output specified in the DPS
32	1-4	Switches video input 2 to the video output specified in the DPS
33	1-4	Switches video input 3 to the video output specified in the DPS
34	1-4	Switches video input 4 to the video output specified in the DPS
35	1-4	Switches video input 5 to the video output specified in the DPS
36	1-4	Switches video input 6 to the video output specified in the DPS
37	1-4	Switches video input 7 to the video output specified in the DPS
38	1-4	Switches video input 8 to the video output specified in the DPS
39	1-4	Switches video input 9 to the video output specified in the DPS
40	1-4	Switches video input 10 to the video output specified in the DPS
41	1-4	Switches audio input 1 to the video output specified in the DPS
42	1-4	Switches audio input 2 to the video output specified in the DPS
43	1-4	Switches audio input 3 to the video output specified in the DPS
44	1-4	Switches audio input 4 to the video output specified in the DPS
45	1-4	Switches audio input 5 to the video output specified in the DPS
46	1-4	Switches audio input 6 to the video output specified in the DPS
47	1-4	Switches audio input 7 to the video output specified in the DPS
48	1-4	Switches audio input 8 to the video output specified in the DPS
49	1-4	Switches audio input 9 to the video output specified in the DPS
50	1-4	Switches audio input 10 to the video output specified in the DPS
51	1-4	Switches audio input 11 to the video output specified in the DPS
52	1-4	Switches audio input 12 to the video output specified in the DPS
53	1-4	Switches audio input 13 to the video output specified in the DPS
54	1-4	Switches audio input 14 to the video output specified in the DPS
70	1-4	Video Output Enable
71	1-2	Mic Enable (Mono)
71	3	Mic Enable (Stereo)
83	1-10	Video In Phase Ramp Up
84	1-10	Video In Phase Ramp Down
100	1	Standby Mode. See the <i>Standby Mode</i> on page 81 for more information.
132	1-10	Video In V-Shift Ramp Up
133	1-10	Video In V-Shift Ramp Down
134	1-10	Video In H-Shift Ramp Up
135	1-10	Video In H-Shift Ramp Down
140	1-14	Gain Up
141	1-14	Gain Down
142	1-10	Black and White State
143	1-14	Gain Mute
144	1-14	Gain Cycle
148	1-10	Video In Brightness Ramp Up
149	1-10	Video In Brightness Ramp Down
150	1-10	Video In Saturation Ramp Up

NetLinx Channels (Cont.)		
Channel	Ports	Description
151	1-10	Video In Saturation Ramp Down
152	1-10	Video In Contrast Ramp Up
153	1-10	Video In Contrast Ramp Down
156	1-10	Video In Hue Ramp Up
157	1-10	Video In Hue Ramp Down
158	1-4	Output Zoom Ramp Up
159	1-4	Output Zoom Ramp Down
164	1-4	Balance Ramp Up
165	1-4	Balance Ramp Down
196	1-4	Source Cycle
199	1-4	Volume Mute Set and State
210	1-4	Video Mute State
213	1-4	Video Freeze State
216	1	Fan Alarm
217	1	Temperature Alarm
234	1-4	OSD State

DVX-22xxHD NetLinx Channels

The following table lists the NetLinx channels for the 22xx DVX models.

DVX-22xx NetLinx Channels		
Channel	Ports	Description
24	1-3	Volume Up
25	1-3	Volume Down
26	1-3	Volume Mute Cycle
31	1-3	Switches video input 1 to the video output specified in the DPS
32	1-3	Switches video input 2 to the video output specified in the DPS
33	1-3	Switches video input 3 to the video output specified in the DPS
34	1-3	Switches video input 4 to the video output specified in the DPS
35	1-3	Switches video input 5 to the video output specified in the DPS
36	1-3	Switches video input 6 to the video output specified in the DPS
41	1-3	Switches audio input 1 to the video output specified in the DPS
42	1-3	Switches audio input 2 to the video output specified in the DPS
43	1-3	Switches audio input 3 to the video output specified in the DPS
44	1-3	Switches audio input 4 to the video output specified in the DPS
45	1-3	Switches audio input 5 to the video output specified in the DPS
46	1-3	Switches audio input 6 to the video output specified in the DPS
47	1-3	Switches audio input 7 to the video output specified in the DPS
48	1-3	Switches audio input 8 to the video output specified in the DPS
70	1-2	Video Output Enable
71	1-2	Mic Enable (Mono)
71	3	Mic Enable (Stereo)
83	1-2	Video In Phase Ramp Up
84	1-2	Video In Phase Ramp Down
100	1	Standby State. See the <i>Standby Mode</i> on page 81 for more information.
132	1-6	Video In V-Shift Ramp Up (only applicable when routed to a scaled output)
133	1-6	Video In V-Shift Ramp Down
134	1-6	Video In H-Shift Ramp Up
135	1-6	Video In H-Shift Ramp Down
140	1-6	Audio Input Gain Up

DVX-22xx NetLinx Channels (Cont.)		
Channel	Ports	Description
141	1-6	Audio Input Gain Down
142	1-6	Black and White State
143	1-6	Audio Input Gain Mute (Reserved for future use)
144	1-6	Audio Input Gain Mute Cycle (Reserved for future use)
148	1-6	Video In Brightness Ramp Up (only applicable when routed to a scaled output)
149	1-6	Video In Brightness Ramp Down (only applicable when routed to a scaled output)
150	1-6	Video In Saturation Ramp Up (only applicable when routed to a scaled output)
151	1-6	Video In Saturation Ramp Down (only applicable when routed to a scaled output)
152	1-6	Video In Contrast Ramp Up (only applicable when routed to a scaled output)
153	1-6	Video In Contrast Ramp Down (only applicable when routed to a scaled output)
156	1-6	Video In Hue Ramp Up (only applicable when routed to a scaled output)
157	1-6	Video In Hue Ramp Down (only applicable when routed to a scaled output)
158	1-2	Output Zoom Ramp Up
159	1-2	Output Zoom Ramp Down
164	1-3	Audio Output Balance Ramp Left (output 1 is only applicable on -SP units)
165	1-3	Audio Output Balance Ramp Right (output 1 is only applicable on -SP units)
196	1-3	Source Cycle
199	1-3	Volume Mute Set and State
210	1-3	Video Mute Set and State
213	1-2	Video Freeze Set and State
216	1	Fan Alarm (read-only channel)
217	1	Temperature Alarm (read-only channel)
234	1-2	OSD State

Channel Video Switching

To switch video via channels, the channel must be turned ON (as opposed to pulsing the channel).

For example, turn on Channel 31 on Port 1 for Input 1 to output video.

- The DVX-325x video channels are 31-40 (Ports 1-4) - see *DVX-325xHD NetLinx Channels* on page 79
- The DVX-22xx video channels are 31-36 (Ports 1-3) - see *DVX-22xxHD NetLinx Channels* on page 80

These channels are mutually exclusive:

- *Turning On* another channel will change input and turn off the last channel.
- *Turning Off* a selected channel will select input *none*.
- *Pulsing* any channel will set input to *none* as it turns on, and then back off the channel pulsed.

Standby Mode

You can activate Standby Mode using one of the following methods:

- You can activate Standby Mode via channel 100 on the DVX. Set channel 100 to ON to activate Standby Mode. Deactivate Standby Mode by setting channel 100 to OFF.
- You can activate Standby Mode by accessing the Status menu on the front panel LCD display. Use the navigational buttons on the front panel to locate the Enter Standby Mode option in the Status menu, and use the left and right arrow buttons to set the value to YES to activate Standby Mode.

The following points apply to Standby Mode on the DVX:

- After exiting Standby Mode, the DVX cannot re-enter Standby Mode for a period of 20 seconds. Any attempt to re-enter standby mode within this 20 second window is ignored.
- When the DVX enters Standby Mode, all video and audio circuitry are turned off. The DVX does not produce a video or audio output signal in low power state.
- The 5002 Device stays online when Standby Mode is active.
- All switch and configuration commands sent while in Standby Mode are implemented, and any changes will be noticed after the DVX exits Standby Mode.
- All audio and video signals are restored in less than 10 seconds after exiting Standby Mode.
- The DVX exits Standby Mode on any power cycle or reboot.

DVX-325xHD NetLinx Levels

The following table list the NetLinx levels for the 325x DVX models:

DVX-325xHD NetLinx Levels			
Level	Ports	Range	Function
1	1-4	0-100	Output volume
2	1-4	(-20)-(20)	Audio Output Balance
5	1-14	(-24)-(24)	Audio Input Gain
8	1		Temperature (read-only level)
10	1-10	0-100	Input Video Brightness
11	1-10	0-100	Input Video Saturation
12	1-10	0-100	Input Video Contrast
14	1-10	0-100	Input Video Hue
15	1-4	25-800	Video Output Zoom
17	1-10	(-50)-(50)	Video Input Horizontal Shift
19	1-10	(-10)-(10)	Video Input Vertical Shift
20	1-4	0-100	Video Output Brightness
22	1-4	0-100	Video Output Contrast
26	1-4	25-800	Video Output Horizontal Size
27	1-4	(-127)-(127)	Video Output Horizontal Shift
28	1-4	25-800	Video Output Vertical Size
29	1-4	(-127)-(127)	Video Output Vertical Shift
32	1-4	(-12)-(12)	Audio EQ Band 1
32	1-4	(-12)-(12)	Audio EQ Band 2
33	1-4	(-12)-(12)	Audio EQ Band 3
34	1-4	(-12)-(12)	Audio EQ Band 4
35	1-4	(-12)-(12)	Audio EQ Band 5
36	1-4	(-12)-(12)	Audio EQ Band 6
37	1-4	(-12)-(12)	Audio EQ Band 7
38	1-4	(-12)-(12)	Audio EQ Band 8
39	1-4	(-12)-(12)	Audio EQ Band 9
40	1-4	(-12)-(12)	Audio EQ Band 10
41	1-4	(-100)-0	Audio Program Source Mixing Level
42	1-4	(-100)-0	Audio Line Mic 1 Mixing Level
43	1-4	(-100)-0	Audio Line Mic 2 Mixing Level
50	1-4	0-10	Video Switching: Level 50 for each output port 1-4 will be a value from 0 to 10 indicating which video input is switched to that output. Changing the value of this level will result in a video switch.
51	1-4	0-14	Audio Switching: Level 51 for each output port 1-4 will be a value from 0 to 14 indicating which audio input is switched to that output. Changing the value of this level will result in an audio switch.
52	1-3	0-65	Audio Mic PreAmp Gain
53	1-3	(-24)-(24)	Audio Mic Gain
61	1-3	(-12)-(12)	Mic EQ Band 1
62	1-3	(-12)-(12)	Mic EQ Band 2
63	1-3	(-12)-(12)	Mic EQ Band 3

DVX-22xxHD NetLinx Levels

The following table list the NetLinx levels for the 22xx DVX models:

DVX-22xxHD NetLinx Levels			
Level	Ports	Range	Function
1	1-3	0-100	Output volume
2	1-3	(-20)-(-20)	Audio Output Balance
5	1-8	(-24)-(-24)	Audio Input Gain
8	1		Temperature (read-only level)
10	1-6	0-100	Input Video Brightness
11	1-6	0-100	Input Video Saturation
12	1-6	0-100	Input Video Contrast
14	1-6	0-100	Input Video Hue
15	1-2	25-800	Video Output Zoom
17	1-6	(-50)-(-50)	Video Input Horizontal Shift
19	1-6	(-10)-(-10)	Video Input Vertical Shift
20	1-2	0-100	Video Output Brightness
22	1-2	0-100	Video Output Contrast
26	1-2	25-800	Video Output Horizontal Size
27	1-2	(-127)-(-127)	Video Output Horizontal Shift
28	1-2	25-800	Video Output Vertical Size
29	1-2	(-127)-(-127)	Video Output Vertical Shift
32	1-3	(-12)-(-12)	Audio EQ Band 1
32	1-3	(-12)-(-12)	Audio EQ Band 2
33	1-3	(-12)-(-12)	Audio EQ Band 3
34	1-3	(-12)-(-12)	Audio EQ Band 4
35	1-3	(-12)-(-12)	Audio EQ Band 5
36	1-3	(-12)-(-12)	Audio EQ Band 6
37	1-3	(-12)-(-12)	Audio EQ Band 7
38	1-3	(-12)-(-12)	Audio EQ Band 8
39	1-3	(-12)-(-12)	Audio EQ Band 9
40	1-3	(-12)-(-12)	Audio EQ Band 10
41	1-3	(-100)-0	Audio Program Source Mixing Level
42	1-3	(-100)-0	Audio Line Mic 1 Mixing Level
43	1-3	(-100)-0	Audio Line Mic 2 Mixing Level
50	1-3	0-10	Video Switching: Level 50 for each output port 1-4 will be a value from 0 to 10 indicating which video input is switched to that output. Changing the value of this level will result in a video switch.
51	1-3	0-14	Audio Switching: Level 51 for each output port 1-4 will be a value from 0 to 14 indicating which audio input is switched to that output. Changing the value of this level will result in an audio switch.
52	1-3	0-65	Audio Mic PreAmp Gain
53	1-3	(-24)-(-24)	Audio Mic Gain
61	1-3	(-12)-(-12)	Mic EQ Band 1
62	1-3	(-12)-(-12)	Mic EQ Band 2
63	1-3	(-12)-(-12)	Mic EQ Band 3

SEND_COMMANDS

The commands listed in the following sections are for the switcher only. For generic NetLinx commands, see the NetLinx Integrated Controllers WebConsole and Programming Guide.

- The commands derive their input/output port addressing from the target D:P:S.
- INPUT ports range from 5-14 for Audio and from 1-10 for Video, depending on the DVX model. HDMI inputs are capable of carrying both digital audio and video signals
- The extra ports 1 and 2 on the Audio subsystem represent MIC1 and MIC2 respectively.
- There are four Audio output ports (05002:1:0, 05002:2:0, 05002:3:0, and 05002:4:0), depending on the DVX model.
- Audio Output Port #1 is the Main Amp Output and most audio commands are addressed to this port.
- Audio Output Ports 2-4 are the Line Outputs and normally track the Main Amp Output port with small exceptions.
- There are four Video output ports (05002:1:0, 05002:2:0, 05002:3:0, and 05002:4:0), depending on the DVX model.
- Input and Output functional distinctions are disambiguated from the overlapped port numbers by combining them with the command name.

Port Functionality Mapping

The following table lists the port functionality mapping for the audio/video ports on the DVX (not all ports available on each DVX model):

Port Functionality Mapping		
Port Number	Description	Address
1	Audio/Video Input 1	05002:1:0
2	Audio/Video Input 2	05002:2:0
3	Audio/Video Input 3	05002:3:0
4	Audio/Video Input 4	05002:4:0
5	Audio/Video Input 5	05002:5:0
6	Audio/Video Input 6	05002:6:0
7	Audio/Video Input 7	05002:7:0
8	Audio/Video Input 8	05002:8:0
9	Audio/Video Input 9	05002:9:0
10	Audio/Video Input 10	05002:10:0
11	Audio Input 11	05002:11:0
12	Audio Input 12	05002:12:0
13	Audio Input 13	05002:13:0
14	Audio Input 14	05002:14:0
1	Mic In 1	05002:1:0
2	Mic In 2	05002:2:0
1	Audio Output 1 (Amplified)	05002:1:0
2	Audio Output 2	05002:2:0
3	Audio Output 3	05002:3:0
4	Audio Output 4	05002:4:0
1	Audio/Video Output1	05002:1:0
2	Audio/Video Output2	05002:2:0
3	Audio/Video Output3	05002:3:0
4	Audio/Video Output4	05002:4:0

Port Numbers

The following table lists the port numbers for the DVX:

DVX Port Numbers					
DVX Model	RS-232	RS-422/485	IR/Serial	I/O	Relay
DVX-325xHD	2-4, 6-8	1, 5	11-18	22	21
DVX-22xxHD	2-4	1	11-14	22	21

AUDIO SEND_COMMANDS

The following table lists the audio SEND_COMMANDS available for the DVX:

Audio SEND_COMMANDS	
AI<input>O<output>	<p>Switches audio input port <input> to audio output port <output>.</p> <p>Syntax: SEND_COMMAND "AI<input>O<output>"</p> <p>Variables: input = The source audio input number. output = The audio output port number to switch to.</p> <p>Example: SEND_COMMAND SWITCHER, "AI2O1"</p> <p>Switch audio input port #2 to audio output #1.</p>
?AUDIN_COMPRESSION	<p>Requests the setting of compression for the audio port addressed by the D:P:S.</p> <p>Syntax: SEND_COMMAND <DEV>, "?AUDIN_COMPRESSION"</p> <p>Example: SEND_COMMAND AUDIO_INPUT_1, "?AUDIN_COMPRESSION"</p> <p>Returns a COMMAND string of the form: AUDIN_COMPRESSION-<setting>.</p>
AUDIN_COMPRESSION	<p>Sets the setting of compression for the audio port addressed by the D:P:S.</p> <p>Syntax SEND_COMMAND <DEV>, "AUDIN_COMPRESSION-<setting>"</p> <p>Variable: setting =off, low, medium, high, custom</p> <p>Example: SEND_COMMAND AUDIO_INPUT_1, "AUDIN_COMPRESSION-high"</p> <p>Sets the compression setting of the audio input port (#1 based on D:P:S) to high.</p>
?AUDIN_COMPRESSION_ATTACK	<p>Requests the compression attack for the audio port.</p> <p>Syntax: SEND_COMMAND <DEV>, "?AUDIN_COMPRESSION_ATTACK"</p> <p>Example: SEND_COMMAND AUDIO_1, "?AUDIN_COMPRESSION_ATTACK"</p> <p>Returns a COMMAND string of the form: AUDIN_COMPRESSION_ATTACK-<attack>.</p>
AUDIN_COMPRESSION_ATTACK	<p>Sets the duration of the attack phase while compressing for the audio port addressed by the D:P:S.</p> <p>Syntax: SEND_COMMAND <DEV>, "AUDIN_COMPRESSION_ATTACK-<attack>"</p> <p>Variable: attack = 1 to 2000</p> <p>Example: SEND_COMMAND AUDIO_INPUT_1, "AUDIN_COMPRESSION_ATTACK-200"</p> <p>Sets the compression attack for the audio port (#1 based on the D:P:S) to 200.</p>
?AUDIN_COMPRESSION_RATIO	<p>Requests the compression ratio for the audio port.</p> <p>Syntax: SEND_COMMAND <DEV>, "?AUDIN_COMPRESSION_RATIO"</p> <p>Example: SEND_COMMAND AUDIO_INPUT_1, "?AUDIN_COMPRESSION_RATIO"</p> <p>Returns a COMMAND string of the form: AUDIN_COMPRESSION_RATIO-<ratio>.</p>
AUDIN_COMPRESSION_RATIO	<p>Sets the ratio while compressing for the audio input port addressed by the D:P:S.</p> <p>Syntax: SEND_COMMAND <DEV>, "AUDIN_COMPRESSION_RATIO-<ratio>"</p> <p>Variable: ratio = 1 to 20</p> <p>Example: SEND_COMMAND AUDIO_INPUT_1, "AUDIN_COMPRESSION_RATIO-5"</p>
?AUDIN_COMPRESSION_RELEASE	<p>Requests the compression release for the audio port.</p> <p>Syntax: SEND_COMMAND <DEV>, "?AUDIN_COMPRESSION_RELEASE"</p> <p>Example: SEND_COMMAND AUDIO_1, "?AUDIN_COMPRESSION_RELEASE"</p> <p>Returns a COMMAND string of the form: AUDIN_COMPRESSION_RELEASE-<release>.</p>

Audio SEND_COMMANDS (Cont.)	
AUDIN_COMPRESSION_RELEASE	<p>Sets the duration of the release phase while compressing for the audio port addressed by the D:P:S.</p> <p>Syntax: SEND_COMMAND <DEV>, "'AUDIN_COMPRESSION_RELEASE-<release>'"</p> <p>Variable: release = 1 to 5000</p> <p>Example: SEND_COMMAND AUDIO_INPUT_1, "'AUDIN_COMPRESSION_RELEASE-200'"</p> <p>Sets the compression release for the audio port (#1 based on the D:P:S) to 200.</p>
?AUDIN_COMPRESSION_THRESH	<p>Requests the compression threshold for the audio port.</p> <p>Syntax: SEND_COMMAND <DEV>, "'?AUDIN_COMPRESSION_THRESH'"</p> <p>Example: SEND_COMMAND AUDIO_INPUT_1, "'?AUDIN_COMPRESSION_THRESH'"</p> <p>Returns a COMMAND string of the form: AUDIN_COMPRESSION_THRESH-<threshold>.</p>
AUDIN_COMPRESSION_THRESH	<p>Sets the threshold while compressing for the audio input port addressed by the D:P:S.</p> <p>Syntax: SEND_COMMAND <DEV>, "'AUDIN_COMPRESSION_THRESH-<threshold>'"</p> <p>Variable: threshold = 0 to -60 in dB</p> <p>Example: SEND_COMMAND AUDIO_INPUT_1, "'AUDIN_COMPRESSION_THRESH--10'"</p> <p>Sets the threshold while compressing for the selected audio input port (#1 based on D:P:S) to -10dB.</p>
?AUDIN_DIGITAL	<p>Requests the format of the audio port addressed by the D:P:S.</p> <p>Syntax: SEND_COMMAND <DEV>, "'?AUDIN_DIGITAL'"</p> <p>Example: SEND_COMMAND AUDIO_INPUT_1, "'?AUDIN_DIGITAL'"</p> <p>Returns a string of the form: AUDIN_DIGITAL-<format>..</p>
AUDIN_DIGITAL	<p>Sets the format for the audio input port addressed by the D:P:S.</p> <p>Syntax: SEND_COMMAND <DEV>, "'AUDIN_DIGITAL-<format>'"</p> <p>Variable: format = PCM-2ch, PCM-8ch, AC3, DTS, MPEG, AAC, TrueHD, DTSHD</p> <p>Example: SEND_COMMAND AUDIO_INPUT_1, "'AUDIN_DIGITAL-AAC'"</p> <p>Sets the audio format for the audio input port (#1 based on D:P:S) to AAC.</p>
?AUDIN_GAIN	<p>Requests the gain of the audio port addressed by the D:P:S.</p> <p>Syntax: SEND_COMMAND <DEV>, "'?AUDIN_GAIN'"</p> <p>Example: SEND_COMMAND AUDIO_INPUT_1, "'?AUDIN_GAIN'"</p> <p>Returns a COMMAND string of the form: AUDIN_GAIN-<gain>.</p>
AUDIN_GAIN	<p>Sets the gain of the audio port addressed by the D:P:S to <gain>.</p> <p>Syntax: SEND_COMMAND <DEV>, "'AUDIN_GAIN-<gain>'"</p> <p>Variable: gain = -24 to 24 in dB</p> <p>Example: SEND_COMMAND AUDIO_INPUT_1, "'AUDIN_GAIN-12'"</p> <p>Sets the gain of the audio input port (#1 based on D:P:S) to 12 dB.</p>
?AUDIN_STEREO	<p>Requests to see if the audio port addressed by the D:P:S has the stereo setting enabled or disabled.</p> <p>Syntax: SEND_COMMAND <DEV>, "'?AUDIN_STEREO'"</p> <p>Example: SEND_COMMAND AUDIO_INPUT_1, "'?AUDIN_STEREO'"</p> <p>Returns a COMMAND string of the form: AUDIN_STEREO-<setting>.</p>

Audio SEND_COMMANDS (Cont.)	
AUDIN_STEREO	<p>Enables or disables the stereo setting on the audio port addressed by the D:P:S. If enabled, the stereo setting is on. If disabled, the stereo setting is off, which means it is mono.</p> <p>Syntax: SEND_COMMAND <DEV>, "'AUDIN_STEREO-<setting>'"</p> <p>Variable: setting = stereo or mono</p> <p>Example: SEND_COMMAND AUDIO_INPUT_1, "'AUDIN_STEREO-stereo'"</p>
?AUDIO_MUTE	See the <i>?AUDOUT_MUTE</i> section on page 97.
AUDIO_MUTE	See the <i>AUDOUT_MUTE</i> section on page 97.
?AUDMIC_COMPRESSION	<p>Requests the setting of compression for a microphone.</p> <p>Syntax: SEND_COMMAND <DEV>, "'?AUDMIC_COMPRESSION'"</p> <p>Example: SEND_COMMAND MICROPHONE_1, "'?AUDMIC_COMPRESSION'"</p> <p>Returns a COMMAND string of the form: AUDMIC_COMPRESSION-<setting>.</p>
AUDMIC_COMPRESSION	<p>Sets the setting of compression of the microphone port addressed by the D:P:S to <setting>.</p> <p>Syntax: SEND_COMMAND <DEV>, "'AUDMIC_COMPRESSION-<setting>'"</p> <p>Variable: setting = off, low, medium, high, custom</p> <p>Example: SEND_COMMAND MICROPHONE_1, "'AUDMIC_COMPRESSION-high'"</p> <p>Sets the compression for the microphone port (#1 based on D:P:S) to high.</p>
?AUDMIC_COMPRESSION_ATTACK	<p>Requests the duration of the attack phase while compressing for a microphone.</p> <p>Syntax: SEND_COMMAND <DEV>, "'?AUDMIC_COMPRESSION_ATTACK'"</p> <p>Example: SEND_COMMAND MICROPHONE_1, "'?AUDMIC_COMPRESSION_ATTACK'"</p> <p>Returns a COMMAND string of the form: AUDMIC_COMPRESSION-ATTACK-<attack>.</p>
AUDMIC_COMPRESSION_ATTACK	<p>Sets the duration of the attack phase while compressing for the microphone port addressed by the D:P:S.</p> <p>Syntax: SEND_COMMAND <DEV>, "'AUDMIC_COMPRESSION_ATTACK-<attack>'"</p> <p>Variable: attack = 1 to 2000</p> <p>Example: SEND_COMMAND MICROPHONE_1, "'AUDMIC_COMPRESSION_ATTACK-200'"</p> <p>Sets the compression attack for the microphone port (#1 based on the D:P:S) to 200.</p>
?AUDMIC_COMPRESSION_RATIO	<p>Requests the ratio while compressing for a microphone.</p> <p>Syntax: SEND_COMMAND <DEV>, "'?AUDMIC_COMPRESSION_RATIO'"</p> <p>Example: SEND_COMMAND MICROPHONE_1, "'?AUDMIC_COMPRESSION_RATIO'"</p> <p>Returns a COMMAND string of the form: AUDMIC_COMPRESSION-RATIO-<ratio>.</p>
AUDMIC_COMPRESSION_RATIO	<p>Sets the ratio while compressing for the microphone port addressed by the D:P:S.</p> <p>Syntax: SEND_COMMAND <DEV>, "'AUDMIC_COMPRESSION_RATIO-<ratio>'"</p> <p>Variable: ratio = 1 to 20</p> <p>Example: SEND_COMMAND MICROPHONE_1, "'AUDMIC_COMPRESSION_RATIO-5'"</p> <p>Sets the compression ratio for the microphone port (#1 based on the D:P:S) to 5.</p>
?AUDMIC_COMPRESSION_RELEASE	<p>Requests the duration of the release phase while compressing for a microphone.</p> <p>Syntax: SEND_COMMAND <DEV>, "'?AUDMIC_COMPRESSION_RELEASE'"</p> <p>Example: SEND_COMMAND MIC_1, "'?AUDMIC_COMPRESSION_RELEASE'"</p> <p>Returns a COMMAND string of the form: AUDMIC_COMPRESSION-RELEASE-<release>.</p>

Audio SEND_COMMANDS (Cont.)	
AUDMIC_COMPRESSION_RELEASE	<p>Sets the duration of the release phase while compressing for the microphone port addressed by the D:P:S.</p> <p>Syntax: SEND_COMMAND <DEV>, "'AUDMIC_COMPRESSION_RELEASE-<release>'"</p> <p>Variable: release = 1 to 5000</p> <p>Example: SEND_COMMAND MICROPHONE_1, "'AUDMIC_COMPRESSION_RELEASE-200'"</p> <p>Sets the compression release for the microphone port (#1 based on the D:P:S) to 200.</p>
?AUDMIC_COMPRESSION_THRESH	<p>Requests the threshold while compressing for a microphone.</p> <p>Syntax: SEND_COMMAND <DEV>, "'?AUDMIC_COMPRESSION_THRESH'"</p> <p>Example: SEND_COMMAND MIC_1, "'?AUDMIC_COMPRESSION_THRESH'"</p> <p>Returns a COMMAND string of the form: AUDMIC_COMPRESSION-THRESH-<thresh>.</p>
AUDMIC_COMPRESSION_THRESH	<p>Sets the threshold while compressing for the microphone port addressed by the D:P:S.</p> <p>Syntax: SEND_COMMAND <DEV>, "'AUDMIC_COMPRESSION_THRESH-<thresh>'"</p> <p>Variable: thresh = 0 to -60</p> <p>Example: SEND_COMMAND MICROPHONE_1, "'AUDMIC_COMPRESSION_THRESH-20'"</p> <p>Sets the compression threshold for the microphone port (#1 based on the D:P:S) to -20.</p>
AUDMIC_DUCK_ATTACK	<p>Sets the duration of the attack phase while ducking for the microphone port addressed by the D:P:S.</p> <p>Syntax: SEND_COMMAND <DEV>, "'AUDMIC_DUCK_ATTACK-<attack>'"</p> <p>Variable: attack = 1 to 2000</p> <p>Example: SEND_COMMAND MICROPHONE_1, "'AUDMIC_DUCK_ATTACK-200'"</p> <p>Sets the ducking attack for the microphone port (#1 based on the D:P:S) to 200.</p>
AUDMIC_DUCK_HOLD	<p>Sets the duration of the hold phase while ducking for the microphone port addressed by the D:P:S.</p> <p>Syntax: SEND_COMMAND <DEV>, "'AUDMIC_DUCK_HOLD-<hold>'"</p> <p>Variable: hold = 0 to 2000</p> <p>Example: SEND_COMMAND MICROPHONE_1, "'AUDMIC_DUCK_HOLD-200'"</p> <p>Sets the ducking hold for the microphone port (#1 based on the D:P:S) to 200.</p>
AUDMIC_DUCK_LEVEL	<p>Sets the level while ducking for the microphone port addressed by the D:P:S.</p> <p>Syntax: SEND_COMMAND <DEV>, "'AUDMIC_DUCK_LEVEL-<level>'"</p> <p>Variable: level = 0 to 20</p> <p>Example: SEND_COMMAND MICROPHONE_1, "'AUDMIC_DUCK_LEVEL-4'"</p> <p>Sets the ducking level for the microphone port (#1 based on the D:P:S) to 4.</p>
AUDMIC_DUCK_RELEASE	<p>Sets the duration of the release phase while ducking from the microphone port addressed by the D:P:S.</p> <p>Syntax: SEND_COMMAND <DEV>, "'AUDMIC_DUCK_RELEASE-<release>'"</p> <p>Variable: release = 10 to 5000</p> <p>Example: SEND_COMMAND MICROPHONE_1, "'AUDMIC_DUCK_RELEASE-200'"</p> <p>Sets the ducking release for the microphone port (#1 based on the D:P:S) to 200.</p>

Audio SEND_COMMANDS (Cont.)	
?AUDMIC_EQ_CF	<p>Requests the frequency for the specified microphone band of the equalizer for the microphone port addressed by the D:P:S.</p> <p>Syntax: SEND_COMMAND <DEV>, "'?AUDMIC_EQ_CF-<band>' "</p> <p>Variables: band = 1..3 on the microphone inputs.</p> <p>Example: SEND_COMMAND MIC_1, "'?AUDMIC_EQ_CF-1' "</p> <p>Returns a COMMAND string of the form: AUDMIC_EQ_CF-<band>,<value>.</p>
AUDMIC_EQ_CF	<p>Sets the frequency for the specified microphone band of the equalizer for the microphone port addressed by the D:P:S.</p> <p>Syntax: SEND_COMMAND <DEV>, "'AUDMIC_EQ_CF-<band>,<frequency>' "</p> <p>Variables: band = 1..3 on the microphone inputs. frequency = 20 to 20,000 in Hz.</p> <p>Example: SEND_COMMAND MICROPHONE_1, "'AUDMIC_EQ_CF-1,1000' "</p> <p>Sets the frequency for the first band of the equalizer for the selected microphone port (#1 based on D:P:S) to be 1000.</p>
?AUDMIC_EQ_FT	<p>Requests the filter type of the specified microphone band of the equalizer for the microphone port addressed by the D:P:S.</p> <p>Syntax: SEND_COMMAND <DEV>, "'?AUDMIC_EQ_FT-<band>' "</p> <p>Variable: band = 1..3 on the microphone inputs.</p> <p>Example: SEND_COMMAND MIC_1, "'?AUDMIC_EQ_FT-1' "</p> <p>Returns a COMMAND string of the form: AUDMIC_EQ_FT-<band>,<value>.</p>
AUDMIC_EQ_FT	<p>Set the filter type of any of the specified microphone band of the equalizer for the microphone port addressed by the D:P:S.</p> <p>Syntax: SEND_COMMAND <DEV>, "'AUDMIC_EQ_FT-<band>,<type>' "</p> <p>Variables: band = 1..3 on the microphone inputs. type = bell, band pass, band stop, high pass, low pass, treble shelf, bass shelf</p> <p>Example: SEND_COMMAND MICROPHONE_1, "'AUDMIC_EQ_FT-1,band pass' "</p> <p>Sets the filter type for the first band of the equalizer for the selected microphone port (#1 based on D:P:S) to band pass.</p>
?AUDMIC_EQ_GAIN	<p>Requests the gain on the microphone equalizer setting of band <band> on the output audio port addressed by the D:P:S.</p> <p>Syntax: SEND_COMMAND <DEV>, "'?AUDMIC_EQ_GAIN-<band>' "</p> <p>Variable: band = 1..3 on the microphone inputs.</p> <p>Example: SEND_COMMAND MIC_1, "'?AUDMIC_EQ_GAIN-1' "</p> <p>Returns a COMMAND string of the form: AUDMIC_EQ_GAIN-<band>,<value>.</p>
AUDMIC_EQ_GAIN	<p>Sets the gain on the microphone equalizer band <band> on the output audio port addressed by the D:P:S to <value>.</p> <p>Syntax: SEND_COMMAND <DEV>, "'AUDMIC_EQ_GAIN-<band>,<value>' "</p> <p>Variables: band = 1..3 on the microphone inputs. value = -12..12. The units are in dB.</p> <p>Example: SEND_COMMAND MIC_1, "'AUDMIC_EQ_GAIN-1,8' "</p> <p>Sets the gain on microphone band #1 of microphone 1 equalizer to 8. SEND_COMMAND MIC_2, "'AUDMIC_EQ_GAIN-3,10' "</p> <p>Sets the gain on microphone band #3 of microphone 2 equalizer to 10.</p>

Audio SEND_COMMANDS (Cont.)	
?AUDMIC_EQ_Q	<p>Requests the quality factor (Q) for the specified microphone band of the equalizer for the microphone port addressed by the D:P:S.</p> <p>Syntax: SEND_COMMAND <DEV>, "'?AUDMIC_EQ_Q-<band>'"</p> <p>Variable: band = 1..3 on the microphone inputs.</p> <p>Example: SEND_COMMAND MIC_1, "'?AUDMIC_EQ_Q-1'"</p> <p>Returns a COMMAND string of the form: AUDMIC_EQ_Q-<band>,<value>.</p>
AUDMIC_EQ_Q	<p>Sets the quality factor (Q) for the specified microphone band of the equalizer for the microphone port addressed by the D:P:S.</p> <p>Syntax: SEND_COMMAND <DEV>, "'AUDMIC_EQ_Q-<band>,<factor>'"</p> <p>Variables: band = 1 to 3 on the microphone inputs. factor = range depends on filter type (set by AUDMIC_EQ_FT) Bell: range is 0.1 - 20.0 Band Pass: range is 0.1 - 20.0 Band Stop: range is 0.1 - 20.0 High Pass: range is 0.5 - 1.4 Low Pass: range is 0.5 - 1.4 Treble Shelf: range is 0.5 - 1.0 Bass Shelf: range is 0.5 - 1.0</p> <p>Example: SEND_COMMAND MICROPHONE_1, "'AUDMIC_Q-1,1'"</p> <p>Sets the quality factor for the first band of the equalizer for the selected microphone port (#1 based on D:P:S) to 1.</p>
?AUDMIC_GAIN	<p>Requests the gain setting for the microphone.</p> <p>Syntax: SEND_COMMAND <DEV>, "'?AUDMIC_GAIN'"</p> <p>Example: SEND_COMMAND MICROPHONE_1, "'?AUDMIC_GAIN'"</p> <p>Returns a COMMAND string of the form: AUDMIC_GAIN-<gain>.</p>
AUDMIC_GAIN	<p>Sets the gain of the microphone port addressed by the D:P:S to <gain>.</p> <p>Syntax: SEND_COMMAND <DEV>, "'AUDMIC_GAIN-<gain>'"</p> <p>Variable: gain = -24 to 24 in dB</p> <p>Example: SEND_COMMAND MICROPHONE_1, "'AUDMIC_GAIN-3'"</p> <p>Sets the gain for the microphone port (#1 based on the D:P:S) to 3dB.</p>
?AUDMIC_GATING	<p>Requests the setting of gating of a microphone.</p> <p>Syntax: SEND_COMMAND <DEV>, "'?AUDMIC_GATING'"</p> <p>Example: SEND_COMMAND MICROPHONE_1, "'?AUDMIC_GATING'"</p> <p>Returns a COMMAND string of the form: AUDMIC_GATING-<setting>.</p>
AUDMIC_GATING	<p>Sets the setting of gating of the microphone port addressed by the D:P:S to <option>.</p> <p>Syntax: SEND_COMMAND <DEV>, "'AUDMIC_GATING-<setting>'"</p> <p>Variable: setting = off, low, medium, high, custom</p> <p>Example: SEND_COMMAND MICROPHONE_1, "'AUDMIC_GATING-low'"</p> <p>Sets the gating for the microphone port (#1 based on D:P:S) to low.</p>
?AUDMIC_GATING_ATTACK	<p>Requests the duration of the attack phase while gating from the microphone port addressed by the D:P:S.</p> <p>Syntax: SEND_COMMAND <DEV>, "'?AUDMIC_GATING_ATTACK'"</p> <p>Example: SEND_COMMAND MIC_1, "'?AUDMIC_GATING_ATTACK'"</p> <p>Returns a string of the form: AUDMIC_GATING_ATTACK=<value>.</p>

Audio SEND_COMMANDS (Cont.)	
AUDMIC_GATING_ATTACK	<p>Sets the duration of the attack phase while gating from the microphone port addressed by the D:P:S.</p> <p>Syntax: SEND_COMMAND <DEV>, "'AUDMIC_GATING_ATTACK-<attack>'"</p> <p>Variable: attack = 1 to 2000</p> <p>Example: SEND_COMMAND MICROPHONE_1, "'AUDMIC_GATING_ATTACK-200'"</p> <p>Sets the gating attack for the microphone port (#1 based on the D:P:S) to 200.</p>
?AUDMIC_GATING_DEPTH	<p>Requests the depth setting while gating from the microphone port addressed by the D:P:S.</p> <p>Syntax: SEND_COMMAND <DEV>, "'?AUDMIC_GATING_DEPTH'"</p> <p>Example: SEND_COMMAND MIC_1, "'?AUDMIC_GATING_DEPTH'"</p> <p>Returns a string of the form: AUDMIC_GATING_DEPTH=<value>.</p>
AUDMIC_GATING_DEPTH	<p>Sets the depth while gating from the microphone port addressed by the D:P:S.</p> <p>Syntax: SEND_COMMAND <DEV>, "'AUDMIC_GATING_DEPTH-<depth>'"</p> <p>Variable: depth = 0 to 20</p> <p>Example: SEND_COMMAND MICROPHONE_1, "'AUDMIC_GATING_DEPTH-8'"</p> <p>Sets the gating depth for the microphone port (#1 based on the D:P:S) to 8.</p>
?AUDMIC_GATING_HOLD	<p>Requests the hold setting while gating from the microphone port addressed by the D:P:S.</p> <p>Syntax: SEND_COMMAND <DEV>, "'?AUDMIC_GATING_HOLD'"</p> <p>Example: SEND_COMMAND MIC_1, "'?AUDMIC_GATING_HOLD'"</p> <p>Returns a string of the form: AUDMIC_GATING_HOLD=<value>.</p>
AUDMIC_GATING_HOLD	<p>Sets the duration of the hold phase while gating for the microphone port addressed by the D:P:S.</p> <p>Syntax: SEND_COMMAND <DEV>, "'AUDMIC_GATING_HOLD-<hold>'"</p> <p>Variable: hold = 0 to 2000</p> <p>Example: SEND_COMMAND MICROPHONE_1, "'AUDMIC_GATING_HOLD-200'"</p> <p>Sets the gating hold for the microphone port (#1 based on the D:P:S) to 200.</p>
?AUDMIC_GATING_RELEASE	<p>Requests the duration of the release phase while gating from the microphone port addressed by the D:P:S.</p> <p>Syntax: SEND_COMMAND <DEV>, "'?AUDMIC_GATING_RELEASE'"</p> <p>Example: SEND_COMMAND MIC_1, "'?AUDMIC_GATING_RELEASE'"</p> <p>Returns a string of the form: AUDMIC_GATING_RELEASE=<value>.</p>
AUDMIC_GATING_RELEASE	<p>Sets the duration of the release phase while gating from the microphone port addressed by the D:P:S.</p> <p>Syntax: SEND_COMMAND <DEV>, "'AUDMIC_GATING_RELEASE-<release>'"</p> <p>Variable: release = 10 to 5000</p> <p>Example: SEND_COMMAND MICROPHONE_1, "'AUDMIC_GATING_RELEASE-200'"</p> <p>Sets the gating release for the microphone port (#1 based on the D:P:S) to 200.</p>
?AUDMIC_GATING_THRESH	<p>Requests the threshold setting while gating from the microphone port addressed by the D:P:S.</p> <p>Syntax: SEND_COMMAND <DEV>, "'?AUDMIC_GATING_THRESH'"</p> <p>Example: SEND_COMMAND MIC_1, "'?AUDMIC_GATING_THRESH'"</p> <p>Returns a string of the form: AUDMIC_GATING_THRESH=<value>.</p>

Audio SEND_COMMANDS (Cont.)	
AUDMIC_GATING_THRESH	<p>Sets the threshold while gating for the microphone port addressed by the D:P:S.</p> <p>Syntax: SEND_COMMAND <DEV>, " 'AUDMIC_GATING_THRESH-<thresh>' "</p> <p>Variable: thresh = 0 to -60</p> <p>Example: SEND_COMMAND MICROPHONE_1, " 'AUDMIC_GATING_THRESH--20' "</p> <p>Sets the gating threshold for the microphone port (#1 based on the D:P:S) to -20.</p>
?AUDMIC_LIMITER	<p>Requests the setting of the limiter of a microphone.</p> <p>Syntax: SEND_COMMAND <DEV>, " '?AUDMIC_LIMITER' "</p> <p>Example: SEND_COMMAND MIC_1, " '?AUDMIC_LIMITER' "</p> <p>Returns a COMMAND string of the form: AUDMIC_LIMITER-<setting>.</p>
AUDMIC_LIMITER	<p>Enables or Disables whether the microphone addressed by D:P:S has the Limiter functionality turned on.</p> <p>Syntax: SEND_COMMAND <DEV>, " 'AUDMIC_LIMITER-<setting>' "</p> <p>Variable: setting = off, low, medium, high, custom</p> <p>Example: SEND_COMMAND MIC_1, " 'AUDMIC_LIMITER-off' "</p> <p>Turns off the limiter for the microphone port (#1 based on D:P:S).</p>
?AUDMIC_LIMITER_ATTACK	<p>Requests the duration of the attack phase while limiting from the microphone port addressed by the D:P:S.</p> <p>Syntax: SEND_COMMAND <DEV>, " '?AUDMIC_LIMITER_ATTACK' "</p> <p>Example: SEND_COMMAND MIC_1, " '?AUDMIC_LIMITER_ATTACK' "</p> <p>Returns a string of the form: AUDMIC_LIMITER_ATTACK=< value>.</p>
AUDMIC_LIMITER_ATTACK	<p>Sets the duration of the attack phase while limiting for the microphone port addressed by the D:P:S.</p> <p>Syntax: SEND_COMMAND <DEV>, " 'AUDMIC_LIMITER_ATTACK-<attack>' "</p> <p>Variable: attack = 1 to 2000</p> <p>Example: SEND_COMMAND MICROPHONE_1, " 'AUDMIC_LIMITER_ATTACK-200' "</p> <p>Sets the limiter attack for the microphone port (#1 based on the D:P:S) to 200.</p>
?AUDMIC_LIMITER_RELEASE	<p>Requests the duration of the release phase while limiting from the microphone port addressed by the D:P:S.</p> <p>Syntax: SEND_COMMAND <DEV>, " '?AUDMIC_LIMITER_RELEASE' "</p> <p>Example: SEND_COMMAND MIC_1, " '?AUDMIC_LIMITER_RELEASE' "</p> <p>Returns a string of the form: AUDMIC_LIMITER_RELEASE=< release>.</p>
AUDMIC_LIMITER_RELEASE	<p>Sets the duration of the release phase while limiting for the microphone port addressed by the D:P:S.</p> <p>Syntax: SEND_COMMAND <DEV>, " 'AUDMIC_LIMITER_RELEASE-<release>' "</p> <p>Variable: release = 10 to 5000</p> <p>Example: SEND_COMMAND MICROPHONE_1, " 'AUDMIC_LIMITER_RELEASE-200' "</p> <p>Sets the limiter release for the microphone port (#1 based on the D:P:S) to 200.</p>
?AUDMIC_LIMITER_THRESH	<p>Requests the duration of the threshold phase while limiting from the microphone port addressed by the D:P:S.</p> <p>Syntax: SEND_COMMAND <DEV>, " '?AUDMIC_LIMITER_THRESH' "</p> <p>Example: SEND_COMMAND MIC_1, " '?AUDMIC_LIMITER_THRESH' "</p> <p>Returns a string of the form: AUDMIC_LIMITER_THRESH=< thresh>.</p>

Audio SEND_COMMANDS (Cont.)	
AUDMIC_LIMITER_THRESH	<p>Sets the threshold while limiting from the microphone for addressed by the D:P:S.</p> <p>Syntax: SEND_COMMAND <DEV>, "'AUDMIC_LIMITER_THRESH-<thresh>'"</p> <p>Variable: thresh = 0 to -60</p> <p>Example: SEND_COMMAND MICROPHONE_1, "'AUDMIC_LIMITER_THRESH--20'"</p> <p>Sets the limiter threshold for the microphone port (#1 based on the D:P:S) to -20.</p>
?AUDMIC_ON	<p>Requests the status of the microphone port addressed by the D:P:S.</p> <p>Syntax: SEND_COMMAND <DEV>, "'?AUDMIC_ON'"</p> <p>Example: SEND_COMMAND MICROPHONE_1, "'?AUDMIC_ON'"</p> <p>Returns a COMMAND string of the form: AUDMIC_ON-<setting>.</p>
AUDMIC_ON	<p>Enables or disables the microphone port addressed by the D:P:S.</p> <p>Syntax: SEND_COMMAND <DEV>, "'AUDMIC_ON-<setting>'"</p> <p>Variable: setting = on, off</p> <p>Example: SEND_COMMAND MICROPHONE_1, "'AUDMIC_ON-off'"</p> <p>Disables the microphone port (#1 based on the D:P:S).</p>
?AUDMIC_PHANTOM_PWR	<p>Requests the setting for phantom power for a microphone.</p> <p>Syntax: SEND_COMMAND <DEV>, "'?AUDMIC_PHANTOM_PWR'"</p> <p>Example: SEND_COMMAND MICROPHONE_1, "'?AUDMIC_PHANTOM_PWR'"</p> <p>Returns a COMMAND string of the form: AUDMIC_PHANTOM_PWR-<result>.</p>
AUDMIC_PHANTOM_PWR	<p>Enables or disables phantom power for the microphone port addressed by the D:P:S.</p> <p>Syntax: SEND_COMMAND <DEV>, "'AUDMIC_PHANTOM_PWR-<setting>'"</p> <p>Variable: setting = on, off</p> <p>Example: SEND_COMMAND MICROPHONE_1, "'AUDMIC_PHANTOM_PWR-on'"</p> <p>Allows phantom power for the microphone port (#1 based on D:P:S).</p>
?AUDMIC_PREAMP_GAIN	<p>Requests the gain of the microphone before the amplifier.</p> <p>Syntax: SEND_COMMAND <DEV>, "'?AUDMIC_PREAMP_GAIN'"</p> <p>Example: SEND_COMMAND MIC_1, "'?AUDMIC_PREAMP_GAIN'"</p> <p>Returns a COMMAND string of the form: AUDMIC_PREAMP_GAIN-<gain>.</p>
AUDMIC_PREAMP_GAIN	<p>Sets the pre-amplifier gain of the microphone addressed by the D:P:S to <value>.</p> <p>Syntax: SEND_COMMAND <DEV>, "'AUDMIC_PREAMP_GAIN-<gain>'"</p> <p>Variables: gain = 0-100. The units are in %.</p> <p>Example: SEND_COMMAND MIC_1, "'AUDMIC_PREAMP_GAIN-50'"</p> <p>Sets the pre-amplifier gain for the microphone port (#1 based on D:P:S) to 50%.</p>
?AUDMIC_STEREO	<p>Requests the microphone port(s) that is/are in use.</p> <p>Syntax: SEND_COMMAND <DEV>, "'?AUDMIC_STEREO'"</p> <p>Example: SEND_COMMAND MICROPHONE_1, "'?AUDMIC_STEREO'"</p> <p>Returns a COMMAND string of the form: AUDMIC_STEREO-<option>.</p>

Audio SEND_COMMANDS (Cont.)	
AUDMIC_STEREO	<p>Sets which microphone port addressed by the D:P:S to use.</p> <p>Syntax: SEND_COMMAND <DEV>, "'AUDMIC_STEREO-<option>'"</p> <p>Variable: option = "dual mono" or "single stereo"</p> <p>Example: SEND_COMMAND MIC_1, "'AUDMIC_STEREO-single stereo'"</p> <p>Sets the microphone port (#1 based on the D:P:S) to use both the microphone inputs as dual mono.</p>
?AUDOUT_BALANCE	<p>Request the current balance setting for the audio port addressed by the D:P:S.</p> <p>Syntax: SEND_COMMAND <DEV>, "'?AUDOUT_BALANCE'"</p> <p>Example: SEND_COMMAND AUDIO_OUTPUT_1, "'?AUDOUT_BALANCE'"</p> <p>Returns a COMMAND string of the form: AUDOUT_BALANCE-<balance>.</p>
AUDOUT_BALANCE	<p>Sets the left and right balance for the audio port addressed by the D:P:S.</p> <p>Syntax: SEND_COMMAND <DEV>, "'AUDOUT_BALANCE-<balance>'"</p> <p>Variable: balance = -20 to 20 in dB.</p> <p>Example: SEND_COMMAND AUDIO_OUTPUT_1, "'AUDOUT_BALANCE-5'"</p> <p>Sets the balance to favor the right speaker for audio output port (#1 based on D:P:S) 5dB.</p>
?AUDOUT_DELAY	<p>Requests the current delay for the audio port addressed by the D:P:S.</p> <p>Syntax: SEND_COMMAND <DEV>, "'?AUDOUT_DELAY'"</p> <p>Example: SEND_COMMAND AUDIO_OUTPUT_1, "'?AUDOUT_DELAY'"</p> <p>Returns a COMMAND string of the form: AUDOUT_DELAY-<delay>.</p>
AUDOUT_DELAY	<p>Sets the delay in regards to the input for the audio port addressed by the D:P:S.</p> <p>Syntax: SEND_COMMAND <DEV>, "'AUDOUT_DELAY-<delay>'"</p> <p>Variable: delay = 0 to 200 in milliseconds</p> <p>Example: SEND_COMMAND AUDIO_OUTPUT_1, "'AUDOUT_DELAY-50'"</p> <p>Sets the delay for the audio output port (#1 based on D:P:S) to 50.</p>
AUDOUT_DUCK_ATTACK	<p>Sets the duration of the attack phase while ducking for the output port addressed by the D:P:S.</p> <p>Syntax: SEND_COMMAND <DEV>, "'AUDOUT_DUCK_ATTACK-<attack>'"</p> <p>Variable: attack = 1 to 2000</p> <p>Example: SEND_COMMAND AUDIO_OUTPUT_1, "'AUDOUT_DUCK_ATTACK-200'"</p> <p>Sets the ducking attack for the output port (#1 based on the D:P:S) to 200.</p>
AUDOUT_DUCK_HOLD	<p>Sets the duration of the hold phase while ducking for the output port addressed by the D:P:S.</p> <p>Syntax: SEND_COMMAND <DEV>, "'AUDOUT_DUCK_HOLD-<hold>'"</p> <p>Variable: hold = 0 to 2000</p> <p>Example: SEND_COMMAND AUDIO_OUTPUT_1, "'AUDOUT_DUCK_HOLD-200'"</p> <p>Sets the ducking hold for the output port (#1 based on the D:P:S) to 200.</p>
AUDOUT_DUCK_LEVEL	<p>Sets the level while ducking for the output port addressed by the D:P:S.</p> <p>Syntax: SEND_COMMAND <DEV>, "'AUDOUT_DUCK_LEVEL-<level>'"</p> <p>Variable: level = 0 to 20</p> <p>Example: SEND_COMMAND AUDIO_OUTPUT_1, "'AUDOUT_DUCK_LEVEL-4'"</p> <p>Sets the ducking level for the output port (#1 based on the D:P:S) to 4.</p>

Audio SEND_COMMANDS (Cont.)	
AUDOUT_DUCK_RELEASE	<p>Sets the duration of the release phase while ducking from the output port addressed by the D:P:S.</p> <p>Syntax: SEND_COMMAND <DEV>, "AUDOUT_DUCK_RELEASE-<release>"</p> <p>Variable: release = 10 to 5000</p> <p>Example: SEND_COMMAND AUDIO_OUTPUT_1, "AUDOUT_DUCK_RELEASE-200" Sets the ducking release for the output port (#1 based on the D:P:S) to 200.</p>
?AUDOUT_DUCK_THRESH	<p>Requests the current ducking thresholds of both microphone ports for the audio port addressed by the D:P:S.</p> <p>Syntax: SEND_COMMAND <DEV>, "?AUDOUT_DUCK_THRESH"</p> <p>Example: SEND_COMMAND AUDIO_OUTPUT_1, "?AUDOUT_DUCK_THRESH" Returns a COMMAND string of the form: AUDOUT_DUCK_THRESH-<mic1_thresh>,<mic2_thresh>.</p>
AUDOUT_DUCK_THRESH	<p>Individually sets the ducking thresholds of both microphone ports for the audio port addressed by the D:P:S.</p> <p>Syntax: SEND_COMMAND <DEV>, "AUDOUT_DUCK_THRESH-<mic1_thresh>"</p> <p>Variables: mic1_thresh = -60 to 0</p> <p>Example: SEND_COMMAND AUDIO_OUTPUT_1, "AUDOUT_DUCK_THRESH--12" Sets the two microphone thresholds for the audio output port (#1 based on D:P:S) to -12.</p>
?AUDOUT_DUCKING	<p>Requests the current setting of ducking for the audio port addressed by the D:P:S.</p> <p>Syntax: SEND_COMMAND <DEV>, "?AUDOUT_DUCKING"</p> <p>Example: SEND_COMMAND AUDIO_OUTPUT_1, "?AUDOUT_DUCKING" Returns a COMMAND string of the form: AUDOUT_DUCKING-<setting>.</p>
AUDOUT_DUCKING	<p>Sets the setting of ducking for the audio port addressed by the D:P:S.</p> <p>Syntax: SEND_COMMAND <DEV>, "AUDOUT_DUCKING-<setting>"</p> <p>Variable: setting = off, low, medium, high, custom</p> <p>Example: SEND_COMMAND AUDIO_OUTPUT_1, "AUDOUT_DUCKING-low" Sets the ducking for the audio output port (#1 based on D:P:S) to low.</p>
?AUDOUT_EQ_CF	<p>Requests the center frequency on the equalizer setting of band <band> on the output audio port addressed by the D:P:S.</p> <p>Syntax: SEND_COMMAND <DEV>, "?AUDOUT_EQ_CF-<band>"</p> <p>Example: SEND_COMMAND AUDIO_OUTPUT_1, "?AUDOUT_EQ_CF-1" Returns a COMMAND string of the form: AUDOUT_EQ_CF-<band>,<value>.</p>
AUDOUT_EQ_CF	<p>Sets the center frequency on the equalizer band <band> on the output audio port addressed by the D:P:S to <value>.</p> <p>Syntax: SEND_COMMAND <DEV>, "AUDOUT_EQ_CF-<band>,<value>"</p> <p>Variables: band = 1..10 if on the audio output port. value = 20..20000. The units are in Hz.</p> <p>Example: SEND_COMMAND AUDIO_OUTPUT_1, "AUDOUT_EQ_CF-1=80" Sets the center frequency on band #1 of audio port 1 equalizer to 80. SEND_COMMAND AUDIO_OUTPUT_2, "AUDOUT_EQ_CF-5=100" Sets the center frequency on band #5 of audio port 2 equalizer to 100.</p>
?AUDOUT_EQ_FT	<p>Requests the filter type on a specific setting of band <band> on the output audio port addressed by the D:P:S.</p> <p>Syntax: SEND_COMMAND <DEV>, "?AUDOUT_EQ_FT-<band>"</p> <p>Example: SEND_COMMAND AUDIO_OUTPUT_1, "?AUDOUT_EQ_FT-1" Returns a COMMAND string of the form: AUDOUT_EQ_FT-<band>,<filter>.</p>

Audio SEND_COMMANDS (Cont.)	
AUDOUT_EQ_FT	<p>Sets the filter type on the equalizer band <band> on the output audio port addressed by the D:P:S to <filter type>.</p> <p>Syntax: SEND_COMMAND <DEV>, "'AUDOUT_EQ_FT-<band>=<filter type>'"</p> <p>Variables: band = 1..10 if on the audio output port. filter type = Bell, Band Pass, Band Stop, High Pass, Low Pass, Treble Shelf, and Bass Shelf</p> <p>Example: SEND_COMMAND AUDIO_OUTPUT_1, "'AUDOUT_EQ_FT-1=Low Pass'"</p> <p>Sets the filter type on band #1 of audio port 1 equalizer to Low Pass.</p>
?AUDOUT_EQ_GAIN	<p>Requests the gain on the equalizer setting of band <band> on the output audio port addressed by the D:P:S.</p> <p>Syntax: SEND_COMMAND <DEV>, "'?AUDOUT_EQ_GAIN-<band>'"</p> <p>Example: SEND_COMMAND AUDIO_OUTPUT_1, "'?AUDOUT_EQ_GAIN-1'"</p> <p>Returns a COMMAND string of the form: AUDOUT_EQ_GAIN-<band>,<value>.</p>
AUDOUT_EQ_GAIN	<p>Sets the gain on the equalizer band <band> on the output audio port addressed by the D:P:S to <value>.</p> <p>Syntax: SEND_COMMAND <DEV>, "'AUDOUT_EQ_GAIN-<band>,<value>'"</p> <p>Variables: band = 1..10 if on the audio output port. value = -12..12. The units are in dB.</p> <p>Example: SEND_COMMAND AUDIO_OUTPUT_1, "'AUDOUT_EQ_GAIN-1=8'"</p> <p>Sets the gain on band #1 of audio port 1 equalizer to 8. SEND_COMMAND AUDIO_OUTPUT_2, "'AUDOUT_EQ_GAIN-5=-10'"</p> <p>Sets the gain on band #5 of audio port 2 equalizer to -10.</p>
?AUDOUT_EQ_MODE	<p>Request the current mode of the equalizer for the audio port addressed by the D:P:S.</p> <p>Syntax: SEND_COMMAND <DEV>, "'?AUDOUT_EQ_MODE'"</p> <p>Example: SEND_COMMAND AUDIO_OUTPUT_1, "'?AUDOUT_EQ_MODE'"</p> <p>Returns a COMMAND string of the form: AUDOUT_EQ_MODE-<mode>.</p>
AUDOUT_EQ_MODE	<p>Sets the mode for the equalizer for the audio port addressed by the D:P:S.</p> <p>Syntax: SEND_COMMAND <DEV>, "'AUDOUT_EQ_MODE-<mode>'"</p> <p>Variables: mode = off, voice, music, movie</p> <p>Example: SEND_COMMAND AUDIO_OUTPUT_1, "'AUDOUT_EQ_MODE-movie'"</p> <p>Sets the equalizer to favor the sounds of a movie for the audio output port (#1 based on D:P:S).</p>
?AUDOUT_EQ_Q	<p>Requests the quality factor (Q) on the equalizer setting of band <band> on the output audio port addressed by the D:P:S.</p> <p>Syntax: SEND_COMMAND <DEV>, "'?AUDOUT_EQ_Q-<band>'"</p> <p>Example: SEND_COMMAND AUDIO_OUTPUT_1, "'?AUDOUT_EQ_Q-1'"</p> <p>Returns a COMMAND string of the form: AUDOUT_EQ_Q-<band>,<factor>.</p>

Audio SEND_COMMANDS (Cont.)	
AUDOUT_EQ_Q	<p>Sets the quality factor (Q) on the equalizer band <band> on the output audio port addressed by the D:P:S to <value>.</p> <p>Syntax: SEND_COMMAND <DEV>, "'AUDOUT_EQ_Q-<band>=<factor>'"</p> <p>Variables: band = 1-10 if on the audio output port. factor = range depends on filter type (AUDOUT_EQ_FT) Bell: range is 0.1 - 20.0 Band Pass: range is 0.1 - 20.0 Band Stop: range is 0.1 - 20.0 High Pass: range is 0.5 - 1.4 Low Pass: range is 0.5 - 1.4 Treble Shelf: range is 0.5 - 1.0 Bass Shelf: range is 0.5 - 1.0</p> <p>Example: SEND_COMMAND AUDIO_OUTPUT_1, "'AUDOUT_EQ_Q-1=8'" Sets the Q on band #1 of the audio port 1 equalizer to 8.</p>
?AUDOUT_MAXVOL	<p>Requests the current maximum volume for the audio port addressed by the D:P:S.</p> <p>Syntax: SEND_COMMAND <DEV>, "'?AUDOUT_MAXVOL'"</p> <p>Example: SEND_COMMAND AUDIO_OUTPUT_1, "'?AUDOUT_MAXVOL'" Returns a COMMAND string of the form: AUDOUT_MAXVOL-<maximum>.</p>
AUDOUT_MAXVOL	<p>Sets the maximum volume for the audio port addressed by the D:P:S.</p> <p>Syntax: SEND_COMMAND <DEV>, "'AUDOUT_MAXVOL-<maximum>'"</p> <p>Variable: maximum = 0 to 100 in percent</p> <p>Example: SEND_COMMAND AUDIO_OUTPUT_1, "'AUDOUT_MAXVOL-75'" Sets the maximum for the audio output port (#1 based on D:P:S) to 75%.</p>
?AUDOUT_MINVOL	<p>Requests the current minimum volume for the audio port addressed by the D:P:S.</p> <p>Syntax: SEND_COMMAND <DEV>, "'?AUDOUT_MINVOL'"</p> <p>Example: SEND_COMMAND AUDIO_OUTPUT_1, "'?AUDOUT_MINVOL'" Returns a COMMAND string of the form: AUDOUT_MINVOL-<minimum>.</p>
AUDOUT_MINVOL	<p>Sets the minimum volume for the audio port addressed by the D:P:S.</p> <p>Syntax: SEND_COMMAND <DEV>, "'AUDOUT_MINVOL-<minimum>'"</p> <p>Variable: minimum = 0 to 100 in percent.</p> <p>Example: SEND_COMMAND AUDIO_OUTPUT_1, "'AUDOUT_MINVOL-5'" Sets the minimum for the audio output port (#1 based on D:P:S) to 5%.</p>
?AUDOUT_MUTE	<p>Requests if the audio port addressed by the D:P:S is muted.</p> <p>Syntax: SEND_COMMAND <DEV>, "'?AUDOUT_MUTE'"</p> <p>Example: SEND_COMMAND dxDev, "'?AUDOUT_MUTE'" Returns a COMMAND string of the form: AUDOUT_MUTE-<enable disable>.</p>
AUDOUT_MUTE	<p>Enable or disable audio muting on the audio port addressed by the D:P:S.</p> <p>Syntax: SEND_COMMAND <DEV>, "'AUDOUT_MUTE-<setting>'"</p> <p>Variables: setting = desired mute state, either ENABLE or DISABLE</p> <p>Example: SEND_COMMAND dxDev, "'AUDOUT_MUTE-DISABLE'"</p>

Audio SEND_COMMANDS (Cont.)	
AUDOUT_RESET_EQ	Resets all EQ levels to 0 for the audio port addressed by the D:P:S. You can optionally reset the EQ for an audio output channel by supplying the channel number. Syntax: SEND_COMMAND <device>, "'AUDOUT_RESET_EQ-<channel>'" Variables: channel = The audio output's channel number. (This setting is optional.) Example: SEND_COMMAND dxDev, "'AUDOUT_RESET_EQ-1'"
?AUDOUT_STEREO	Device responds with "AUDOUT_STEREO-<setting>" where setting is "ENABLE" or "DISABLE". Syntax: SEND_COMMAND <device>, "'?AUDOUT_STEREO'" Example: SEND_COMMAND dxDev, "'?AUDOUT_STEREO'"
AUDOUT_STEREO	Enables or disables audio amp output in stereo. Syntax: SEND_COMMAND <device>, "'AUDOUT_STEREO-<setting>'" Variables: setting = Stereo setting, either "ENABLE" or "DISABLE" Example: SEND_COMMAND dxDev, "'AUDOUT_STEREO-ENABLE'"
?AUDOUT_TESTTONE	Requests the current frequency of test tone for the audio port addressed by the D:P:S. Syntax: SEND_COMMAND <DEV>, "'?AUDOUT_TESTTONE'" Example: SEND_COMMAND AUDIO_OUTPUT_1, "'?AUDOUT_TESTTONE'" Returns a COMMAND string of the form: AUDOUT_TESTTONE-<frequency>.
AUDOUT_TESTTONE	Sets the frequency, if any, of a test tone for the audio port addressed by the D:P:S. Syntax: SEND_COMMAND <DEV>, "'AUDOUT_TESTTONE-<frequency>'" Variable: frequency = off, 60Hz, 250Hz, 400Hz, 1KHz, 3KHz, 5KHz, 10KHz, PINK NOISE, WHITE NOISE Example: SEND_COMMAND AUDIO_OUTPUT_1, "'AUDOUT_TESTTONE-250Hz'" Sets a test tone of 250Hz to play for the audio output port (#1 based on D:P:S).
?AUDOUT_VOLUME	Requests the volume setting of the audio output port addressed by the D:P:S. Syntax: SEND_COMMAND <DEV>, "'?AUDOUT_VOLUME'" Example: SEND_COMMAND AUDOUT_VOLUME_1, "'?AUDOUT_VOLUME'" Returns a COMMAND string of the form: AUDOUT_VOLUME-<value>.
AUDOUT_VOLUME	Sets the volume on the audio output addressed by the D:P:S to <value>. Syntax: SEND_COMMAND <DEV>, "'AUDOUT_VOLUME-<VALUE>'" Variable: value = 0..100 Example: SEND_COMMAND AUDOUT_VOLUME_1, "'AUDOUT_VOLUME-50'" Sets the volume of audio output port #1 to 50.
?GAIN	See the <i>?AUDIN_GAIN</i> section on page 86.
GAIN	See the <i>AUDIN_GAIN</i> section on page 86.
?HDMIOUT_AUDIO	Requests which HDMI output port is currently followed by the audio port addressed by the D:P:S. Syntax: SEND_COMMAND <DEV>, "'?HDMIOUT_AUDIO'" Example: SEND_COMMAND AUDIO_OUTPUT_1, "'?HDMIOUT_AUDIO'" Returns a COMMAND string of the form: HDMIOUT_AUDIO-<option>.

Audio SEND_COMMANDS (Cont.)	
HDMIOUT_AUDIO	<p>Determines which output the HDMI output port addressed by the D:P:S will use.</p> <p>Syntax: SEND_COMMAND <DEV>, "'HDMIOUT_AUDIO-<option>'"</p> <p>Variable: option = off, input pass-thru, analog out 1, analog out 2, analog out 3, analog out 4</p> <p>Example: SEND_COMMAND AUDIO_OUTPUT_1, "'HDMIOUT_AUDIO-input pass-thru'"</p> <p>Sets the audio output port (#1 based on D:P:S) to use the audio associated with the HDMI source.</p>
?HDMIOUT_EQ	<p>Requests the current status of the HDMI equalizer for the audio port addressed by the D:P:S.</p> <p>Syntax: SEND_COMMAND <DEV>, "'?HDMIOUT_EQ'"</p> <p>Example: SEND_COMMAND AUDIO_OUTPUT_1, "'?HDMIOUT_EQ'"</p> <p>Returns a COMMAND string of the form: HDMIOUT_EQ-<option>.</p>
HDMIOUT_EQ	<p>Enables or disables the HDMI equalizer for the audio port addressed by the D:P:S.</p> <p>Syntax: SEND_COMMAND <DEV>, "'HDMIOUT_EQ-<option>'"</p> <p>Variable: option = off, on</p> <p>Example: SEND_COMMAND AUDIO_OUTPUT_1, "'HDMIOUT_EQ-on'"</p> <p>Turns on the HDMI output equalizer for the audio output port (#1 based on D:P:S).</p>
?INPUTEQ	See the <i>?AUDMIC_EQ_GAIN</i> section on page 89.
INPUTEQ	See the <i>AUDMIC_EQ_GAIN</i> section on page 89.
?PHANTOM_PWR	See the <i>?AUDMIC_PHANTOM_PWR</i> section on page 93.
PHANTOM_PWR	See the <i>AUDMIC_PHANTOM_PWR</i> section on page 93.
?SPDIFOUT_AUDIO	<p>Requests to which output the audio port addressed by the D:P:S is connected.</p> <p>Syntax: SEND_COMMAND <DEV>, "'?SPDIFOUT_AUDIO'"</p> <p>Example: SEND_COMMAND AUDIO_OUTPUT_1, "'?SPDIFOUT_AUDIO'"</p> <p>Returns a COMMAND string of the form: SPDIFOUT_AUDIO-<option>.</p>
SPDIFOUT_AUDIO	<p>Selects which output the audio port should connect to.</p> <p>Syntax: SEND_COMMAND <DEV>, "'SPDIFOUT_AUDIO-<option>'"</p> <p>Variable: option = off, HDMI out 1, HDMI out 2, HDMI out 3, HDMI out 4, analog out 1, analog out 2, analog out 3, analog out 4</p> <p>Example: SEND_COMMAND AUDIO_OUTPUT_1, "'SPDIFOUT_AUDIO-HDMI out 1'"</p> <p>Sets the audio of HDMI out 1 to play through the audio output port (#1 based on D:P:S).</p>
?VOLUME	See the <i>?AUDOUT_VOLUME</i> section on page 98.
VOLUME	See the <i>AUDOUT_VOLUME</i> section on page 98.
?XPOINT	<p>Requests the mix level contribution of the audio input port addressed by <input> to the audio output mixer addressed by <output>.</p> <p>Syntax: SEND_COMMAND <DEV>, "'?XPOINT-<input>,<output>'"</p> <p>Variables: input = 1, 2, 3 where 1=LINE, 2=Mic1, and 3=Mic2 output = 1..4 where 1 is for the AMP output and 2, 3, and 4 are for the LINEOUT output.</p> <p>Example: SEND_COMMAND AUDIO_OUTPUT_2, "'?XPOINT-1,2'"</p> <p>Returns a COMMAND string of the form: XPOINT-<value>,<input>,<output>.</p>

Audio SEND_COMMANDS (Cont.)	
XPOINT	<p>Sets the mix level that the audio input addressed by the parameter <input> provides to the audio output <output> to <value>.</p> <p>Note: Audio input ports 1..10 share a setting across them for a specific output mixer's value.</p> <p>Syntax: SEND_COMMAND <DEV>, " 'XPOINT-<value>,<input>,<output>' "</p> <p>Variables: value = -100..0 input = 1, 2, 3 where 1=Selected audio input, 2=Mic1, and 3=Mic2 output = 1..4 where 1 is for the AMP output and 2, 3, and 4 are for the LINEOUT 2-4 outputs.</p> <p>Example: SEND_COMMAND AUDIO_OUTPUT_2, " 'XPOINT--75,LINE,2' "</p> <p>Sets the mix level of the selected input's contribution to the audio LINEOUT (2) output to -75.</p>

Video SEND_COMMANDS

The following table lists the video SEND_COMMANDS available for the DVX:

Video SEND_COMMANDS	
CI<input>O<output>	<p>Switches both the audio and video input to the output port.</p> <p>Syntax: SEND_COMMAND <DEV>, " 'CI<input>O<output>' "</p> <p>Variables: input = The source input port number. output = The output port number to switch to.</p> <p>Examples: SEND_COMMAND SWITCHER, " 'CI2O1' " Switch (audio/video) input port #2 to output #1. SEND_COMMAND SWITCHER, " 'CI4O2' " Switch video input port #4 to video output #2. Also switches audio input port #4 to audio output port #2. SEND_COMMAND SWITCHER, " 'CI3O1,2' " Switches video input port #3 to output video ports #1 and #2. Switches audio input port #3 to audio output port #1 and #2.</p>
CL<sl>I<input>O<output>	<p>Switches the audio or video (or both) inputs to the output port.</p> <p>Syntax: SEND_COMMAND <DEV>, " 'CL<sl>I<input>O<output>' "</p> <p>Variables: sl = AUDIO or VIDEO or ALL. ALL = both AUDIO and VIDEO. input = The source input port number. output = The output port number to switch to.</p> <p>Examples: SEND_COMMAND SWITCHER, " 'CLALLI2O1' " Switch audio and video inputs (port #2) to output #1. SEND_COMMAND SWITCHER, " 'CLVIDEOI3O1,2' " Switch video input (port #3) to video output ports #1 and #2. SEND_COMMAND SWITCHER, " 'CLAUDIOI4O1' " Switch audio input (port #4) to audio output port #1. SEND_COMMAND SWITCHER, " 'CLALLI1O1,2' " Switches video input (port #1) to video output ports #1 and #2. Switches audio input (port #1) to audio output port #1.</p>
?INPUT	<p>Normally, if the output port is not connected to any input port then the reply will indicate this with an input port number of ZERO (0). For the DVX products, at this time, the output parameter is ignored and assumed to be 1.</p> <p>Syntax: SEND_COMMAND <DEV>, " '?INPUT-<sl>,<output>' "</p> <p>Variables: sl = AUDIO or VIDEO. output = The output port number.</p> <p>Example: SEND_COMMAND SWITCHER, " '?INPUT-AUDIO,1' "</p> <p>Think of it as asking: Which audio input port is connected to output port #1? Returns a COMMAND string of the form: SWITCH-L<AUDIO VIDEO>I<input>O<output>.</p>
?OSD	See the <i>?VIDOUT_OSD</i> on page 108.
OSD	See the <i>VIDOUT_OSD</i> on page 108.

Video SEND_COMMANDS (Cont.)	
?OUTPUT	<p>If the input port is not connected to any output port then the reply will indicate this with an output port number of ZERO (0).</p> <p>Syntax: SEND_COMMAND <DEV>, "'?OUTPUT-<sl>,<input>' "</p> <p>Variables: sl = AUDIO, VIDEO, or ALL. ALL = both AUDIO -and- VIDEO. input = The source input port number.</p> <p>Example: SEND_COMMAND SWITCHER, "'?OUTPUT-AUDIO,1' "</p> <p>Think of it as asking: Which audio output ports are connected to input port #1? Returns a COMMAND string of the form: SWITCH-L<AUDIO VIDEO>I<input>O<output>.</p>
VI<input>O<output>	<p>Switch input to one or more outputs for switcher level Video. Set <input> to 0 for disconnect.</p> <p>Syntax: SEND_COMMAND <DEV>, "'VI<input>O<output>' "</p> <p>Variables: input = The source video input port number. output = The video output port number to switch to.</p> <p>Example: SEND_COMMAND SWITCHER, "'VI2O1' "</p> <p>Switch video input port #2 to video output #1. SEND_COMMAND SWITCHER, "'VI3O1,2' "</p> <p>Switch video input port #3 to video output ports #1 (DVI) and #2 (RGB).</p>
?VIDEO_MUTE	See the <i>?VIDOUT_MUTE</i> section on page 107.
VIDEO_MUTE	See the <i>VIDOUT_MUTE</i> section on page 107.
?VIDEO_TESTPATTERN	See the <i>?VIDOUT_TESTPAT</i> section on page 109.
VIDEO_TESTPATTERN	See the <i>VIDOUT_TESTPAT</i> section on page 109.
?VIDIN_BRIGHTNESS	<p>Requests the input brightness of the video port addressed by the D:P:S.</p> <p>Syntax: SEND_COMMAND <DEV>, "'?VIDIN_BRIGHTNESS' "</p> <p>Example: SEND_COMMAND VIDEO_INPUT_1, "'?VIDIN_BRIGHTNESS' "</p> <p>Returns a COMMAND string of the form: VIDIN_BRIGHTNESS-<value>.</p>
VIDIN_BRIGHTNESS	<p>Sets the input brightness of the video port addressed by the D:P:S to <value>.</p> <p>Syntax: SEND_COMMAND <DEV>, "'VIDIN_BRIGHTNESS-<value>' "</p> <p>Variables: value = 0..100</p> <p>Example: SEND_COMMAND VIDEO_INPUT_1, "'VIDIN_BRIGHTNESS-50' "</p> <p>Sets the brightness of video input port (#1 based on D:P:S) to 50.</p>
?VIDIN_BW	<p>Requests to see if the video port addressed by the D:P:S has the COLOR setting enabled or disabled.</p> <p>Syntax: SEND_COMMAND <DEV>, "'?VIDIN_BW' "</p> <p>Example: SEND_COMMAND SWITCHER, "'?VIDIN_BW' "</p> <p>Returns a COMMAND string of the form: VIDIN_BW-<ENABLE DISABLE>.</p>
VIDIN_BW	<p>Enables or disables the COLOR setting on the video port addressed by the D:P:S. If enabled, then the COLOR setting is true. If disabled, then the COLOR setting is false which means it's Black & White instead.</p> <p>Syntax: SEND_COMMAND <DEV>, "'VIDIN_BW-<ENABLE DISABLE>' "</p> <p>Example: SEND_COMMAND VIDEO_INPUT_1, "'VIDIN_BW-ENABLE' "</p>
?VIDIN_COLOR	See the <i>?VIDIN_BW</i> on page 101 for more information.
VIDIN_COLOR	See the <i>VIDIN_BW</i> on page 101 for more information.
?VIDIN_CONTRAST	<p>Requests the input contrast of the video port addressed by the D:P:S.</p> <p>Syntax: SEND_COMMAND <DEV>, "'?VIDIN_CONTRAST' "</p> <p>Example: SEND_COMMAND VIDEO_INPUT_1, "'?VIDIN_CONTRAST' "</p> <p>Returns a COMMAND string of the form: VIDIN_CONTRAST-<value>.</p>

Video SEND_COMMANDs (Cont.)	
VIDIN_CONTRAST	<p>Sets the input contrast of the video port addressed by the D:P:S to <value>.</p> <p>Syntax: SEND_COMMAND <DEV>, "'VIDIN_CONTRAST-<value>'"</p> <p>Variables: value = 0..100</p> <p>Example: SEND_COMMAND VIDEO_INPUT_1, "'VIDIN_CONTRAST-50'"</p> <p>Sets the contrast of video input port (#1 based on D:P:S) to 50.</p>
?VIDIN_EDID	<p>Requests the EDID source being mirrored by the video port addressed by the D:P:S.</p> <p>Syntax: SEND_COMMAND <DEV>, "'?VIDIN_EDID'"</p> <p>Example: SEND_COMMAND VIDEO_INPUT_1, "'?VIDIN_EDID'"</p> <p>Returns a COMMAND string of the form: VIDIN_EDID-<source>. See the VIDIN_EDID command for the list of potential sources.</p>
VIDIN_EDID	<p>Sets the EDID source to mirror in video input port addressed by D:P:S.</p> <p>Syntax: SEND_COMMAND <DEV>, "'VIDIN_EDID-<source>'"</p> <p>Variables: source = All Resolutions, Wide-screen, Full-screen, Mirror Out 1, Mirror Out 2, Mirror Out 3, Mirror Out 4</p> <p>Example: SEND_COMMAND VIDEO_INPUT_1, "'VIDIN_EDID-MIRROR OUT 2'"</p>
?VIDIN_EDID_AUTO	<p>Requests whether the EDID source for the video input updates the available list of resolutions at regular intervals.</p> <p>Syntax: SEND_COMMAND <DEV>, "'?VIDIN_EDID_AUTO'"</p> <p>Example: SEND_COMMAND VIDEO_INPUT_1, "'?VIDIN_EDID_AUTO'"</p> <p>Returns a COMMAND string of the form: VIDIN_EDID_AUTO-<status>.</p>
VIDIN_EDID_AUTO	<p>Sets whether you want the EDID source for the video input to update the list of available resolutions at regular intervals.</p> <p>Syntax: SEND_COMMAND <DEV>, "'VIDIN_EDID_AUTO-<ENABLE DISABLE>'"</p> <p>Example: SEND_COMMAND VIDEO_INPUT_1, "'VIDIN_EDID_AUTO-ENABLE'"</p>
?VIDIN_FORMAT	<p>Requests the input format of the video port addressed by the D:P:S.</p> <p>Syntax: SEND_COMMAND <DEV>, "'?VIDIN_FORMAT'"</p> <p>Example: SEND_COMMAND VIDEO_INPUT_1, "'?VIDIN_FORMAT'"</p> <p>Returns a COMMAND string of the form: VIDIN_FORMAT-<format>.</p>
VIDIN_FORMAT	<p>Sets the input format of the video port addressed by the D:P:S to <format>.</p> <p>Syntax: SEND_COMMAND <DEV>, "'VIDIN_FORMAT-<format>'"</p> <p>Variables: format = HDMI, DVI, S-VIDEO, COMPONENT, COMPOSITE, VGA for Multi-Format inputs. HDMI and DVI only for HDMI inputs.</p> <p>Example: SEND_COMMAND VIDEO_INPUT_1, "'VIDIN_FORMAT-COMPONENT'"</p> <p>Sets the format of video input port (#1 based on D:P:S) to COMPONENT.</p>
?VIDIN_HDCP	<p>Queries the video input HDCP compliance setting of the video input port addressed by the D:P:S.</p> <p>Syntax: SEND_COMMAND <DEV>, "'?VIDIN_HDCP'"</p> <p>Example: SEND_COMMAND VIDEO_INPUT_1, "'?VIDIN_HDCP'"</p> <p>Returns a string of the form: VIDIN_STATUS-<ENABLE DISABLE>.</p>

Video SEND_COMMANDs (Cont.)	
VIDIN_HDCP	<p>Sets the video input HDCP compliance setting of the video input port addressed by the D:P:S. When VIDIN_HDCP is disabled, the addressed video input will appear to any source as not being HDCP compliant. For computer sources that encrypt all video when connected to an HDCP 1.4-compliant display, disabling HDCP compliance on the input will cause the computer to send non-encrypted video which can then be routed to non-compliant displays and video conferencing systems. This command is not available for DXLink input ports.</p> <p>NOTE: <i>It may be necessary to disconnect and re-connect PC sources after changing this setting.</i></p> <p>CAUTION: <i>Disabling HDCP compliance for sources that do not support non-compliant displays (such as DVD and Blu-Ray players) is not recommended and may affect DVX performance.</i></p> <p>Syntax: SEND_COMMAND <DEV>, " 'VIDIN_HDCP-<option>' "</p> <p>Variables: option = ENABLE, DISABLE (default = ENABLE)</p> <p>Example: SEND_COMMAND VIDEO_INPUT_1, " 'VIDIN_HDCP-ENABLE' "</p> <p>Enables the HDCP compliance of video input port (#1 based on D:P:S).</p>
?VIDIN_HDMI_EQ	<p>Requests the status of the equalizer on the HDMI port.</p> <p>Syntax: SEND_COMMAND <DEV>, " '?VIDIN_HDMI_EQ' "</p> <p>Example: SEND_COMMAND VIDEO_INPUT_1, " '?VIDIN_HDMI_EQ' "</p> <p>Returns a COMMAND string of the form: VIDIN_HDMI_EQ-DISABLE.</p>
VIDIN_HDMI_EQ	<p>Enables/disables the equalizer on the HDMI port addressed by D:P:S.</p> <p>Syntax: SEND_COMMAND <DEV>, " 'VIDIN_HDMI_EQ-<ENABLE DISBALE>' "</p> <p>Example: SEND_COMMAND " 'VIDIN_HDMI_EQ-DISABLE' "</p> <p>Disables the equalizer on the HDMI port.</p>
?VIDIN_HSHIFT	<p>Requests the input Horizontal shift of the VGA video port addressed by the D:P:S.</p> <p>Syntax: SEND_COMMAND <DEV>, " '?VIDIN_HSHIFT' "</p> <p>Example: SEND_COMMAND VIDEO_INPUT_1, " '?VIDIN_HSHIFT' "</p> <p>Returns a COMMAND string of the form: VIDIN_HSHIFT-<value>.</p>
VIDIN_HSHIFT	<p>Sets the horizontal shift of the video port addressed by the D:P:S to <value>.</p> <p>Syntax: SEND_COMMAND <DEV>, " 'VIDIN_HSHIFT-<value>' "</p> <p>Variables: value = -50..50</p> <p>Example: SEND_COMMAND " 'VIDIN_HSHIFT-2' "</p> <p>Sets the Horizontal shifting of VGA video input port (#1 based on D:P:S) to 2 (shift to right). SEND_COMMAND " 'VIDIN_HSHIFT--3' "</p> <p>Sets the horizontal shifting of VGA video input port (#1 based on D:P:S) to -3 (shift to left).</p>
?VIDIN_HUE	<p>Requests the input hue of the video port addressed by the D:P:S.</p> <p>Syntax: SEND_COMMAND <DEV>, " '?VIDIN_HUE' "</p> <p>Example: SEND_COMMAND VIDEO_INPUT_1, " '?VIDIN_HUE' "</p> <p>Returns a COMMAND string of the form: VIDIN_HUE-<value>.</p>
VIDIN_HUE	<p>Sets the input hue of the video port addressed by the D:P:S to <value>.</p> <p>Syntax: SEND_COMMAND <DEV>, " 'VIDIN_HUE-<value>' "</p> <p>Variables: value = 0..100</p> <p>Example: SEND_COMMAND VIDEO_INPUT_1, " 'VIDIN_HUE-50' "</p> <p>Sets the hue of video input port (#1 based on D:P:S) to 50.</p>

Video SEND_COMMANDs (Cont.)	
?VIDIN_NAME	<p>Requests the input name of the video port addressed by the D:P:S.</p> <p>Syntax: SEND_COMMAND <DEV>, "'?VIDIN_NAME'"</p> <p>Example: SEND_COMMAND VIDEO_INPUT_1, "'?VIDIN_NAME'"</p> <p>Returns a COMMAND string of the form: VIDIN_NAME-<name>.</p>
VIDIN_NAME	<p>Sets the input name of the video port addressed by the D:P:S to <name>. The <name> length is limited to 63 characters (31 characters for ICSP). Specifying a longer name will result in truncation to the character length limit. Valid characters are:</p> <ul style="list-style-type: none"> a-z // lower case letters A-Z // upper case letters 0-9 // numeric #.-_+= // special characters hash, period, dash, underscore, equal, plus <space> // space characters at the beginning of a name are truncated <p>Syntax: SEND_COMMAND <DEV>, "'VIDIN_NAME-<name>'"</p> <p>Variables: name = A string name. e.g.: "PC 1"</p> <p>Example: SEND_COMMAND VIDEO_INPUT_1, "'VIDIN_NAME-MyPC'"</p> <p>Sets the name of video input port (#1 based on D:P:S) to MyPC. This is used for the On Screen Display feature.</p>
?VIDIN_PHASE	<p>Requests the input phase of the video port addressed by the D:P:S. This command is valid only for inputs whose format is set to VGA.</p> <p>Syntax: SEND_COMMAND <DEV>, "'?VIDIN_PHASE'"</p> <p>Example: SEND_COMMAND VIDEO_INPUT_1, "'?VIDIN_PHASE'"</p> <p>Returns a COMMAND string of the form: VIDIN_PHASE-<value>.</p>
VIDIN_PHASE	<p>Sets the input phase of the video port addressed by the D:P:S to <value>. This command is valid only for inputs whose format is set to VGA.</p> <p>Syntax: SEND_COMMAND <DEV>, "'VIDIN_PHASE-<value>'"</p> <p>Variables: value = 0..32</p> <p>Example: SEND_COMMAND VIDEO_INPUT_1, "'VIDIN_PHASE-23'"</p> <p>Sets the phase of video input port (#1 based on D:P:S) to 23.</p>
?VIDIN_PREF_EDID	<p>Requests the preferred resolution of the EDID source being mirrored by the video port addressed by the D:P:S.</p> <p>Syntax: SEND_COMMAND <DEV>, "'?VIDIN_PREF_EDID'"</p> <p>Example: SEND_COMMAND VIDEO_INPUT_1, "'?VIDIN_PREF_EDID'"</p> <p>Returns a COMMAND string of the form: VIDIN_PREF_EDID-<resolution>.</p>
VIDIN_PREF_EDID	<p>Sets the preferred resolution for the EDID source to mirror in video input port addressed by D:P:S. You can only set the preferred resolution if you use the VIDIN_EDID command to set the EDID source to All Resolutions, Wide-screen, or Full-screen.</p> <p>Syntax: SEND_COMMAND <DEV>, "'VIDIN_PREF_EDID-<resolution>'"</p> <p>Example: SEND_COMMAND VIDEO_INPUT_1, "'VIDIN_PREF_EDID-1280x1024,60'"</p>
?VIDIN_RES_AUTO	<p>Requests to see if the video input port addressed by the D:P:S has its auto resolution setting enabled or disabled.</p> <p>Syntax: SEND_COMMAND <DEV>, "'?VIDIN_RES_AUTO'"</p> <p>Example: SEND_COMMAND VIDEO_INPUT_1, "'?VIDIN_RES_AUTO'"</p> <p>Returns a COMMAND string of the form: VIDIN_RES_AUTO-<ENABLE DISABLE>.</p>

Video SEND_COMMANDs (Cont.)	
VIDIN_RES_AUTO	<p>Enables or disables whether the video input port addressed by D:P:S is supposed to have its resolution auto detected.</p> <p>Syntax: SEND_COMMAND <DEV>, "'VIDIN_RES_AUTO-<ENABLE DISABLE>'"</p> <p>Example: SEND_COMMAND VIDEO_INPUT_1, "'VIDIN_RES_AUTO-ENABLE'"</p>
?VIDIN_RES_REF	<p>Requests to resolution of the video input port addressed by the D:P:S.</p> <p>Syntax: SEND_COMMAND <DEV>, "'?VIDIN_RES_REF'"</p> <p>Example: SEND_COMMAND VIDEO_INPUT_1, "'?VIDIN_RES_REF'"</p> <p>Returns a COMMAND string of the form: VIDIN_RES_REF-<h>x<v>,<rate>.</p>
VIDIN_RES_REF	<p>Sets the resolution and refresh rate of the video input port addressed by D:P:S. Invalid combinations are ignored by the SWITCHER.</p> <p>Syntax: SEND_COMMAND <DEV>, "'VIDIN_RES_REF-<horizontal>x<vertical>,<refresh-rate>'"</p> <p>Variables: horizontal = An integer value representing the horizontal. vertical = An integer value representing the vertical. May have an additional qualifier such as 'i' or 'p'. refresh-rate = An integer value representing the refresh rate.</p> <p>Example: SEND_COMMAND VIDEO_INPUT_1, "'VIDIN_RES_REF-1440x480i,59'"</p> <p>For a list of supported resolutions, see the <i>Appendix A - Input Resolutions</i> on page 113.</p>
?VIDIN_SATURATION	<p>Requests the input saturation of the video port addressed by the D:P:S.</p> <p>Syntax: SEND_COMMAND <DEV>, "'?VIDIN_SATURATION'"</p> <p>Example: SEND_COMMAND VIDEO_INPUT_1, "'?VIDIN_SATURATION'"</p> <p>Returns a COMMAND string of the form: VIDIN_SATURATION-<value>.</p>
VIDIN_SATURATION	<p>Sets the input saturation of the video port addressed by the D:P:S to <value>.</p> <p>Syntax: SEND_COMMAND <DEV>, "'VIDIN_SATURATION-<value>'"</p> <p>Variables: value = 0..100</p> <p>Example: SEND_COMMAND VIDEO_INPUT_1, "'VIDIN_SATURATION-50'"</p> <p>Sets the saturation of video input port (#1 based on D:P:S) to 50.</p>
?VIDIN_STATUS	<p>Requests the video input status of the video input port addressed by the D:P:S</p> <p>Syntax: SEND_COMMAND <DEV>, "'?VIDIN_STATUS'"</p> <p>Example: SEND_COMMAND VIDEO_INPUT_1, "'?VIDIN_STATUS'"</p> <p>Returns a COMMAND string of the form: VIDIN_STATUS-<status string> status string = NO SIGNAL, UNKNOWN SIGNAL, or VALID SIGNAL.</p>
?VIDIN_VSHIFT	<p>Requests the input Vertical shifting of the RGB video port addressed by the D:P:S.</p> <p>Syntax: SEND_COMMAND <DEV>, "'?VIDIN_VSHIFT'"</p> <p>Example: SEND_COMMAND VIDEO_INPUT_1, "'?VIDIN_VSHIFT'"</p> <p>Returns a COMMAND string of the form: VIDIN_VSHIFT-<value>.</p>
VIDIN_VSHIFT	<p>Sets the vertical shift of the video port addressed by the D:P:S to <value>.</p> <p>Syntax: SEND_COMMAND <DEV>, "'VIDIN_VSHIFT-<value>'"</p> <p>Variables: value = -10..10</p> <p>Example: SEND_COMMAND "'VIDIN_VSHIFT-2'"</p> <p>Sets the vertical shifting of RGB video input port (#1 based on D:P:S) to 2 (shift upward). SEND_COMMAND "'VIDIN_VSHIFT--3'"</p> <p>Sets the vertical shifting of RGB video input port (#1 based on D:P:S) to -3 (shift downward).</p>

Video SEND_COMMANDs (Cont.)	
?VIDOUT_ASPECT_RATIO	<p>Requests the aspect ratio of the video output port addressed by the D:P:S.</p> <p>Syntax: SEND_COMMAND <DEV>, "'?VIDOUT_ASPECT_RATIO'"</p> <p>Example: SEND_COMMAND VIDEO_OUTPUT_1, "'?VIDOUT_ASPECT_RATIO'"</p> <p>Returns a COMMAND string of the form: VIDOUT_ASPECT_RATIO-<ratio>. See the VIDOUT_ASPECT_RATIO command for the list of aspect ratios.</p>
VIDOUT_ASPECT_RATIO	<p>Sets the aspect ratio of the video output port addressed by the D:P:S. Note that the <ratio> value is case sensitive.</p> <p>Syntax: SEND_COMMAND <DEV>, "'VIDOUT_ASPECT_RATIO-<ratio>'"</p> <p>Variables: ratio = MAINTAIN, STRETCH, ZOOM, ANAMORPHIC</p> <p>NOTE: This command also accepts FULL in place of MAINTAIN.</p> <p>Example: SEND_COMMAND VIDEO_OUTPUT_1, "'VIDOUT_ASPECT_RATIO-ZOOM'"</p>
?VIDOUT_BLANK	<p>Requests the image setting of the video blanking feature on the video port addressed by the D:P:S.</p> <p>Syntax: SEND_COMMAND <DEV>, "'?VIDOUT_BLANK'"</p> <p>Example: SEND_COMMAND VIDEO_OUTPUT_1, "'?VIDOUT_BLANK'"</p> <p>Returns a COMMAND string of the form: VIDOUT_BLANK-<image>. See the VIDOUT_BLANK command for the list of images.</p>
VIDOUT_BLANK	<p>Sets the image of the video blanking feature for the video output port addressed by the D:P:S.</p> <p>Syntax: SEND_COMMAND <DEV>, "'VIDOUT_BLANK-<color>'"</p> <p>Variables: image = black, blue, logo 1, logo 2, logo 3</p> <p>Example: SEND_COMMAND VIDEO_OUTPUT_1, "'VIDOUT_BLANK-logo 1'"</p>
?VIDOUT_BRIGHTNESS	<p>Requests the output brightness of the video port addressed by the D:P:S.</p> <p>Syntax: SEND_COMMAND <DEV>, "'?VIDOUT_BRIGHTNESS'"</p> <p>Example: SEND_COMMAND VIDEO_OUTPUT_1, "'?VIDOUT_BRIGHTNESS'"</p> <p>Returns a COMMAND string of the form: VIDOUT_BRIGHTNESS-<value>.</p>
VIDOUT_BRIGHTNESS	<p>Sets the output brightness of the video port addressed by the D:P:S to <value>.</p> <p>Syntax: SEND_COMMAND <DEV>, "'VIDOUT_BRIGHTNESS-<value>'"</p> <p>Variables: value = 0..100</p> <p>Example: SEND_COMMAND VIDEO_OUTPUT_1, "'VIDOUT_BRIGHTNESS-50'"</p> <p>Sets the brightness of video output port (#1 based on D:P:S) to 50.</p>
?VIDOUT_CONTRAST	<p>Requests the output contrast of the video port addressed by the D:P:S.</p> <p>Syntax: SEND_COMMAND <DEV>, "'?VIDOUT_CONTRAST'"</p> <p>Example: SEND_COMMAND VIDEO_OUTPUT_1, "'?VIDOUT_CONTRAST'"</p> <p>Returns a COMMAND string of the form: VIDOUT_CONTRAST-<value>.</p>
VIDOUT_CONTRAST	<p>Sets the output contrast of the video port addressed by the D:P:S to <value>.</p> <p>Syntax: SEND_COMMAND <DEV>, "'VIDOUT_CONTRAST-<value>'"</p> <p>Variables: value = 0..100</p> <p>Example: SEND_COMMAND VIDEO_OUTPUT_1, "'VIDOUT_CONTRAST-50'"</p> <p>Sets the contrast of video output port (#1 based on D:P:S) to 50.</p>

Video SEND_COMMANDs (Cont.)	
?VIDOUT_FREEZE	Requests the status of the freeze option of the video port addressed by the D:P:S. Syntax: SEND_COMMAND <DEV>, "'?VIDOUT_FREEZE'" Example: SEND_COMMAND VIDEO_OUTPUT_1, "'?VIDOUT_FREEZE'" Returns a COMMAND string of the form: VIDOUT_FREEZE-<ENABLE DISABLE>.
VIDOUT_FREEZE	Enables or disables the Freeze setting on the video port addressed by the D:P:S. If enabled, then the Freeze setting is on. If disabled, then the Freeze setting is off. Syntax: SEND_COMMAND <DEV>, "' VIDOUT_FREEZE-<ENABLE DISABLE>'" Example: SEND_COMMAND VIDEO_OUTPUT_1, "' VIDOUT_FREEZE-ENABLE'"
?VIDOUT_HSHIFT	Requests the horizontal shifting of the video output port addressed by the D:P:S. Syntax: SEND_COMMAND <DEV>, "'?VIDOUT_HSHIFT'" Example: SEND_COMMAND VIDEO_OUTPUT_1, "'?VIDOUT_HSHIFT'" Returns a COMMAND string of the form: VIDOUT_HSHIFT-<value>.
VIDOUT_HSHIFT	Sets the horizontal shift of the video output port addressed by the D:P:S to <value>. Syntax: SEND_COMMAND <DEV>, "'VIDOUT_HSHIFT-<value>'" Variables: value = -127..127 Example: SEND_COMMAND "'VIDOUT_HSHIFT-2'" Sets the horizontal shifting of video output port (#1 based on D:P:S) to 2 (shift to right). SEND_COMMAND "'VIDOUT_VSHIFT--3'" Sets the horizontal shifting of video output port (#1 based on D:P:S) to -3 (shift to left).
?VIDOUT_HSIZE	Requests the horizontal size of the video port addressed by the D:P:S. Syntax: SEND_COMMAND <DEV>, "'?VIDOUT_HSIZE'" Example: SEND_COMMAND VIDEO_OUTPUT_1, "'?VIDOUT_HSIZE'" Returns a COMMAND string of the form: VIDOUT_HSIZE-<value>.
VIDOUT_HSIZE	Sets the horizontal size of the image on the video port addressed by the D:P:S to <value>. Syntax: SEND_COMMAND <DEV>, "'VIDOUT_HSIZE-<value>'" Variables: value = 25..800 Example: SEND_COMMAND VIDEO_OUTPUT_1, "'VIDOUT_HSIZE-100'" Sets the horizontal size of video output port (#1 based on D:P:S) to 100.
?VIDOUT_MUTE	Requests to see if VIDEO mute is enabled or disabled. Syntax: SEND_COMMAND <DEV>, "'?VIDOUT_MUTE'" Example: SEND_COMMAND SWITCHER, "'?VIDOUT_MUTE'" Returns a COMMAND string of the form: VIDOUT_MUTE<ENABLE DISABLE>
VIDOUT_MUTE	Enables or disables the video output display. Syntax: SEND_COMMAND <DEV>, "'VIDOUT_MUTE-<ENABLE DISABLE>'" Example: SEND_COMMAND SWITCHER, "'VIDOUT_MUTE-ENABLE'"
?VIDOUT_ON	Requests to see if a video output is enabled or disabled. Syntax: SEND_COMMAND <DEV>, "'?VIDOUT_ON'" Example: SEND_COMMAND SWITCHER, "'?VIDOUT_ON'" Returns a COMMAND string of the form: VIDOUT_ON-<ON OFF>.
VIDOUT_ON	Turns on or turns off a video display. Syntax: SEND_COMMAND <DEV>, "'VIDOUT_ON-<ON OFF>'" Example: SEND_COMMAND SWITCHER, "'VIDOUT_ON-ON'"

Video SEND_COMMANDS (Cont.)																
?VIDOUT_OSD	Requests whether the video port addressed by the D:P:S has the OSD setting enabled or disabled. Syntax: SEND_COMMAND <DEV>, "'?VIDOUT_OSD'" Example: SEND_COMMAND VIDEO_OUTPUT_1, "'?VIDOUT_OSD'" Returns a COMMAND string of the form: VIDOUT_OSD-<ENABLE DISABLE>.															
VIDOUT_OSD	Enables or Disables the On Screen Display (OSD) setting on the video port addressed by the D:P:S. If enabled, then the OSD setting is on. If disabled, then the OSD setting is off. Syntax: SEND_COMMAND <DEV>, "VIDOUT_'OSD-<ENABLE DISABLE>'" Example: SEND_COMMAND VIDEO_OUTPUT_1, "VIDOUT_OSD-ENABLE'"															
?VIDOUT_OSD_COLOR	Requests the On Screen Display (OSD) color on the display connected to the video port addressed by the D:P:S. Syntax: SEND_COMMAND <DEV>, "'?VIDOUT_OSD_COLOR'" Example: SEND_COMMAND VIDEO_OUTPUT_1, "'?VIDOUT_OSD_COLOR'" Returns a COMMAND string of the form: VIDOUT_OSD_COLOR-<color>.															
VIDOUT_OSD_COLOR	Determines the On Screen Display (OSD) color scheme on the display connected to the video port addressed by the D:P:S. Variables: color = black, blue, white, yellow Schemes: <table border="1"> <thead> <tr> <th>Options</th> <th>Background</th> <th>Font</th> </tr> </thead> <tbody> <tr> <td>Black</td> <td>Black</td> <td>White</td> </tr> <tr> <td>Blue</td> <td>Blue</td> <td>Yellow</td> </tr> <tr> <td>White</td> <td>White</td> <td>Black</td> </tr> <tr> <td>Yellow</td> <td>Yellow</td> <td>Blue</td> </tr> </tbody> </table> Syntax: SEND_COMMAND <DEV>, "VIDOUT_OSD_COLOR-<color>'" Example: SEND_COMMAND VIDEO_OUTPUT_1, "VIDOUT_OSD_COLOR-BLACK'"	Options	Background	Font	Black	Black	White	Blue	Blue	Yellow	White	White	Black	Yellow	Yellow	Blue
Options	Background	Font														
Black	Black	White														
Blue	Blue	Yellow														
White	White	Black														
Yellow	Yellow	Blue														
?VIDOUT_OSD_POS	Requests the On Screen Display (OSD) position on the display connected to the video port addressed by the D:P:S. Syntax: SEND_COMMAND <DEV>, "'?VIDOUT_OSD_POS'" Example: SEND_COMMAND VIDEO_OUTPUT_1, "'?VIDOUT_OSD_POS'" Returns a COMMAND string of the form: VIDOUT_OSD_POS-<position>.															
VIDOUT_OSD_POS	Determines the On Screen Display (OSD) position on the display connected to the video port addressed by the D:P:S. Variables: position = TOP LEFT, TOP RIGHT, BTM RIGHT, BTM LEFT Syntax: SEND_COMMAND <DEV>, "VIDOUT_OSD_POS-<position>'" Example: SEND_COMMAND VIDEO_OUTPUT_1, "VIDOUT_OSD_POS-TOP LEFT"															
?VIDOUT_RES	Requests to resolution of the video output port addressed by the D:P:S. Syntax: SEND_COMMAND <DEV>, "'?VIDOUT_RES'" Example: SEND_COMMAND VIDEO_OUTPUT_1, "'?VIDOUT_RES'" Returns a COMMAND string of the form: VIDOUT_RES-<h>x<v>,<rate>.															
?VIDOUT_RES_AUTO	See the <i>VIDOUT_SCALE</i> section on page 109.															
VIDOUT_RES_AUTO	See the <i>VIDOUT_SCALE</i> section on page 109.															
?VIDOUT_RES_REF	Requests the resolution and refresh rate of the video output port addressed by the D:P:S. Syntax: SEND_COMMAND <DEV>, "'?VIDOUT_RES_REF'" Example: SEND_COMMAND VIDEO_OUTPUT_1, "'?VIDOUT_RES_REF'" Returns a COMMAND string of the form: VIDOUT_RES_REF-<h>x<v>,<rate>.															

Video SEND_COMMANDS (Cont.)	
VIDOUT_RES_REF	<p>Sets the resolution and refresh rate of the video output port addressed by D:P:S. Invalid combinations are ignored by the All-In-One Presentation Switcher.</p> <p>Syntax: SEND_COMMAND <DEV>, " 'VIDOUT_RES_REF-<horizontal>x<vertical>,<refresh-rate>' "</p> <p>Variables: horizontal = An integer value representing the horizontal. vertical = An integer value representing the vertical. May have an additional qualifier such as 'i' or 'p'. refresh-rate = An integer value representing the refresh rate.</p> <p>Example: SEND_COMMAND VIDEO_OUTPUT_1, " 'VIDOUT_RES_REF-1280x1024,60' "</p> <p>For a list of supported resolutions, see the <i>Appendix B - Output Resolutions</i> on page 116.</p>
?VIDOUT_SCALE	<p>Requests to see which scaling mode the video output port addressed by the D:P:S is using.</p> <p>Syntax: SEND_COMMAND <DEV>, " '?VIDOUT_SCALE' "</p> <p>Example: SEND_COMMAND VIDEO_OUTPUT_1, " '?VIDOUT_SCALE' "</p> <p>Returns a COMMAND string of the form: VIDOUT_SCALE-<scale>.</p>
VIDOUT_SCALE	<p>Sets the scaling mode for the video output port addressed by D:P:S.</p> <p>Syntax: SEND_COMMAND <DEV>, " 'VIDOUT_SCALE-<scale>' "</p> <p>Variables: scale = Auto, Manual, or Bypass</p> <p>Example: SEND_COMMAND VIDEO_OUTPUT_1, " 'VIDOUT_SCALE-AUTO' "</p>
?VIDOUT_TESTPAT	<p>Requests the test pattern setting for the video output port.</p> <p>Syntax: SEND_COMMAND <DEV>, " '?VIDOUT_TESTPAT' "</p> <p>Example: SEND_COMMAND VIDEO_OUTPUT_1, " '?VIDOUT_TESTPAT' "</p> <p>Returns a COMMAND string of the form: VIDOUT_TESTPAT-<pattern>. See the <i>VIDOUT_TESTPAT</i> command for the list of test patterns.</p>
VIDOUT_TESTPAT	<p>Sets the test pattern to display for the video output port.</p> <p>Syntax: SEND_COMMAND <DEV>, " 'VIDOUT_TESTPAT-<pattern>' "</p> <p>Variables: pattern = Off, Color Bar, Gray Ramp, SMPTE Bar, HiLoTrak, Pluge, X-Hatch, Logo 1, Logo 2, Logo 3 (These options are *not* case sensitive.)</p> <p>Example: SEND_COMMAND VIDEO_OUTPUT_1, " 'VIDOUT_TESTPAT-X-Hatch' "</p> <p>Sets the test pattern to display to 'X-Hatch'.</p>
?VIDOUT_VSHIFT	<p>Requests the vertical shifting of the video output port addressed by the D:P:S.</p> <p>Syntax: SEND_COMMAND <DEV>, " '?VIDOUT_VSHIFT' "</p> <p>Example: SEND_COMMAND VIDEO_OUTPUT_1, " '?VIDOUT_VSHIFT' "</p> <p>Returns a COMMAND string of the form: VIDOUT_VSHIFT-<value>.</p>
VIDOUT_VSHIFT	<p>Sets the vertical shift of the video output port addressed by the D:P:S to <value>.</p> <p>Syntax: SEND_COMMAND <DEV>, " 'VIDOUT_VSHIFT-<value>' "</p> <p>Variables: value = -127..127</p> <p>Example: SEND_COMMAND " 'VIDOUT_VSHIFT-2' "</p> <p>Sets the vertical shifting of video output port (#1 based on D:P:S) to 2 (shift upward). SEND_COMMAND " 'VIDOUT_VSHIFT--3' "</p> <p>Sets the vertical shifting of video output port (#1 based on D:P:S) to -3 (shift downward).</p>
?VIDOUT_VSIZE	<p>Requests the vertical size value of the image displayed on the video output port addressed by the D:P:S.</p> <p>Syntax: SEND_COMMAND <DEV>, " '?VIDOUT_VSIZE' "</p> <p>Example: SEND_COMMAND VIDEO_OUTPUT_1, " '?VIDOUT_VSIZE' "</p> <p>Returns a COMMAND string of the form: VIDOUT_VSIZE-<value>.</p>

Video SEND_COMMANDs (Cont.)	
VIDOUT_VSIZE	<p>Sets the vertical size of the image displayed on the video output port addressed by the D:P:S to <value>.</p> <p>Syntax: SEND_COMMAND <DEV>, "'VIDOUT_VSIZE-<value>'"</p> <p>Variables: value = 25..800</p> <p>Example: SEND_COMMAND VIDEO_OUTPUT_1, "'VIDOUT_VSIZE-100'"</p> <p>Sets the vertical size of video output port (#1 based on D:P:S) to 100.</p>
?VIDOUT_ZOOM	<p>Requests the zoom of the video port for the video output port addressed by the D:P:S.</p> <p>Syntax: SEND_COMMAND <DEV>, "'?VIDOUT_ZOOM'"</p> <p>Example: SEND_COMMAND VIDEO_OUTPUT_1, "'?VIDOUT_ZOOM'"</p> <p>Returns a COMMAND string of the form: VIDOUT_ZOOM-<value>.</p>
VIDOUT_ZOOM	<p>Sets the zoom of the image on the video output port addressed by the D:P:S to <value>.</p> <p>NOTE: <i>Adjusting the video output zoom also adjusts the horizontal and vertical sizes of the video output.</i></p> <p>Syntax: SEND_COMMAND <DEV>, "'VIDOUT_ZOOM-<value>'"</p> <p>Variables: value = 25..800</p> <p>Example: SEND_COMMAND VIDEO_OUTPUT_1, "'VIDOUT_ZOOM-100'"</p> <p>Sets the zoom of video output port (#1 based on D:P:S) to 100.</p>

Front Panel SEND_COMMANDS

The following table lists the front panel SEND_COMMANDS available for the DVX:

Front Panel SEND_COMMANDS	
?FP_LOCKOUT	Requests to see if the Front Panel is locked out. Syntax: SEND_COMMAND <DEV>, "'?FP_LOCKOUT'" Example: SEND_COMMAND SWITCHER, "'?FP_LOCKOUT'" Returns a COMMAND string of the form: FP_LOCKOUT-<ENABLE DISABLE>.
FP_LOCKOUT	Enables or Disables whether the Front Panel is supposed to be locked out. Syntax: SEND_COMMAND <DEV>, "'FP_LOCKOUT-<ENABLE DISABLE>'" Example: SEND_COMMAND SWITCHER, "'FP_LOCKOUT-ENABLE'"
?FP_LOCKTYPE	Requests the type of lockout set for the front panel. Syntax: SEND_COMMAND <DEV>, "'?FP_LOCKTYPE'" Example: SEND_COMMAND SWITCHER, "'?FP_LOCKTYPE'" Returns a COMMAND string of the form: FP_LOCKTYPE-<Value>. Value = 1: lock out all menus; 2: reserved; 3: lockout configure menu only
FP_LOCKTYPE	Sets the lockout type for front panel. Syntax: SEND_COMMAND <DEV>, "'FP_LOCKTYPE-<value>'" Variable: value = 1: lock out all menus; 2: reserved; 3: lockout configure menu only Example: SEND_COMMAND SWITCHER, "FP_LOCKTYPE-1"
?INTENSITY_LCD	Requests the intensity setting of the LCD screen on the Front Panel. Syntax: SEND_COMMAND <DEV>, "'?INTENSITY_LCD'" Example: SEND_COMMAND SWITCHER, "'?INTENSITY_LCD'" Returns a COMMAND string of the form: INTENSITY_LCD-<value>.
INTENSITY_LCD	Sets the intensity of the lighting/brightness of the LCD screen that is part of the Front Panel. Syntax: SEND_COMMAND <DEV>, "'INTENSITY_LCD-<intensity-value>'" Variable: intensity-value = An integer value in the range of 0-100 with 0 being no illumination and 100 being maximum illumination. Example: SEND_COMMAND SWITCHER, "'INTENSITY_LCD-50'" Sets the intensity of the LCD screen on the Front Panel to 50.
?INTENSITY_LEDS	Requests the intensity setting of the LED buttons on the Front Panel. Syntax: SEND_COMMAND <DEV>, "'?INTENSITY_LEDS'" Example: SEND_COMMAND SWITCHER, "'?INTENSITY_LEDS'" Returns a COMMAND string of the form: INTENSITY_LEDS-<value>.
INTENSITY_LEDS	Sets the intensity of the lighting/brightness of the LED buttons on the Front Panel. Syntax: SEND_COMMAND <DEV>, "'INTENSITY_LEDS-<intensity-value>'" Variable: intensity-value = An integer value in the range of 0-100 with 0 being no illumination and 100 being maximum illumination. Example: SEND_COMMAND SWITCHER, "'INTENSITY_LEDS-50'" Sets the intensity of the LED buttons on the Front Panel to 50.

System SEND_COMMANDS

The following table lists the System SEND_COMMANDS available for the DVX:

System SEND_COMMANDS	
?DXLINK_ETH	<p>Requests the control setting for the DXLINK output card.</p> <p>Syntax: SEND_COMMAND <DEV>, "'?DXLINK_ETH'"</p> <p>Example: SEND_COMMAND SWITCHER, "'?DXLINK_ETH'"</p> <p>Returns a COMMAND string of the form: DXLINK_ETH-<auto off>.</p>
DXLINK_ETH	<p>This command instructs the output DXLINK card to disable Ethernet traffic or go to auto mode. In Auto mode, Ethernet traffic is controlled after negotiation through PDIF.</p> <p>Syntax: SEND_COMMAND <DEV>, "'DXLINK_ETH-<auto off>'"</p> <p>Example: SEND_COMMAND SWITCHER, "'DXLINK_ETH-auto'"</p>
?DXLINK_IN_ETH	<p>Requests the control setting for the DXLINK input card.</p> <p>Syntax: SEND_COMMAND <DEV>, "'?DXLINK_IN_ETH'"</p> <p>Example: SEND_COMMAND SWITCHER, "'?DXLINK_IN_ETH'"</p> <p>Returns a COMMAND string of the form: DXLINK_IN_ETH-<auto off>.</p>
DXLINK_IN_ETH	<p>This command instructs the input DXLINK card to disable Ethernet traffic or go to auto mode. In Auto mode, Ethernet traffic is controlled after negotiation through PDIF.</p> <p>Syntax: SEND_COMMAND <DEV>, "'DXLINK_IN_ETH-<auto off>'"</p> <p>Example: SEND_COMMAND SWITCHER, "'DXLINK_IN_ETH-auto'"</p>
?FAN_SPEED	<p>Requests the speed of the fans inside the unit.</p> <p>Syntax: SEND_COMMAND <DEV>, "'?FAN_SPEED-<fan>'"</p> <p>Variable: fan = The specific fan you want to check. Can be 1 or 2.</p> <p>Example: SEND_COMMAND SWITCHER, "'?FAN_SPEED-1'"</p> <p>Returns a COMMAND string of the form: FAN_SPEED-<fan1><fan2>.</p>
?TEMP	<p>Requests the temperature detected inside the controller.</p> <p>Syntax: SEND_COMMAND <DEV>, "'?TEMP'"</p> <p>Example: SEND_COMMAND dvDev, "'?TEMP'"</p> <p>Returns a COMMAND string of the form: TEMP-<temp value in C>.</p>

Appendix A - Input Resolutions

Available Pixel Display and Refresh Rates

The available pixel display and refresh rates for the input devices on the DVX are listed in the following sections.

DVI, HDMI, and VGA Supported Input Resolutions

DVI, HDMI, and VGA Supported Input Resolutions							
Resolution Name	Horizontal Active Pixels	Vertical Active Lines	Refresh (Hz)	HDMI & DVI Support	VGA Support	Comments	Video Standard
640x400@85	640	400	85	✓	✓		VESA DMT
640x480@60	640	480	60	✓	✓		VESA DMT
640x480@72	640	480	72	✓	✓		VESA DMT
640x480@75	640	480	75	✓	✓		VESA DMT
640x480@85	640	480	85	✓	✓		VESA DMT
720x400@85	720	400	85	✓	✓		VESA DMT
720x480p@60	720	480	60	✓	✓	480p	CEA 861
720x480p@120	720	480	120	✓	✓	480p	CEA 861
720x480p@240	720	480	240	✓	✓	480p	CEA 861
720x576p@50	720	576	50	✓	✓	576p	CEA 861
720x576p@100	720	576	100	✓	✓	576p	CEA 861
720x576p@200	720	576	200	✓	✓	576p	CEA 861
800x500@60	800	500	60	✓	✓		VESA CVT
800x600@56	800	600	56	✓	✓		VESA DMT
800x600@60	800	600	60	✓	✓		VESA DMT
800x600@72	800	600	72	✓	✓		VESA DMT
800x600@75	800	600	75	✓	✓		VESA DMT
800x600@85	800	600	85	✓	✓		VESA DMT
848x480@60	848	480	60	✓	✓		VESA DMT
848x480@75	848	480	75	✓	✓		VESA CVT
848x480@85	848	480	85	✓	✓		VESA CVT
1024x640@60	1024	640	60	✓	✓		VESA CVT
1024x768@60	1024	768	60	✓	✓		VESA DMT
1024x768@70	1024	768	70	✓	✓		VESA DMT
1024x768@75	1024	768	75	✓	✓		VESA DMT
1024x768@85	1024	768	85	✓	✓		VESA DMT
1152x864@75	1152	864	75	✓	✓		VESA DMT
1280x720@50	1280	720	50	✓	✓		CEA 861
1280x720@60	1280	720	60	✓	✓		VESA CVT
1280x720p@60	1280	720	60	✓	✓	720p	CEA 861
1280x720p@100	1280	720	100	✓	✓	720p	CEA 861
1280x720p@120	1280	720	120	✓	✓	720p	CEA 861
1280x768@59	1280	768	59	✓	✓		VESA CVT
1280x768@60	1280	768	60	✓	✓		VESA DMT
1280x768@74	1280	768	74	✓	✓		VESA DMT
1280x768@75	1280	768	75	✓	✓		VESA DMT
1280x768@84	1280	768	84	✓	✓		VESA DMT
1280x768@85	1280	768	85	✓	✓		VESA DMT
1280x800@60	1280	800	60	✓	✓		VESA CVT
1280x960@60	1280	960	60	✓	✓		VESA DMT

DVI, HDMI, and VGA Supported Input Resolutions (Cont.)							
Resolution Name	Horizontal Active Pixels	Vertical Active Lines	Refresh (Hz)	HDMI & DVI Support	VGA Support	Comments	Video Standard
1280x960@85	1280	960	85	✓	✓		VESA DMT
1280x1024@60	1280	1024	60	✓	✓		VESA DMT
1280x1024@75	1280	1024	75	✓	✓		VESA DMT
1280x1024@85	1280	1024	85	✓	✓		VESA DMT
1360x764@60	1360	764	60	✓	✓		VESA CVT
1360x768@60	1360	768	60	✓	✓		VESA DMT
1400x1050@60	1400	1050	60	✓	✓		VESA DMT
1400x1050@75	1400	1050	75	✓	✓		VESA DMT
1440x900@60	1440	900	60	✓	✓		VESA DMT
1440x900@75	1440	900	75	✓	✓		VESA DMT
1440x900@85	1440	900	85	✓	✓		VESA DMT
1600x1200@60	1600	1200	60	✓	✓		VESA DMT
1680x1050@60	1680	1050	60	✓	✓		VESA CVT
1920x1080i@50	1920	540	50	✓		HDMI & DVI only - 1080i	CEA 861
1920x1080i@60	1920	540	60	✓		HDMI & DVI only - 1080i	CEA 861
1920x1080p@25	1920	1080	25	✓	✓	1080p	CEA 861
1920x1080p@30	1920	1080	30	✓	✓	1080p	CEA 861
1920x1080p@50	1920	1080	50	✓	✓	1080p	CEA 861
1920x1080@60	1920	1080	60		✓	VGA only	VESA CVT
1920x1080p@60	1920	1080	60	✓	✓	1080p	CEA 861
1920x1200@60	1920	1200	60	✓	✓	Reduced Blanking	VESA CVT

Composite and S-Video Supported Input Resolutions

Composite and S-Video Supported Input Resolutions					
Resolution Name	Horizontal Active Pixels	Vertical Active Pixels	Refresh (Hz)	Comments	Video Standard
720x480i@60	720	240	60	480i	CEA
720x576i@50	720	288	50	576i	CEA

Component Video Supported Input Resolutions

Component Video Supported Input Resolutions					
Resolution Name	Horizontal Active Pixels	Vertical Active Pixels	Refresh (Hz)	Comments	Video Standard
720x480i@60	720	240	59.9	480i	CEA 770.2
720x480p@60	720	480	59.9	480p	SMPTE 293M CEA 770.2 ITU-R BT.1358
720x576i@50	720	288	50	576i	
720x576p@50	720	576	50	576p	ITU-R BT.1358
1280x720p@50	1280	720	50	720p50	SMPTE 296M
1280x720p@60	1280	720	59.9	720p	SMPTE 296M CEA 770.3
1920x1080i@50	1920	540	50	1080i50	SMPTE 274M
1920x1080i@60	1920	540	59.9	1080i	SMPTE 274M CEA 770.3
1920x1080p@50	1920	1080	50	1080p50	SMPTE 274M
1920x1080p@60	1920	1080	59.9	1080p	SMPTE 274M

Appendix B - Output Resolutions

Available Pixel Display and Refresh Rates

The available pixel display and refresh rates for the output devices on the DVX are listed in the following section.

DVI and HDMI Supported Output Resolutions

DVI and HDMI Supported Output Resolutions					
Resolution Name	Horizontal Active Pixels	Vertical Active Pixels	Refresh (Hz)	Comments	Video Standard
640x480@60	640	480	60		VESA DMT
640x480@72	640	480	72		VESA DMT
640x480@75	640	480	75		VESA DMT
800x600@60	800	600	60		VESA DMT
800x600@72	800	600	72		VESA DMT
800x600@75	800	600	75		VESA DMT
1024x768@60	1024	768	60		VESA DMT
1024x768@70	1024	768	70		VESA DMT
1024x768@75	1024	768	75		VESA DMT
1280x720p@60	1280	720	60	720p	CEA 861
1280x768@60	1280	768	60		
1280x800@60	1280	800	60		VESA CVT
1280x1024@60	1280	1024	60		VESA DMT
1360x768@60	1360	768	60		VESA DMT
1440x900@60	1440	900	60		VESA CVT
1600x1200@60	1600	1200	60		VESA DMT
1680x1050@60	1680	1050	60		VESA CVT
1920x1080@60	1920	1080	60	1080	VESA CVT
1920x1080p@60	1920	1080	60	1080p	CEA 861
1920x1200@60	1920	1200	60	Reduced Blanking	VESA CVT-R

Appendix C - Volume Attenuation Table

Overview

Volume attenuation on the DVX is not set by percentage, like it was on earlier DVX models: On the DVX, the output volume slider changes .5dB per click, to provide a more subtle adjustment.

Unity gain is at 88, so a setting of 100 is actually 6dB gain. A setting of 20 would be -34 reduction (88-20=68 clicks. @ .5dB per click =34 dB). This is only the output slider.

Volume Attenuation			
Percent	Decibels	Percent	Decibels
100	6.0	49	-19.5
99	5.5	48	-20.0
98	5.0	47	-20.5
97	4.5	46	-21.0
96	4.0	45	-21.5
95	3.5	44	-22.0
94	3.0	43	-22.5
93	2.5	42	-23.0
92	2.0	41	-23.5
91	1.5	40	-24.0
90	1.0	39	-24.5
89	0.5	38	-25.0
88	0.0	37	-25.5
87	-0.5	36	-26.0
86	-1.0	35	-26.5
85	-1.5	34	-27.0
84	-2.0	33	-27.5
83	-2.5	32	-28.0
82	-3.0	32	-28.5
81	-3.5	30	-29.0
80	-4.0	29	-29.5
79	-4.5	28	-30.0
78	-5.0	27	-30.5
77	-5.5	26	-32.0
76	-6.0	25	-32.5
75	-6.5	24	-32.0
74	-7.0	23	-32.5
73	-7.5	22	-33.0
72	-8.0	21	-33.5
71	-8.5	20	-34.0
70	-9.0	19	-34.5
69	-9.5	18	-35.0
68	-10.0	17	-35.5
67	-10.5	16	-36.0
66	-11.0	15	-36.5
65	-11.5	14	-37.0
64	-12.0	13	-37.5
63	-12.5	12	-38.0
62	-13.0	11	-38.5
61	-13.5	10	-39.0
60	-14.0	9	-41.0

Volume Attenuation (Cont.)			
Percent	Decibels	Percent	Decibels
59	-14.5	8	-46.0
58	-15.0	7	-51.0
57	-15.5	6	-56.0
56	-16.0	5	-61.0
55	-16.5	4	-66.0
54	-17.0	3	-71.0
53	-17.5	2	-76.0
52	-18.0	1	-81.0
51	-18.5	0	Infinity
50	-19.0		



© 2017 Harman. All rights reserved. NetLinx, Enova, WebControl, SmartScale, AMX, AV FOR AN IT WORLD, and HARMAN, and their respective logos are registered trademarks of HARMAN. Oracle, Java and any other company or brand name referenced may be trademarks/registered trademarks of their respective companies.

AMX does not assume responsibility for errors or omissions. AMX also reserves the right to alter specifications without prior notice at any time.

The AMX Warranty and Return Policy and related documents can be viewed/downloaded at www.amx.com.

3000 RESEARCH DRIVE, RICHARDSON, TX 75082 AMX.com | 800.222.0193 | 469.624.8000 | +1.469.624.7400 | fax 469.624.7153

AMX (UK) LTD, AMX by HARMAN - Unit C, Auster Road, Clifton Moor, York, YO30 4GD United Kingdom • +44 1904-343-100 • www.amx.com/eu/



Last Revised:
01/31/2017