

Studer Vista 5 Black Edition

Digital Mixing System, SW V5.3

0. Safety/Conformity Information
1. Introduction, Operating Features
2. Desk Operation
3. Parameter Description
4. Graphical Controller (GC) Operation
5. AutoTouch + Dynamic Automation
6. Session Configuration Tool for Infinity Core
7. DAW Control
8. RELINK - Resource Linking
9. Vista FX

Disclaimer

The information in this document has been carefully checked and is believed to be accurate at the time of publication. However, no responsibility is taken by us for inaccuracies, errors, or omissions, nor is any liability assumed for any loss or damage resulting either directly or indirectly from use of the information contained within it.

Prepared and edited by
Studer Professional Audio GmbH
Technical Documentation
Riedthofstrasse 214
CH-8105 Regensdorf - Switzerland

Copyright by Harman Professional

Order no. 5036304

<http://www.studer.ch>

Subject to change

Studer is a registered trade mark of Studer Professional Audio GmbH, Regensdorf

For Your Own Safety and to Avoid Invalidation of the Warranty Please Read This Section Carefully

- Read these instructions.
- Keep these instructions.
- Heed all warnings.
- Follow all instructions.
- Do not use this apparatus near water.
- Clean only with a dry cloth.
- Do not block any ventilation openings. Install in accordance with the manufacturer's instructions.
- Do not install near any heat sources such as radiators, heat registers, stoves, or other apparatus (including amplifiers) that produce heat.
- Do not defeat the safety purpose of a polarised or grounding type plug. A polarised plug has two blades with one wider than the other. A grounding type plug has two blades and a third grounding prong. The wide blade or the third prong are provided for your safety. If the provided plug does not fit into your outlet, consult an electrician for replacement of the obsolete outlet
- Protect the power cord from being walked on or pinched particularly at plugs, convenience receptacles and the point where they exit from the apparatus.
- Only use attachments/accessories specified by the manufacturer.
- Use only with the cart, stand, tripod, bracket or table specified by the manufacturer, or sold with the apparatus. When a cart is used, use caution when moving the cart/apparatus combination to avoid injury from tip-over.
- Refer all servicing to qualified service personnel. Servicing is required when the apparatus has been damaged in any way, such as the power supply cord or plug is damaged, liquid has been spilled or objects fallen into the apparatus, the apparatus has been exposed to rain or moisture, does not operate normally, or has been dropped.

Note: It is recommended that all maintenance and service on the product should be carried out by Studer or its authorised agents. Studer cannot accept any liability whatsoever for any loss or damage caused by service, maintenance or repair by unauthorised personnel.

WARNING: To reduce the risk of fire or electric shock, do not expose this apparatus to rain or moisture. Do not expose the apparatus to dripping or splashing and do not place objects filled with liquids, such as vases, on the apparatus.

- No naked flame sources, such as lighted candles, should be placed on the apparatus.
- Ventilation should not be impeded by covering the ventilation openings with items such as newspapers, table cloths, curtains etc.

WARNING: Do not use this apparatus in very dusty atmospheres, or in atmospheres containing flammable gases or chemicals.

- **THIS APPARATUS MUST BE EARTHED.** Under no circumstances should the safety earth be disconnected from the mains lead.
- The mains supply disconnect device is the mains plug. It must remain accessible so as to be readily operable when the apparatus is in use.
- If any part of the mains cord set is damaged, the complete cord set should be replaced. The following information is for reference only. The wires in the mains lead are coloured in accordance with the following code:

- **Protective Earth (Ground): Green/Yellow (US: Green or Green/Yellow)**
- **Neutral: Blue (US: White)**
- **Live (Hot): Brown (US: Black)**

As the colours of the wires in the mains lead may not correspond with the coloured markings identifying the terminals in your plug, proceed as follows:

- The wire which is coloured Green and Yellow must be connected to the terminal in the plug which is marked with the letter E or by the earth symbol.
- The wire which is coloured Blue must be connected to the terminal in the plug which is marked with the letter N.
- The wire which is coloured Brown must be connected to the terminal in the plug which is marked with the letter L.

Ensure that these colour codes are followed carefully in the event of the plug being changed

- This unit is capable of operating over a range of mains voltages, as marked on the rear panel.

Lithium Battery



Installed lithium batteries must be replaced by the same or an equivalent type. Danger of explosion if batteries are incorrectly replaced or when terminals are shorted.

Installed lithium batteries must not be exposed to excessive heat such as direct sunshine, fire or the like.

Note:

This equipment has been tested and found to comply with the limits for a Class A digital device, pursuant to Part 15 of the FCC Rules. These limits are designed to provide reasonable protection against harmful interference when the equipment is operated in a commercial environment. This equipment generates, uses and can radiate radio frequency energy and, if not installed and used in accordance with the instruction manual, may cause harmful interference to radio communications. Operation of this equipment in a residential area is likely to cause harmful interference in which case the user will be required to correct the interference at his own expense.

This Class A digital apparatus meets the requirements of the Canadian Interference-Causing Equipment Regulations.

Cet appareil numérique de la Classe A respecte toutes les exigences du Règlement sur le matériel brouilleur du Canada.

Working Safely With Sound

Although your new console will not make any noise until you feed it signals, it has the capability to produce sounds that, when monitored through a monitor system or headphones, can damage hearing over time. The table below is taken from the Occupational Safety & Health Administration directive on occupational noise exposure (1926.52):

Permissible Noise Exposure:



| Duration per day [h] | Sound level [dBA, slow response] |
|----------------------|----------------------------------|
| 8 | 90 |
| 6 | 92 |
| 4 | 95 |
| 3 | 97 |
| 2 | 100 |
| 1.5 | 102 |
| 1 | 105 |
| 0.5 | 110 |
| <0.25 | 115 |

Conforming to this directive will minimise the risk of hearing damage caused by long listening periods. A simple rule to follow is: The longer you listen, the lower the average volume should be. Please take care when working with your audio system – if you are manipulating controls which you don't understand (which we all do when we are learning), make sure your monitoring level is turned down. *Remember that your ears are the most important tool of your trade. Look after them, and they will look after you. Most importantly: Don't be afraid to experiment to find out how each parameter affects the sound; this will extend your creativity and help you to get the best results.*

A1 Safety Symbol Guide

For your own safety and to avoid invalidation of the warranty, all text marked with these symbols should be read carefully.



To reduce the risk of electric shock, do not remove covers. No user-serviceable parts inside. Refer servicing to qualified service personnel (i.e., persons having appropriate technical training and experience necessary to be aware of hazards to which they are exposed in performing a repair action, and of measures to minimize the danger of themselves).



The lightning flash with arrowhead symbol is intended to alert the user to the presence of un-insulated “dangerous voltage” within the product’s enclosure that may be of sufficient magnitude to constitute a risk of electric shock to persons.



The exclamation point within an equilateral triangle is intended to alert the user to the presence of important operating and maintenance (servicing) instructions in the literature accompanying the appliance.



Headphones safety warnings contain important information and useful tips on headphone outputs and monitoring levels.



Assemblies or sub-assemblies of this product can contain opto-electronic devices. As long as these devices comply with Class I of laser or LED products according to EN 60825-1:1994, they will not be expressly marked on the product. If a special design should be covered by a higher class of this standard, the device concerned will be marked directly on the assembly or sub-assembly in accordance with the above standard.



A2 First Aid

In Case of Electric Shock:

Separate the person as quickly as possible from the electric power source:

- By switching the equipment off,
- By unplugging or disconnecting the mains cable, or
- By pushing the person away from the power source, using dry insulating material (such as wood or plastic).
- After having suffered an electric shock, always consult a doctor.

Warning!



Do not touch the person or his clothing before the power is turned off, otherwise you stand the risk of suffering an electric shock as well!

If the Person is Unconscious:

- Lay the person down
- Turn him to one side
- Check the pulse
- Reanimate the person if respiration is poor
- Call for a doctor immediately.

B General Installation Instructions

Please consider besides these general instructions also any product-specific instructions in the “Installation” chapter of this manual.

B1 Unpacking

Check the equipment for any transport damage. If the unit is mechanically damaged, if liquids have been spilled or if objects have fallen into the unit, it must not be connected to the AC power outlet, or it must be immediately disconnected by unplugging the power cable. Repair must only be performed by trained personnel in accordance with the applicable regulations.

B2 Installation Site

Install the unit in a place where the following conditions are met:

- The temperature and the relative humidity of the environment must be within the specified limits during operation of the unit. Relevant values are the ones at the air inlets of the unit (refer to Appendix 1).
- Condensation must be avoided. If the unit is installed in a location with large variation of ambient temperature (e.g. in an OB-van), appropriate precautions must be taken before and after operation (refer to Appendix 1).
- Unobstructed air flow is essential for proper operation. Air vents of the unit are a functional part of the design and must not be blocked in any way during operation (e.g. by objects placed upon them, placement of the unit on a soft surface, or installation of the unit within a rack or piece of furniture).
- The unit must not be heated up by external sources of heat radiation (sunlight, spotlights).

B3 Earthing and Power Supply

Earthing of units with mains supply (class I equipment) is performed via the protective earth (PE) conductor integrated in the mains cable. Units with battery operation (< 60 V, class III equipment) must be earthed separately. Earthing the unit is one of the measures for protection against electrical shock hazard (dangerous body currents). Hazardous voltage may not only be caused by a defective power supply insulation, but may also be introduced by the connected audio or control cables.

If the unit is installed with one or several external connections, its earthing must be provided during operation as well as while the unit is not operated. If the earthing connection can be interrupted, for example, by unplugging the mains plug of an external power supply unit, an additional, permanent earthing connection must be installed using the provided earth terminal.

Avoid ground loops (hum loops) by keeping the loop surface as small as possible (by consequently guiding the earth conductors in a narrow, parallel way), and reduce the noise current flowing through the loop by inserting an additional impedance (common-mode choke).

Class I Equipment (Mains Operation)

Should the equipment be delivered without a matching mains cable, the latter has to be prepared by a trained person using the attached female plug (IEC 320 / C13 or IEC 320 / C19) with respect to the applicable regulations in your country.

Before connecting the equipment to the AC power outlet, check that the local line voltage matches the equipment rating (voltage, frequency) within the admissible tolerance. The equipment fuses must be rated in accordance with the specifications on the equipment.

Equipment supplied with a 3-pole appliance inlet (protection conforming to class I equipment) must be connected to a 3-pole AC power outlet in such a way that the equipment cabinet is connected to the protective earth.

For information on mains cable strain relief, please refer to Appendix 2.

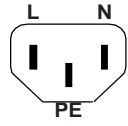
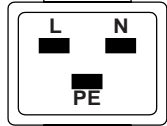
| Female Plugs (IEC320), Front-Side View: | | | | | |
|--|-----------------------|-------------------------------|--|--|--|
|  IEC 320 / C13 | | |  IEC 320 / C19 | | |
| European Standard (CENELEC) | | North American Standard (NAS) | | | |
| Brown | L (Live) | Black | | | |
| Blue | N (Neutral) | White | | | |
| Green/Yellow | PE (Protective Earth) | Green (or Green/Yellow) | | | |

Class III Equipment (Battery Operation up to 60 VDC)

Equipment of this protection class must be earthed using the provided earth terminal if one or more external signals are connected to the unit (see explanation at the beginning of this paragraph).

B4 Electromagnetic Compatibility (EMC)

The unit conforms to the protection requirements relevant to electromagnetic phenomena that are listed in guidelines 89/336/EC and FCC, part 15.

- The electromagnetic interference generated by the unit is limited in such a way that other equipment and systems can be operated normally.
- The unit is adequately protected against electromagnetic interference so that it can operate properly.

The unit has been tested and conforms to the EMC standards of the specified electromagnetic environment, as listed in the following declaration. The limits of these standards ensure protection of the environment and corresponding noise immunity of the equipment with appropriate probability. However, a professional installation and integration within the system are imperative prerequisites for operation without EMC problems.

For this purpose, the following measures must be followed:

- Install the equipment in accordance with the operating instructions. Use the supplied accessories.
- In the system and in the vicinity where the equipment is installed, use only components (systems, equipment) that also fulfill the EMC standards for the given environment.

- Use a system grounding concept that satisfies the safety requirements (class I equipment must be connected with a protective ground conductor) and that also takes into consideration the EMC requirements. When deciding between radial, surface, or combined grounding, the advantages and disadvantages should be carefully evaluated in each case.
- Use shielded cables where shielding is specified. The connection of the shield to the corresponding connector terminal or housing should have a large surface and be corrosion-proof. Please note that a cable shield connected only single-ended can act as a transmitting or receiving antenna within the corresponding frequency range.
- Avoid ground loops or reduce their adverse effects by keeping the loop surface as small as possible, and reduce the noise current flowing through the loop by inserting an additional impedance (e.g. common-mode choke).
- Reduce electrostatic discharge (ESD) of persons by installing an appropriate floor covering (e.g. a carpet with permanent electrostatic filaments) and by keeping the relative humidity above 30%. Further measures (e.g. conducting floor) are usually unnecessary and only effective if used together with corresponding personal equipment.
- When using equipment with touch-sensitive operator controls, please take care that the surrounding building structure allows for sufficient capacitive coupling of the operator. This coupling can be improved by an additional, conducting surface in the operator's area, connected to the equipment housing (e.g. metal foil underneath the floor covering, carpet with conductive backing).

C Maintenance

All air vents and openings for operating elements (faders, rotary knobs) must be checked on a regular basis, and cleaned in case of dust accumulation. For cleaning, a soft paint-brush or a vacuum cleaner is recommended.

Cleaning the surfaces of the unit is performed with a soft, dry cloth or a soft brush.

Persistent contamination can be treated with a cloth that is slightly humidified with a mild cleaning solution, such as dishwashing detergent.

For cleaning display windows, commercially available computer/TV screen cleaners are suited. Use only a slightly damp (never wet) cloth.

Never use any solvents for cleaning the exterior of the unit! Liquids must never be sprayed or poured on directly!

For equipment-specific maintenance information please refer to the corresponding chapter in the operating and service manuals.

D Electrostatic Discharge during Maintenance and Repair

Caution:



Observe the precautions for handling devices sensitive to electrostatic discharge!

Many semiconductor components are sensitive to electrostatic discharge (ESD). The lifespan of assemblies containing such components can be drastically reduced by improper handling during maintenance and repair. Please observe the following rules when handling ESD sensitive components:

- ESD sensitive components should only be stored and transported in the packing material specifically provided for this purpose.

- When performing a repair by replacing complete assemblies, the removed assembly must be sent back to the supplier in the same packing material in which the replacement assembly was shipped. If this should not be the case, any claim for a possible refund will be null and void.
- Unpacked ESD sensitive components should only be handled in ESD protected areas (EPA, e.g. area for field service, repair or service bench) and only be touched by persons wearing a wristlet connected to the ground potential of the repair or service bench by a series resistor. The equipment to be repaired or serviced as well as all tools and electrically semi-conducting work, storage, and floor mats should also be connected to this ground potential.
- The terminals of ESD sensitive components must not come in uncontrolled contact with electrostatically chargeable or metallic surfaces (voltage puncture, discharge shock hazard).
- To prevent the components from undefined transient stress and possible damage due to inadmissible voltages or compensation currents, electrical connections should only be established or separated when the equipment is switched off and after any capacitor charges have decayed.

E Repair

By removing housing parts or shields, energized parts may be exposed. For this reason the following precautions must be observed:

- Maintenance may only be performed by trained personnel in accordance with the applicable regulations.
- The equipment must be switched off and disconnected from the AC power outlet before any housing parts are removed.
- Even if the equipment is disconnected from the power outlet, parts with hazardous charges (e.g. capacitors, picture tubes) must not be touched until they have been properly discharged. Do not touch hot components (power semiconductors, heat sinks, etc.) before they have cooled off.
- If maintenance is performed on a unit that is opened while being switched on, no un-insulated circuit components and metallic semiconductor housings must be touched, neither with bare hands nor with un-insulated tools.

Certain components pose additional hazards:

- Explosion hazard from lithium batteries, electrolytic capacitors and power semiconductors (Observe the component's polarity. Do not short battery terminals. Replace batteries only by the same type).
- Implosion hazard from evacuated display units.
- Radiation hazard from laser units (non-ionizing), picture tubes (ionizing).
- Caustic effect of display units (LCD) and components containing liquid electrolyte.

Such components should only be handled by trained personnel who are properly protected (e.g. protection glasses, gloves).

F Disposal

- Packing Materials** The packing materials have been selected with environmental and disposal issues in mind. All packing material can be recycled. Recycling packing saves raw materials and reduces the volume of waste.
If you need to dispose of the transport packing materials, please try to use recyclable means.
- Used Equipment** Used equipment contains valuable raw materials as well as materials that must be disposed of professionally. Please return your used equipment via an authorized specialist dealer or via the public waste disposal system, ensuring any material that can be recycled is.
Please take care that your used equipment cannot be abused. To avoid abuse, delete sensitive data from any data storage media. After having disconnected your used equipment from the mains supply, make sure that the mains connector and the mains cable are made useless.

G Declarations of Conformity

G1 Class A Equipment - FCC Notice

This equipment has been tested and found to comply with the limits for a Class A digital device, pursuant to Part 15 of the FCC Rules. These limits are designed to provide a reasonable protection against harmful interference when the equipment is operated in a commercial environment. This equipment generates, uses, and can radiate radio frequency energy and, if not installed and used in accordance with the instruction manual, may cause harmful interference to radio communications. Operation of this equipment in a residential area is likely to cause harmful interference, in which case the user will be required to correct the interference at his own expense.

Caution: *Any changes or modifications not expressly approved by the manufacturer could void the user's authority to operate the equipment. Also refer to relevant information in this manual*

G2 CE Declaration of Conformity

We,

**Studer Professional Audio GmbH,
CH-8105 Regensdorf,**

declare under our sole responsibility that the product

Studer Vista 5, Vista 5 SR, Vista 5 M2, Vista 5 M3 and Vista 5 Black Edition Digital Mixing Systems (from serial no. 1000),

to which this declaration relates, according to following regulations of EU directives and amendments

- Low Voltage (LVD):
73/23/EEC + 93/68/EEC
- Electromagnetic Compatibility (EMC):
89/336/EEC + 92/31/EEC + 93/68/EEC

are in conformity with the following standards or normative documents:

- Safety:
EN 60950-1:2001 (Class I equipment)
- Safety of laser products:
EN 60825-1:2004 + A11 + A2, EN60825-2:2000
- EMC:
EN 55103-1/-2:1996, electromagnetic environments E2 and E4.

Regensdorf, August 30, 2007



B. Hochstrasser, President



M. Lienert, Manager R&D

Appendix 1: Air Temperature and Humidity

General

Normal operation of the unit or system is warranted under the ambient conditions defined by *EN 60721-3-3, set IE32, value 3K3*.

This standard consists of an extensive catalogue of parameters, the most important of which are: ambient temperature +5...+40 °C, relative humidity 5...85% (i.e., no formation of condensation or ice); absolute humidity 1...25 g/m³; rate of temperature change < 0.5 °C/min. These parameters are dealt with in the following paragraphs.

Under these conditions the unit or system starts and works without any problem. Beyond these specifications, possible problems are described below.

Ambient Temperature

Units and systems by Studer are generally designed for an ambient temperature range (i.e. temperature of the incoming air) of +5 °C to +40 °C. When rack mounting the units, the intended air flow and herewith adequate cooling must be provided. The following facts must be considered:

- The admissible ambient temperature range for operation of the semiconductor components is 0 °C to +70 °C (commercial temperature range for operation).
- The air flow through the installation must provide that the outgoing air is always cooler than 70 °C.
- Average heat increase of the cooling air shall be about 20 K, allowing for an additional maximum 10 K increase at the hot components.
- In order to dissipate 1 kW with this admissible average heat increase, an air flow of 2.65 m³/min is required.

Example: A rack dissipating $P = 800 \text{ W}$ requires an air flow of $0.8 * 2.65 \text{ m}^3/\text{min}$ which corresponds to $2.12 \text{ m}^3/\text{min}$.

- If the cooling function of the installation must be monitored (e.g. for fan failure or illumination with spot lamps), the outgoing air temperature must be measured directly above the modules at several places within the rack. The trigger temperature of the sensors should be 65 °C to 70 °C.

Frost and Dew

The unsealed system parts (connector areas and semiconductor pins) allow for a minute formation of ice or frost. However, formation of dew visible to the naked eye will already lead to malfunctions. In practice, reliable operation can be expected in a temperature range above -15 °C, if the following general rule is considered for putting the cold system into operation:

If the air within the system is cooled down, the relative humidity rises. If it reaches 100%, condensation will arise, usually in the boundary layer between the air and a cooler surface, together with formation of ice or dew at sensitive areas of the system (contacts, IC pins, etc.). Once internal condensation occurs, trouble-free operation cannot be guaranteed, independent of temperature.

Before putting into operation, the system must be checked for internal formation of condensation or ice. Only with a minute formation of ice, direct

evaporation (sublimation) may be expected; otherwise the system must be heated and dried while switched off.

A system without visible internal formation of ice or condensation should be heated up with its own heat dissipation, as homogeneously (and subsequently as slow) as possible; the ambient temperature should then always be lower than the one of the outgoing air.

If it is absolutely necessary to operate the cold system immediately within warm ambient air, this air must be dehydrated. In such a case, the absolute humidity must be so low that the relative humidity, related to the coldest system surface, always remains below 100%.

Ensure that the enclosed air is as dry as possible when powering off (i.e. before switching off in winter, aerate the room with cold, dry air, and remove humid objects such as clothes from the room).

These relationships are visible from the following climatogram. For a controlled procedure, thermometer and hygrometer as well as a thermometer within the system will be required.

- Example 1:** An OB-van having an internal temperature of +20 °C and a relative humidity of 40% is switched off in the evening. If the temperature falls below +5 °C, the relative humidity will rise to 100% (7 g/m³); dew or ice will be forming.
- Example 2:** An OB-van is heated up in the morning with air of +20 °C and a relative humidity of 40%. On all parts being cooler than +5 °C, dew or ice will be forming.

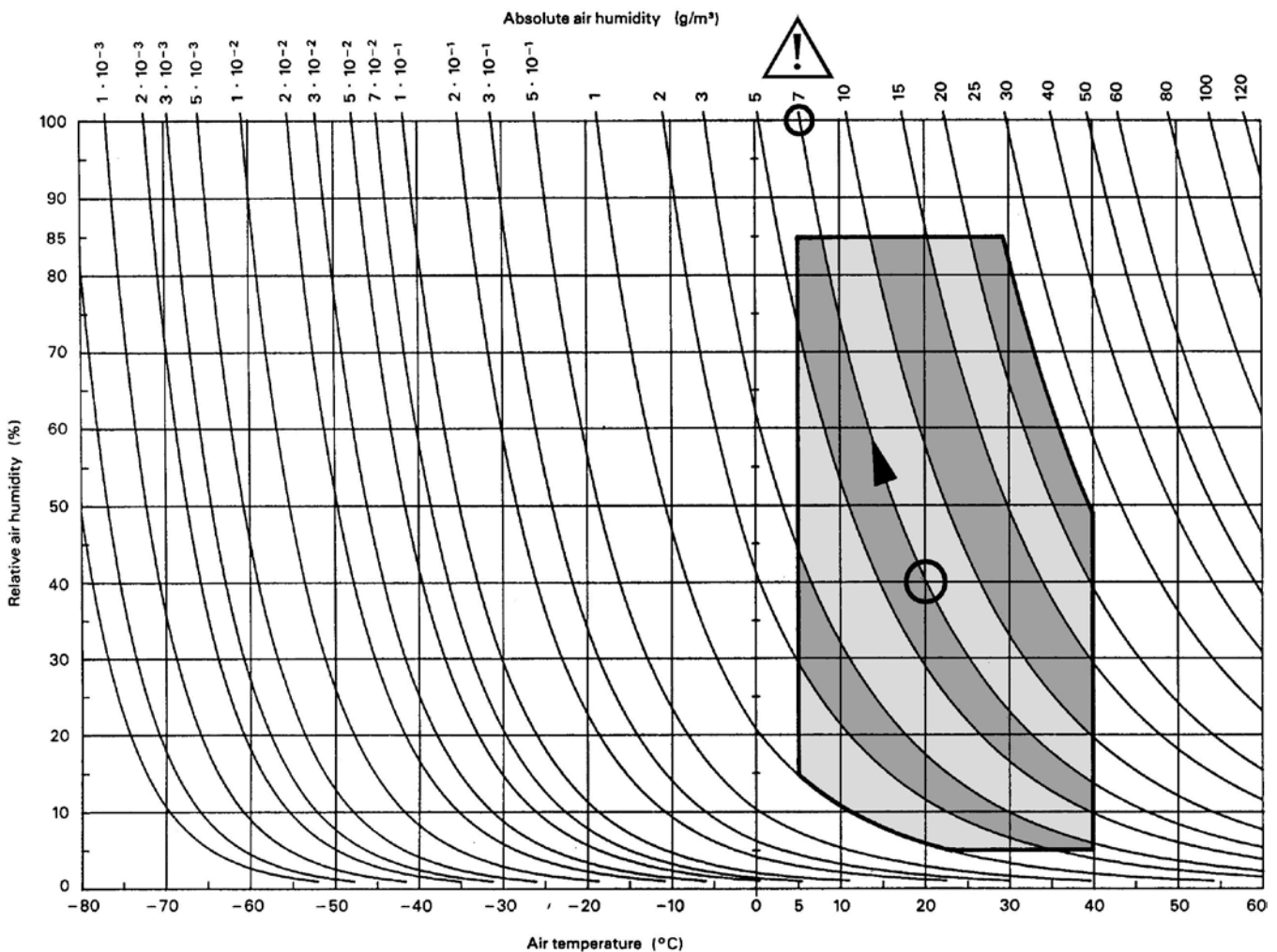

Appendix 2: Mains Connector Strain Relief

For anchoring connectors without a mechanical lock (e.g. IEC mains connectors), we recommend the following arrangement:

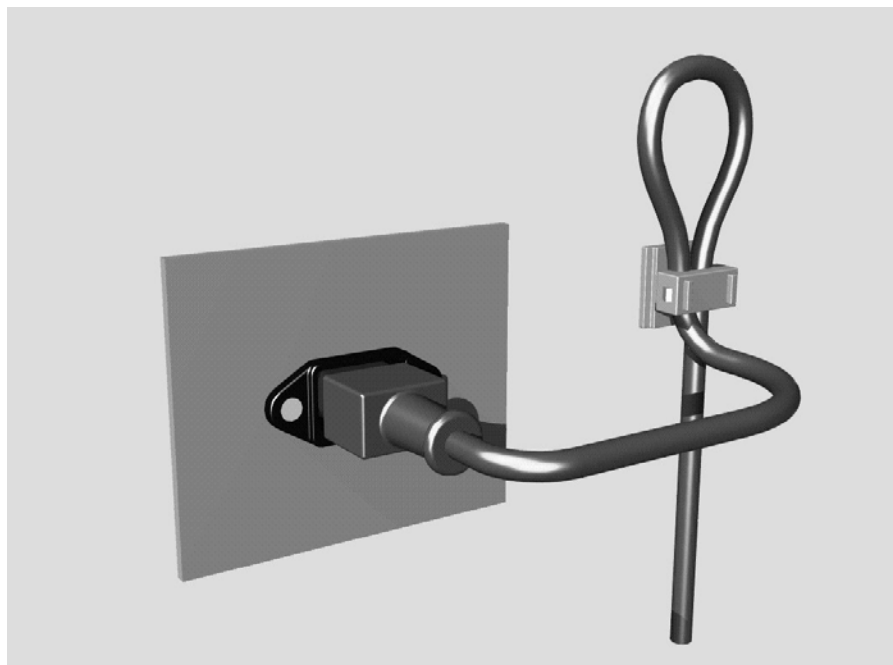

Procedure: The cable clamp shipped with your unit is auto-adhesive. For mounting please follow the rules below:

- The surface to be adhered to must be clean, dry, and free from grease, oil, or other contaminants. Recommended application temperature range is +20 °C to +40 °C.
- Remove the plastic protective backing from the rear side of the clamp and apply it firmly to the surface at the desired position. Allow as much time as possible for curing. The bond continues to develop for as long as 24 hours.
- For improved stability, the clamp should be fixed with a screw. For this purpose, a self-tapping screw and an M4 bolt and nut are included.
- Place the cable into the clamp as shown in the illustration above and firmly press down the internal top cover until the cable is fixed.

Appendix 3: Software License

Use of the software is subject to the Studer Professional Audio Software License Agreement set forth below. Using the software indicates your acceptance of this license agreement. If you do not accept these license terms, you are not authorized to use this software.

Under the condition and within the scope of the following Terms and Conditions, Studer Professional Audio GmbH (hereinafter ‘Studer’) grants the right to use programs developed by Studer as well as those of third parties which have been installed by Studer on or within its products. References to the license programs shall be references to the newest release of a license program installed at the Customer’s site.

Programs Covered by the Agreement

License Programs of Studer The following Terms and Conditions grant the right to use all programs of Studer that are part of the System and/or its options at the time of its delivery to the Customer, as well as the installation software on the original data disk and the accompanying documentation (‘License Material’). In this Agreement the word ‘Programs’ shall have the meaning of programs and data written in machine code.

Using the software indicates your acceptance of this license agreement. If you do not accept these license terms, you are not authorized to use this software.

Programs of Third Parties Programs of third parties are all programs which constitute part of the System and/or its options at the time of delivery to the Customer but have not been developed by Studer. The following conditions are applicable to programs of third parties:

- The right to use third parties’ programs is governed by the License Agreement attached hereto (if applicable), which is an integral part of this Agreement. The Customer shall sign any and all License Agreements for all further programs of third parties installed on the system. The Customer shall be deemed to have received all License Agreements upon delivery of the system and/or its options.
- Studer shall accept no responsibility or liability for, and gives no warranties (express or implied) as to the programs of third parties. The Customer waives any and all claims versus Studer for any consequential damages, which might occur due to defects of these programs.

Right of Use

Principle Studer grants the Customer the non-exclusive right to use the License Material in one copy on the system and/or its options as laid down by the Sales Agreement concluded between the parties and all Terms and Conditions which shall be deemed to form and be read and construed as part of the Sales Agreement. This right is assignable according to the ‘Assignability’ paragraph hereinafter.

Customized Configurations The Customer is not entitled to alter or develop further the License Material except within the expressly permitted configuration possibilities given by the software installed on the system or elsewhere. All altered programs, including but not limited to the products altered within the permitted configuration possibilities, are covered by this License Agreement.

| | |
|---------------------------------------|--|
| Reverse Engineering | Reverse engineering is only permitted with the express consent of Studer. The consent of Studer can be obtained but is not limited to the case in which the interface software can not be provided by Studer. In any case Studer has to be informed immediately upon complete or partial reverse engineering. |
| Copying the License Material | The Customer is entitled to make one copy of all or parts of the License Material as is necessary for the use according to this Agreement, namely for backup purposes. The Customer shall apply the copyright of Studer found on the License Material onto all copies made by him. Records shall be kept by the Customer regarding the amount of copies made and their place of keeping. The responsibility for the original program and all copies made lies with the Customer. Studer is entitled to check these records on first request. Copies not needed anymore have to be destroyed immediately. |
| Disclosure of License Material | <p>The License Material is a business secret of Studer. The Customer shall not hand out or in any way give access to parts of or the complete License Material to third parties nor to publish any part of the License Material without prior written consent of Studer. The Customer shall protect the License Material and any copies made according to the paragraph above by appropriate defense measures against unauthorized access. This obligation of non-disclosure is a perpetual obligation.</p> <p>Third parties are entitled to have access to the License Material if they use the License Material at the Customer's site in compliance with this Agreement. Under no circumstance are third parties entitled to have access to the installation software on the original data media. The Customer shall safeguard the original data media accordingly.</p> |
| Assignability | The rights granted to the Customer according to this License Agreement shall only be assignable to a third party together with the transfer of the system and/or its options and after the prior written consent of Studer |

Rights to License Material

With the exception of the right of use granted by this License Agreement all proprietary rights to the License Material, especially the ownership and the intellectual property rights (such as but not limited to patents and copyright) remain with Studer even if alterations, customized changes or amendments have been made to the License Material.

Studer's proprietary rights are acknowledged by the Customer. The Customer shall undertake no infringements and make no claims of any patent, registered design, copyright, trade mark or trade name, or other intellectual property right.

Warranty, Disclaimer, and Liability

For all issues not covered here within, refer to the 'General Terms and Conditions of Sales and Delivery' being part of the sales contract.

CHAPTER 1

| | | |
|----------|---|----------|
| 1 | Introduction..... | 2 |
| 1.1 | Operating Principles | 2 |
| 1.1.1 | Vistonics® | 3 |
| 1.1.2 | Momentary/Latching Key Activation ☺ | 6 |
| 1.1.3 | Ganging | 7 |
| 1.1.4 | Copy/Paste..... | 8 |
| 1.1.5 | Scrolling | 9 |
| 1.1.6 | FaderGlow™..... | 10 |
| 1.1.7 | TFT Level Meters (Option)..... | 11 |
| 1.2 | The Graphical Controller (GC)..... | 12 |
| 1.2.1 | GC Screen Examples..... | 13 |
| 1.3 | Channels, Routing, and Buses | 16 |
| 1.4 | Processing Blocks..... | 17 |
| 1.5 | Monitoring and Communication | 17 |
| 1.6 | Static Automation Functions | 19 |
| 1.7 | Input Channel Block Diagrams | 20 |

1 INTRODUCTION

1.1 Operating Principles



Studer Vista 5 BE incorporates operating principles that are applicable throughout nearly the whole console operation:

- Vistonics®
- Momentary/Latching Key Activation
- Ganging
- Scrolling
- FaderGlow®
- TFT Meterbridge (optional, see picture above)

These operating principles are described below. They are freely combinable. Some exceptions may occur where the combination of functions is not practical. The real speed and easiness of operation will become obvious to a sound engineer by using and combining these operating principles in every day life.

1.1.1 Vistonics®

Vistonics® allows color and shape of controls to be varied according to good ergonomic practice. A given audio function is always associated with the same color, and a parameter is always associated with the same icon displaying values graphically – just as or even more intuitive than an analog console. Vistonics® makes it possible to bring the location where you can see a value to exactly the place where you control it. Therefore, tiring translation processes between looking at a screen and finding the corresponding hardware control somewhere else are not existing anymore, saving just a little time and energy a few hundred times a day!

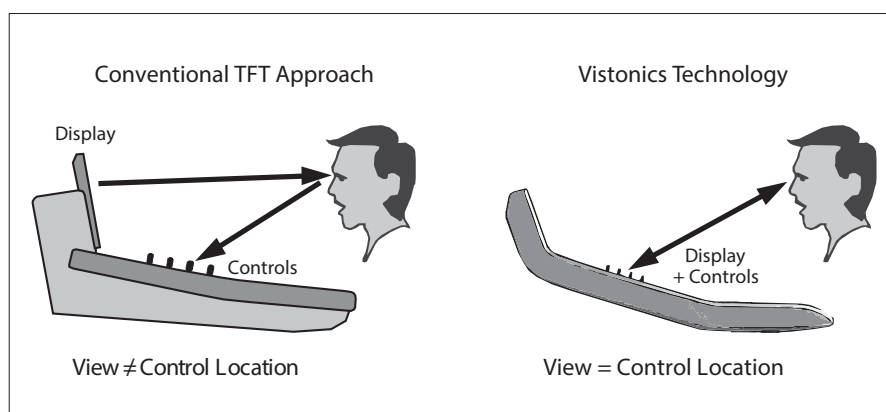

Great attention has been paid in order to make the current association clearly visible. Color coding has been used to indicate families of audio functions such as EQ, dynamics, etc. Consistent icons make the physical meaning of an audio function obvious – e.g. bar graph-like icons indicate levels, time adjustments are indicated by clock dials, etc. This way, it is easy to identify the currently associated function even from a distance.

The Vistonics® module consists of two main parts: 40 rotary controls with push buttons next to each of them, as well as a touch screen area, showing graphically the most important settings of each channel: Dynamics, EQ and panning information. It is possible to change the association of a rotary control to audio functions either globally or locally:

Global Views Up to our different parameters are shown in each channel strip. The same four parameters will be shown globally on the whole console. This mode is meant to be the 'horizontal way of operation', mostly used for e.g. operating auxiliaries or input settings. The picture below shows a global AUX 1...4 view.

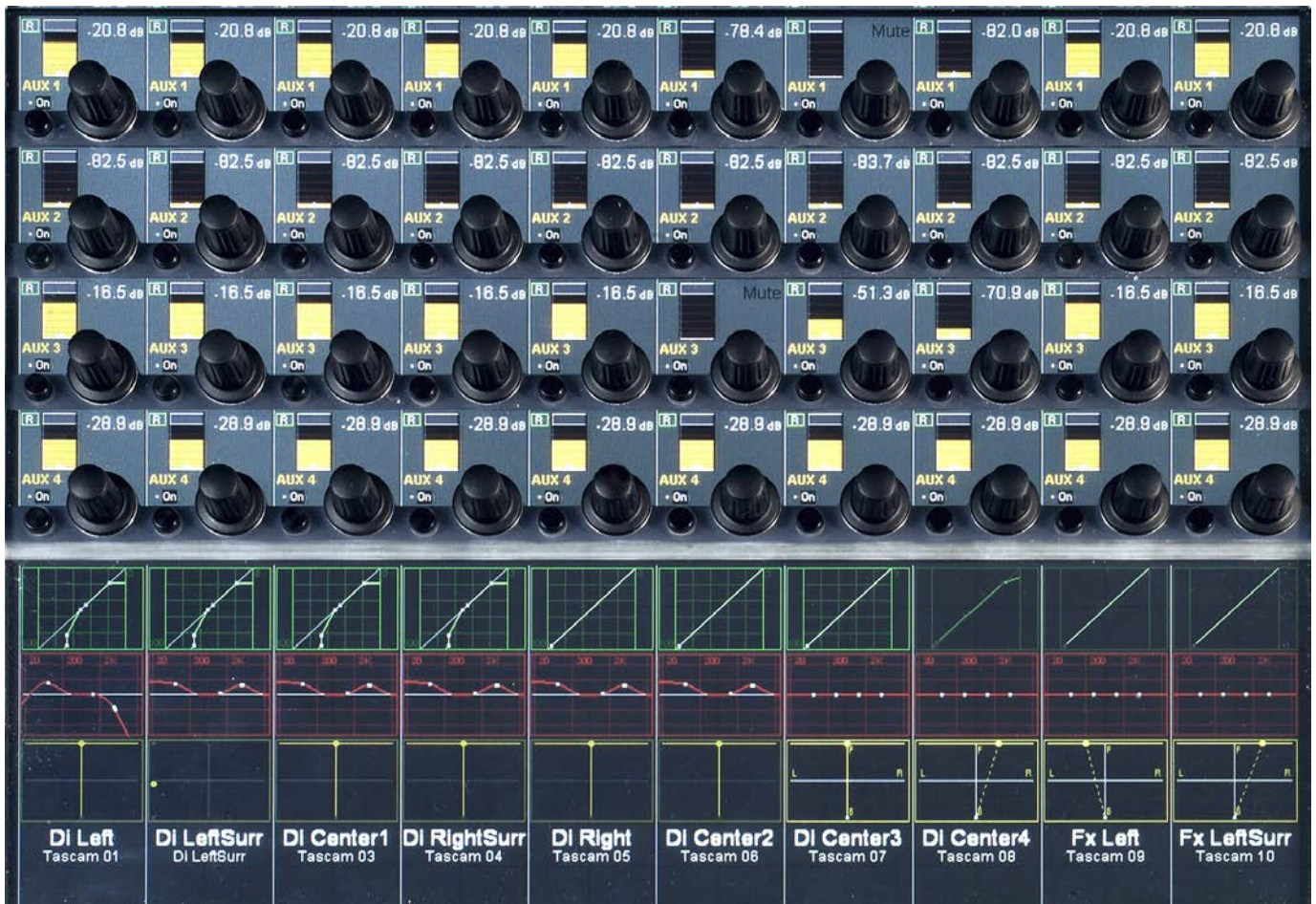

The touch screen area can also be used for indication and operation of bus assignment; this display will vary according to the actual configuration loaded.

Bus Assign Overview:

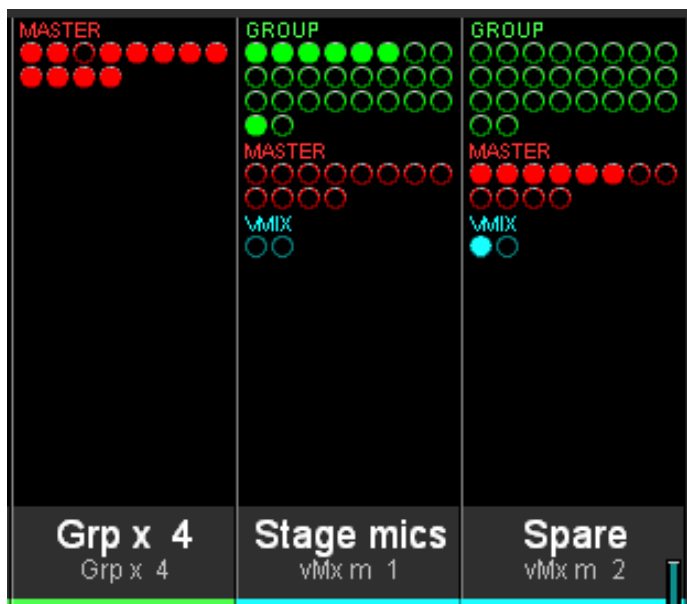

Local Views By touching the graphics shown below the Vistonics® rotary controls, the whole parameter set of that specific curve is displayed, also covering some of the neighboring channel strips. It is also possible to touch any two curves in one bay in order to display both at the same time. The example below shows the complete dynamics section of the leftmost channel (the small dynamics view is highlighted), overlaid to a global AUX view.

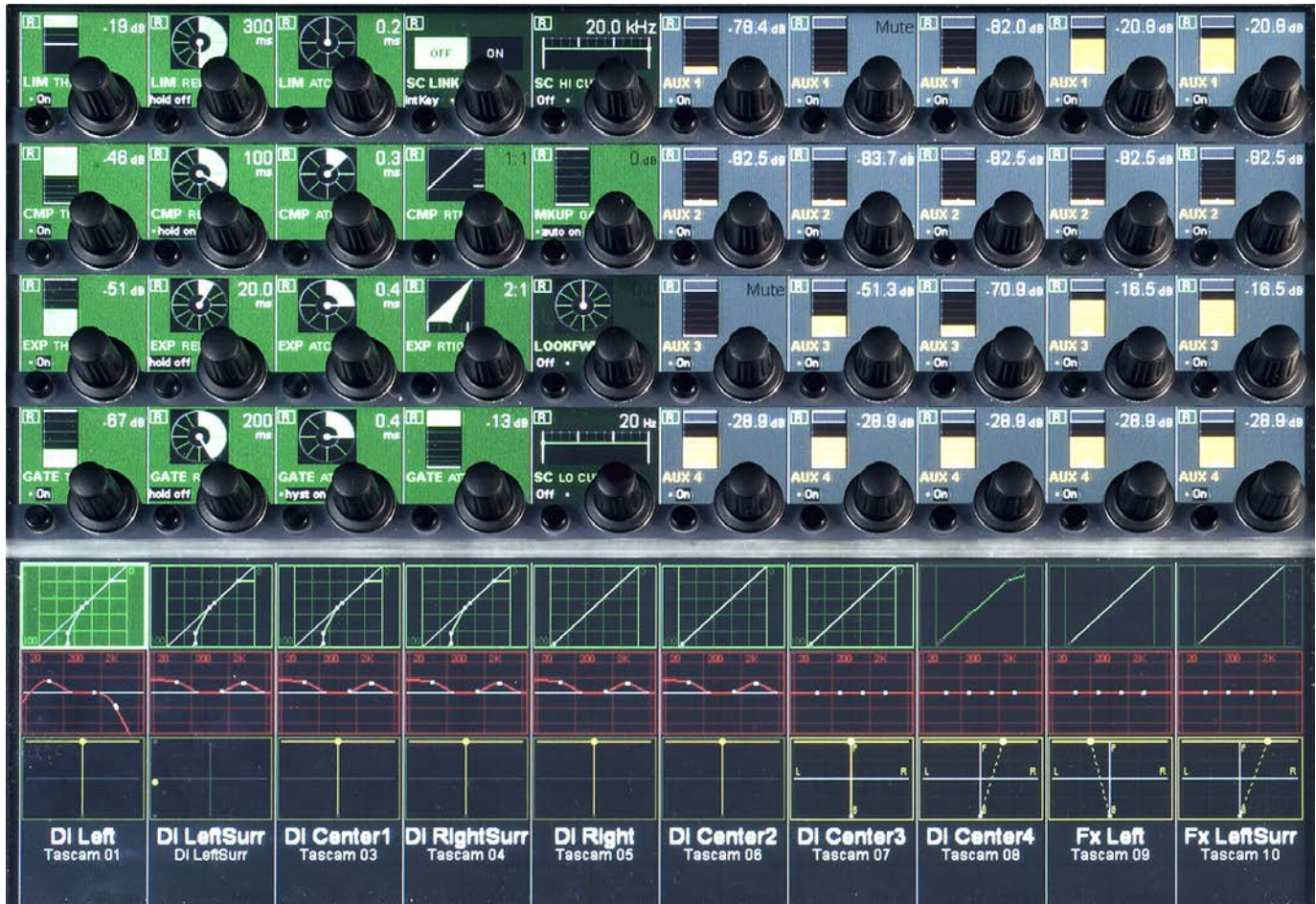

This philosophy is completed by three hardware keys underneath the Vistonics® display, showing different combinations of parameters as well as the bus assignment of that specific channel, covering the whole Vistonics® area.

Bus Assign View: (here, channels can directly be assigned to a bus)

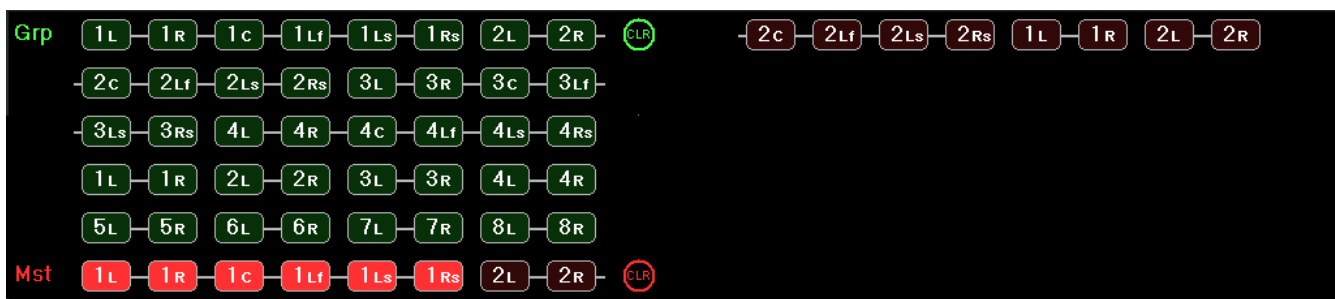

1.1.2 Momentary/Latching Key Activation ⊕

A lot of key presses during console operation are repetitive in order to compare settings or to make quick checks for monitoring purposes. The Studer Vista consoles have reduced the amount of required key presses tremendously by incorporating a special logic for these cases: The Studer Vista control surface distinguishes long and short key presses and reacts differently in both cases: Pressing and holding a key will automatically reverse its activation upon release of the key – this is, however, applied only where appropriate. All keys featuring momentary/latching activation are labeled with a ⊕ symbol throughout this manual.

For example, holding down a MUTE key for one second will automatically unmute the signal again upon release. Further examples are ON/OFF switching of audio functions (EQ, filters, dynamics), PFL/SOLO as well as most of the monitoring functions: soloing different loudspeakers, muting loudspeakers, selecting alternate loudspeaker sets, etc. Keeping a monitoring source key or loudspeaker set key pressed will automatically go back to the previous selection upon key release. If you want a switch to be activated continuously, just press the key and release it immediately, without holding.

This automatism also works on view changes: Pressing and holding an EQ graphic will make all its parameters accessible for as long as the graphic on the screen is being touched. However, it will disappear immediately when the graphic is untouched. The same thing is possible for global view changes: Quick checks of bus assignments or auxiliary levels are as fast as never before.

This philosophy has also the advantage of not having to remember the last settings or views. The console remembers it automatically.

Note: The threshold time for the momentary/latching distinction is adjustable in the Graphical controller's 'Vista Desk Settings' screen.

1.1.3 Ganging

On top of grouping certain channels together in a way commonly known as VCA groups, Studer Vista has the ability to link multiple channels temporarily together and let them behave like one single channel. Such a link is called a Gang. It co-exists with VCA style groups (Control Groups) and is only a momentary help to influence multiple channels at the same time. A gang is created by pressing and holding one LINK / SEL key on one channel while the same key on a second channel gets pressed. This will link all channels between the two. By using the MULTI SEL key it is possible to select or de-select any channels on the surface without having them next to each other. The MULTI SEL key acts much the same as the Ctrl key on a standard PC keyboard.

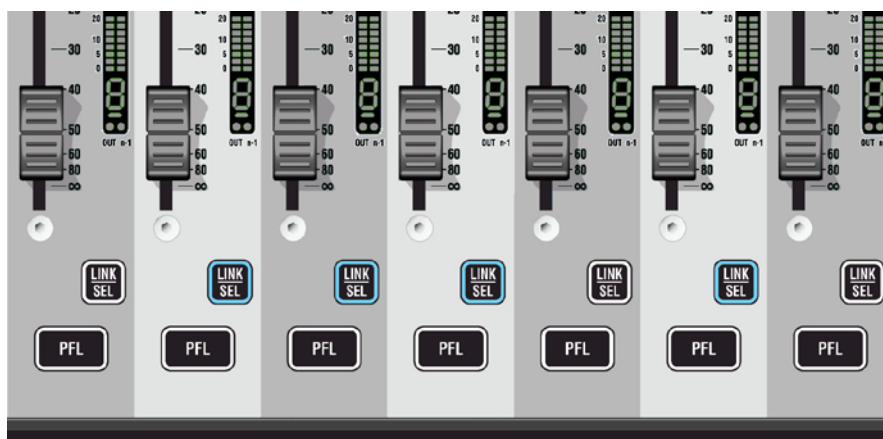

A gang is simply canceled by pressing any LINK / SEL key on the console again. Please note that there is always *one* channel selected.

Temporary de-activation of a gang is done by simultaneously touching identical control elements (e.g. fader or rotary encoder) of *two* channels within a gang.

Typical Applications

- Trimming of some faders or auxiliaries by changing the corresponding control on any of the channels
- Copying a certain setting to multiple channels by pasting the value to any of the ganged channels
- Changing a bus assignment on all the ganged channels by changing it on one of them
- Changing dynamic automation modes on the whole gang.



Basically any operation on one of the ganged channels will influence all of them. Changing switches will *overwrite* the same switch on the other channels, while adjusting a audio function with a certain range will adjust all other channels in a *relative* manner. Setting all channels to the same value is accomplished by a copy/paste operation on one of the ganged channels.



Setting Up the Console

For setup application there is a fast way to link all channels of the same type together. Pressing LINK ALL followed by pressing the LINK/SEL key of one channel will gang all channels of that very same type together (e.g. all input channels). The gang may exceed the visible channels and may also contain channels in other sections. While having that gang active, you may setup your console within seconds: Changing bus assignment, clearing one channel or copy/paste certain values to any of these channels.



1.1.4 Copy/Paste

Copying certain audio settings across the console is made very fast and easy: There is a set of global channel processing keys in the center of the desk.

- Select the source channel.
- Set the desired processing parameters.
- Press the relevant  copy/paste key next to the processing block concerned to copy the source data into the clipboard.
- Select the target channel(s). A single channel may be selected by touching the relevant Vistonics icon or pressing the LINK/SEL key. Pressing and holding the LINK/SEL key and then pressing additional LINK/SEL keys will create a link group.
- Press the relevant  copy/paste key will paste the parameter data from the clipboard into the selected channel(s).

There is also a special  A (copy/paste all) key for copying a whole channel including bus assignment. The  undo/redo key comes in handy to undo the last paste or clear function on each channel separately. Pressing this key after an undo operation again will redo the last copy.

Note The  undo/redo key can be used momentarily (long press) in order to compare settings on a channel:

- 1 Press the  copy/paste key twice in order to ‘memorize’ the current setting (i.e., by pasting it to itself)
- 2 Adjust the audio function to an alternative setting
- 3 Press  undo/redo multiple times (either short or long) in order to compare the two settings.

Half-Lit Keys Whenever the console is waiting for a key press in order to finish a function, it will illuminate all possible keys by half. This is a guide for the user – so he can select one of these keys, or reverse the function by pressing the first (fully lit) key again. A timeout applies if none of the half-lit keys are pressed within a given time frame. Timeout duration is adjustable in the ‘Vista Desk Settings’ menu on the GC.

Examples:

LINK ALL > LINK/SEL,

Setup of control groups, etc.

1.1.5 Scrolling

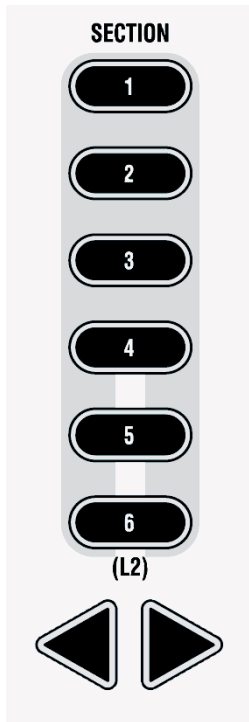

Most Vista installations will have more channels available in the DSP core than there are physical faders on the console surface. Most manufacturers deal with that fact by introducing ‘layers’: The console surface can be switched in order to show the different layers, all of which making all DSP channels available to the user. The Vista operating philosophy has modified this concept. Rather than thinking of layers sitting on top of each other, we think of the layers being arranged on a horizontal line. The ‘Layer’ is now called ‘Section’. The six sections are next to each other on an imaginary horizontal line, as indicated by the ‘Section Navigator’ keys in the control bay.

As long as the user wants to switch to a specific section, there is no difference in operation to the ‘layer’ concept. Changing to another section is accomplished by pressing one of the corresponding keys in the SECTION NAVIGATOR area of the control bay (below right), or by pressing the arrow keys located in each fader bay with SCROLL: SECTION set to ON (below left).

Information on which section is currently displayed is given by the illuminated keys. Looking at the Graphical Controller with the ‘strip setup’ screen in the foreground will also indicate the currently displayed section by putting a dark background to the displayed channels.

The Difference from the Layer Concept

Rather than just switching to another section, it is possible to scroll through the sections by pressing any arrow key (for this purpose, SCROLL: SECTION has to be OFF on the fader bays). This will make the physical surface scroll through all sections with a step size of one bay (10 channels). It is therefore possible to move any channels close to the position of the operator, allowing him to stay in the ‘sweet spot’ at all times. This concept can also be imagined like moving a chair in front of an analog console. On Studer Vista, you move the surface of an imaginary console six times larger than the physical console. Which DSP channel is shown where on the desk is defined in the ‘strip setup’ dialog in the Graphical Controller (refer to [chapter 4.4.7](#)).

Desk Navigation Example

Step 1

Let’s assume a desk with 32 faders (between 22 and 42 possible in steps of 10). Since the desk can jump to six sections, this user can operate up to 6×32 DSP channels. *Please note that it is possible to have the same DSP channel visible in multiple places within the six sections.*

The user defines the order of the 186 DSP channels in the strip setup dialog box in the GC. There he will find six empty sections with 32 placeholders, each for a channel assignment. The definition will most likely be made in such a way that the user starts with a new section when he starts with new channel type, as shown below.

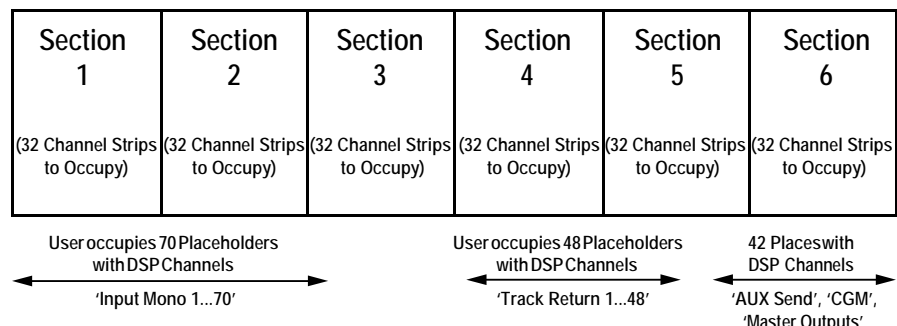

Step 2 The user can now navigate through the ‘virtual surface’ (6 sections wide) in two ways: Either he jumps to a specific section by pressing the corresponding key in the control bay, or he scrolls from the present position to the destination by pressing one of the arrow keys (< and >) in any of the bays. Pressing one of these arrow keys will virtually move the physical surface in front of the total console (6 sections) by one bay (10 faders) at a time in the corresponding direction, like moving a chair in front of a huge console.

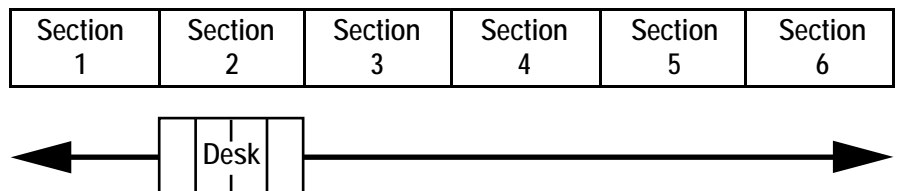

The arrow keys are located in every fader bay, and they all have the same functionality. This prevents the user from having to move to the center of the console for navigation.

1.1.6 FaderGlow™



FaderGlow provides the operator with an instant overview of the functions assigned to the faders by illuminated fader tracks. It is also possible to assign the fader track illumination freely – eight different colours are available – in order to mark important channels such as presenters, main talents and other ‘must-never-lose-their-signal’ channels.

However the red FaderGlow colour is used by the graphic EQ if switched to the faders (and if configured within the channel processing).

Once the desired channel is coloured, it can be found within a fraction of a second, even after mixing on a different layer and coming back to a channel layout that may not have been on the surface for some time. Moreover, FaderGlow allows the operator colouring entire channel groups (such as ‘band’, ‘guest’, ‘ambience’, ‘string section’, ‘rhythm section’ channels), in order to distinguish them easier and locate them faster.

FaderGlow configuration is described in the strip setup, refer to [chapter 4.4.6.1.7](#).

1.1.7 TFT Level Meters (Option)

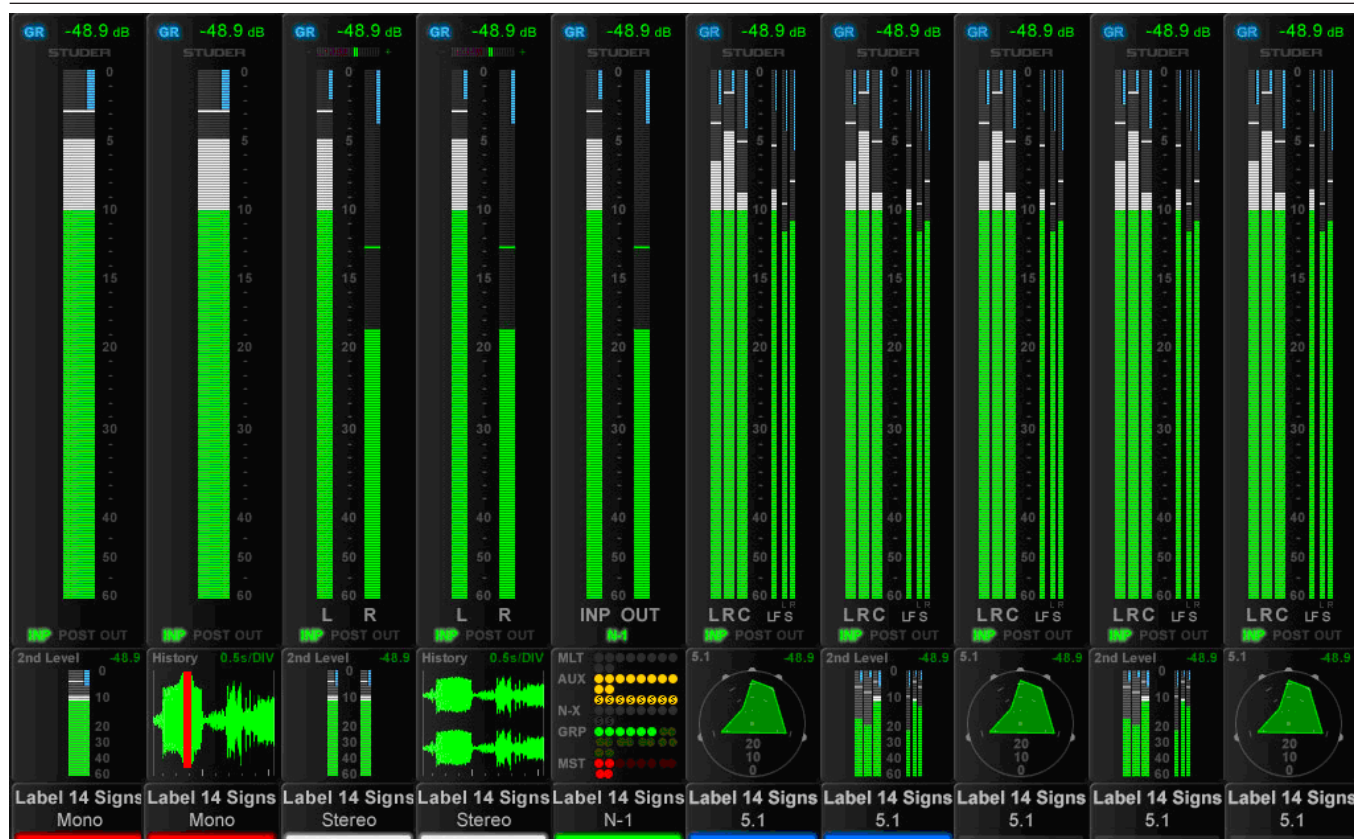

As an option, additional TFT screens may be fitted to the top of the desk to provide a full mono, stereo or surround meter for every fader on the desk. The illustration above is an example of a meter screen, with mono, stereo and surround channels and different views in the lower area – such as metering of the L2 channel, history, bus assignment and surround view. Further information is displayed as well, such as fader glow color, gain reduction, correlation for stereo signals, or surround signal type.

Normally the meter assignment automatically follows the fader assignment both for audio and for meter display type. 1., 2 or 6 green/white bars display the audio level according to the fader channel format. At the bottom of the main meter is an indication of the source of the signal in the channel path; INP = pre processing, POST = post fader, and OUT = direct output (only valid if routed to a physical port). Below the main meter is an assignable display that shows one of the following:

- Audio level monitoring of the equivalent channel on the layer 2 fader 'L2' mode (only available if 'L2' mode is enabled)
- Audio waveform display; shows the audio history which is very useful for finding clicks and overloads
- Bus routing display
- Surround vector type display (for surround channels only)

The control bay metering differs from the meter screen on the fader bays; it is mainly made to show output channels. Different meter views are available for this screen. It can be switched to a predefined meter view to see all auxiliary outputs. Or to all groups, or all programme masters, direct outs, bus outputs, N-1s, matrix channels, etc. In addition there are user pages assignable to

whatever is desired via the strip set-up. There are four configurable user page pages, one with ten slots in one row, one with 20 slots in two rows, and two with 40 half-width slots in two rows. So if calling up page four, there are 40 meters, and they can be virtually anything. The two meter slots at the right of the control bay TFT screen continuously show PFL and CR levels.

TFT meter configuration is performed in the GC's strip setup screen. Refer to [chapter 4.4.6.1.6](#).

1.2 The Graphical Controller (GC)

An important feature of the Vista Digital Mixing System is the Graphical Controller, also referred to as 'GC'. The Graphical Controller program is used for operating all mixing console functions that extend console's functionality.

Specifically, the Graphical Controller's extended functions include:

- General and channel-specific router control (defining the order of processing elements, e.g. EQ or dynamics libraries, within a channel)
- Recall and management of snapshots and cue points
- Saving of desk clipboards
- Assignment of the DSP channels to the fader strips
- Tone generator and metering control
- Control group and linkage control
- Production and Title management
- System administration

Various display windows and dialog boxes logically group the individual functions. Visual elements are optimized for simple and intuitive operation.

With the help of an easy-to-understand General Patch page, the setup of router cross points is dramatically simplified, even for large mixing console configurations. Via a Snapshot window, all mixing console parameters can be stored and recalled using mouse clicks. Some of the most important functions are also available as dedicated keys on Vista's control bay.

The concept of overall system configurability has been also adopted within the Graphical Controller application. Since most functions are arranged in overlapping windows of changeable sizes, users can set up their work environment to suit their specific requirements for each recording or production session. These settings can be saved and recalled at any time, allowing for fast and application-oriented operation of the Vista system.

1.2.1 GC Screen Examples

Internal Routing Matrix Control

The Channel Patch screen is an audio path-oriented view for controlling the routing of a particular channel, and is used to set up the sequence of channel processing blocks (EQ, Insert, Delay, etc.) and metering locations within the signal path, as well as defining the direct out signal. This screen also displays the connections made to the channel's various inputs and outputs. By double clicking on one of these display boxes the system will go directly to the associated connection in the General Patch. The Channel Patch also includes labeling and dynamics link facilities.

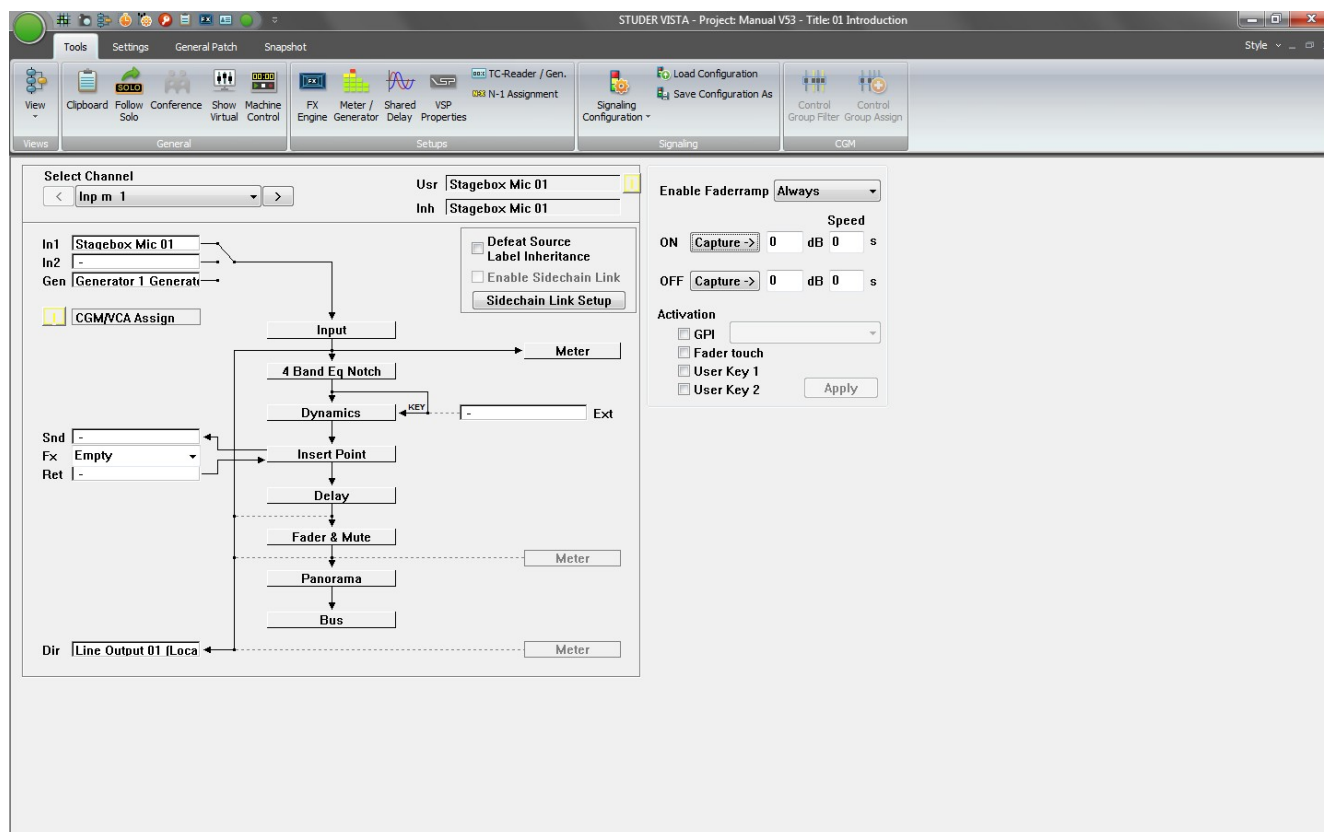

Within the General Patch window, the various cross point routing of sources and targets (destinations) is displayed. For example, it will show which audio signals (AES/EBU in, Direct outs, etc.) connected to the DSP sections are assigned to the corresponding channels and outputs (Input channel, MADI out etc.). These connections are stored within Snapshots and Presets. The sources and targets can be identified by Fixed, Device, Inherited, or User labels.

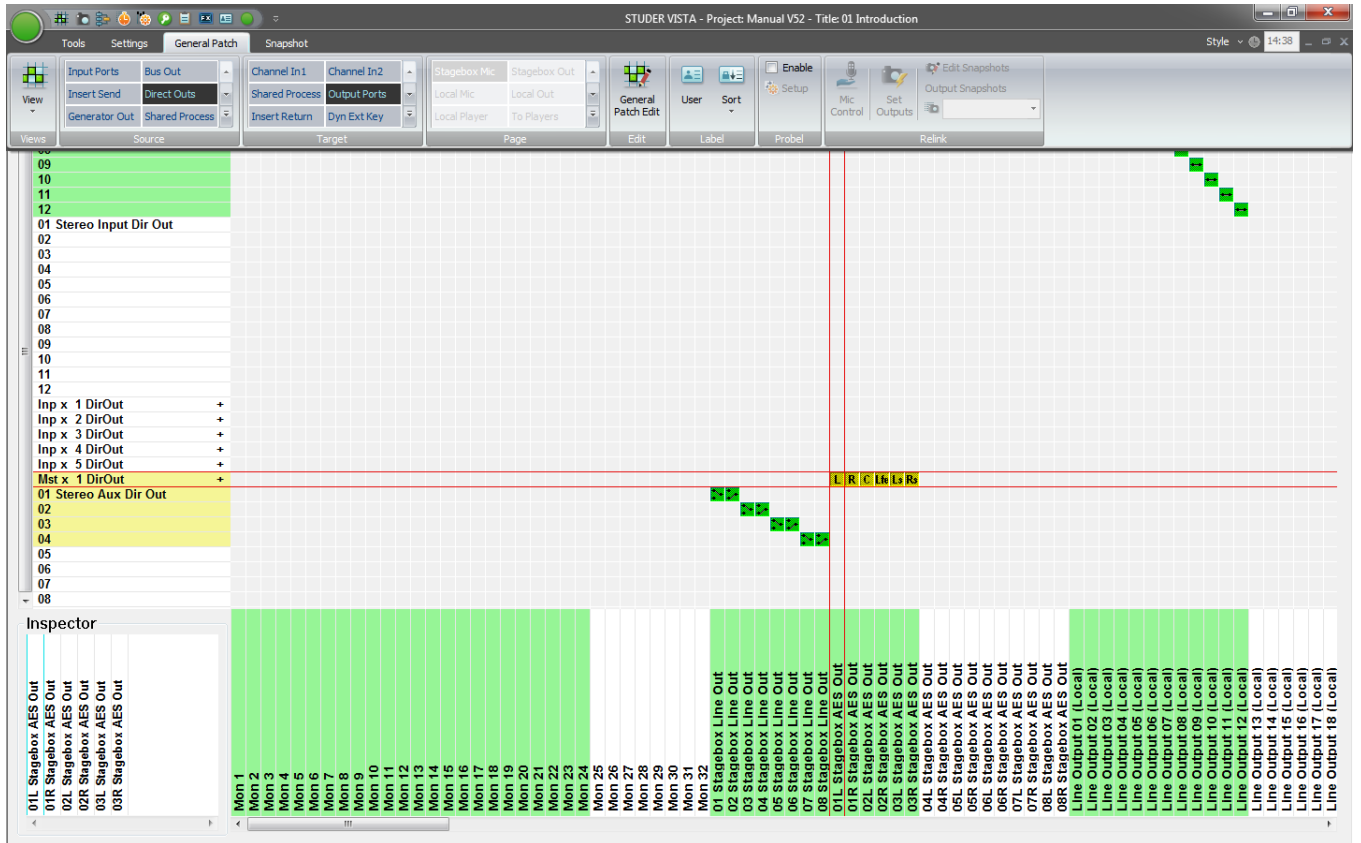

Snapshot Functions Display and control of snapshot settings (in other words, complete ‘pictures’ of the operating desk’s controls and of the console’s internal settings) and factory/user presets provide basic working templates.

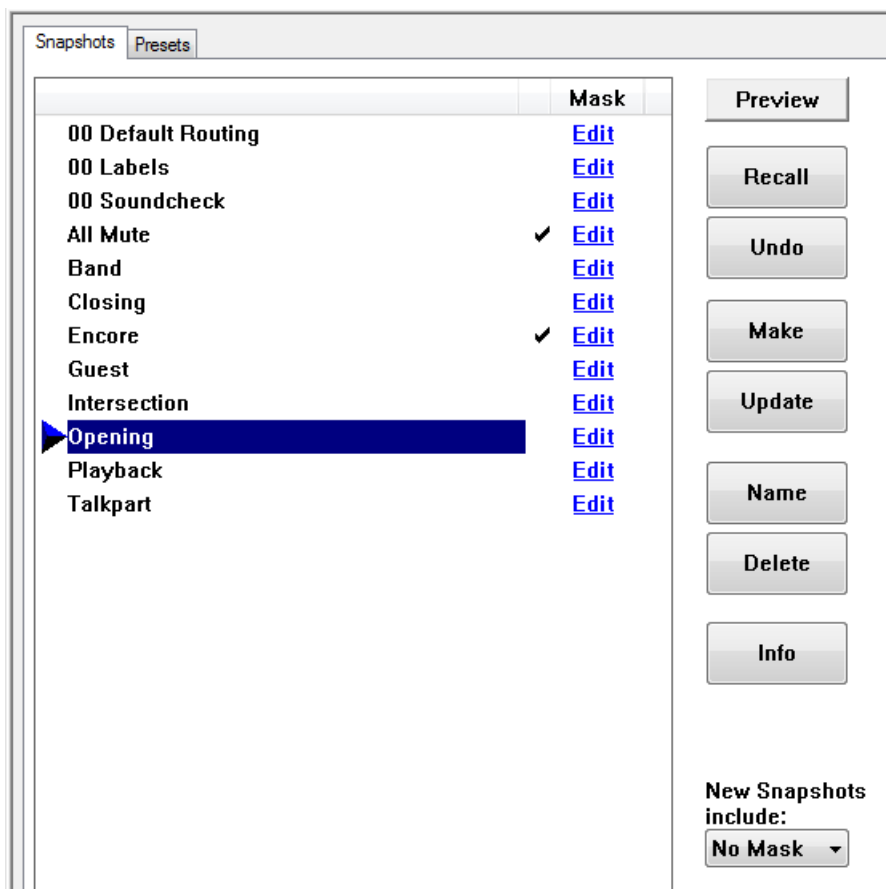

Control of snapshot/preset filters and channel protection is achieved via separate windows:

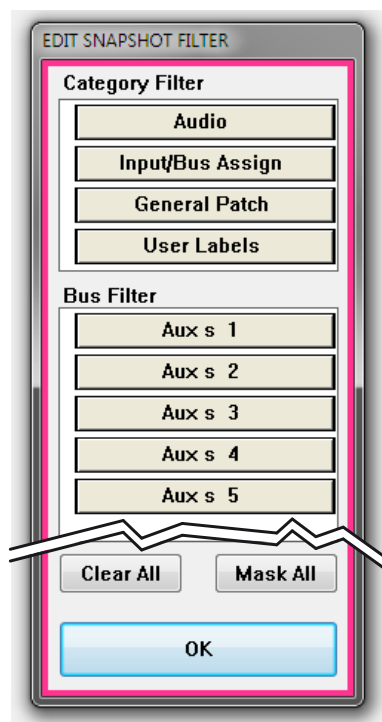

1.3 Channels, Routing, and Buses

Processing blocks, such as equalizer, dynamics, delay, etc., can be configured for all channel types.

Input Channels Vista's digital routing matrix is located between the console's physical inputs and the actual DSP channels. This topology means that the physical analog and digital inputs can be assigned to any console channel via the General Patch page on the Graphical Controller. The patch setup forms part of each individual snapshot, and can be saved, updated and recalled within the Snapshot/Preset system.

Output Channels This also applies to the outputs. On the General Patch page, each channel's output can be selected and sent to any analog or digital output destination.

Auxiliaries The number of stereo or mono AUX sends is fully configurable. The users can establish the number and type of AUX sends they would like to use. The AUX master channel can be equipped with the same selection of processing blocks such as equalizer, dynamics, delay, and more.

Clean-Feeds/Mix-Minus (N-1/N-X) Clean-Feeds/Mix-Minus or N-1/N-X buses can be set up in stereo or mono, and are configurable in number.

Multi-track and Group Routing Full multi-track and group routing can be configured.

Solo Modes Each channel features a Solo and a PFL Switch. Depending upon the mode selected within the Control Bay the SOLO key is active as SOLO or Solo-In-Place. Clearing these buttons can be achieved by opening the corresponding fader in case 'PFL BC' (Broadcast) is active. A very handy PFL/Solo Reset is provided to disengage any solos regardless of where they are engaged on the console. This eliminates the need to 'search' for solos with large console configurations. A key to define certain channels to be safe from being muted in 'Solo-In-Place' mode is also provided. This set will be stored with each title.

1.4 Processing Blocks

- Equalizers** Four fully parametric bands are provided on the Vista. Each band, which can be switched in and out independently, extends from 20 Hz to 20 kHz, with a ± 18 dB gain range. The EQ features a psycho-acoustically corrected frequency response for high frequencies, similar to well-known analog EQ designs. The two mid-bands can be switched between constant-Q and constant-range modes. The high and low frequency bands can also be switched to shelving mode. A second EQ type is available (defined in the Configuration Tool), which features an additional Notch filter. Since SW V4.8 an additional, 30-band BSS graphic EQ is available; its settings may be indicated and adjusted by 30 of the desk faders very simply. If required, both the parametric and the graphic EQ may be configured within the same DSP channel.
- Filters** Low-cut and high-cut filters are provided, with cutoff frequencies that are variable between 20 Hz and 20 kHz, and slope selections of 12, 18, or 24 dB/octave. In addition, an analog low-cut filter with a cutoff frequency of 75 Hz and a slope of 12 dB/octave is available in the D21m Mic/Line preamplifier.
- Dynamics** The Vista dynamics processing consists of four parts: Limiter, Compressor, Expander, and Gate. To avoid pumping and modulation, the dynamics processing sections feature high sampling rate transient detection. Distortion artifacts are minimized through selectable, program-dependent attack and release times. The Vista's dynamics feature a side-chain input that can be used with or without HP/LP filters. A unique 'look forward' function is also featured. If desired, this allows the entire transient portion of a waveform to be affected when using the limiter/compressor or to be passed when the expander/gate is used.
- Soft Clip** In addition, a soft clip function can be activated in the D21m Mic/Line preamplifier.

1.5 Monitoring and Communication

- Monitoring** The Control Room (CR) monitoring section provides control of up to two different speaker systems (one multi-channel and one two-channel stereo) and 16 source selectors. All internal digital sources can be assigned to any of the source selector keys. A headphone socket is also supplied for use within the control room. The Studio Monitor is configurable in the same way as the CR monitor section, although only one stereo loudspeaker pair is supported.
- Talkback** An extensive talkback system is implemented within the Vista. The talkback source can be either the built-in desk-operator microphone or an external producer microphone. Several destinations, such as buses, direct outputs, auxiliaries, groups, and master outputs are available block. Each channel is fitted with a talkback key that activates talkback to the direct output of the corresponding channel and, if the channel is an N-1 owner, to the N-1 output. *Refer to the talkback and signaling block diagram on the next page for details.*

Talkback and Signaling Block Diagram **VISTA 5 BLACK EDITION** Using D21m GPIO Cards

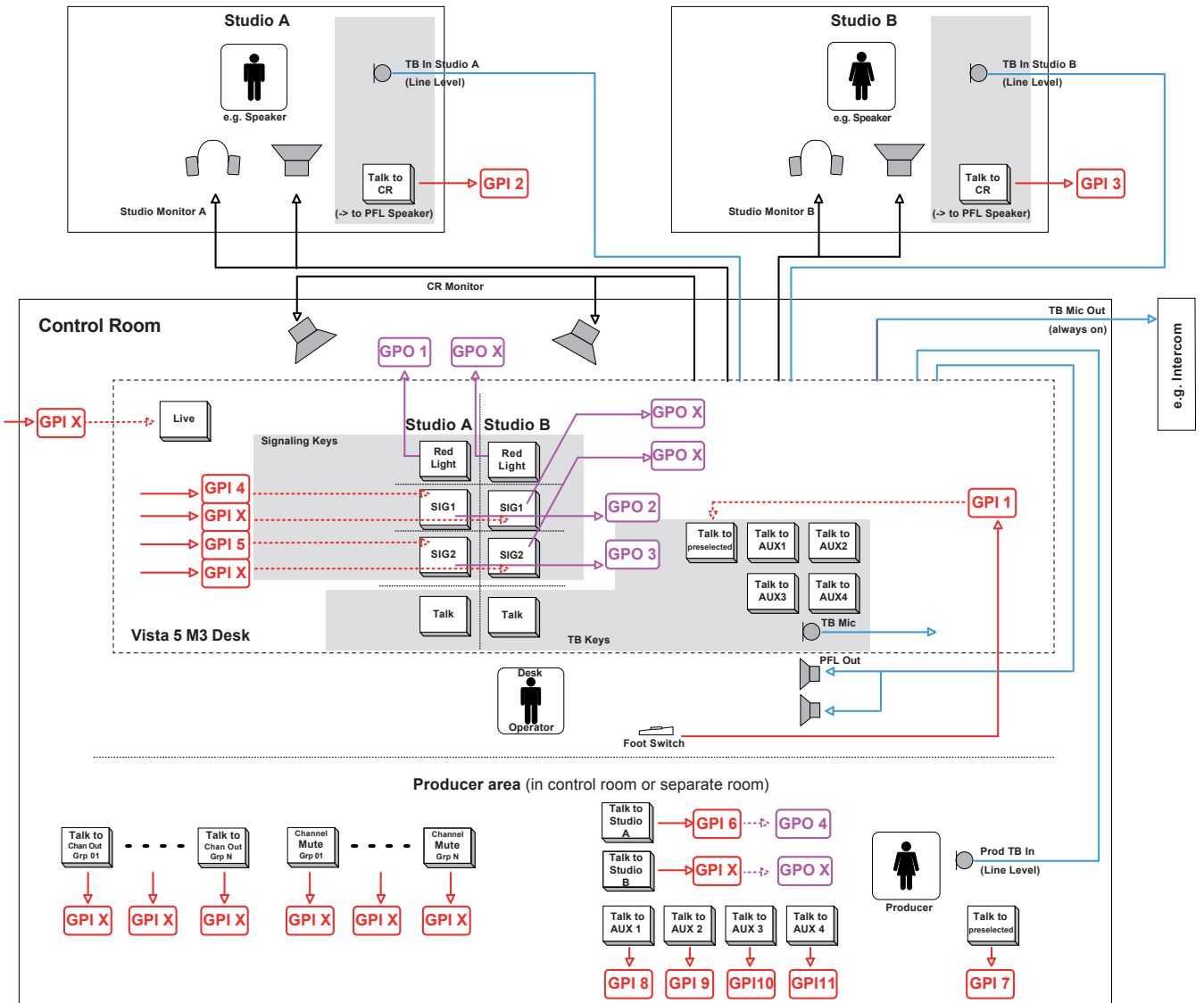

Legend:

- GPI 1 = GPI already configured in .ini files
- GPI X = GPI prepared to use, but not assigned to signaling card. Can be configured in .ini files
- GPO 2 = GPO already configured in .ini files
- GPO X = GPO prepared to use, but not assigned to signaling card. Can be configured in .ini files

Already configured:

- GPI 1 Footswitch to talk to preselected
- GPI 2 Talk to CR from Studio A
- GPI 3 Talk to CR from Studio B
- GPI 4 Signaling 1 Studio A
- GPI 5 Signaling 2 Studio A
- GPI 6 Talk to Studio A
- GPI 7 Talk to preselected
- GPI 8 Talk to AUX s 1
- GPI 9 Talk to AUX s 2
- GPI 10 Talk to AUX s 3
- GPI 11 Talk to AUX s 4
- GPO 1 Red light Studio A
- GPO 2 Signaling 1 Studio A
- GPO 3 Signaling 2 Studio A
- GPO 4 Talk to Studio A

1.6 Static Automation Functions

Snapshots An unlimited number of snapshots can be captured, stored, and recalled for each Project Title. All control parameters of the console are stored in the snapshots. When a snapshot is recalled, the console typically requires 120 ms to fully reset itself. Snapshots recalls can be done with snapshot filters active, protecting certain console parameters from being changed by the recall. Extensive editing functions allow modifying snapshots after or during a live show. Besides absolute protection of certain parameters it is possible to trim parameters relative to their stored values rather than letting them totally unmodified. Recalling a preset however, will ignore any snapshot filters which may be active and bring the console into a defined audio state.

Copy & Paste Clipboard The Vista System supports copy and paste of some or all channel settings to one or more other channels. This ability streamlines the set-up of the console when an operator is starting from scratch with a new layout. However, if starting from a clean slate is desired, clearing all or some of the parameters is possible as well.

1.7 Input Channel Block Diagrams

Block Diagram of a Typical Mono Input Channel:

Please note that, essentially, all channel types have the same structure, regardless of the type (input, AUX, group, master, etc.)

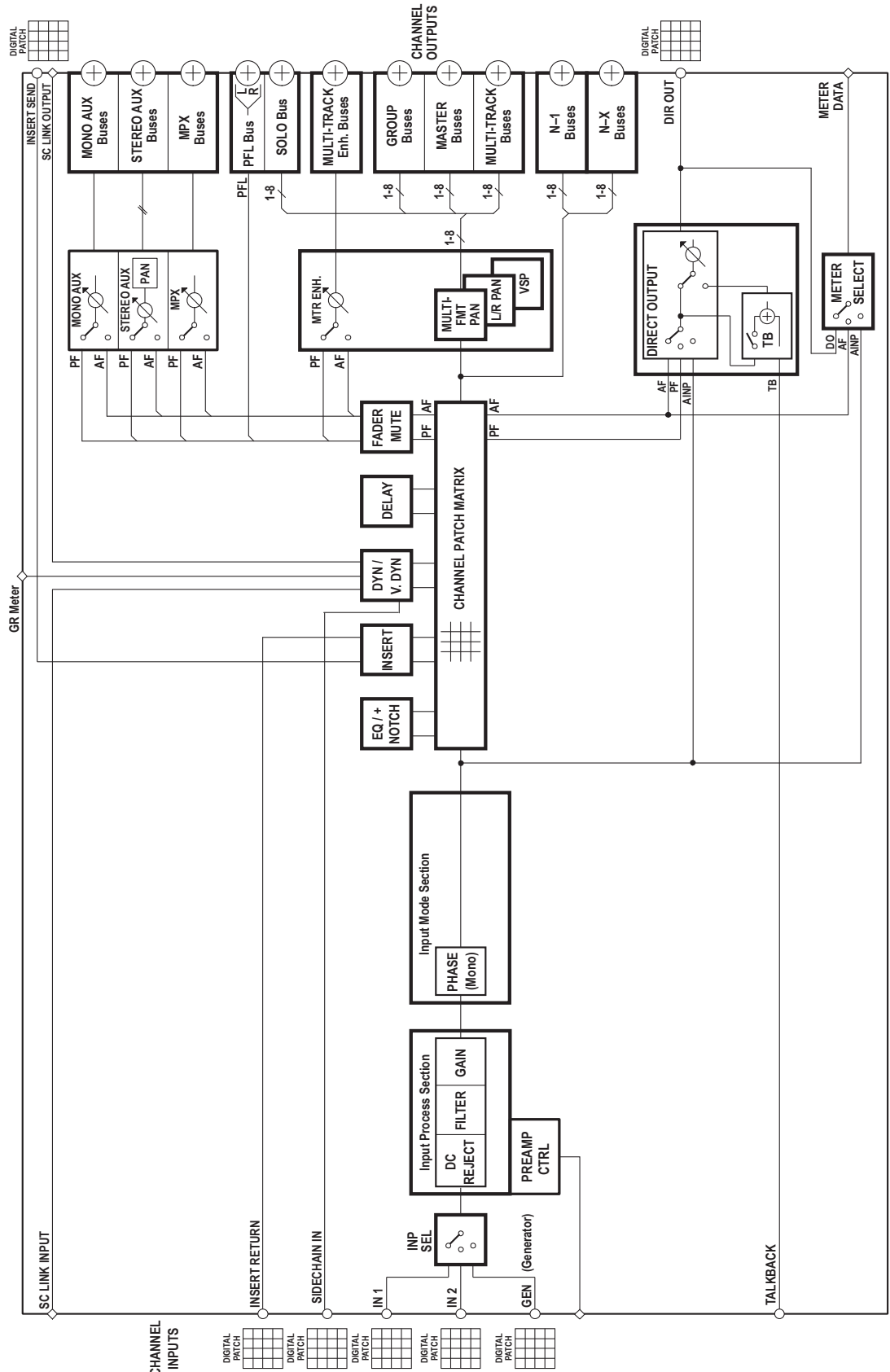

Block Diagram of a Typical Stereo Input Channel:

Please note that, essentially, all channel types have the same structure, regardless of the type (input, AUX, group, master, etc.)

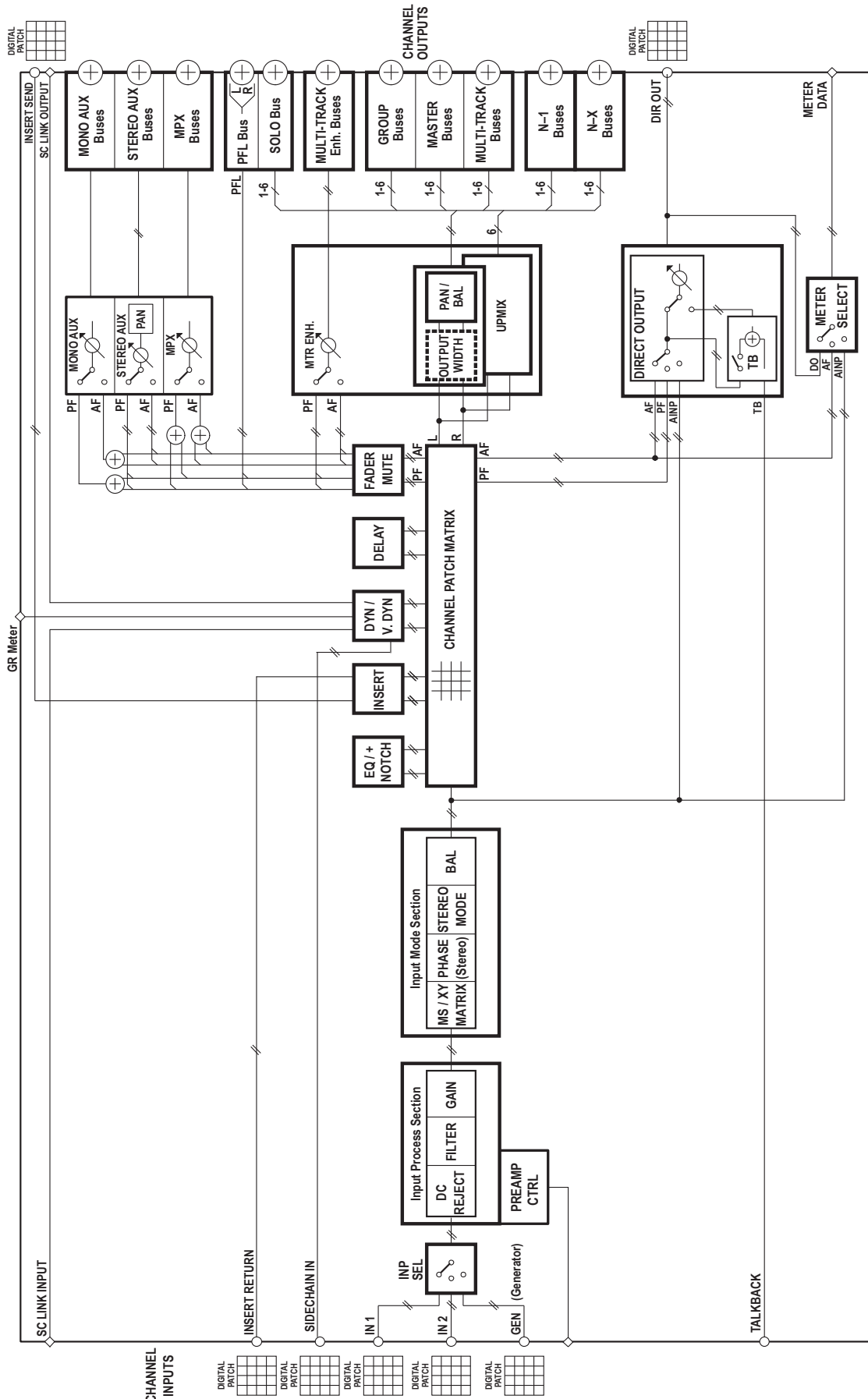

Block Diagram of a Typical 5.1 Input Channel:

Please note that, essentially, all channel types have the same structure, regardless of the type (input, AUX, group, master, etc.)

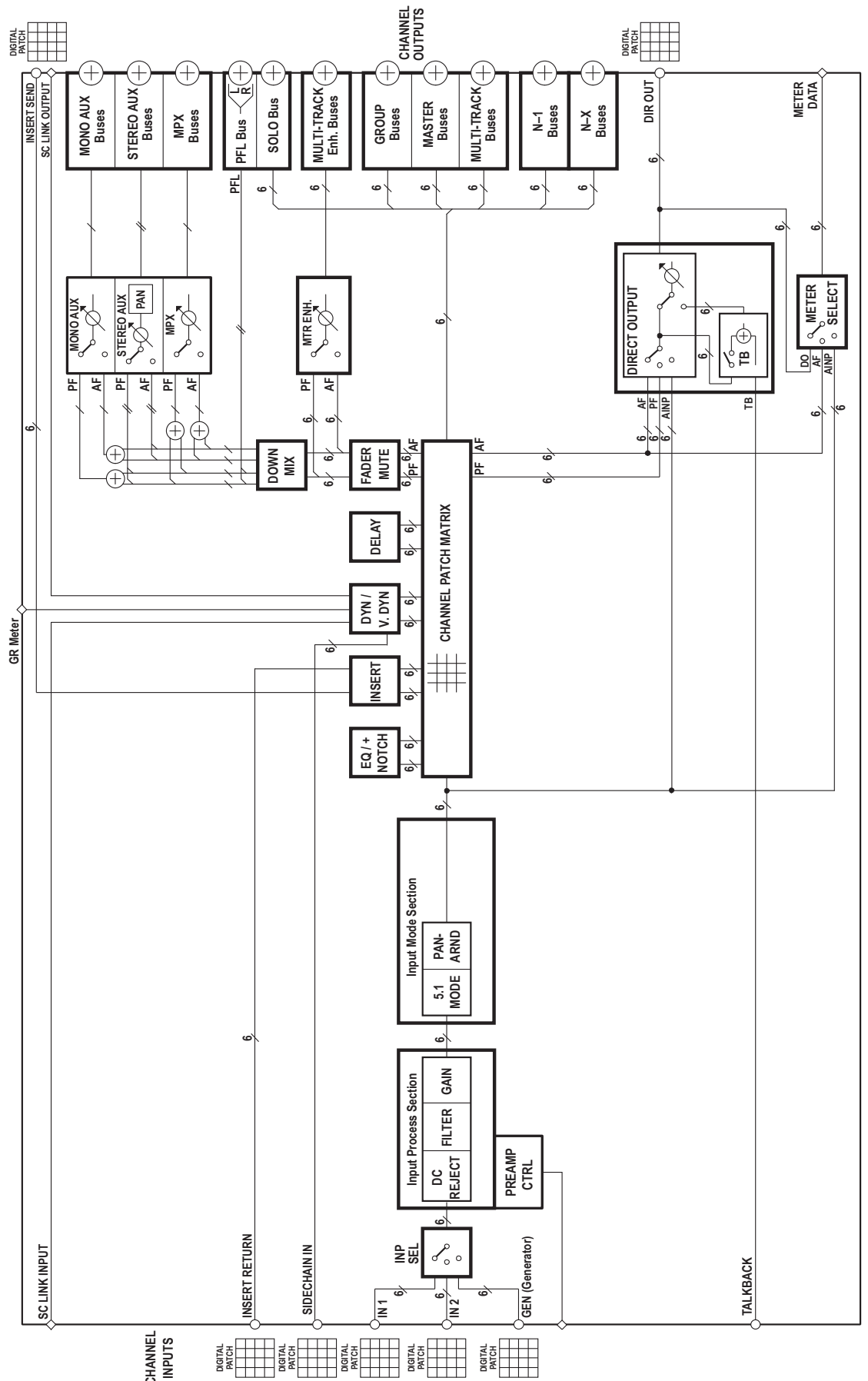

CHAPTER 2

| | | |
|----------|---|----------|
| 2 | Vista 5 BE Desk Operation..... | 3 |
| 2.1 | Vistonics® Operation / Local Views | 4 |
| 2.2 | Fader Area | 6 |
| 2.2.1 | Channel Meters | 7 |
| 2.3 | Channel Selection..... | 8 |
| 2.4 | Global Views..... | 9 |
| 2.5 | Central Channel Processing Keys..... | 10 |
| 2.6 | Control Bay Details | 13 |
| 2.6.1 | System/TB/Headphones..... | 13 |
| 2.6.2 | Loudness Metering..... | 14 |
| 2.6.3 | Control Room Monitoring..... | 15 |
| 2.6.4 | Studio Monitoring | 17 |
| 2.6.5 | Monitoring Source Selection..... | 18 |
| 2.6.6 | Option (Spare Keys)..... | 19 |
| 2.6.7 | Custom Panel Keys | 19 |
| 2.6.8 | Talkback Control..... | 19 |
| 2.6.9 | Control and Mute Groups..... | 21 |
| 2.6.9.1 | Control Group Setup | 21 |
| 2.6.9.2 | Mute Groups..... | 21 |
| 2.6.9.3 | Mute Group Setup | 22 |
| 2.6.9.4 | Off-Air Conference | 23 |
| 2.6.10 | GC Shortcut Keys..... | 24 |
| 2.6.11 | Hardware Keys..... | 25 |
| 2.6.12 | Joystick..... | 26 |
| 2.6.13 | Fader Page Navigator | 27 |
| 2.6.14 | Grand Master Faders | 28 |
| 2.6.15 | Output Views / FOLLOW | 29 |
| 2.6.16 | Contribution Access | 31 |
| 2.7 | Fader Bay Details | 33 |
| 2.7.1 | Channel Control | 33 |
| 2.7.1.1 | Two-Layer mode..... | 33 |
| 2.8 | Clipboard Libraries..... | 35 |
| 2.8.1 | Clipboard Library Window | 35 |
| 2.8.2 | Paste to Clipboard Library | 36 |
| 2.8.3 | Copy from Clipboard Library..... | 36 |
| 2.8.4 | Rename/Delete a Clipboard Library File | 37 |
| 2.8.5 | Clear the Display..... | 37 |
| 2.8.6 | Update a Clipboard File | 37 |
| 2.8.7 | Storage Format | 37 |
| 2.8.8 | Import a Clipboard File from Another Library..... | 37 |
| 2.8.9 | Where are Clipboard Libraries Saved?..... | 38 |
| 2.9 | Console Illumination | 38 |
| 2.10 | Optional TFT Level Meters | 39 |

| | | |
|--------|------------------------|----|
| 2.11 | Virtual Vista | 42 |
| 2.11.1 | Screen Layout..... | 44 |
| 2.11.2 | Fader Bay View..... | 45 |
| 2.11.3 | Control Bay View | 46 |
| 2.11.4 | GC View..... | 48 |

2 VISTA 5 BE DESK OPERATION

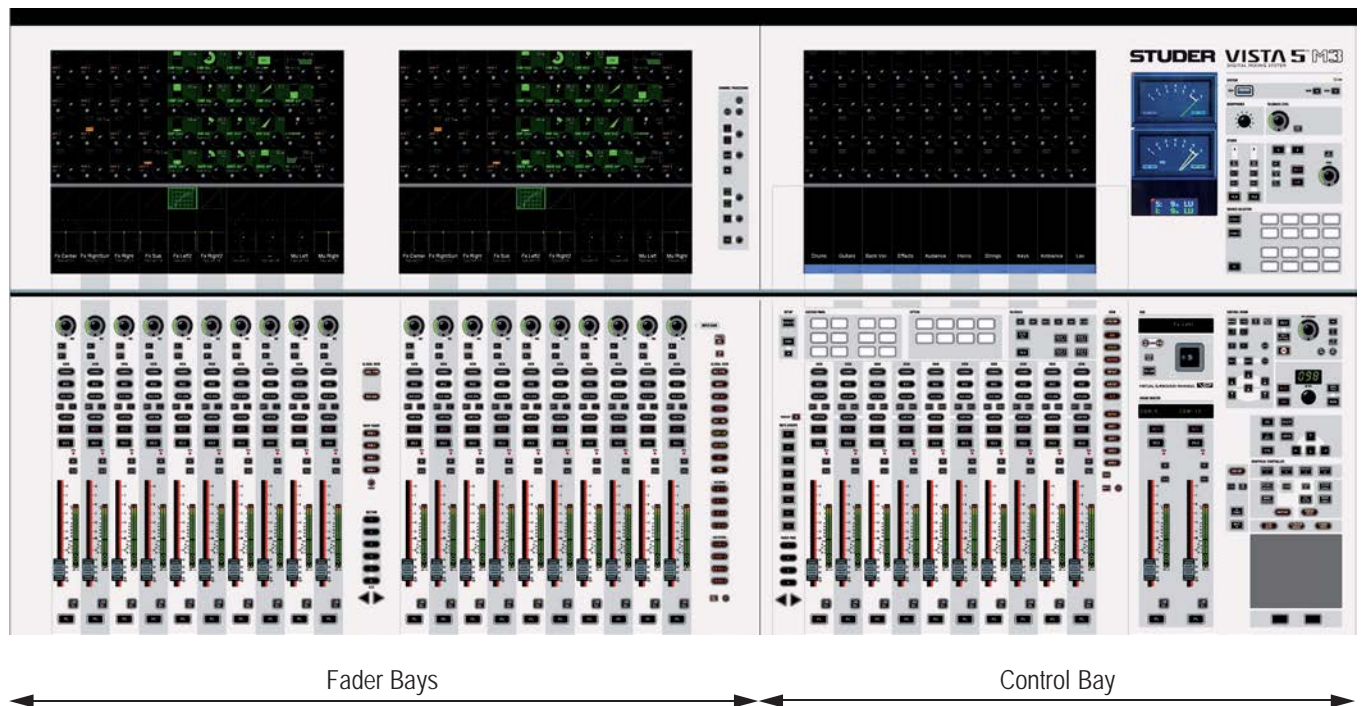

The desk consists of two types of bays: From one to three fader bays (ten faders each), and one control bay (ten faders plus two 'grand master' faders). For compactness, two fader bays are combined in a single fader bay module, as shown above. This is the standard layout of a 32-fader console. The 42-fader version has one more 10-fader bay added at the right of the control bay, and the 22-fader version just has one 10-fader bay. Every bay features a Vistonics screen with 40 rotary encoders in its upper part and a touch screen surface below them.

The fader bays contain the console channel strips with rotary controls, faders, keys, and meters. Ten strips are located next to each other in one bay. They may be assigned to any DSP channel.

The control bay hosts the global desk operation controls, such as monitoring, talkback, joystick and touchpad. It can also be used as fader bay in order to control any DSP channel.

The desk contains the control system and their power supplies. A keyboard is available in a drawer below the control bay.

An external TFT screen may be mounted on the rear of the desk in order to display the Graphical Controller (GC) screen (refer to chapter 4). This screen may be attached to the desk in one of two locations: Exactly above the control bay or at the right of the console. If the TFT level meter option is installed, this GC screen is already integrated into the meter bridge.

- ⊕ Each key marked with this symbol can be activated either momentarily or latching. Pressing this key for a short time will make it latching. Holding it down for a longer period of time will reverse its function automatically upon key release.

2.1 Vistonics® Operation / Local Views



[A] ☉ Vistonics® Rotary Control Area

Each rotary control is grouped with a key to form a control element. These control elements are sometimes used in a channel-related manner, dedicating four of the control elements to each channel strip; sometimes, neighboring channels are used in order to show a complete parameter set of one single channel. This is the case when touching any graphical display of EQ, dynamics, or pan, but also when activating **VIEW: MISC** or **VIEW: CHANNEL**.

[B] ☉ Vistonics® Touch Screen Area

Graphical indication of dynamics, equalizer and pan. Touching the graphics will open up all corresponding parameters on the rotary control area. This section is also able to display bus assignment. Two modes are available: Bus assignment as a 'bubble view' to give an overview over the whole console, or bus assignment of a specific channel (one per bay). The graphical pan display may vary depending on the configured panning function or format. (2-CH Stereo Pan, Multi-format Pan, VSP).

[C] Generic Display Area

This area is used to display all sorts of information. The following is continuously displayed:

- Inherited label (top line). This corresponds to the USER label of the connected source (can be edited in the GC's Global Patch window). This label is normally changing between sessions (e.g. 'Lead Vocal').
- Switchable label (second line). Normally this is set to USER labels, but might be changed by pressing **GLOBAL VIEW: LABEL TYPE**. The displayed label toggles between showing: Channel number (also referred to as Fixed Label, e.g. 'Inp m 1'), USER label (also referred to as Device Label, e.g. 'Tascam Track 1') – or it shows the label of the second layer with its real time meter next to it (see [chapter 2.7.1.1](#) for details). The last option is only available, if 'Two Layer Mode' is activated in the graphic controller.
- Indication of channel type by color coding of the lower half as well as writing the type in the bottom right corner.

The following information pops up when appropriate:

- Fader value in dB, when touched (or 'held' in dynamic automation mode)
- Graphical representation of current setting and previewed snapshot at the same time.
- Snapshot filter mode of the fader. (TRIM or ISO). A solid yellow background of the word ISO indicates that the whole channel is isolated from snapshot recalls. In case the word is written only in yellow letters with black background, this indicates that only parts of this channel are isolated from snapshot recall.
- N-1 indication and bus number.

Touching the upper half (for input channels, multi-track input channels, multi-track monitor channels): Opens the GC's General Patch window, showing the *channel input* position of the selected channel..

Touching the lower half (for all channels): Opens the GC's General Patch window, showing the *direct output* position of the selected channel.



- ⊕ VIEW: CHANNEL Brings up a view of all control elements of this channel besides dynamics, equalizer, and pan, covering the whole Vistonics® rotary control area.

- ⊕ VIEW: MISC **View Selection of DYNAMICS, EQ, and PAN Controls**
Brings up a view of selected control elements out of dynamics, equalizer, and pan, covering the whole Vistonics® rotary control area. The **VIEW CHANNEL** and **VIEW MISC** keys form a sort of 'center assign panel' function, known from many other consoles, such as the Studer D950 M2.

- ⊕ VIEW: BUS ASN Brings up the bus assign view of one channel, covering the whole touch screen area.
When showing the bus assignment of a single channel, the assignment can be changed by touching the bus number. It is also possible to clear all bus assignments of a type by pressing the corresponding key on the touch screen.

2.2 Fader Area

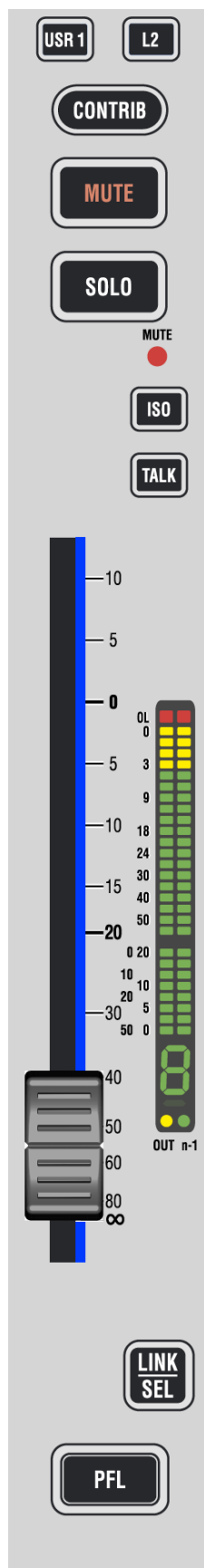

USR 1 Key for programmable user- or application-specific functions (such as fader start, fader ramps (audio-follows-video), switching to an alternate n-x output signal, user specific functions etc.).

L2 The virtual desk width may be reduced from six sections to three double sections (see [chapter 2.7.1.1](#)). The previous sections 4...6 then serve as a second (lower) layer of the console. By pressing **L2**, individual channel strips can be switched between the upper and lower layers.

CONTRIB Very often it is useful to operate the console in ‘reverse’ way coming from an output fader, and operate the various input channels contributing to this output. By pressing the **CONTRIB** key the Vistonics™ rotaries will show all channel faders currently contributing to this master signal. In case of a matrix or AUX master output, the view shows all channels contributing to this output, hence input, subgroup or master channels.

On the fader bay, this is especially useful to see the contribution from N-1 bus owner channels. But also on master channels, the contribution view can be used the same way as in the control bay.

⊕ **MUTE** Mutes the corresponding channel. The **MUTE** LED indicates when the channel is muted by a SOLO IN PLACE function or by a mute group.

⊕ **SOLO** Depending on the setting of **SOLO**, and **SOLO IN PLACE** keys, this activates the SOLO, or SOLO IN PLACE function of the corresponding channel. The solo signal is always inserted into the control room monitoring path as soon as at least one channel is active.

As a standard the SOLO works in non-additive mode. This means that pressing a second SOLO button will automatically release the first one. However, additive mode can be entered by press-and-hold at least two SOLO buttons at the same time. From then on any other SOLO is added without canceling the first ones. Non-additive mode is re-activated by canceling all active SOLOs.

⊕ **ISO** The whole channel may be filtered from snapshot recalls by pressing this key. It is also possible to isolate only certain elements of a channel, such as the EQ. This is done by pressing and holding the **ISO** key while pressing the corresponding audio key in the central ‘Channel Processing’ area. Pressing e.g. the **EQ** on/off key will put the whole EQ into ISOLATE mode. Touching a rotary encoder will put just that rotary into ISOLATE mode, indicated by a yellow ‘I’ or – if one of the Vistonics® keys is selected – just by changing its color to yellow. It is also possible to e.g. open up the EQ view on the Vistonics® screen and select only one single parameter of the EQ to go into ISOLATE. If one of the EQ parameters is isolated, but not the whole EQ, the **EQ** on/off key becomes half-lit while pressing **ISO**. If the ‘Enable Trim Mode’ option in the Static Automation Options page is active, the status of the elements doesn’t only toggle between READ and ISOLATE, but also goes to a red ‘T’ (TRIM). On Vistonics® keys this status is indicated simply by changing the button’s label color to red.

The **ISO** key is fully lit, in case the *whole* channel is currently isolated from snapshot recalls. This state is accompanied by the word ISO with solid yellow background in the Generic Display Area.

⊕ **TALK** Activates talkback to the direct output of this channel and, if applicable, to the n–1 bus output. In case this channel is participating an off-air conference at this time, talkback is activated to all members of the conference.

- ⊕ **PFL** Activates pre-fader listening mode. Signal is fed to the near-field monitoring outputs as standard, but can be inserted into the main control room monitors by pressing CR INJECT.

As a standard the PFL works in non-additive mode. This means that pressing a second PFL button will automatically release the first one. However, additive mode can be entered by press-and-hold at least two PFL buttons at the same time. From then on any other PFL is added without cancelling the first ones. Non-additive mode is re-activated by cancelling all active PFLs.

2.2.1 Channel Meters

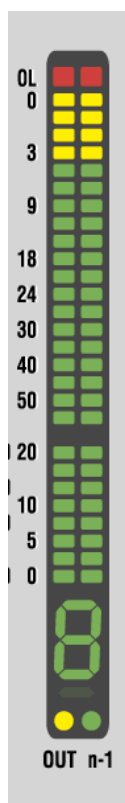

Each channel strip hosts a tri-coloured two-channel LED bargraph meter, indicating various levels of the corresponding channel. The lower part of the meter is reserved to show gain reduction in case compressor/limiter (right side) or expander/gate (left side) is active. One LED element stays on permanently if any of the dynamic processing is switched on.

The upper part is showing levels. If a mono signal is displayed, both bargraphs are linked and show the same level. A temporary peak hold helps finding current peak levels. A separate red element on the very top indicates OL, i.e. overload. The headroom of the meters (i.e., the point where they change from green to yellow) can be adjusted within $-25 \text{ dB}_{\text{FS}}$ and $-5 \text{ dB}_{\text{FS}}$ using the graphic controller screen (Option – Meter/Generator menu).

The following levels may be displayed and indicated using the two dots below the meter:

- Channel input level (post input processing): left dot dark
- Channel post-fader level: left dot green
- Channel direct output level (if patched to an output interface only): left dot yellow.

In case the channel is an ‘n–1 owner channel’, the right half of the LED bargraph may show the n–x output level. This is indicated by a green dot above the ‘n–1’ label. Since the meters cannot show two channels of a stereo channel anymore in this mode, they will show the maximum of left and right channel at this time. Therefore: Left part of meters shows ‘max of left/right channel level’, right part shows ‘max of left/right n–1 output level’.

Control Group Indicator

The 7-segment display indicates the control group to which this channel is assigned (this is a function similar to ‘VCA groups’ known from analog mixing consoles).

2.3 Channel Selection



⊕ MULTI SEL

Used to make multiple selections; acts similar as the 'Ctrl' key on a PC keyboard.

LINK ALL

Links all channels of one type together ('Super Gang') mainly for setup purposes. After LINK ALL is pressed, all LINK / SEL keys are half-lit, waiting for the channel type to be defined (for linking). Such a 'Super Gang' includes also channels which are currently not visible on the surface!

A gang is canceled by pressing any LINK / SEL key on the desk.

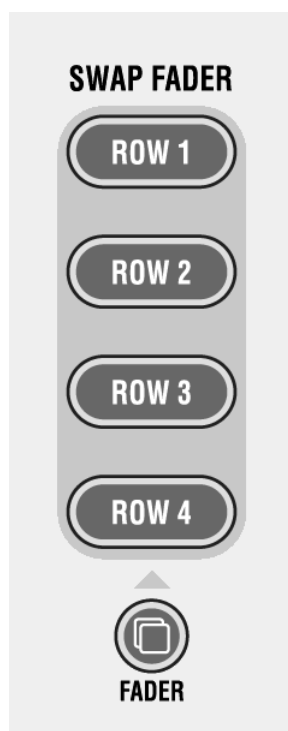

SWAP FADER: ROW 1...ROW 4

Swaps the current fader value and the MUTE key onto the selected rotary row, if the current global view on that row has a level control with the same range as the fader (-90...+10 dB), while the value of that row is temporarily displayed on the faders. The function is canceled when pressing the swap key again or when activating any other swap function.

⇨ FADER

Pressing this key will make the keys ROW 1...4 half-lit. All fader and mute values of the current gang will be copied onto the control element shown on the corresponding rotary row, if there is an appropriate parameter visible; e.g. AUX level or Direct Out Level. If the fader is copied onto a stereo AUX, the left/right pan value is also copied along with the fader and mute values.

Note: If the direct outputs of the input channels are connected to a multi-track recorder, it might be desirable to have the fader values copied over onto the direct output level controls before starting a recording. If the faders are moved, e.g. during a live transmission, the levels on the multi-track machine will remain constant.

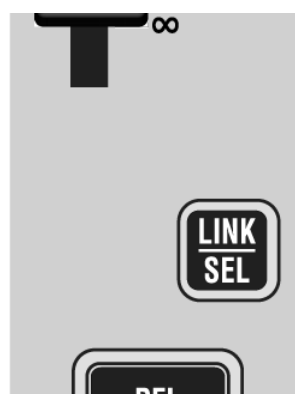

LINK / SEL

This key is used to select channels in different situations:

- Select a channel for switching audio processing such as EQ in and out.
- Select a channel for copying pasting audio values.
- Select a channel for 'channel patch view' on the GraphicController
- Select a channel for joystick assignment (PAN)
- Select/de-select a channel from a control group when in CGM setup mode
- Select a channel type when linking all channels of the same type.

Pressing two of these keys simultaneously will form a 'gang' between the two. With MULTI SEL it is also possible to select channels that are separate from each other.

All the members of a gang act together like one channel. Any change to one of the members is performed to all of them. See chapter 1.1.3 for details.

2.4 Global Views



These keys allow changing the view on the fader bays or across the whole console if FOLLOW is active on control bay. If the control bay is not in FOLLOW mode, these keys will only change the views on the two fader bays.

The different views will only cover the rotary controls that are necessary to display the corresponding function. The others will still show their previous function. However, pressing GLOBAL VIEW... a second time will blank all other rotary controls.

Example: AUX 1-4 are shown on rotary controls 1-4. The user presses GLOBAL VIEW: FILTER, and the rotary controls 1-2 will now show the input filters (rotary controls 3-4 are still showing AUX 3 and 4). When the user presses GLOBAL VIEW: FILTER again, the rotary controls 3-4 will be blanked.

- ⊕ GLOBAL VIEW: MIC CTRL
- ⊕ GLOBAL VIEW: INPUT (gain)
- ⊕ GLOBAL VIEW: OUT n-1
- ⊕ GLOBAL VIEW: FILTER
- ⊕ GLOBAL VIEW: DLY - INS
- ⊕ GLOBAL VIEW: COMP - LIM
- ⊕ GLOBAL VIEW: EXP - GATE
- ⊕ GLOBAL VIEW: EQ
- ⊕ GLOBAL VIEW: PAN
- ⊕ GLOBAL VIEW: AUX MONO ...
- ⊕ GLOBAL VIEW: AUX STEREO...

⊕ PRE / POST – AUX View Modifier

When auxiliaries are shown on the rotary controls, they have an on/off key next to the rotary control. By pressing the PRE / POST modifier key, the key next to the AUX rotary control will change its function to pre-/post-fader.

⊕ ↑ (Shift)

Changes the meaning of the GLOBAL VIEW: AUX... keys to select the upper half of auxiliaries: AUX MONO 17-32 or AUX STEREO 9-16.

Note: When pressing GLOBAL VIEW: EQ while the ↑ (Shift) key is active, there is an alternate EQ view. Then the four rotaries will show only the two mid bands, but allow access to frequency and gain setting.

Also, if Shift is active, pressing the local views ‘VIEW CHAN’ and ‘VIEW MISC’ will exclusively show all auxiliaries of the corresponding channel. Therefore it is possible to see up to 40 mono and 20 stereo auxiliaries of a channel when pressing MISC and CHANNEL on a channel strip. This is useful when working with large numbers of auxiliary and matrix buses.

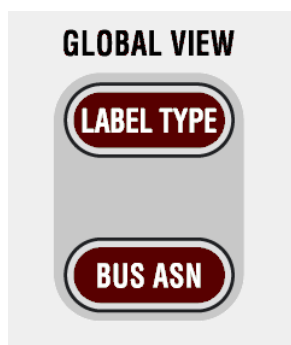

GLOBAL VIEW: LABEL TYPE

Changes the label type of the second line in the generic display area to show:

- Inherited label (also known as session label)
- Fixed label (shows the channel number)
- Inherited label of second layer (if activated)

GLOBAL VIEW: BUS ASN

Activates a 'bubble view' of the bus assignment throughout the whole console. If the bay is locked, only the corresponding bay is affected.

2.5 Central Channel Processing Keys



This set of keys is used to switch processing on/off within one or several channels. It also hosts keys to copy and paste settings between channels or between the clipboard library and channels. As a standard the user selects a channel first (pressing **LINK / SEL**) and then switches e.g. EQ On. If a gang is made, the switching will happen on all member channels of the gang. As soon as a local view change is done on another channel (e.g. touching the EQ graphic in order to open the EQ view locally on a Vistonics® screen), these set will become active for that specific channel. After closing the EQ view, the set is again dedicated to the channel(s) with **LINK / SEL** active. If several views are opened on the Vistonics® screens, the key set is following the principle of 'last wins'. Wherever a view has been opened last the 'Channel Processing' key set is active.

Example 1: The user wants to activate compressor/limiter in channel 10. In order to do that he either presses **LINK / SEL** on channel 10 first, followed by the **COMP / LIM** key on the central channel processing keys. Or he may open any local views such as touching the dynamics curve on the touch screen (therefore opening the view of the dynamics section) and then presses **COMP / LIM** on.

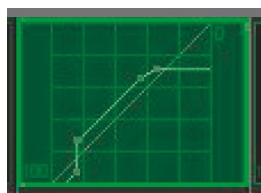

Example 2: The user wants to switch on a low cut filter on channels 1-20. The fastest way to do that will be to first create a gang of the channels 1 to 20 (press-hold **LINK / SEL** on channel 1, followed by **LINK / SEL** on channel 20). This will assign the central processing keys to the whole gang, so the user can now press **COMP / LIM** on and have it activated on all ganged channels together. Finally the user may want to delete the gang by pressing any **LINK / SEL** key.



- ⊕ HI CUT
- ⊕ LO CUT
- ⊕ DELAY
- ⊕ INS
- ⊕ COMP / LIMIT
- ⊕ EXP / GATE
- ⊕ EQ
- ⊕ PAN

Audio functions on/off; if lit, the corresponding audio function is activated. If dark, the function is bypassed. For more details about functions and their parameters refer to [chapters 3.3 and 3.4](#)).

☞ (Copy/Paste)

Dedicated to each audio function, these keys act as copy (first step) and paste (second step) at the same time. The philosophy of using the central key set for copying and pasting is the same as when switching processing on and off. First select source channel, press copy/paste of the corresponding function, then select destination channel and press the same copy/paste ☞ key again in order to paste into this channel.

After having copied the value of the source channel into the internal clipboard (first press), the source channel key is fully lit while all possible destination channels are half-lit (see this after changing LINK / SEL). This guides the user to select the destination channel efficiently. After having selected one of them as destination key (second press), the copy/paste function is terminated. Nevertheless there are several ways to paste the clipboard value to multiple channels:

- Create a gang and paste the value into one of the members
- Hold MULTI SEL before pasting to channels of your choice.

Example 1: The user wants to copy the EQ settings of channel 8 into channel 10.

- 1 Press LINK / SEL of channel 8 – or open e.g. the EQ view on channel 8 by pressing the EQ graphics on the touch screen. Alternatively any view of channel 8 could be opened, e.g. by touching the dynamics or pan graphics – or selecting CHANNEL or MISC view on that channel.
- 2 Press Copy/Paste key next to EQ, located on central CHANNEL PROCESSING keys.
- 3 Press LINK / SEL of channel 10 – or open e.g. the EQ view on channel 10 by pressing the EQ graphics on the touch screen. Alternatively any view of channel 10 could be opened, e.g. by touching the dynamics or pan graphics – or selecting CHANNEL or MISC view on that channel.
- 4 Press Copy/Paste key next to EQ, located on central CHANNEL PROCESSING keys.

Example 2: The user wants to copy a low cut filter from channel 1 into channels 11-20.

- 1 Select channel 1 by any of the ways described in example 1.
- 2 Press Copy/Paste ☞ key.
- 3 Create a gang between channels 11 and 20 by press-and-hold LINK / SEL on channel 11, then press LINK / SEL on channel 20.
- 4 Press Copy/Paste key again.
- 5 Delete the gang by pressing any LINK / SEL key.

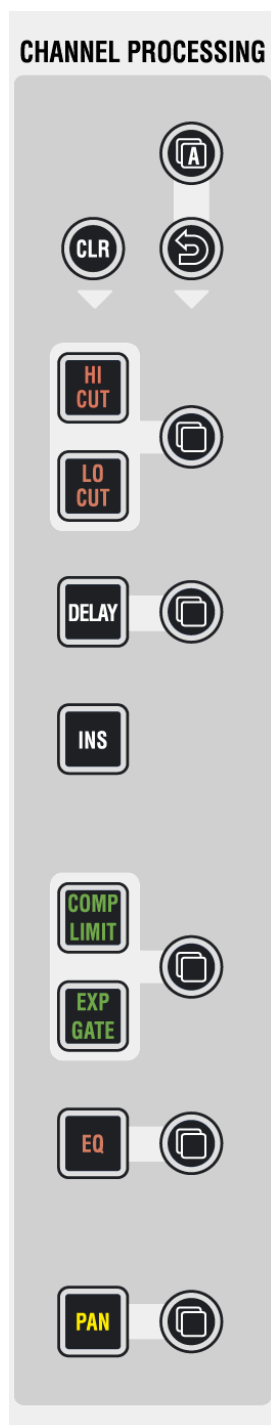

⌘ A (Copy/Paste All)

As ⌘ above, but includes *all* functions of a channel at the same time. This includes input gains, AUX, fader and bus assign. This function ‘clones’ the whole channel.

Hint for console setup: Set one channel to the desired status, including bus assignment etc., create a ‘super gang’ by linking all input channels together, and press ⌘ A (Copy/Paste All) twice. This will bring all linked channels into the same status.

⌘ (Undo/Redo)

After having copied a setting into one channel, this key will reverse the last paste function. If a clear function has been performed, this key will reverse the last clear function. Note that ⌘ (Undo/Redo) remembers each channel’s settings. It is therefore possible to undo a function on several channels by applying ⌘ (Undo/Redo) on a gang.

There is also a shortcut for comparing settings within one channel:

- Press copy/paste in one channel twice (this copies the current value into the clipboard and pastes it back into the channel).
- Now change to an alternate value.
- When pressing ⌘ Undo/Redo, the user can toggle between the two settings and compare by listening.

Note: By using the temporary function of this key, it is possible to compare the two settings with a single key press!

CLR

After having pressed this key once, all possible destination keys (audio on/off keys) are half-lit. Pressing one of them will reset its value to the default value. Selecting the ⌘ A (copy/paste all) key as the choice to clear will reset all parameters within this channel, including bus assignment. It is also possible to use the MULTI SEL key ([chapter 2.3](#)) to clear multiple functions. In order to set the fader of the channel to 0 dB, it is possible to touch the fader after having pressed CLR. After releasing the fader, it will set to 0 dB.

CLR can also be applied to a whole gang.

2.6 Control Bay Details

2.6.1 System/TB/Headphones



STBY Indicates that AC power is connected to the desk. Flashes, if redundant power supplies are fitted and power is lost on one of them.

MAIN ON Indicates that the power for the control system is ok. Pressing **ON** will switch the system on. For switching the system off, normally the Shutdown command in the Vista application is used. Pressing **ON** for several seconds will activate an emergency shutdown.

DESK ON Indicates that the desk is switched on. (For service purposes, it may be necessary to power off the desk part only, while the control PC remains on. This can be accomplished by pressing this key for several seconds. Another short press will power on the desk again. A warning message will be displayed and the GC will be re-started. Powering off the desk also powers off the monitoring outputs.)

DATA USB port for plugging any USB compliant USB device, such as a memory stick, in order to backup data of the console. It is possible to backup individual productions from within the Vista application software – or make backup an image of the whole system using the installed special software. See chapter 4.6.1 for more details about how to make image backups and how to restore them onto a console.

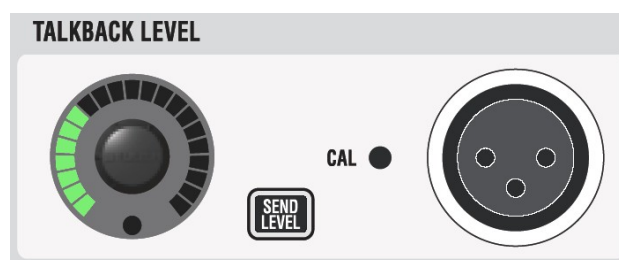

TALKBACK (Return) LEVEL Level setting for talkback signal coming into desk using ‘TB IN’ connectors on the rear of desk. Signal is fed into the near-field speakers.

SEND LEVEL If the **SEND LEVEL** key is active, the **TALKBACK LEVEL** knob adjusts the input sensitivity of the internal talkback microphone instead of the TB return level. This level setting is realized in the digital domain and therefore post-analog limiting.

HEADPHONES

Adjusts level of headphones. The headphone signal is the same as the one listened to in the control room. However, whenever a PFL is active, the signal gets fed into the headphone with higher priority.



2.6.2 Loudness Metering

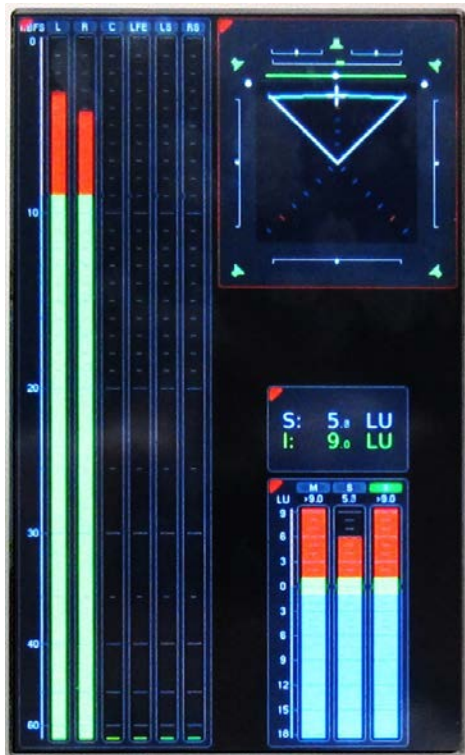

Evaluating program loudness is a very hot topic in today's radio and TV production and broadcasting. By integrating loudness metering as standard, Studer now has a solution that provides instant loudness monitoring by integrating suitable metering directly into the console.

In collaboration with RTW Germany (www.rtw.de), a custom RTW TM7 TouchMonitor unit was added to the Vista 5 digital console. This meter is internally connected to the desk monitoring. A total of eight signals are internally wired to the meter: DirOut of CR Monitoring (6 channels), as well as PFL L and PFL R. These signals are available to the TM7.

The TM7 version manufactured for Studer features several different presets, such as loudness metering according to ITU (BS1770 and BS1771), ATSC (A/85) and EBU (R128) recommendations in both stereo and surround. PPM bargraph meters with several different international scales, moving-coil instrument emulation and audio vectorscope display are included as well.

A USB interface for connecting a memory device is provided on the TM7 unit inside the desk. It allows licence and preset handling.

Operation For TM7 TouchMonitor operation, please refer to the PDF document contained on the product data DVD shipped with the console.

2.6.3 Control Room Monitoring



MONO, L-R, LCRS, 5.1 Selects the control room monitoring format. The monitoring section hosts a 5.1-to-two-channel downmixer. When **L-R** is active and the selected monitoring source delivers a 5.1 signal, the six channels get downmixed automatically to two channels. The way this downmix is done can be set in a dialog box on the graphic controller screen. This screen becomes visible by pressing the **SETUP** button.

The **MONO** setting will sum the left and right monitor speaker signals.

⊕ **Ø**, ⊕ **X** Phase inversion on left channel, and left/right channel swap for mono or two-channel stereo mode.

⊕ **INS DEC** Inserts the encoder/decoder chain into the monitoring path. Inputs/Outputs can be found on the rear of the desk. This function needs to be activated in a .ini file on the system at installation time. *Edits may only be done by educated Studer service personnel.*

⊕ **METER MON** Makes the monitor meters indicate the monitored signal instead of the pre-assigned signals.

⊕ **L**, ⊕ **C**, ⊕ **R**, ⊕ **LS**, ⊕ **RS**, ⊕ **LFE** These keys act as solo or mute keys for each speaker being currently active, depending on the monitoring format selection. The mode is pre-selected by the **SOLO** and **MUTE** keys on the right. It is also possible to clear all pressed keys with the circular **CLR** key next to **MUTE**.

SOLO, SOLO IN PLACE These keys define the mode the console is in when pressing **SOLO** on a channel strip. It can be either **SOLO** (post-fader listening incl. pan), or **SOLO IN PLACE** (solo by muting all channels but the selected one, masters and other defined channels; destructive mode). Pressing **SOLO** for several seconds allows adjusting the solo offset level applied in the monitoring whenever a

solo is active. The offset level is displayed where normally the listening level of the control room is visible. Turn the CR level knob for adjustment of solo offset level.

- CLR** If any of the **PLF** or **SOLO** keys on the console is active (even if it is currently not visible on the surface), this key will be lit. Pressing it clears all activated **PLF/SOLO** functions on the channels.
- EXT PFL SPEAKER** This rotary control adjusts the level of the PFL signal going to the near-field speakers. The near-field speakers are also used for listening to talkback return signals.
- PFL TRIM** Pressing this key allows adjusting the solo offset level applied in the monitoring, whenever PFL is active. The offset level is displayed in place of the control room level. Turn the CR level knob for solo offset level adjustment.
- LIVE** If active: Disables some dangerous functions for live work, such as talkback to masters, and solo in place. It is possible to use this key to arm the cuelist, so that the **NEXT** and **PREV** keys are activated on the desk. See static automation settings in chapters 4.4.4 and 4.4.4.5.
- PFL BC** Activates a mode where PFL or SOLO on a channel is automatically canceled whenever the channel fader is open. A setting in the 'Vista Desk Settings' menu allows activating the function where the PFL/SOLO comes back after the fader has been closed again.
- CR INJECT** If active: PFL signals will be audible in the main control room speakers as soon as any **PFL** function is activated. Channels with **SOLO** active are always inserted into the control room.
- SIP SAFE** Pressing this key enters setup mode for editing the channels that should be safe from muting when activating **SOLO IN PLACE** on any other channel; by default, all master channels are safe from muting when **SOLO IN PLACE** is active. It may be desirable to protect effect returns from muting by adding them to the group of safe channels. When in **SIP SAFE** setup mode, it is possible to select or de-select individual channels on the desk by pressing their **LINK / SEL** key. Pressing **SIP SAFE** again will cancel edit mode and activate the selected SIP protection. The information on the channels to be protected is saved in each title, and therefore may vary from title to title.
- Note:** As a standard, the **MULTISEL** key is active when entering **SIP SAFE** setup mode. In this way it is possible to select or de-select any channels to be safe from muting. However, for clearing *all* currently selected and safe channels (including master channels), the **MULTISEL** key may be de-activated. When pressing any **LINK / SEL** key of a channel, all others will be de-selected.
- ⊕ **NEAR FIELD**, ⊕ **MAIN** Selection of two speaker sets: **MAIN** is multi-channel surround (5.1), **NEAR FIELD** is a two-channel stereo system. A separate level control is available for each set of speakers, but can be deactivated at installation time. This may be done in the monitoring.ini file by experts only.

The near-field speakers are also used as PFL speakers as well as for monitoring off-air conference between external participants. The priority to what signal is audible is set as follows:

1. PFL (unless CR INJECT active)
2. Nearfield
3. Off-air conference.

The level may be set differently for each of these cases. EXT PFL level may adjust the off-air conference monitor level as soon as this signal is monitored.

⊕ MUTE, ⊕ DIM, ⊕ dB SPL

For muting, dimming, and setting the level of the control room speakers. DIM level may be adjusted by pressing this button several seconds. The corresponding DIM level is displayed in the control room level display. Adjust the DIM level with the control room level knob.

Note: The level calibration of the different speakers as well as trimming the individual speakers is done using the graphic controller screen.

2.6.4 Studio Monitoring

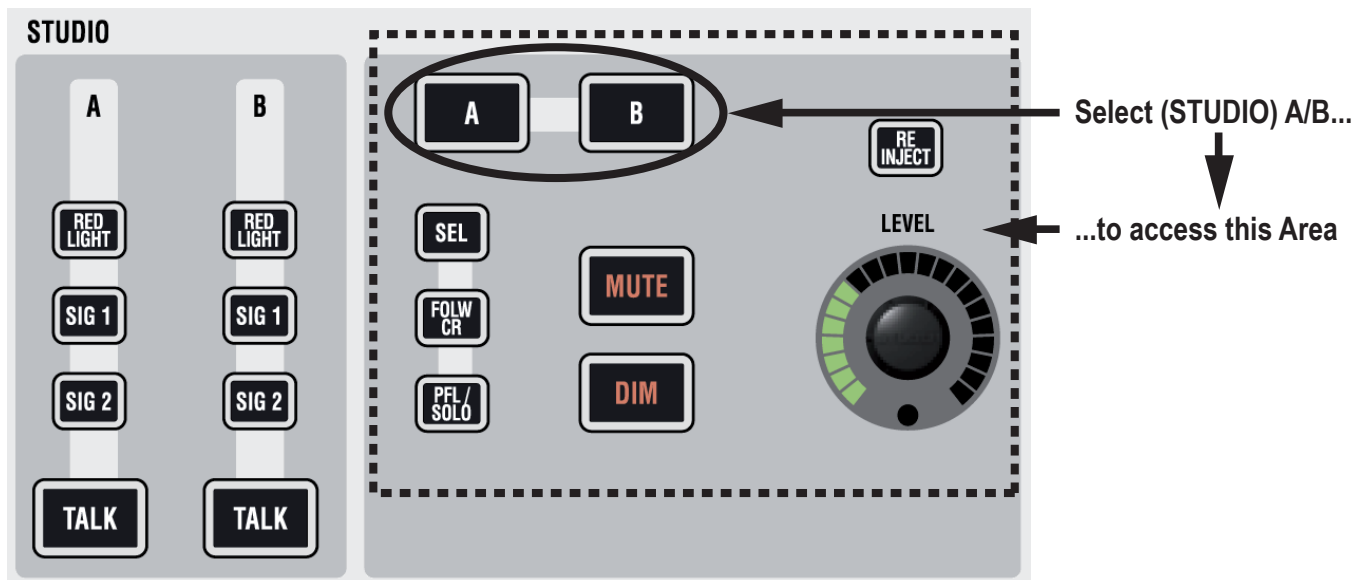

Vista 5 BE gives direct access to the most important functions for two studios. Control and view of the following functions are directly accessible, without having to select the appropriate studio first:

A / B RED LIGHT, SIG 1 (Ready), SIG 2 (Call), TALK

These keys allow activation of the corresponding function; they may light automatically if the function has been activated e.g. by one of the GPI (general purpose inputs).

The right part of the studio monitoring panel is used to control the audio level of the two studios. First select the studio (A or B), then adjust the level and select from ‘Selected Source on Source Selectors’ (SEL), feed studio with same source as control room (FOLW CR), or send PFL/SOLO signals to the studio (PFL/SOLO). It is also possible to disengage the mute mechanism normally activated by the red-light logic. This is done by activating RE-INJECT.

2.6.5 Monitoring Source Selection

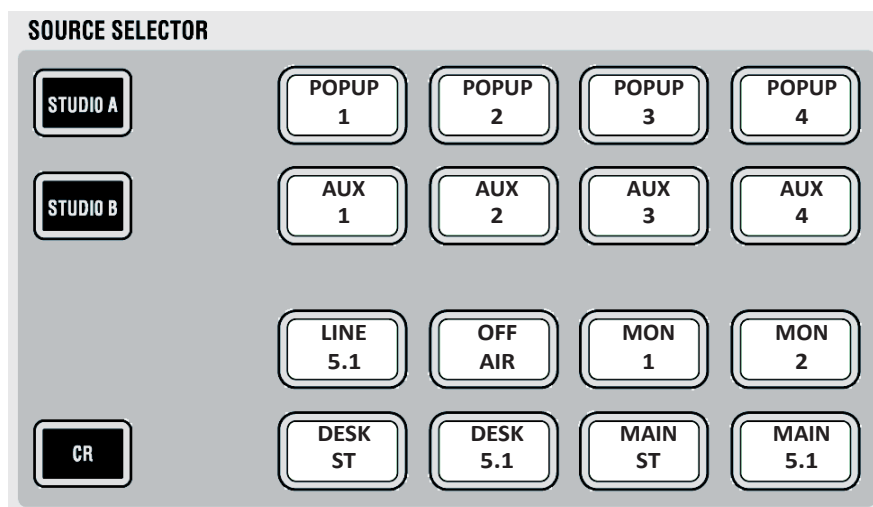

First select the target to be changed: CR (control room), STUDIO A, or STUDIO B. Then select the appropriate source key. All keys are fully user-definable by using the monitoring setup dialog on the control screen (accessible to system administrators only). Each key may independently feed a set of one to six loudspeakers. It is therefore possible to have a two-channel stereo source on one key, while another key selects a 5.1 surround source.

Note: For the control room, it is possible to activate the **SOURCE SELECTOR** top row to be 'sub-selectors' rather than selectors, allowing 12 sources to be assigned to each of these keys. This functionality makes 48 sources available for listening in the control room, rather than the standard 16. Activation is done by editing the monitoring.ini file. *This may be done by experts only.* Pressing one of the 'sub-selectors' will make one of the 12 sub-sources selected and audible in the monitoring. Pressing the sub-selector again will open up a list of all 12 sources available for this sub-selector on the Graphic Controller screen. Select any of the 12 with the trackball, then close the dialog by pressing the same sub-selector key again. If none of the 12 sources is selected, the dialog will pop up automatically upon the first key press in order to make a selection with the trackball.

2.6.6 Option (Spare Keys)

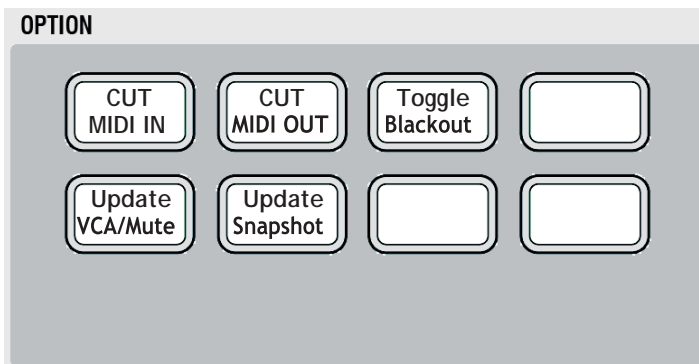

This area contains spare keys for future functions and/or options. Key #3 is currently used to switch on the desk lights again after a 'blackout' event within the theatre cue list.

2.6.7 Custom Panel Keys

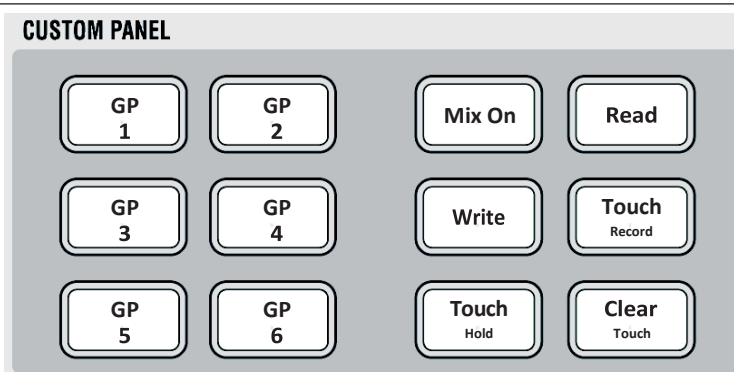

The block of six keys on the left-hand side is controlling the GPIO's which are wired to the d-type connector on the rear of the console. The six keys on the right-hand side are used by the Vista application SW; they are currently operating the six most important buttons of the ACU (automation control unit - used in dynamic automation mode).

2.6.8 Talkback Control

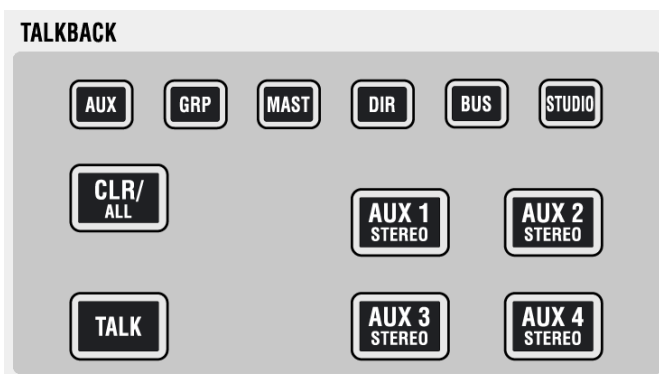

- ⊕ **TALKBACK** Whenever **TALK** is pressed, the signal from the internal talkback microphone is fed to the corresponding group.
Note: The talkback signal is inserted directly before the output interface of the core. If signals are routed internally to some other destinations, the talkback

Available talkback destinations:

- **AUX:** direct outputs of all AUX masters
- **GRP:** direct outputs of all group masters
- **MAST:** direct outputs of all masters
- **DIR:** direct outputs of all input channels
- **BUS:** outputs of all multi-track buses (without faders in between)
- **STUDIO** (talkback to both Studio A and B simultaneously).

🕒 **AUX 1...4 STEREO** For talking to headphone mixes, these keys can be used to directly activate talkback to the corresponding AUX master outputs.

Talkback and Signaling Block Diagram **VISTA 5 BLACK EDITION** DIGITAL MIXING SYSTEM Using D21m GPIO Cards

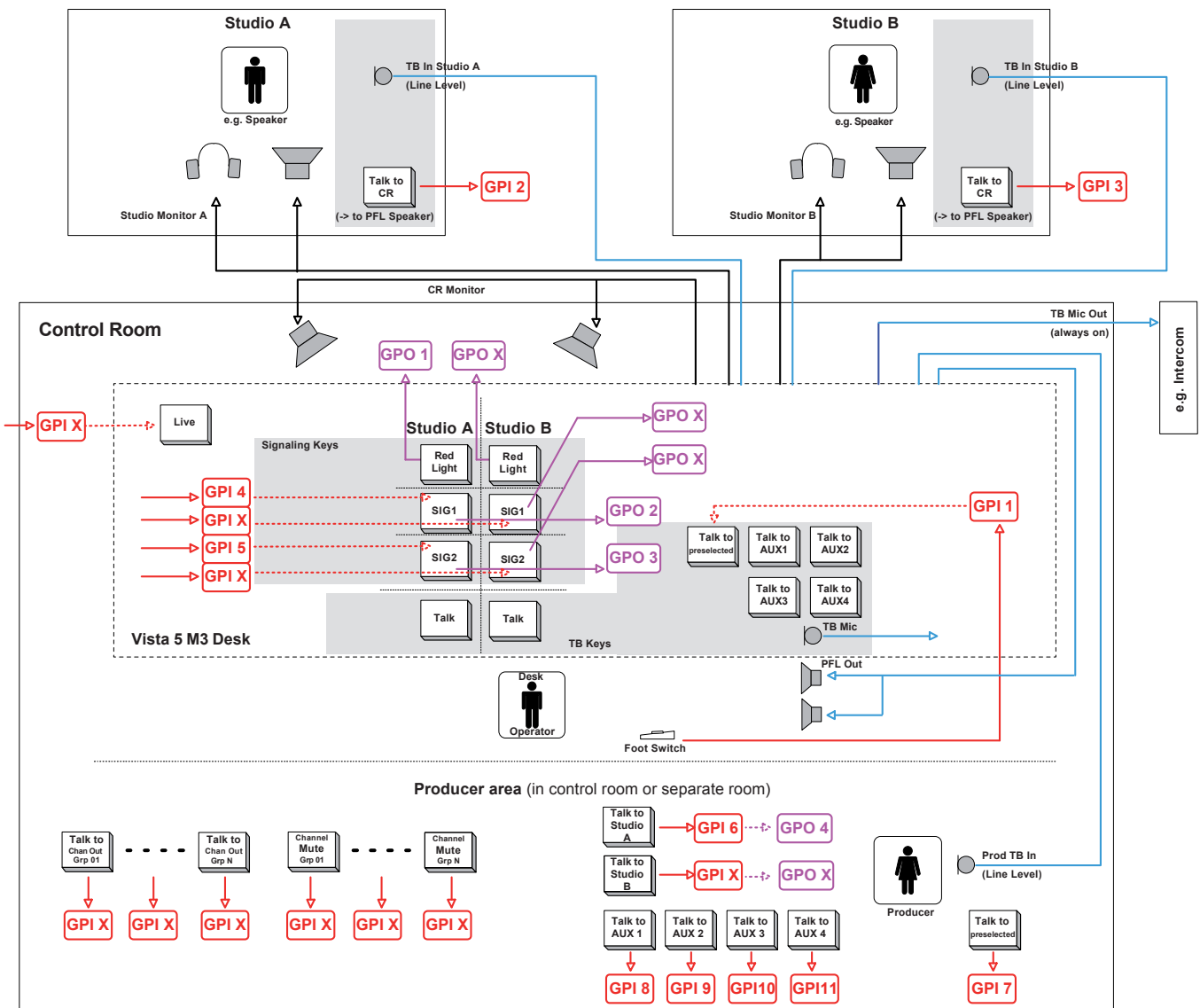

Legend:

- GPI 1** = GPI already configured in .ini files
- GPI X** = GPI prepared to use, but not assigned to signaling card. Can be configured in .ini files
- GPO 2** = GPO already configured in .ini files
- GPO X** = GPO prepared to use, but not assigned to signaling card. Can be configured in .ini files

Already configured:

- GPI 1 Footswitch to talk to preselected
- GPI 2 Talk to CR from Studio A
- GPI 3 Talk to CR from Studio B
- GPI 4 Signaling 1 Studio A
- GPI 5 Signaling 2 Studio A
- GPI 6 Talk to Studio A
- GPI 7 Talk to preselected
- GPI 8 Talk to AUX s 1
- GPI 9 Talk to AUX s 2
- GPI 10 Talk to AUX s 3
- GPI 11 Talk to AUX s 4
- GPO 1 Red light Studio A
- GPO 2 Signaling 1 Studio A
- GPO 3 Signaling 2 Studio A
- GPO 4 Talk to Studio A

2.6.9 Control and Mute Groups

2.6.9.1 Control Group Setup

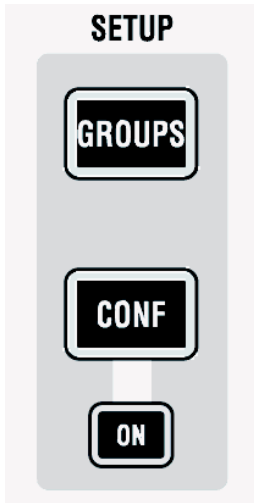

SETUP: GROUPS

Pressing this key will enter/exit control group *and* mute group mode.

After having entered **SETUP: GROUPS**, the user selects the control group he wants to edit by pressing **LINK / SEL** on the corresponding control group master channel. Then the desired channels are added to or removed from the control group by pressing their **LINK / SEL** key. The 7-segment display next to the channel fader indicates the control group number.

The control group assignment is saved within each snapshot, therefore the assignment may change from snapshot to snapshot.

*The **MULTISEL** key is active as standard, thus allowing to select and de-select individual channels. Clearing the entire definition of a control group is easily done by pressing the **MULTI SEL** key, so that it gets dark. After that, any press on **LINK / SEL** of any channel will clear all others. It is also possible to add multiple channels to a control group: Press and hold one **LINK / SEL** key and press another one on a different channel. All channels in between will be added to the control group.*

2.6.9.2 Mute Groups

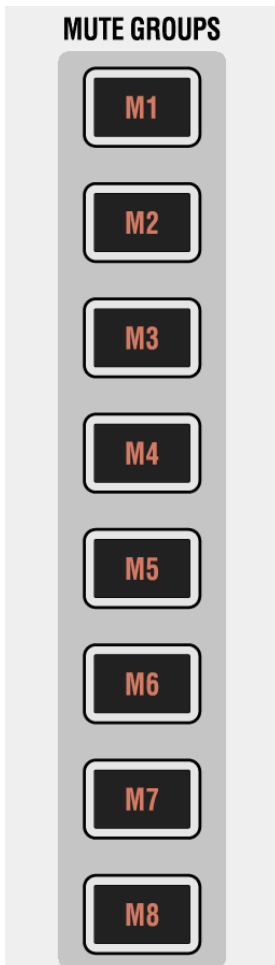

Vista 5 BE provides up to 16 mute groups. **MUTE GROUPS M1...M8** have dedicated keys on the left side of the control bay.

Mute groups **M9...M16** may be operated using eight of the 16 monitoring source selectors. Use of these keys (monitoring source selectors *or* mute groups) is defined in the 'Option: Vista Settings' menu, as shown below.

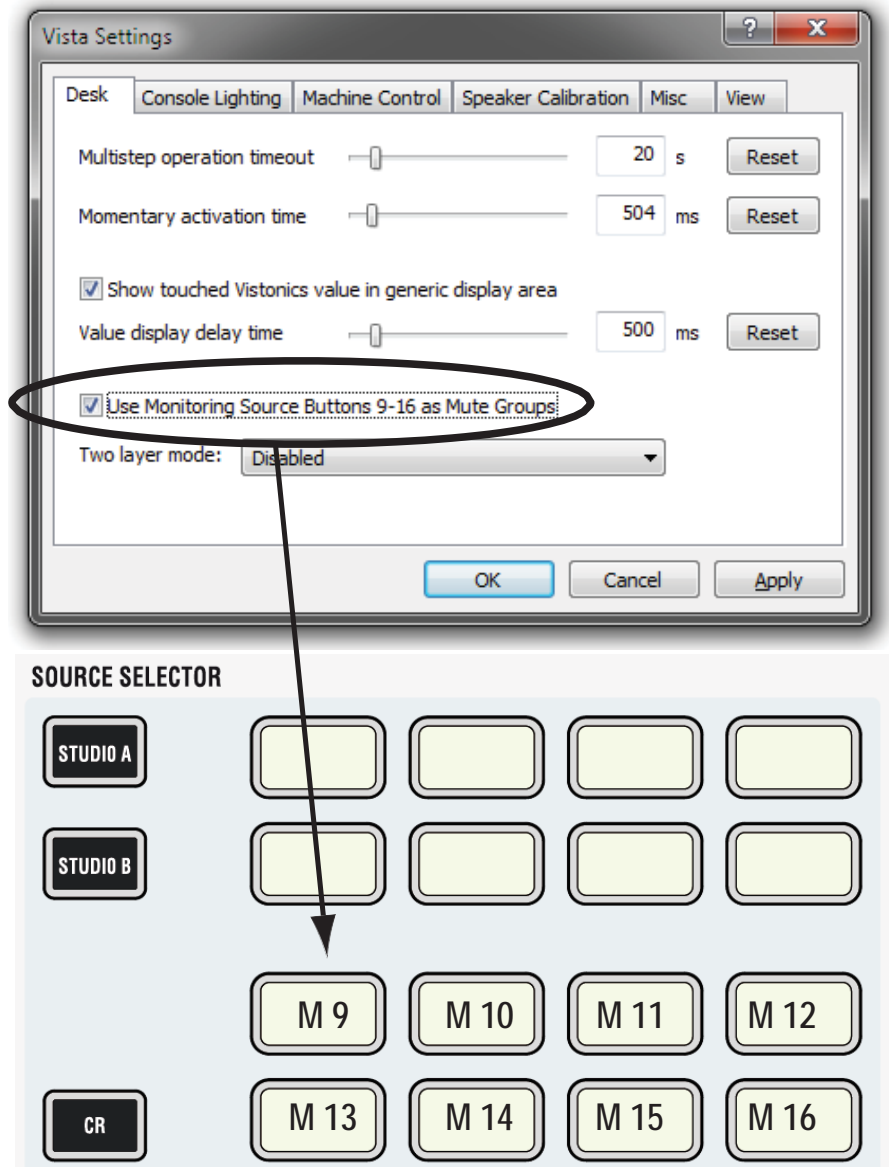

2.6.9.3 Mute Group Setup

Press the **SETUP: GROUPS** key on the control bay. The mute group master keys (dedicated **MUTE GROUPS M1...M8** keys, and, if defined, keys **M9...M16** in the **SOURCE SELECTOR** area, see above) will be half-lit.

Select the mute group you want to setup.

A dialog will pop up on the graphic controller screen, allowing you either to add all currently muted channels on the console to this mute group with one trackball click, or to clear all members from the selected mute group. You may also select or deselect members using their **LINK / SEL** key.

Press the mute group master key again in order to select another one. Please note that hierarchies can be built up as well. In other words, a mute group may contain individual channels as well as another mute group master. Hierarchies are not indicated on the desk once the set-up menu is quit. The area below the channel labels indicates whether a channel is a member of one or multiple mute groups.

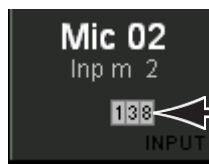

This Channel is Part of Mute Groups 1, 3, and 8

Press **SETUP GROUPS** again in order to leave the setup mode.

Assignment of channels to mute groups are saved within a so-called 'start snapshot' of each title. I.e., this information is saved once per title when the title is closed.

2.6.9.4 Off-Air Conference

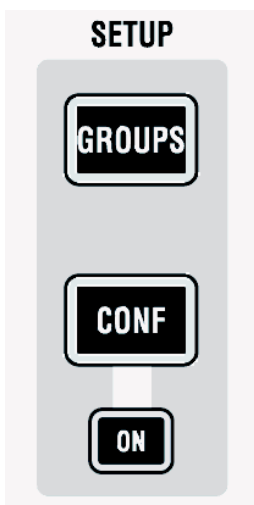

CONF: SETUP

If the DSP configuration contains n-x buses, it is possible to setup an off-air conference between n-x owner channels. After pressing this key, all n-x owner channels become half-lit and members of a conference can be selected (full-lit). As soon as their fader is closed, they will be able to talk to each other. The conference setup is immediately edited, also while the console is still in the setup mode. This allows for frequent changes of the conference members, e.g. during election reports. Talking to a member of the conference will activate talkback to the whole conference at the same time.

SETUP: CONF ON

The ON key is lit as soon as a conference is set up. The conferencing may temporarily be deactivated by clicking on the conference icon  in the toolbar or by pressing **CONF ON** on the control bay. In this case the conference definition is retained. As soon as the conference is reactivated globally (by pressing **CONF ON** or clicking on the conference icon in the toolbar again), the previously selected channels may talk to each other again.



Grayed out
Colored
Colored, crossed out

The conference icon in the toolbar has three states:

No conference active nor defined

Conference active (if member faders closed)

Conference defined, but temporarily deactivated (even if member faders closed).

Note: In certain circumstances, also an AUX master can be selected as a conference member (indicated by its half-lit **LINK / SEL** key). This is intended for adding e.g. an on-air signal to the conference. See details below. For more information refer to [chapter 4.9.7](#).

2.6.10 GC Shortcut Keys

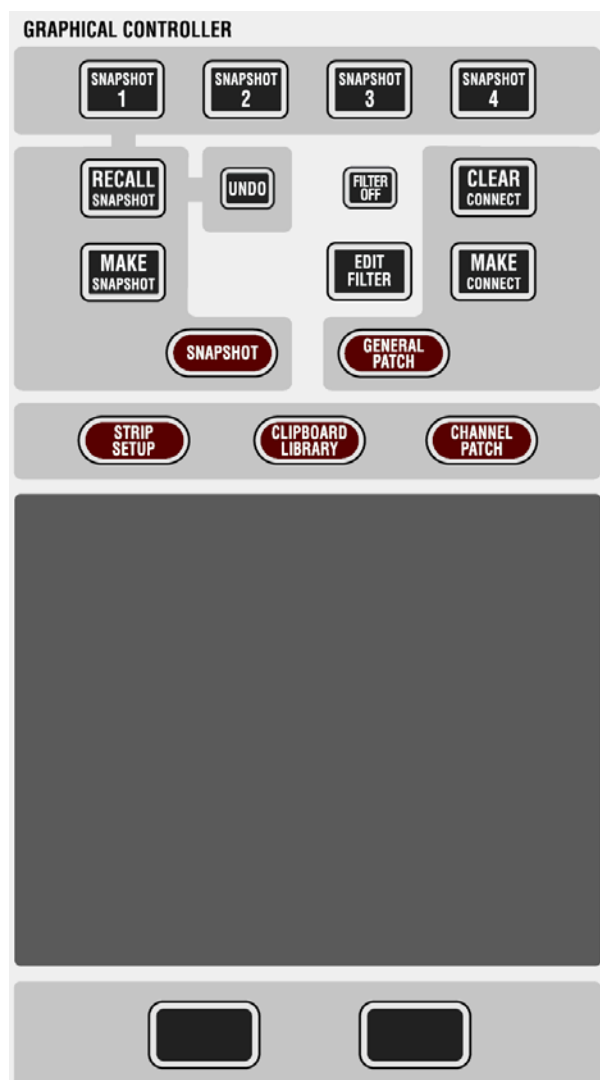
**SNAPSHOT 1...4**

A snapshot contains all audio settings including patching and labels.

These keys allow four snapshots to be saved and recalled without making use of the Graphic Controller screen.

- *Making a snapshot:*

Press and hold **MAKE SNAPSHOT**, then press one of the **SNAPSHOT 1...4** keys. This will program this key with the current audio settings.

- *Recalling a snapshot that has been programmed on one of the SNAPSHOT 1...4 keys:*

Press and hold **RECALL SNAPSHOT** while pressing one of the **SNAPSHOT 1...4** keys. This will recall the snapshot instantly, if warning mode is not active (see description of the 'Options' menu on the Graphic Controller.)

- *Preview of a snapshot that has been programmed on one of the SNAPSHOT 1...4 keys:*

Pressing one of the four keys will activate a preview of that specific snapshot and illuminate it. Values in the previewed snapshot that are different from the current console settings will be visible on the Vistonic[®] modules using *magenta-colored* indicators. ⌚ This preview function can also be activated momentarily or latching.

MAKE / RECALL SNAPSHOT

Pressing and releasing **MAKE SNAPSHOT** will create a snapshot with an automatically generated name, listed in the Graphic Controller. Filtering may be applied upon recall of the snapshot. See shortcut keys ([chapter 4.4.4.5](#)).

MAKE / CLEAR CONNECT

If the general patch window is opened on the Graphic Controller, these keys will make or clear a patch connection at the intersection of the red lines.

FILTER OFF This key switches all currently active snapshot filters temporarily off. After de-activation the filter settings are back and they need not be re-defined.

EDIT FILTER, STRIP SETUP, SNAPSHOT, CLIPBOARD LIBRARY, GENERAL PATCH, CHANNEL PATCH

These shortcut keys will open the corresponding windows on the Graphic Controller.

2.6.11 Hardware Keys



These keys give direct access to the cue list on the control bay. They can be used to control various functions of the cue list and allow certain functions to be switched using a hardware key, while it remains possible to use the trackball and operate these functions on the graphic controller screen:

- Switching on/off the cross-fade function between cues
- Activate or inactivate the cue preview mode
- Go to the next or previous cue.

Note: To prevent accidental use, the **PREV** and **NEXT** keys are only active if 'Arm Cuelist' is switched on in the graphic controller screen. The corresponding keys PREV and NEXT on the screen, however, are always active.

| | | | | | |
|----|-------------------------------|----------|-----|------|------|
| 7 | Listen to your daddy | | 2.0 | MUTE | Mask |
| 8 | Cant anybody make Crown stop | | 2.0 | MUTE | Mask |
| 9 | You done bring trouble enough | | 2.0 | MUTE | Mask |
| 10 | Where is brudder Robins | Act1 Sc2 | 2.0 | MUTE | Mask |
| 11 | Come on Sister | | 2.0 | MUTE | Mask |
| 12 | Gown got plenty | | 2.0 | MUTE | Mask |
| 13 | Overflow | | 2.0 | MUTE | Mask |
| 14 | My mans gone | | 2.0 | MUTE | Mask |
| 15 | How de saucer stan now | | 2.0 | MUTE | Mask |

Events: Library, MIDI, Notes, Timer

Configuration:

ARM CUELIST **XFade Active**

I works all de week

Summertime 2

Listen to your daddy

PREV **NEXT**

Cue and Snapshot: Make, Undo, Update

2.6.12 Joystick

**Display**

Indicates the inherited label of the channel currently assigned to the Joystick.

⇅ **Y axis lock**↔ **X axis lock**

Lock the Y axis (⇅) or X axis (↔) when moving the joystick. Pressing ⇅ and ↔ simultaneously deactivates the joystick completely and clears the assignment to a channel.

FOLLOW

Activates the joystick to display the currently selected channel (select with LINK/SEL). If a gang is present, the joystick will influence the whole gang. FOLLOW can be deactivated by a second press; the joystick will then stay assigned to the current channel.

DEFINE FOLW When a gang is active and the joystick is set to **FOLLOW** mode, the joystick will physically move to the average of all the pan values of the gang, allowing the user to make slight adjustments very quickly. However, if the user wants to do a ‘full’ pan, so that all channels will be e.g. fully left, he needs to define the channel for the joystick to display. The joystick will then move to the pan position of the defined channel, but will still keep influencing the whole gang.

Example: One dialog microphone is moving together with the ambience channels. The gang will include all channels even if the joystick is defined to show the dialog microphone by using **DEFINE FOLW**.

Operation: Create a gang, have **FOLLOW** on. Press **DEFINE FOLW** and select one of the gang members (use the half-lit **LINK / SEL** keys as guides).

2.6.13 Fader Page Navigator



These keys allow changing of the Control Bay faders to different pages. Each page may be scrolled to the left or right, allowing for a total of 120 channels to be displayed in the control bay. Any channel type may be placed on the Control Bay channel strips, including masters and input channels. Which channels are displayed on which page can be configured in the graphic controller screen using the strip setup window, second page (Control Bay tab).

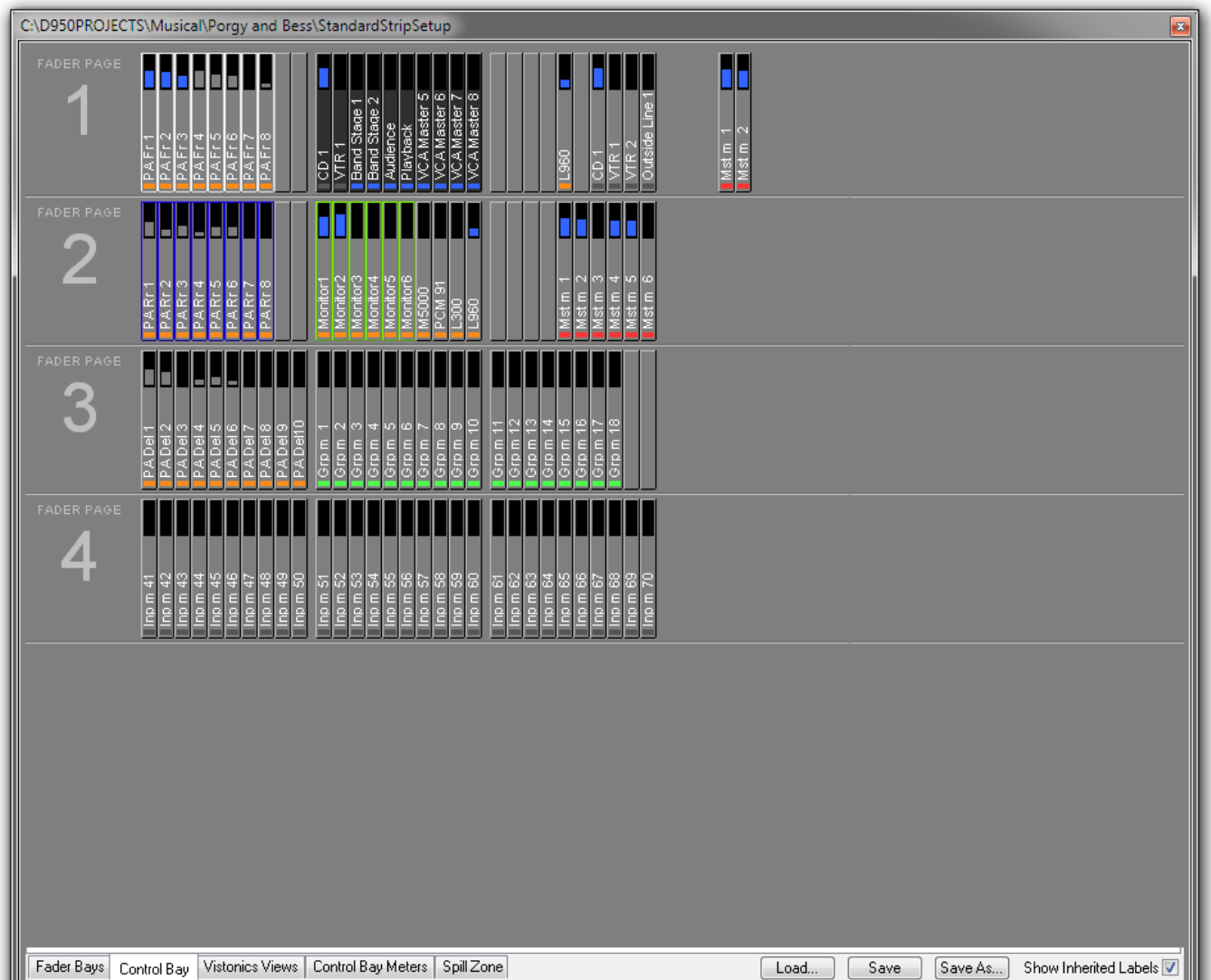

2.6.14 Grand Master Faders

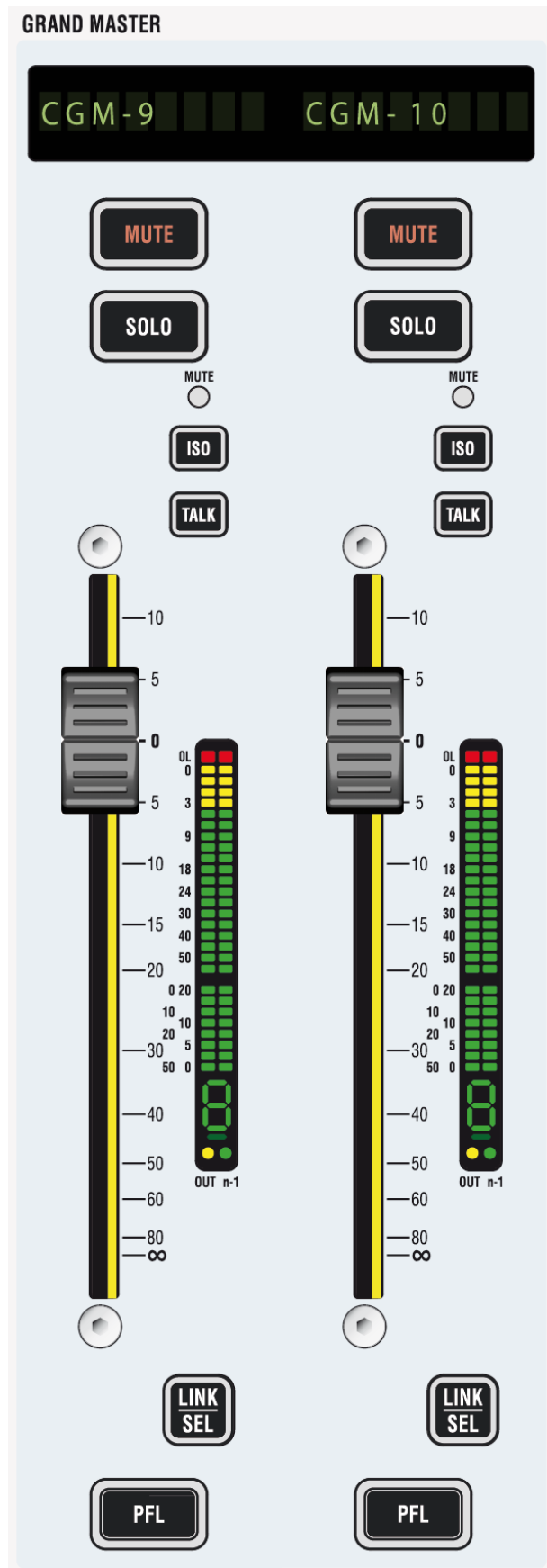

control bay also hosts two ‘grand master’ faders. The user determines which two faders are most important for him and to which he wants constant access. This may be very useful as an ‘emergency access’ to very important output faders, since these faders will never scroll or be switched over in any way. Which two channels are controlled by these faders is defined in the top right corner of page 2 (Control Bay tab) of the strip setup window, as shown above.

Note: Any two console faders can be assigned as ‘grand master’ faders, regardless of their channel type.

2.6.15 Output Views / FOLLOW



Besides the monitoring and housekeeping functions the control bay hosts twelve faders and a Vistonics® screen. The faders are independent from the rest of the console in terms of changing fader pages.

Unless the FOLLOW view is active, the Vistonics® screen is used as a collection of 40 level controls, usually representing a duplicate view of the fader bays' channel faders. The Vistonics® controls will then not only give access to the channel faders and graphically indicate their settings, but is also indicate a real-time level meter on the screen right next to the corresponding rotary control. This allows viewing up to 40 meters at a glance while having direct access to all of their corresponding faders by using the rotary control next to it. Tweaking any of the console's output levels is therefore extremely easy and fast.



The VIEW keys on the right-hand side of the control bay allow access to some predefined channel types (AUX, GROUPS, MASTERS, DIRECT OUT, BUS OUT, n-1) as well as to five user-definable views. By using the third page (**Vistonics® Views** tab) of the strip setup window (next page), it is possible to define the five user setups in a way very similar to the known strip setup window. In order to make a user view, simply select the Vistonics® elements on the screen and fill them up using the right trackball button (as shown in the screenshot in chapter 2.6.12). Although primarily intended for outputs, also input faders can be visible and controlled with these USER views.



The top user-definable view is labeled **MATRIX**. This page is also fully user-definable and covers the same functionality as the other four USER1...4 keys. As a standard the user may want to use the **MATRIX** key to see the console's matrix outputs (see chapter 4.9.5).

The function of the Vistonics® keys next to each rotary knob on the Vistonics® screen may be modified by pressing the **TALK** or **MUTE** keys. They will change the Vistonics® key from a **SOLO/PFL/SIP** key (depending on the current mode) to a **TALK** or **MUTE** key.

Note: These functions may not be available on certain channel types.

Apart from displaying meters and set levels, the Vistonics® screen also indicates the label of the displayed channel with the color coding applied accordingly.

⊕ Temporary activation of these keys is possible.

The ↑ (shift) key is reserved for future use and doesn't offer any function currently.

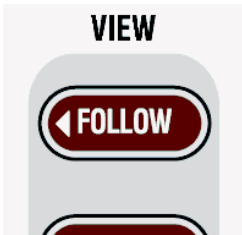

FOLLOW If this key is active, the view on the control bay Vistonics® will follow the GLOBAL VIEW of the fader bay, indicating the same 4 parameters per channel strip belonging to each of the 10 faders below. This mode makes the control bay become a fully functional fader bay, it may be used to operate input channels.

2.6.16 Contribution Access



Very often it is useful to operate the console in ‘reverse’ way, coming from an *output* fader and operate the various *input* channels contributing to this output. By pressing the CONTRIB key on top of a fader the Vistonics® rotaries will show all channel faders currently contributing to this master signal. In case of a matrix or AUX master output, the view shows all channels contributing to this output, hence input, subgroup or master channels.

‘Contribution’ can be operated in two ways, depending on the state of the REDUCED (View) ON key on the left-hand side:

REDUCED (View) ON When pressing CONTRIB only the channels currently assigned to the corresponding master bus are displayed.



REDUCED (View) OFF All channels that *may* contribute are displayed. These are all channels that can be assigned to that specific output bus. This view allows assigning or de-assigning them from the master bus by using the corresponding Vistonics® keys.

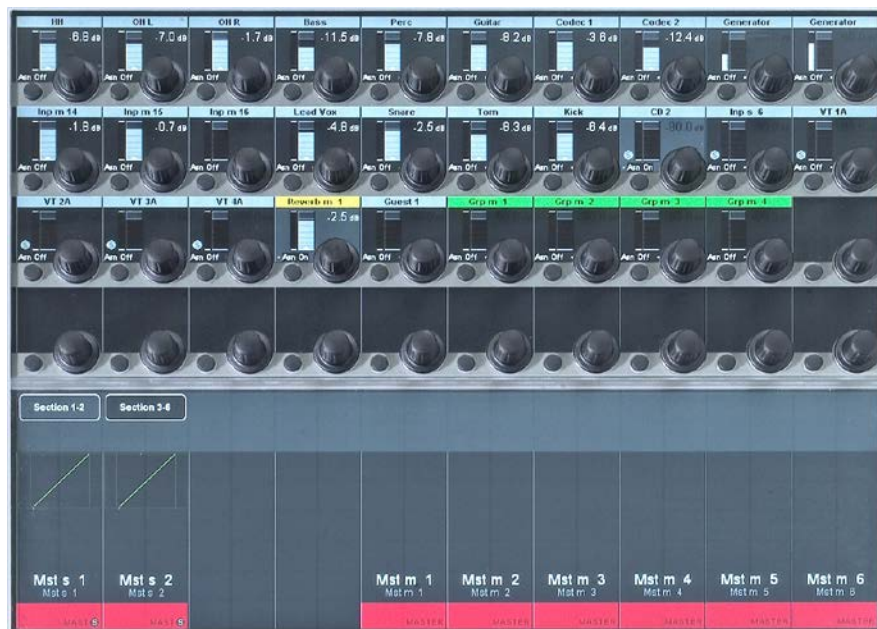

It is extremely easy to adjust a balance of e.g. a matrix output without accessing the fader strips of the contributing channels.

When working in **REDUCED (View) OFF** mode, another advantage becomes apparent: The operator may do the bus assign now by choosing the output first and then assign the corresponding channels to it.

2.7 Fader Bay Details

2.7.1 Channel Control

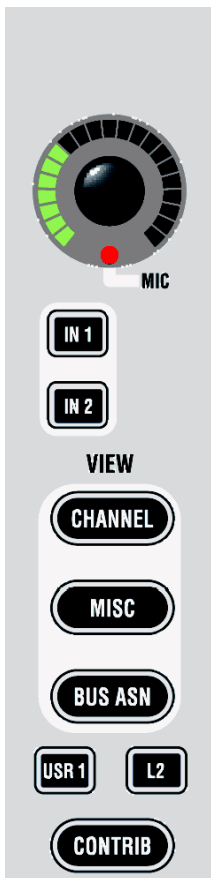

Rotary Control

If a Studer microphone preamplifier is connected, the analog gain will be controlled before the analog/digital converters. Otherwise the rotary control will adjust digital input gain. In any case, further control is available on the Vistonics® module. The control of a Studer microphone preamplifier is indicated by a small red **MIC** LED at the bottom of the rotary control.

⌚ IN1, IN2

Input Selector. Each channel has three patch points available (the patch is viewable on the Graphic Controller screen, [chapter 1.2.1](#)). Input 3 is patched to the internal generator's output by default, but can be changed by the user at any time. Only In1 and In2 can be switched directly from within each channel strip. In order to activate In3 (Generator), the user must click on the input switch area of the Channel View window within the graphic controller screen, as shown below.

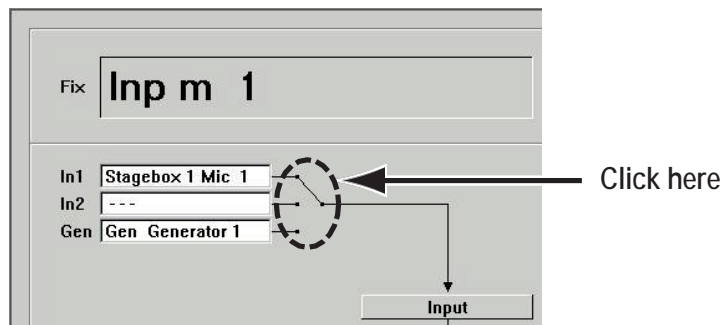

L2 (Layer 2 switch) If two-layer mode is enabled, this key switches to view the lower layer of the two.

2.7.1.1 Two-Layer mode

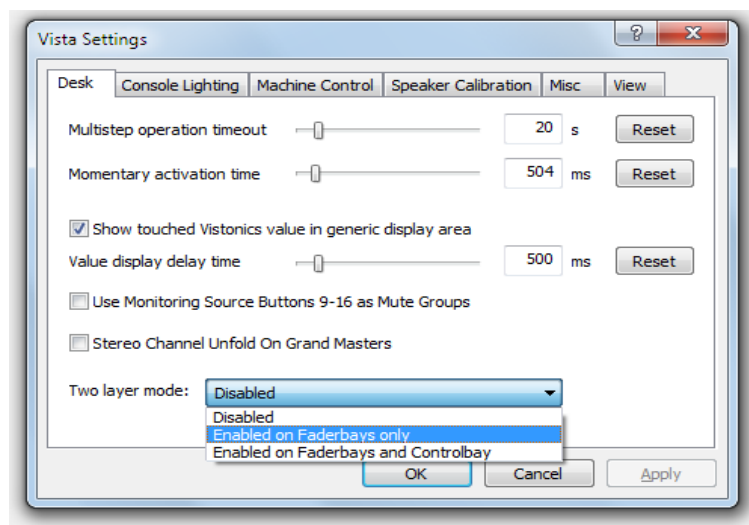

By activating 'Enabled on Faderbays...' in the Option - Vista Settings menu, the virtual desk may be reduced from six to three sections. The previous sections 4...6 now serve as a second (lower) layer of the console.

By pressing the L2 key on the channel strips, one individual channel strip can be switched between the upper and the lower half of the console. If a channel strip is currently displaying the third channel of section 1, it will afterwards display the third channel of section 4. This function may be helpful when working e.g. with backup microphones. In this way it is easy to switch to a different channel while leaving the other ones untouched.

Second Layer Disabled (Classic Operation):

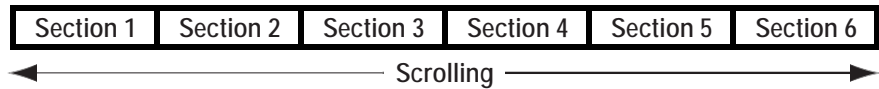

Second Layer Enabled:

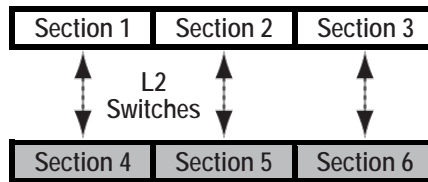

It is still possible to globally switch to the second layer by pressing the section navigator keys 4..6. This will activate the ↓ L2 ↓ keys on each strip of the console surface, indicating that the operator is now looking at the lower half of the console.

Both Layers at the Same Time:
real

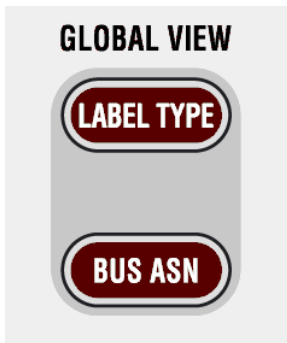

If the second layer option is activated, Vista 5 BE may display the label and time metering of both layers at the same time. In order to activate this label view, press LABEL TYPE several times until the label display area on the Vistonics® screen shows the labels of both layers. This label of the second layer appears only if there is a channel assigned to that strip on both layers. Use the Strip Setup dialog on the graphic controller screen to do this. Next to the label there is a small icon showing the level of the alternate layer (below, left). When switched to the second layer, the label lines are swapped, and the top line is showing the first layer label and metering (below, right).

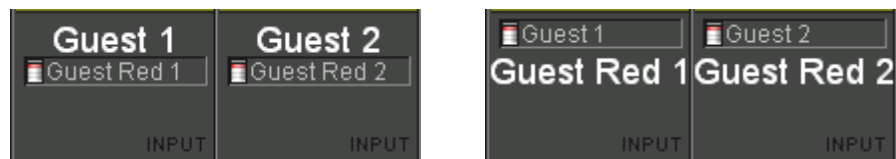

Note: The second layer is only displayed if the first layer is not empty.

2.8 Clipboard Libraries

On the Vista console it is possible to save and load clipboards to/from the internal file system or a USB memory stick. Clipboard files can contain one or more audio functions (e.g. EQ only, Dynamics only, or a combination of EQ and Dynamics) from a channel, or even can save complete channel settings. This is then representing a 'clone' of a channel, including bus assignment. By recalling such a channel from the clipboard library it is easily possible to bring the channels of a console into a certain status without even using snapshot functions.

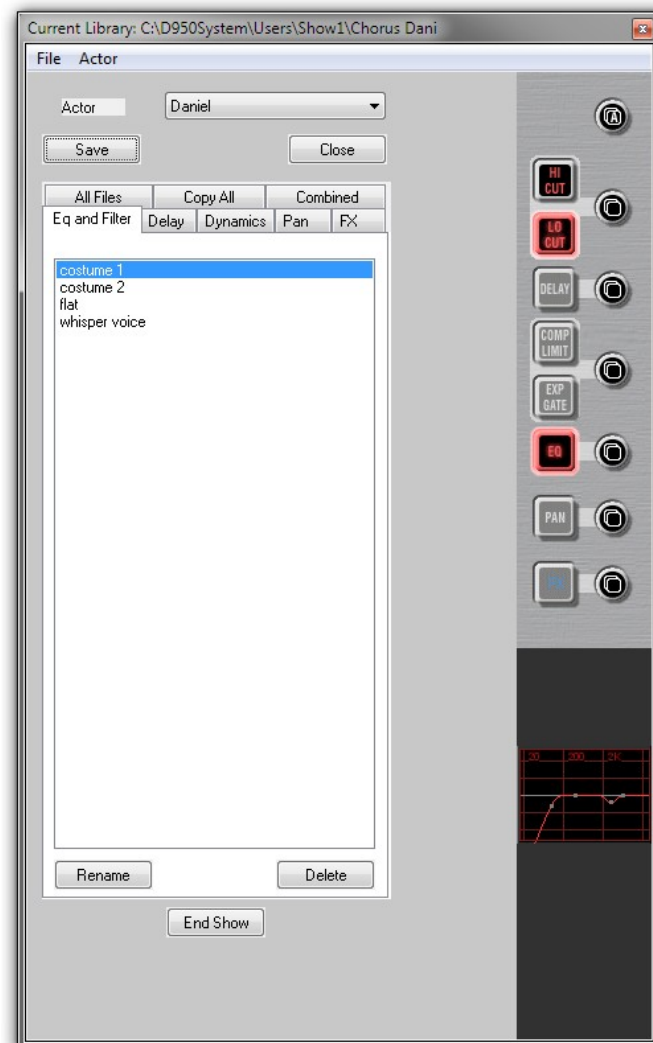

2.8.1 Clipboard Library Window

The Clipboard Library window is automatically opened whenever a paste function is pending on the Vista console. In order to open the window manually (e.g., to load the console clipboard with a saved value), select the corresponding icon from the toolbar or press the **OPTIONS F4** key on the console. It is also possible to select the window from the View menu.

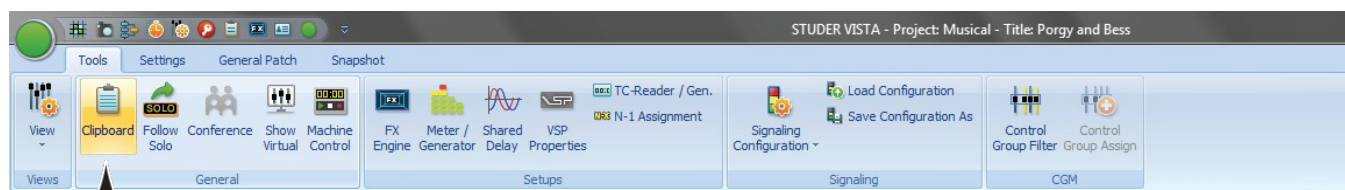

Clipboard Library Icon

The window may be closed by clicking on the close box on the top right corner of the window, by clicking on the Close button, or by pressing **F4** again.

2.8.2 Paste to Clipboard Library

- 1 Press the **⌘** (Copy/Paste) key on one or more audio functions of any channel strip(s) on the console surface. The Clipboard Library window will be opened automatically whenever a paste operation is pending.
- 2 Click on the half-lit **⌘** button in the window. If multiple audio functions are pending to be pasted (e.g. EQ and Dynamics settings), it is possible to click on the half-lit **⌘ A** (Copy/Paste All) button in the window. The pasted values will be graphically displayed.
- 3 The Save dialog opens, now you can give a name to the clipboard. It will be saved in the currently active Clipboard library.
- 4 Close the Clipboard Library window (see above).

2.8.3 Copy from Clipboard Library

- 1 Open the Clipboard Library window (see above).
- 2 If the desired library is not opened already (indicated in the title bar of the window), open the requested library by selecting 'Open Library' from the File menu.
- 3 Select the desired tab. Each of them represents a group of saved settings, which means that all listed files within a tab have the same type of audio function settings. 'All files' will show a list of *all* available clipboard files within this library, containing all the content of the other tabs. Files in the 'Combined' tab contain a combination of audio function settings. (e.g. EQ and Dynamics settings together). Files in the 'Copy All' tab contain complete channel settings.
- 4 Select a clipboard setting from the list by clicking on it. This will activate a preview function on the panel, shown at the right-hand side of the window. In this way it is easy to search for a special setting by looking at its graphical representation. The preview function lets you also identify which audio functions are contained in the selected clipboard file: The graphical representation of their 'On/Off' key will be grayed-out if there is no value present in this file.
- 5 Click on the **⌘** (Copy/Paste) button of the desired function in order to activate copying. The button will light, and all possible destination keys on the console surface will be half-lit. Shortcut: A double-click on the clipboard name in the list will activate copying of all contained audio values within that particular file directly.
- 6 Paste the value into one or more channels of the console, using the standard functionality. If the clipboard contained multiple audio settings, such as EQ and Dynamics, they may be pasted together by pressing the **⌘ A** (*Copy Paste All) key of the destination channel.

2.8.4 Rename/Delete a Clipboard Library File



- 1 Open the Clipboard Library window (see above).
- 2 Select the file you want to change or delete by clicking on it. Click on the 'Rename' or 'Delete' button of the Clipboard Library window in order to execute the desired action.
- 3 Close the Clipboard Library window (see above).

2.8.5 Clear the Display

By clicking on the 'Clear' button, the previewed settings are cleared, and no graphical indication is shown on the right-hand side of the window.

2.8.6 Update a Clipboard File

To combine, for instance, the current dynamics settings of a channel with the EQ settings that are already in the library, and to save them as one new set into the library, proceed as follows:

- 1 Open the Clipboard Library window (see above).
- 2 Select the desired, already saved EQ setting by clicking on it once. The EQ settings will be displayed graphically on the right-hand side of the window.
- 3 Press the  (Copy/Paste) key in the dynamics section of the source channel on the console.
- 4 Click on the half-lit  (Copy/Paste) button in the dynamics section of the window.
- 5 Both EQ and dynamics values will now be displayed on the right-hand side of the window.
- 6 The Save dialog opens. Once saved, the new, combined set will now be displayed within the 'Combined' tab.
- 7 Close the Clipboard Library window (see above).

2.8.7 Storage Format

Each clipboard is saved in a file with a **.cpy** extension. Multiple **.cpy** files form a library. A **.cpy** file may contain only one audio function (e.g. EQ settings) or a combination of any audio functions of a channel (e.g. EQ and Dynamics settings).

2.8.8 Import a Clipboard File from Another Library

- 1 Select 'Import Clipboard' from the file menu.
- 2 Navigate to the desired library.
- 3 Open the desired **.cpy** file. It will automatically appear and be saved within the currently active library.

2.8.9 Where are Clipboard Libraries Saved?

If you don't want to maintain multiple libraries on your console, you never have to change or define a name; just start directly, using the library functionality. The system will then use a library called **DefaultClipboardLib**.

If there are multiple libraries, you may select 'Open Library' from the file menu of the clipboard window in order to select another library to work with. It is also possible to save the whole library under a different name or to save it to a portable storage device such as a CD-R by selecting 'Save Library' in this file menu. Selecting 'New Library' in the file menu creates a new, empty library.

In technical terms, a library is a subdirectory of the **C:\D950System\Users** directory, it may also be located within any other user subdirectory. Selecting 'New User' creates a new user directory containing an empty Library called **ClipboardLib**.

2.9 Console Illumination

Standard gooseneck illumination may be connected to the rear of the Vista 5 BE desk (3Pin XLR, 3 locations). Brightness may be varied in intensity using the 'Option: Vista Settings' menu. There are two separate controls for the console lights (including Vistonics® backlights) and for the gooseneck illumination.

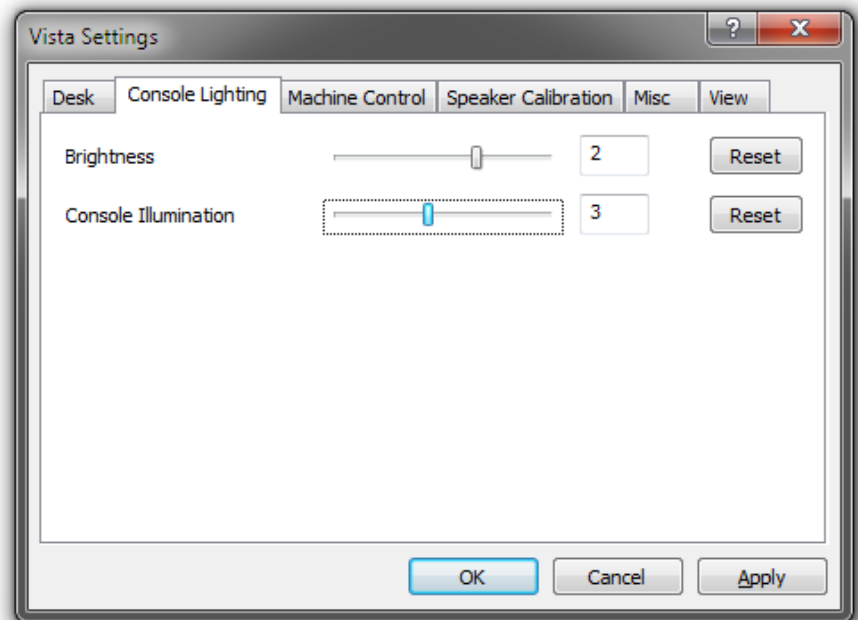

2.10 Optional TFT Level Meters

The TFT meterbridge option may also be retrofitted to the desk at a later point. Installation instructions are described on a sheet shipped with the meterbridge and also in [chapter 10](#).

Depending on console size, the TFT meterbridge features between two to four screens dedicated to the metering. One more screen is used for displaying either the GC information of the desk control PC, the metering PC or an external DVI signal; selection from these signals is done with the 3 keys labeled GC, INT and EXT that are located just below this screen. Therefore no external GC screen is required when using the TFT meter option.

The metering PC also features two USB sockets where a keyboard and a mouse may be connected whenever it needs to be operated separately (e.g. for a SW update).

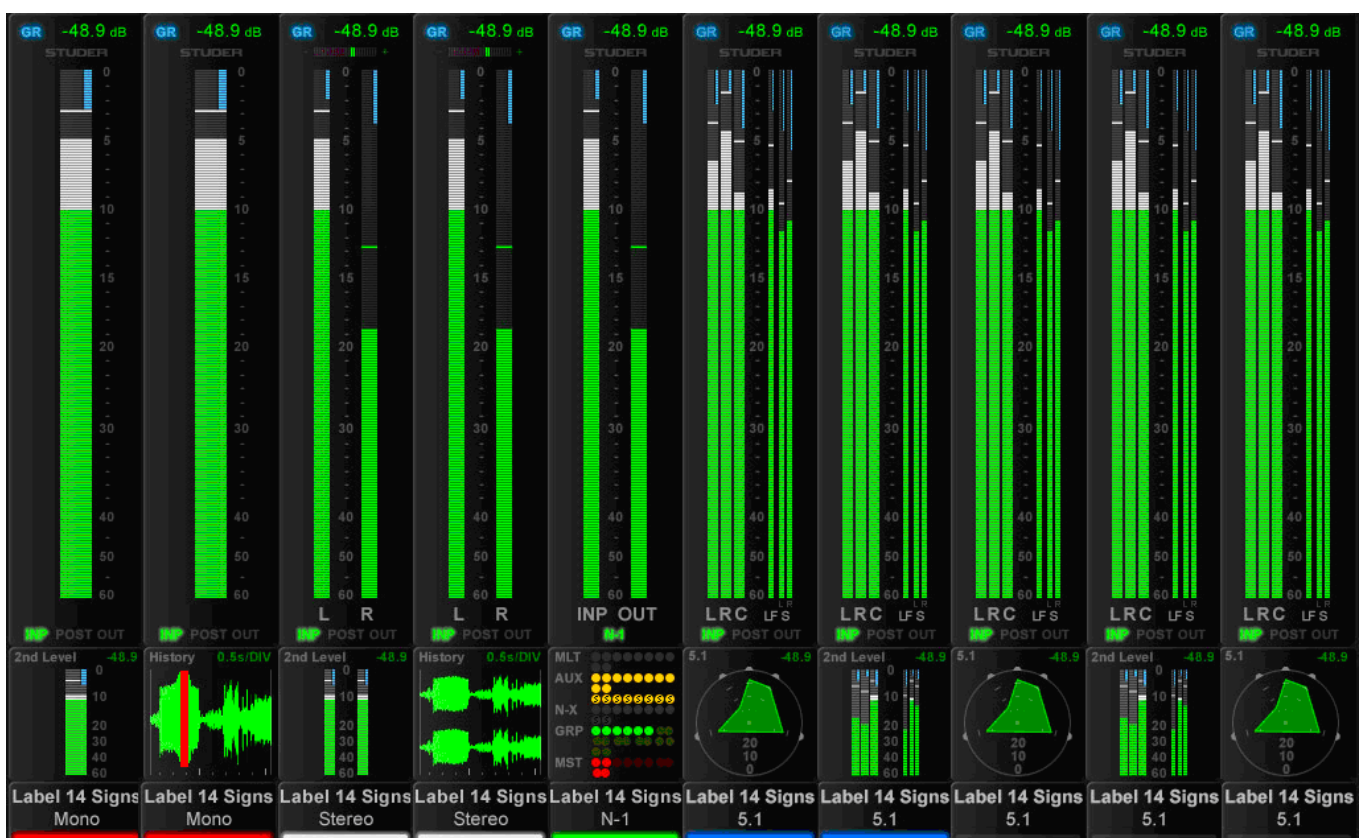

For all possible channel types - mono, stereo, 5.1 - the metering goes with it, as shown above. Priority was to have as large a bar graph meter as possible. The lower area is configurable for displaying different options, depending on the channel type, such as a surround image view, or a history diagram of incoming or outgoing signal waveforms, for spotting anomalies in the audio signal, such as overloads or signal loss.

Another option in the lower portion of the TFTs is a bus assignment view, giving an overview of the channel's current bus assignment, e.g. on a single channel where bus assignment is changed frequently.

The control bay metering differs in that it is mainly made to show output channels. More views are available, e.g. all AUX outputs, all groups, all programme masters, direct outputs, bus outputs, N-1s, matrix channels, etc. Four user pages can be configured. One has ten slots in one row, one 20 slots

in two rows, and two have 40 half-width slots in two rows. The two slots at the right of the control bay TFT screen continuously show PFL and CR levels.

The illustration on the previous page is an example of a meter screen with mono, stereo and surround channels and different views in the lower area – such as metering of the L2 channel, history, bus assignment and surround view. Further information is displayed as well, such as gain reduction or surround signal type.

Level Meters

The level meter bargraphs indicate digital peak values including headroom of mono, stereo, 5.1 and N–1 channels. The meter scale always is in dB_{FS} with 0 dB_{FS} at the top, with an additional overload segment clearly indicating overloads. Stereo meters feature a correlation meter on top of the meter bars, both on stereo inputs as well as on stereo master channels.

Above the level bargraph area gain reduction meters are added. Clipping is displayed by turning the white bargraph section (i.e., the segments above the headroom threshold) to red. The meter tap point can be selected from input, post fader and direct output level of the corresponding channel.

It is possible to use the red overload indicator above the meters to indicate a level just entering the configured headroom, rather than clipping. This is set in the GC’s ‘Meter/Generator’ window.

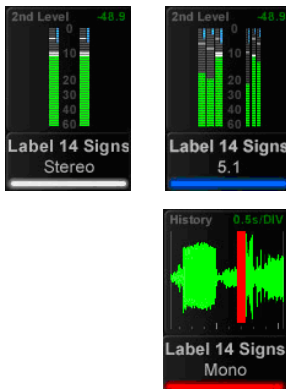

The area below the large bargraphs provides additional visual information, depending on the channel type and on what the operator prefers to see. When the desk is in ‘two layer’ mode, a smaller bargraph meter of the L2 channel (e.g. a spare microphone) is always shown.

Furthermore there is the option to display the audio waveform of the signal that has passed the channel, so the operator can see the history of the audio back to a configurable time of up to 50 seconds. The waveform of the audio-signal not only gives very clear information about signal loss or overload (which colours that part of the waveform in red) but also indicates the character of the signal, as in the age of DAWs most operators are used to interpret signals by looking at their waveform. The speed of the meter history view can be set in the Metering & Generator Settings window, as shown below.

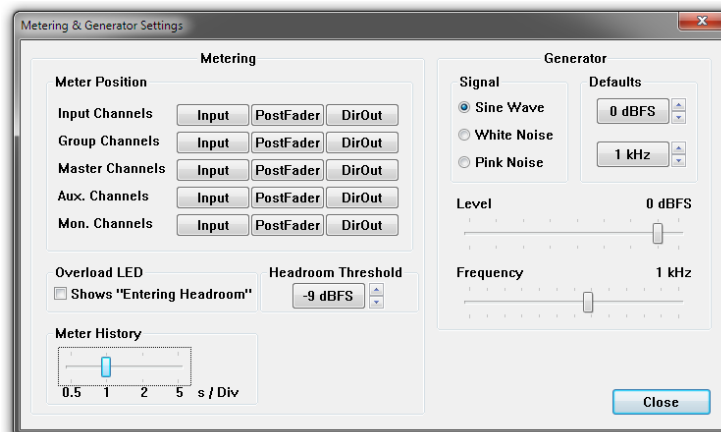

Surround channels come per default with a surround image view in the lower area, offering a spatial visualization of the surround signal. It allows spotting anomalies in a surround signal much faster than any other method.

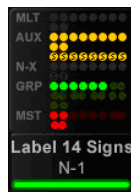

Alternatively, a bus assign view can be selected on any channel, giving a nice overview of the bus routing right below the bargraph meters. This may not be sensible for every channel but is useful for the ones where the bus assignment is changed frequently.



Control Bay

The control bay TFT metering is of multiple use. The **VIEW** keys *together with the* \hat{u} (*shift*) *key* allow switching between different views. All **VIEW** keys are of the momentary/latching type.

The **FOLLOW** key displays the metering that belongs to the channel assigned to the desk surface.

Then, there are view keys for all different type of master channels: Aux, Groups, program Masters, Matrix, etc., as well as output meter views of multitrack and n-1/x busses.

Moreover, there are four user keys that allow displaying any choice of channels of the mixing console on the four user pages. For assignment there is a page on the GC's Strip Setup window that lets assign up to 10 channels on the **USER 1** page, up to 20 channels in two rows on the **USER 2** page, and a maximum of 40 half-width channels in two rows on both the **USER 3** and **USER 4** pages.

The two meter slots at the right of the control bay TFT screen, however, continuously show PFL and CR levels.

Note Installation instructions for the TFT meter bridge for your **Vista 5** console are contained in the packaging of the meter bridge. You will find them too in the last chapter of this manual.

Setup TFT meter bridge setup information is given in [chapter 4.4.6.1.6](#).

2.11 Virtual Vista



‘Virtual Vista’ is a Windows application that can be used both as an online and offline editor. An indicator visible on all fader and control bay screens shows whether the editor is currently online (i.e., connected either to a desk/core system or to a core only), or offline. The former option can be thought of in particular as a fail-safe scenario in case there should be a serious problem with the desk.

It is strongly recommended that the computer on which Virtual Vista is installed has a minimum screen resolution of 1440 × 900 pixels.

Operating Modes

There are three different operating modes:

Offline



The offline editor is intended for setting up, preparing or changing shows without having access to the actual console. All parameters can be controlled. However, when working offline, no access to the monitoring facilities is available.

Online, With Desk

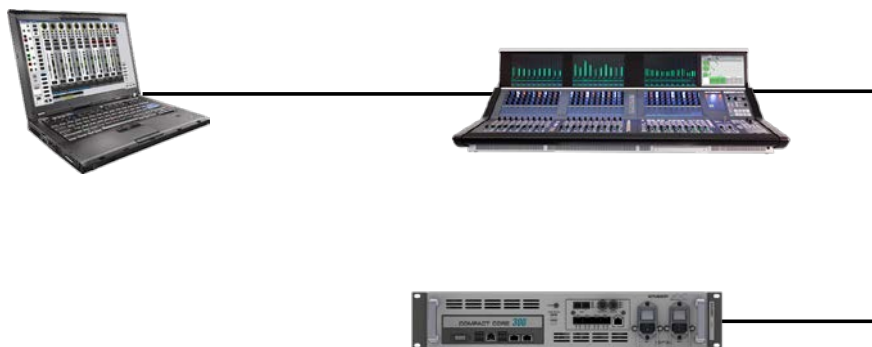

The online editor can be used as an alternate control possibility next to the console while the console is powered on and running. The two devices then run in parallel.

All changes made on one device are reflected on the other immediately. The online editor can also run on a wireless Tablet PC, so that the operator can walk away from the console and adjust parameters as he walks around. All parameters can be controlled.

Online, With Desk/Core Takeover

Virtual Vista can connect to the core only if there is a second network connection from the Virtual Vista computer to the second port of the SCore Live's bridge card.

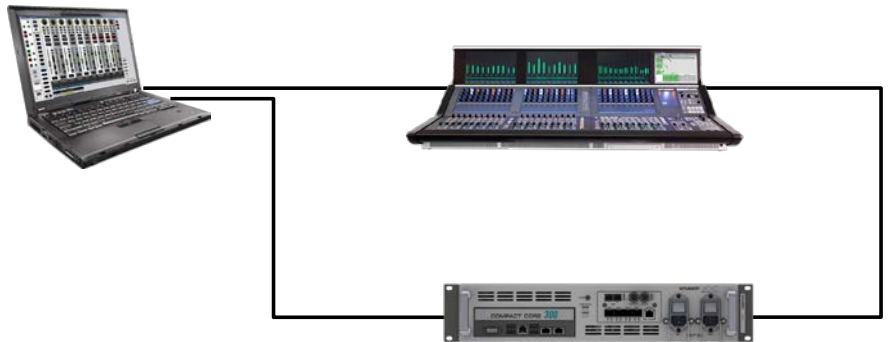

Should the desk fail, e.g. due to a power loss, the online editor can be used to continue the session. This can be thought of as an additional failsafe scenario. In such a case, the **CONNECT TO CORE** button can be used for taking over direct control of the core. By turning yellow, it indicates that the takeover process has been started.

However, since only one Vista instance can be used at a time, in such a case the Vista desk is disconnected from the core. Therefore using the **CONNECT TO CORE** button is recommended only if the desk can no more be operated.

Notes

The online editor has no access to monitoring facilities except PFL/Solo. Clicking PFL or Solo on a channel in the online editor will feed the selected signal to the PFL output of the desk.

After a takeover, Virtual Vista always starts in the same (static or dynamic) operating mode that was used to start the console. In dynamic mode, however, operation is much more convenient with the touch-sensitive desk controls. Virtual Vista only has a limited range of applications in dynamic mode, such as entering/editing labels.

2.11.1 Screen Layout

Since the Vistonics screen picture already uses 1024×768 pixels and additional space is required at the sides of and below the Vistonics screen area, the screen resolution should be at least 1440×900 pixels in order to display the complete Virtual Vistascreen.

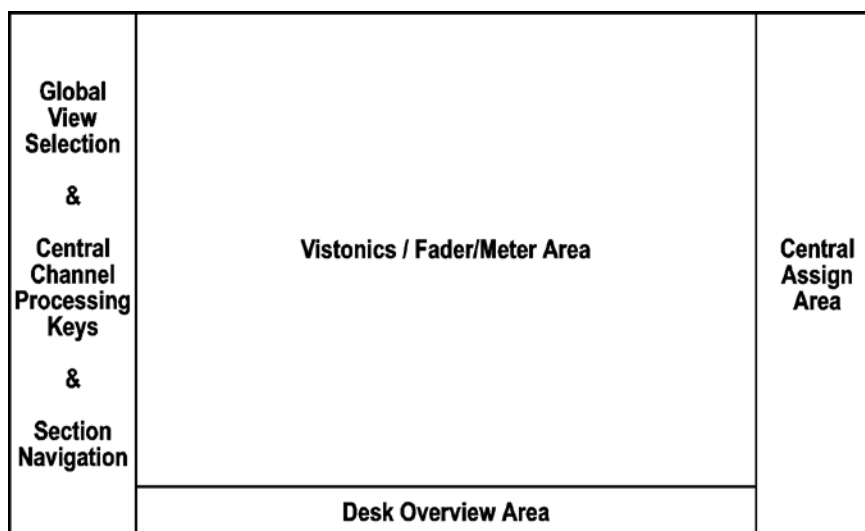

The space below the Vistonics screen area (desk overview area) is used to display a downsized overview of a virtual desk with up to 72 faders. This is the maximum possible desk size so that all possible titles can be viewed with the original strip setup and desk layout.

The area to the left of the Vistonics screen area shows the global view selection as well as central channel processing buttons (as used in Vista 5). Section navigation is at the bottom of this part. It will change depending on whether a fader bay or a control bay is currently selected.

On the right side of the Vistonics screen area a central assign fader strip is shown. It will change, too, depending on whether a fader bay or a control bay is currently selected.

The online/offline editor cooperates with Vista 5 (32 or 42 faders) as well as with the modular Vista 7, Vista 8 and Vista 9. For space considerations, mostly the Vista 5 operating concept is used.

2.11.2 Fader Bay View

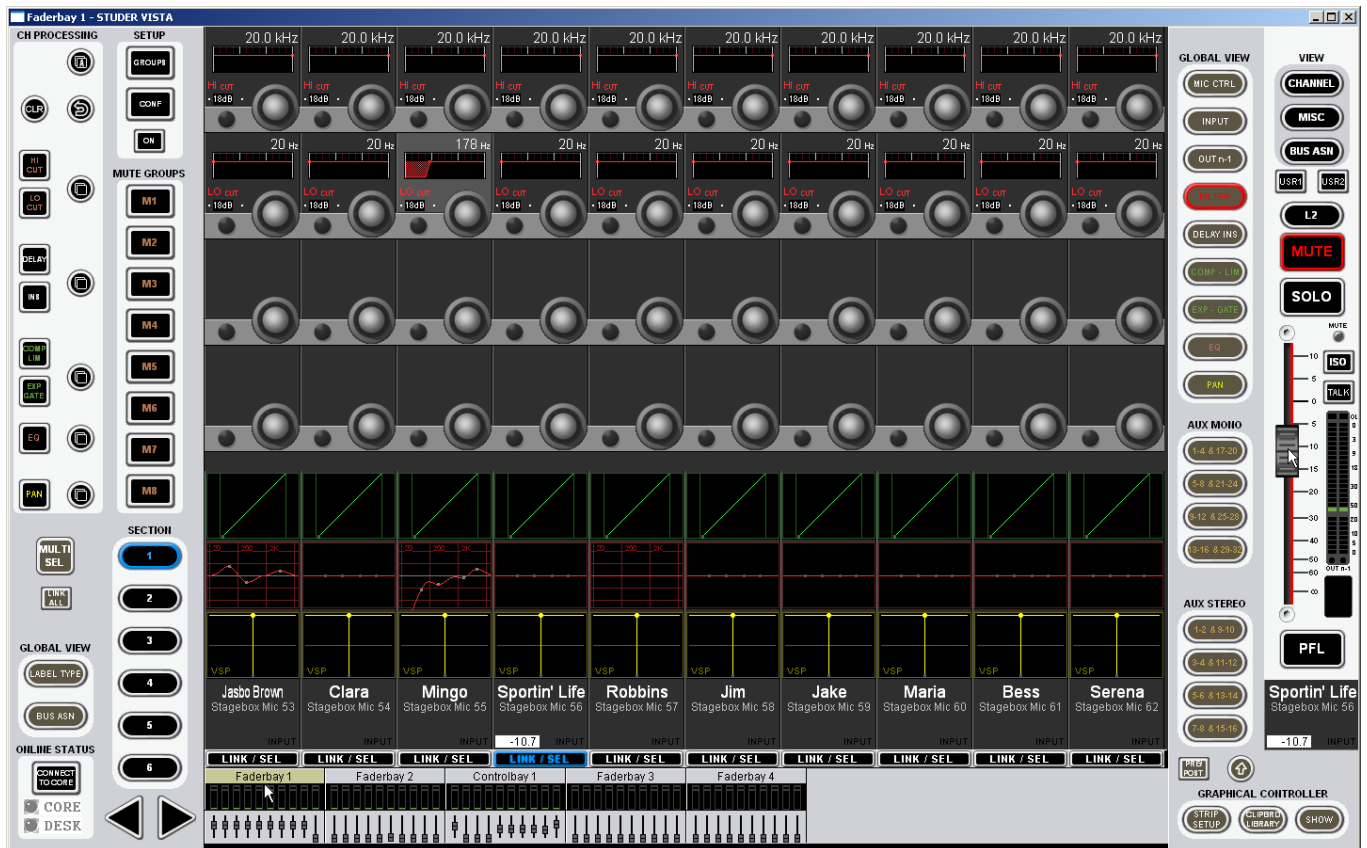

By clicking into the *meter area* of one of the fader bay icons (Faderbay 1...), the corresponding Vistonic view opens up. The upper part of the selected fader bay icon is highlighted in order to make clear which bay the operator is looking at.

The **LINK / SEL** button below the label area of the Vistonic screen is used to assign a single central fader that is displayed on the right-hand side. As long as the fader knob is 'touched' (i.e., the mouse pointer is located upon it and the left mouse button is pressed), the current fader value is displayed in both channel label fields, as shown in the screenshot above. If FaderGlow is active, this is reflected on the single fader as well.

Channel Grouping (Ganging)

The **MULTI SEL** button allows grouping channels for parallel operation. If a channel is selected with its **LINK / SEL** button, a click on **MULTI SEL** followed by a click on the next desired **LINK / SEL** button builds a two-channel group; a third channel is added to the group by another click on **MULTI SEL** and the next **LINK / SEL** button, and so on, until all the desired channels are grouped. The other way round, a click on **LINK ALL** and any **LINK / SEL** button selects all currently displayed channels; then, using the **MULTI SEL** and **LINK / SEL** buttons allows removing channels from the group.

There is a different, convenient way for building a channel group (or gang): Left-click-and-hold a **LINK / SEL** button, then – while still holding the left mouse button – right-click on another one. This will add all **LINK / SEL** buttons between the selected ones to the group. This works, by the way, also when right-clicking-and-holding first and left-clicking afterwards.

By clicking into the *fader area* of one of the fader bay icons (Faderbay 1...), the ten corresponding faders are shown instead of the Vistonics screen. The central fader on the right is then hidden. The lower part of the selected fader bay icon is highlighted – in order to make clear which bay the operator is looking at.



Operation The *hardware keys and buttons* (also the keys next to the rotary encoder knobs) on the screen can be operated by clicking on them either with the right or left mouse/trackball buttons. *Rotary encoder knobs* can be operated by clicking-and-holding them with the left mouse/trackball button (this corresponds to touching the real encoder knob on the desk surface); the parameter value is then underlined and displayed below the label area in addition. By moving the mouse or trackball to the right or upwards (or anything in-between) the parameter value is increased; by moving it to the left or downwards (or anything in-between) the parameter value is decreased.

2.11.3 Control Bay View

The control bay view can be selected from the desk overview area at the bottom of the screen. By clicking into the *meter area* of the control bay icon (Controlbay 1), the corresponding Vistonics view opens up, as shown below. The upper part of the selected control bay icon is highlighted in order to make clear which bay the operator is looking at. The **SECTION** navigator changes to the four-**FADER PAGE** navigator used in the control bay view. The global Vistonics **VIEW** selector of the control bay is shown next to the central fader.

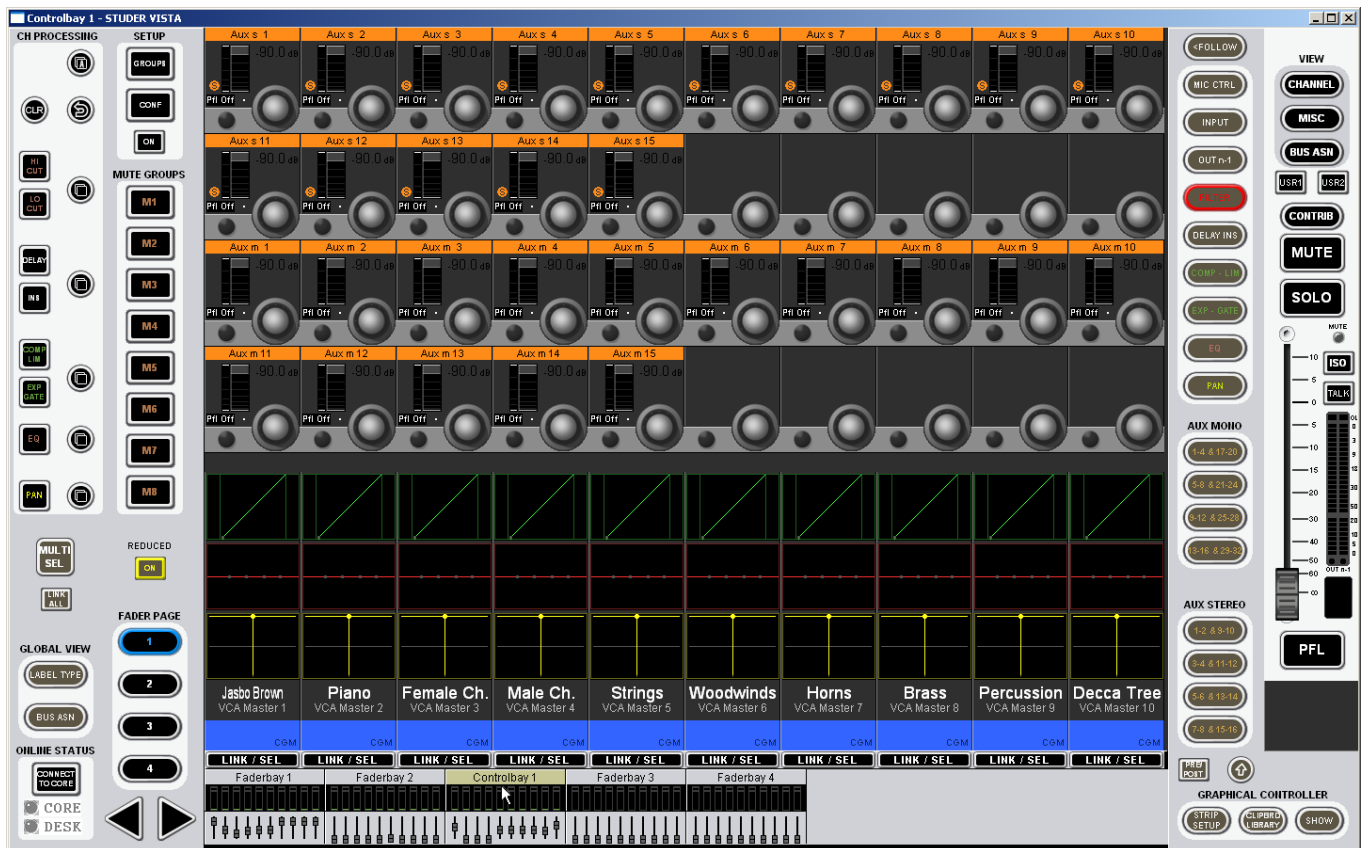

By clicking into the *fader area* of the control bay icon in the desk overview area, the ten faders of the control bay are shown. At the right of the screen the two **GRAND MASTER** faders are displayed.

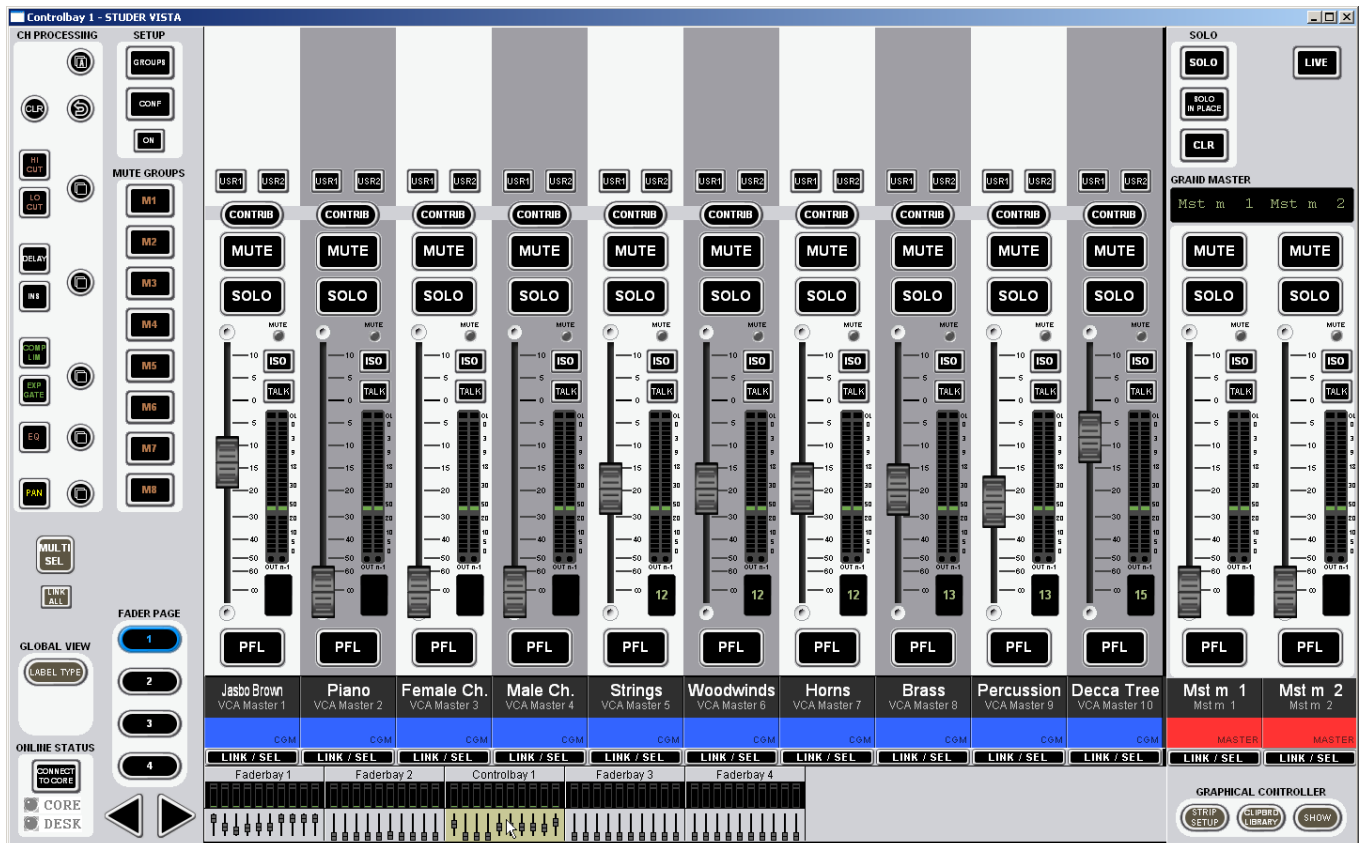

2.11.4 GC View



The GC general patch view opens after a single click on the **GRAPHICAL CONTROLLER – SHOW** button (at the bottom right of any of the fader and control bay windows), or by a click on in the taskbar, followed by a click on the general patch icon.

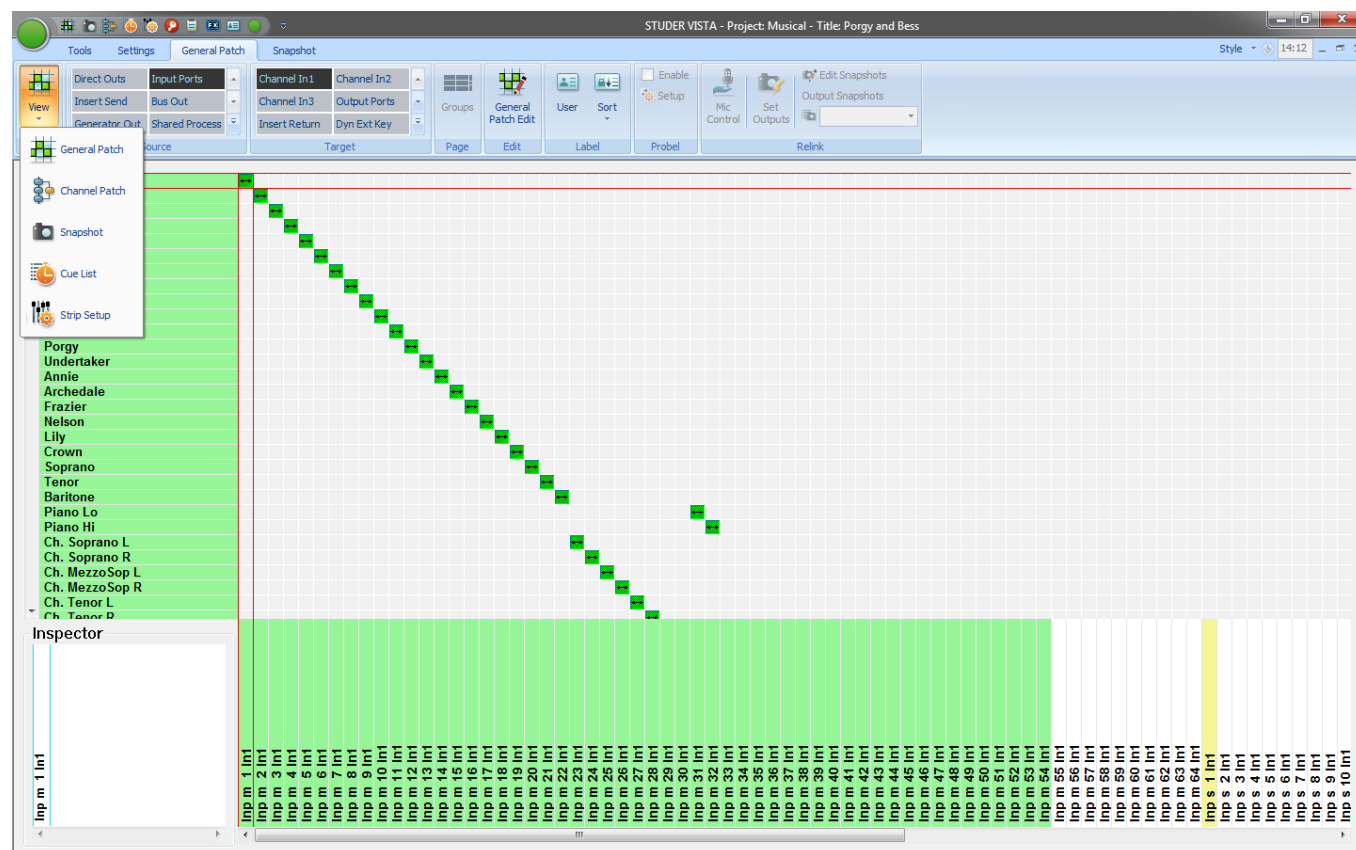

There are two more shortcut buttons as well: In order to have the clipboard library window displayed in front of the general patch view, click the **GRAPHICAL CONTROLLER – CLIPBRD LIBRARY** button; in order to have the strip setup window displayed in front of the general patch view, click the **GRAPHICAL CONTROLLER – STRIP SETUP** button.

In order to have the cue list or the theatre cue list displayed, either select from the Window - New Window menu, click on the 'New' icon and select from the dropdown menu, or click on the cue list icon. The other icons (channel patch, snapshot, and strip setup) work in the same way.

CHAPTER 3

| | | |
|----------|---|----------|
| 3 | Vistonics™ Parameters..... | 2 |
| 3.1 | Introduction | 2 |
| 3.2 | View Change..... | 2 |
| 3.2.1 | Global View Change | 2 |
| 3.2.2 | Channel-Related View Change..... | 3 |
| 3.2.3 | 5.1 Surround Input Channels..... | 4 |
| 3.3 | Global Views..... | 5 |
| 3.3.1 | Input | 5 |
| 3.3.2 | Pre-Amp Remote Control..... | 8 |
| 3.3.3 | Direct, Multi-Track and N–1 Outputs | 9 |
| 3.3.4 | Mono AUXes..... | 10 |
| 3.3.5 | Stereo AUXes..... | 11 |
| 3.3.6 | Filters | 12 |
| 3.3.7 | Delay and Insert | 13 |
| 3.3.8 | Dynamics | 15 |
| 3.3.8.1 | Compressor / Limiter | 15 |
| 3.3.8.2 | Expander / Gate..... | 17 |
| 3.3.9 | Parametric EQ..... | 19 |
| 3.3.10 | Panning..... | 20 |
| 3.3.11 | Global Bus Assignment View..... | 20 |
| 3.3.12 | Generic and Label Display Area | 22 |
| 3.4 | Channel-Related Views..... | 23 |
| 3.4.1 | EQ / Filter..... | 23 |
| 3.4.1.1 | Parametric EQ..... | 23 |
| 3.4.1.2 | Graphic EQ..... | 24 |
| 3.4.2 | Dynamics | 26 |
| 3.4.2.1 | Standard Dynamics | 26 |
| 3.4.2.2 | Standard Dynamics for 5.1 Surround Channels | 30 |
| 3.4.2.3 | Vintage Dynamics..... | 32 |
| 3.4.3 | Panning..... | 34 |
| 3.4.3.1 | Amplitude Panning..... | 36 |
| 3.4.3.2 | Upmix Panner (for Stereo Channels only) | 38 |
| 3.4.3.3 | Multi-Format Panning..... | 39 |
| 3.4.3.4 | VSP Panning | 41 |
| 3.4.3.5 | Panning for 5.1 Surround Channels..... | 43 |
| 3.4.3.6 | Microphone Simulation Tool (MST) – User Pan Mode..... | 45 |
| 3.4.4 | VistaMix (VMX)..... | 48 |
| 3.4.5 | General 5.1 Surround Channel View..... | 52 |
| 3.4.6 | Misc View (Miscellaneous Parameters)..... | 53 |
| 3.4.7 | Bus Assignment View..... | 54 |

3 VISTONICS™ PARAMETERS

3.1 Introduction

The desk can show different audio controls on the Vistonics screens. The controls differ in type of graphical viewing, shapes, and colors. If required, they are grouped together with frames in order to give the user maximum information without the need to read text on the display. The view of the audio controls can be changed either globally for the whole console, or locally within one channel.

For details on selecting the different functions please refer to [chapter 1.1.1](#).

3.2 View Change

3.2.1 Global View Change

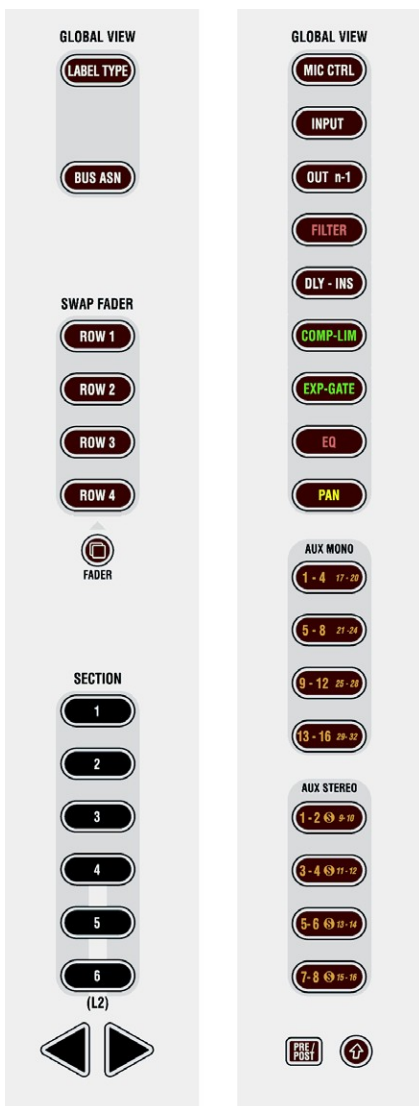

When pressing one of the keys in the **GLOBAL VIEW** areas, the view of the whole desk is changed. (The control bay remains with its own view unless ‘Follow’ is active.) Each channel strip will show parameters on up to four rotaries and their associated key. Only one global view key can be active at a time.

Some views will not cover all four rotaries, depending on the function (e.g. a 2-channel pan covers only the bottom rotary) or DSP configuration (e.g. if only 3 mono AUX buses are configured). After a view is activated, the corresponding key is lit. When this key is pressed again, all previous views (i.e., the ones other than the currently pressed global view key) will be blanked. So the selection of parameters can be done in a quite flexible way. When pressing **AUX MONO 1-4** followed by **PAN**, the result will be **AUX 1-3** on rotaries 1 through 3, and pan on rotary 4. When pressing **PAN** a second time, rotaries 1 through 3 are blank and pan will still be displayed on rotary 4.

No rule without exceptions:

- For selecting mono or stereo AUX views beyond 16, the \hat{u} key (Shift) must be active.
- When the **PRE / POST** key in the fader bay’s **GLOBAL VIEW** area is active, the AUX views change to pre-/post-fader selection.
- As a special global view change, the **GLOBAL VIEW: BUS ASN** key lets the EQ, Dynamics and Pan curves on the lower part of the TFT display disappear and shows all bus assignments instead (see [chapter 3.3.11](#)). Pressing **GLOBAL VIEW: BUS ASN** again makes the curves reappear.

3.2.2 Channel-Related View Change



The views listed below can be activated in a channel strip. Then the corresponding values of this particular channel are shown.

- Dynamics (by touching the green dynamics view on the screen)
- EQ (by touching the red EQ view on the screen)
- Panning (by touching the yellow pan view on the screen)
- Bus Assignment (by pressing **VIEW: BUS ASN** – as opposed to the **GLOBAL VIEW: BUS ASN** key described in [chapter 3.2.1](#)).
- Channel parameters (by pressing **VIEW: CHANNEL**); this shows the remaining controls, together with AUX and covers all 40 rotaries.
- Miscellaneous parameters (by pressing **VIEW: MISC**); this shows a reduced view of EQ, dynamics, and pan parameters at the same time; it covers all 40 rotaries.

When touching a curve on the TFT, a picture with the available parameters appears on the rotaries. The picture is 'left-aligned' to the selected channel. When touching the dynamics curve of the third channel strip, for instance, the corresponding graphics are shown on the rotary rows 3 through 7, since the dynamics parameters are covering five rows of rotaries. While the function is unfolded on the display, the corresponding graphic field (e.g. showing the dynamics curve) is highlighted, as shown in the picture on the left.

In one fader bay, two audio functions can be shown at a time, either by using the **MULTI SEL** key, or by simultaneously touching two graphics. In this case, one of the two functions is displayed left-aligned, the second one right-aligned. If there is any room between them, they are interleaved by one or more strips in black. The rotaries on these blackened strips are not used.

3.2.3 5.1 Surround Input Channels



With the 5.1 surround input channels, the user has input, EQ, dynamics and panning sections completely designed for premixed 5.1-channel input sources. The main goal is that he can adjust the most important parameters directly with a touch on the Vistonics screen, without the need to ‘spilling’ single mono or stereo channels to additional faders, while other important sources would be hidden and become unavailable. A global view of a 5.1 input channel is shown below.

3.3 Global Views

3.3.1 Input

Press **GLOBAL VIEW: INPUT GAIN**.

For input sources IN 1, IN 2, and GEN (selection with the hardware keys below the channel meters), an input control view is available. The number of functions available on Input or Output channels, as well as on mono or stereo channels, depends on the active configuration.

A DC reject filter is always active in each channel.

For input and output channels, the following parameters are available:

| Parameters | MONO INPUT | | | STEREO INPUT | | | MONO GROUP | | | STEREO GROUP | | | MONO/STEREO MASTER | | | MONO/STEREO AUX | | |
|------------|------------|-----|-----|--------------|-----|-----|------------|-----|-----|--------------|-----|-----|--------------------|-----|-----|-----------------|-----|-----|
| | IN1 | IN2 | GEN | IN1 | IN2 | GEN | IN1 | IN2 | GEN | IN1 | IN2 | GEN | IN1 | IN2 | GEN | IN1 | IN2 | GEN |
| PHASE | X | X | X | X | X | X | X | X | X | X | X | X | - | - | - | - | - | - |
| XY/MS-MODE | - | - | - | X | X | - | - | - | - | X | X | - | - | - | - | - | - | - |
| INPUT MODE | - | - | - | X | X | - | - | - | - | X | X | - | - | - | - | - | - | - |
| INPUT GAIN | X | X | X | X | X | X | X | X | X | X | X | X | - | - | - | - | - | - |

Mono Channel: Stereo Channel:



Input Parameters for Mono Channels *only*:

- PHASE** Two positions are provided (select either with the key or the rotary):
- NORM/Off, in phase (default setting).
 - REV/On, out-of-phase.

Input Parameters for Mono and Stereo Channels:

- GAIN** Input gain can set in 1 dB steps from -24 dB (attenuation by 24 dB) to +24 dB. Default value: 0 dB.
- In a stereo channel, left and right input gains are treated simultaneously.

Input Parameters for Stereo Channels *only*:

- PHASE** Four different positions are provided:
- ++, in phase (default setting).
 - -+, left channel (or input A) out-of-phase.
 - +-, right channel (or input B) out-of-phase.
 - --, left and right channels (or inputs A and B) out-of-phase.

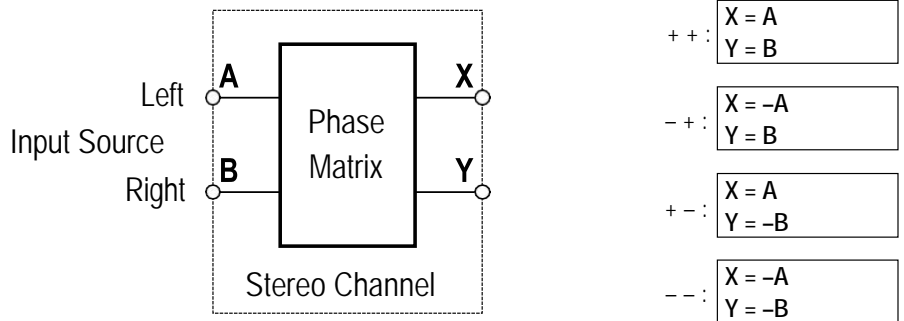

- MS on/off** Two different positions are provided:
- MS off (default setting), for coincident XY stereo microphone setups.
 - MS on (Mid/Side information), used for decoding MS information from appropriate coincident stereo-microphone arrays.

- 2 CH MODE** Five different positions are provided:
- Stereo (default setting).
 - Left and right signals are swapped.
 - Left signal only is routed to both left and right outputs.
 - Right signal only is routed to both left and right outputs.
 - Mono, left and right signal mixed together (-3 dB) and routed to both left and right outputs.

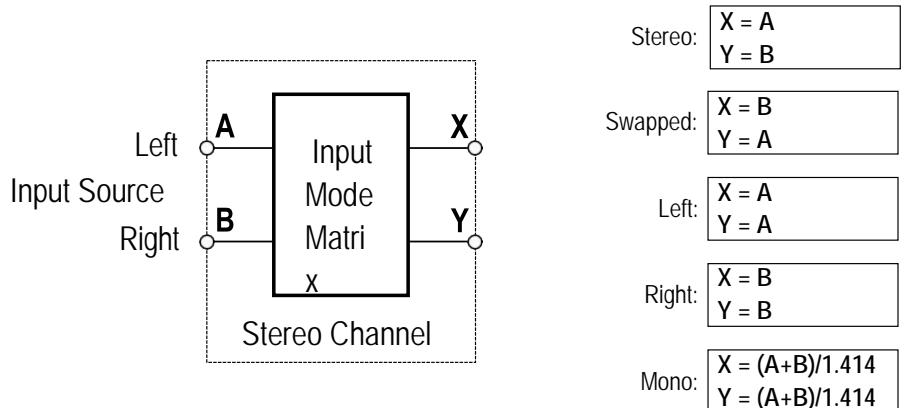

If a channel contains the input balance function (configuration tool name 'Input MS mode Bal Phase'), a balance control will be available in the pan page. This balance control is actually set *before* the mono switch in the signal path, within the input section of the channel. Hence it is possible to use the

input balance function to correct the levels of two channels feeding a stereo input channel, and then add them together to become a mono sum. A practical example is the feed of a stereo channel from a VTR, one channel containing ambient signals and the other one being the commentator. In this case the 2-channel mode is set to 'mono', and the input balance function is used to correct the mix between ambient and speech signals.

5.1 (Surround) Channels

Compared with mono or stereo channels, the global input control section of a surround input channel is slightly different: There is no phase control switch, and the **2 CH Mode** selector has been replaced by **5.1 ORDER**.



DIG 1 GAIN As it is the case with mono or stereo channels, the digital gain stage acts as a trim after the A/D converter. Input gain can be set in 1 dB steps in a range of ± 24 dB. The default value is 0 dB. In a 5.1 channel, all six surround input legs are treated simultaneously.

5.1 ORDER Like the **2 CH MODE** function in a stereo channel, this functionality provides a kind of patching within the 5.1 channel. The bus order in Vista consoles with SW V4.0 has been changed according to the ITU standard (L, R, C, LFE, Ls, Rs). The **5.1 ORDER** selector allows converting different surround formats to the ITU order.

| Format | Input Channels | ⇔ ITU Output Channels |
|-------------------------|-----------------|-----------------------|
| ITU | L R C LFE Ls Rs | L R C LFE Ls Rs |
| Studer (SW before V4.0) | L R C Ls Rs LFE | |
| Film | L C R Ls Rs LFE | |
| L R | L R | |

3.3.2 Pre-Amp Remote Control

Press GLOBAL VIEW: A / D CTRL.

Various analog functions of the D21m mic/line input cards can be remote controlled. On the 5.1 surround input channels these controls are linked for all six legs of the surround signal. All mic/line cards provide an active split output for each microphone channel.



MIC GAIN Gain setting in steps of 1 dB, within a –26 through +60 dB range (depending on the current nominal level and headroom settings). The display indicates the gain applied to signals passing through the microphone pre-amplifier card.

HPF On/Off Analog low-cut filter for the microphone-level input, with a fixed cutoff frequency of 75 Hz and a slope of 12 dB/octave is available.

SOFT CLIP On/Off A soft clip function is available on all channels and can be activated individually. This ‘analog limiter’ may prevent nasty clipping noises in case the audio level should be too high. We recommend activating this function during live productions, since audio is not influenced below about –6 dB_{FS}.

48 V On/Off Toggles phantom power on/off for the microphone input.

A INSERT On/Off (Not supported by transformer-balanced microphone pre-amplifier cards A949.0447). An analog insert point is made available by inserting an optional analog insert card. Its send output is always active at line level, and the return path may be activated by the corresponding switch on the console.

MIC CTRL Free/Other/Owned Toggle switch for remote control of the analog mic/line input parameters. In case of I/O sharing operation this switch is also used for the mic takeover procedure (refer to [chapter 8.3](#)).

3.3.3 Direct, Multi-Track and N-1 Outputs

Press **GLOBAL VIEW: OUT n-1**.

This view allows controlling the level of the Direct, Multi-Track and the channel's contribution ('send') to the N-1 bus(es). If the channel is assigned as a bus owner of an N-1 bus, the N-1 bus outputs is controlled from here as well.

From surround input channels, N-1 mono buses are fed with an ITU-compatible mono down-mix of the surround signal. N-1 stereo buses are fed accordingly with an ITU-compatible stereo down-mix.



- | | |
|------------------------|--|
| DIR OUT On/Off | Direct output on/off. |
| DIR OUT Rotary | Direct output level, MUTE (i.e. $-\infty$ dB) to +10 dB. |
| Mtrk | Multi-track output level, MUTE (i.e. $-\infty$ dB) to +10 dB. |
| Pan On/Off | Allows panning of the channel's output signal to the multi-track bus if set to 'Pan On', in addition to the standard channel pan. The panning is adjusted with the usual Pan controls. |
| n-1 OUT On/Off | N-1 Output on/off. |
| n-1 OUT Rotary | N-1 Output level, MUTE (i.e. $-\infty$ dB) to +10 dB. |
| n-1 SEND Rotary | Send level ('contribution') of this channel to all assigned N-1 buses (default: 0 dB). |

3.3.4 Mono AUXes

Press one of the GLOBAL VIEW: AUX MONO keys.

The mono AUX view provides selection of the AUX bus (ON/OFF), send level adjustment, and pre-/after-fader switching. From 5.1 surround channels, monoAUX sends are fed with an ITU-compatible mono down-mix.



AUX m x On/Off Mono AUX bus selection. Other mono AUX bus views can be selected as well (5...8, 9...12, etc.).

AUX m x Rotary The send levels for mono AUX 1 through the maximum number configured can be adjusted using this rotary encoder; adjustment range is from Mute ($-\infty$) through +10 dB.

AUX m x Pre/Post When the **PRE / POST** key in the fader bay's **GLOBAL VIEW** area is active, the Vistonics view changes as shown above at the right. The signal sent to the mono AUX bus can be selected **Pre** (pre-fader, i.e. *before* the fader) or **Post** (post-fader, i.e. *after* the fader).

3.3.5 Stereo AUXes

Press one of the **GLOBAL VIEW: AUX STEREO** keys.

The stereo AUX view provides selection of the AUX bus (ON/OFF), send level adjustment, pre-/after-fader switching, and pan setting. From 5.1 surround channels, stereo AUX sends are fed with an ITU-compatible stereo down-mix.



Aux s x On/Off Stereo AUX bus selection. Other stereo AUX bus views can be selected as well (5...8, 9...12, etc.).

Aux s x Rotary The send levels for stereo AUX buses can be adjusted using this rotary encoder; adjustment range is from MUTE (i.e. $-\infty$) through +10 dB.

AUX s x Pre/Post When the **PRE / POST** key in the fader bay's **GLOBAL VIEW** area is active, the Vistonics view changes similar to the one shown above in the center. The signal sent to the stereo AUX bus can be selected from **Pre** (pre-fader, i.e. *before* the fader) or **Post** (post-fader, i.e. *after* the fader).

AUX s x Pan Rotary The Stereo Aux Pan view is activated by pressing the **PAN** key below the **GLOBAL VIEW - AUX** keys. By default, the Aux panner is linked to the channel pan value (Follow On), as shown above at the right. If the channel panning is 'multi-format', only the L/R setting is used for the Aux pan.

AUX s x Follow On/Off If individual Aux pan settings are required, the default setting ('Follow On', i.e. the Aux pan setting follows the channel pan) may be switched off; the Aux panner is then adjusted with the Vistonics rotary encoder.

3.3.6 Filters

Press **GLOBAL VIEW: FILTER**.

This view enables the user to control the parameters of the hi- and low-cut filters. These filters are available on the channel-related EQ views as well, refer to [chapter 3.4.1](#). In that chapter you will also find the parameter details. The two filter sections are activated with the **HI CUT** and **LO CUT** hardware keys in the **CHANNEL PROCESSING** section.

For 5.1 surround channels, the high- and low-cut filter parameters applied here are valid for all surround signal legs, *except for the LFE*. For further information on this subject, please refer to [chapter 3.4.1](#).



- | | |
|-----------------------------|--|
| HI CUT/LO CUT x dB | Slope setting for the high- and low-cut filters, selectable from 12, 18, and 24 dB/octave (key toggles 12, 18, 24, 12...). |
| HI CUT/LO CUT Rotary | Cutoff frequency adjustment for both the high- and low-cut filters: 20 Hz through 20 kHz, in 120 steps. |

3.3.7 Delay and Insert

Press **GLOBAL VIEW: DLY-INS**.

This view enables the user to control the delay and insert parameters.

Please note: The two sections are activated with the **DELAY** and **INS** hardware keys in the **CHANNEL PROCESSING** section.

For 5.1 channels the delay processing block has a maximum delay time of 700 ms (as opposed to the standard 240 or 100 ms delay in the mono or stereo channels).



Delay Parameters:

The delay value is set using the rotary encoder. It is displayed as a *physical distance* (meters) and as a *delay time* (either samples or milli-seconds).

DELAY On/Off is selected with the **DELAY** hardware key in the **CHANNEL PROCESSING** section.

DELAY Rotary Delay time can be set in a range from 0 through 100 ms (or, depending on the system configuration, to a maximum of 240 ms). The value is displayed as a delay distance as well (from 0 cm up to 81.5 m, depending on the system configuration).

DELAY time/smpl Selects the delay setting in samples ('smpl' – fine setting) or milli-seconds ('time' – coarse setting).

Insert Parameters:

The insert section provides selection and control of the insert point (INSERT ON/OFF) and the INSERT MIX function (ON/OFF), plus defining the dry/wet mix ratio (INSERT MIX %).

INS(ert) On/Off is selected with the **INS** hardware key in the **CHANNEL PROCESSING** section. On' activates the insert return signal; 'off' selects the Input Signal (that corresponds to the insert send signal).

INSERT MIX On/Off On activates the insert mix function; Off selects only the insert return signal. When the insert mix function is set to On, the ratio of the dry (send) to the wet (return) signal depends on the selected mix ratio. In other words, mixing between the insert send and the insert return signals is possible.

INSERT MIX Rotary If the MIX function is On, this parameter allows mixing or blending of the dry (send) and the wet (return) signals. 0% setting: dry signal only; 100% setting: wet signal only.

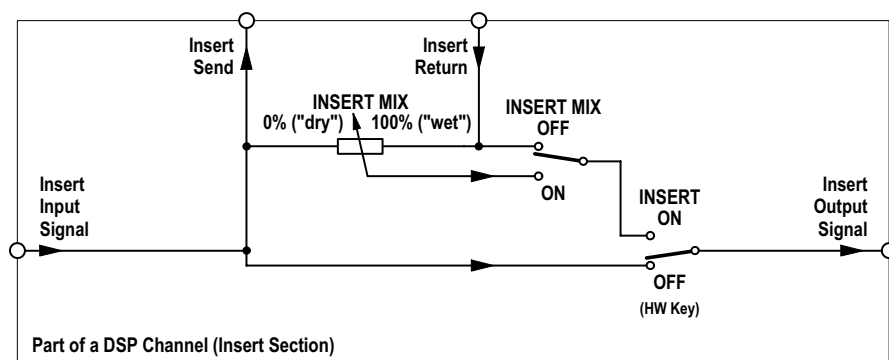

Note *If the insert is routed to an external, non-digital device (such as an analog compressor patched through D/A and A/D converters), the delay introduced by the D/A-A/D conversion will result in a comb-filter effect if the insert return and mix are active and the **MIX %** is set anywhere between DRY and WET. When inserting external, analog devices, the **MIX %** should always be set to WET (i.e., to 100%), unless this comb-filter effect is desired - or the delay is compensated by adding delay on other signal paths. The latter is made very easy by using a gang and adding delay to multiple console channels.*

3.3.8 Dynamics

Standard/Vintage Dynamics

Since SW version 4.0 there is an alternative VMC processing block available for mono and stereo channels. It is called ‘Vintage Dynamics’ and consists of a compressor that can be used together with an expander/noise-gate. The design focus was very clearly set on the compressor. This compressor algorithm provides an alternative to the current dynamics section in the Vista consoles, which has been described as rather ‘transparent’.

For some applications, however, a compressor can be utilized in a more pronounced way, i.e., as an effect itself. For this purpose the ‘vintage dynamics’ was created. It is targeted to be flexible enough for different types of sound coloration including extreme and unusual settings, but does not feature a dedicated limiter.

Selection between standard or vintage dynamics is performed using the Session Configuration Tool, refer to [chapter 6.4.3.2](#).

Vintage Dynamics Block Diagram:

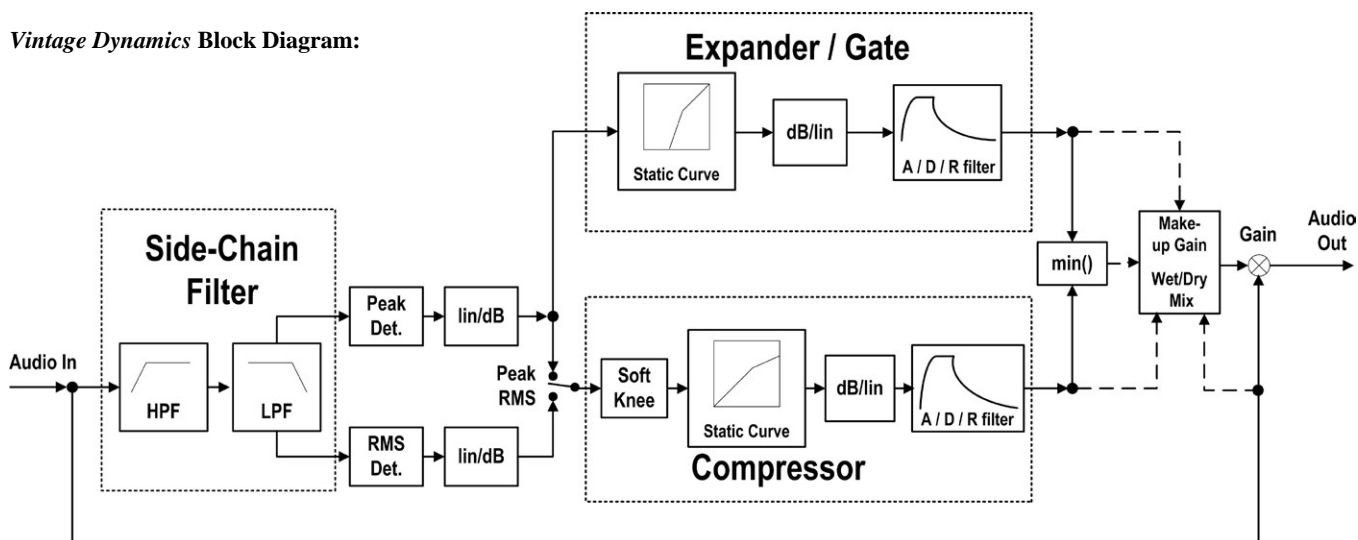

The *standard* dynamics section features a limiter, while the *vintage* dynamics section only has compressor parameters – knowing this might be helpful when sitting at the console and having to discriminate the dynamics sections. In the illustration on the next page, the left-hand channel shows the standard dynamics section parameters, the right-hand channel the ones of a vintage dynamics section.

Note As opposed to SW V4.1 and 4.2, *both* dynamics sections may be used now with sampling rates of up to 96 kHz.

3.3.8.1 Compressor / Limiter

Press **GLOBAL VIEW: COMP LIMIT**.

This view enables the user to control the *most important* parameters of the dynamics section’s compressor and limiter parts. The *complete* parameter set is available on the channel-related dynamics view, refer to [chapter 3.4.2](#). There you will also find all parameter details.

For 5.1 surround channels, the compressor and limiter settings are valid for all surround signal legs *except the LFE*. For further information on this subject, please refer to [chapter 3.4.2.2](#).

The compressor and limiter parts of the dynamics section can *simultaneously* be activated with the **COMP LIMIT** hardware key in the **CHANNEL PROCESSING** section, in addition to the individual on/off keys described below.

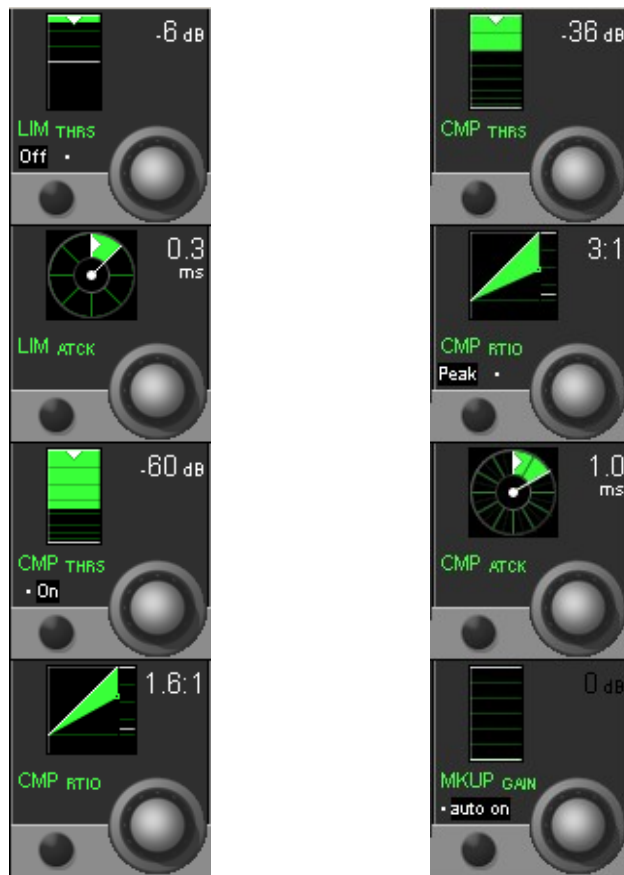

Standard Dynamics Section (left):

LIM THRS Rotary

The limiter threshold can be adjusted in 1 dB steps from 0 dB_{FS} to -48 dB_{FS}. The limiter threshold corresponds to the output level.

LIM On/Off

Individual limiter on/off control.

LIM ATCK Rotary

The limiter attack time can be adjusted in 9 steps within a 200 μs to 1 ms range.

CMP THRS Rotary

The compressor threshold level can be adjusted in 1 dB steps from 0 dB_{FS} to -96 dB_{FS}.

CMP On/Off

Individual compressor on/off control.

CMP RTIO Rotary

The compressor ratio can be adjusted from 1:1 (no compression) to 20:1 (heavy compression).

Vintage Dynamics Section (right):

CMP THRS Rotary

The compressor threshold level can be adjusted in 1 dB steps from 0 dB_{FS} to -96 dB_{FS}.

CMP RTIO Rotary

The compressor ratio can be adjusted from 1:1 (no compression) to 40:1 (extra heavy compression).

CMP peak/RMS

Level detection mode: peak or RMS

CMP ATCK

The compressor attack time can be adjusted in 64 steps within a range of 0.2 ms to 250 ms.

MKUP GAIN auto on/off

‘auto on’ automatically compensates a level loss caused by the dynamics processing. ‘auto off’ activates the manual MKUP GAIN rotary control.

MKUP GAIN Rotary

To manually compensate a level loss caused by the dynamics processing, adjustable in 1 dB steps from 0 through +24 dB.

3.3.8.2 Expander / Gate

Press **GLOBAL VIEW: EXP GATE**.

This view enables the user to control the *most important* parameters of the dynamics section's expander and gate parts. The *complete* parameter set is available on the channel-related dynamics view, refer to [chapter 3.4.2](#). There you will also find all the parameter details.

For 5.1 surround channels, the expander and gate settings are valid for all surround signal legs *except the LFE*. For further information on this subject, please refer to [chapter 3.4.2.2](#).

Note The expander and gate parts of the dynamics section can be activated *simultaneously* with the **EXP GATE** hardware key in the **CHANNEL PROCESSING** section, in addition to the *individual* on/off keys described below.

Standard Dynamics Section

EXP THRS Rotary The expander threshold level can be adjusted in 1 dB steps from 0 dB_{FS} to -96 dB_{FS}.

EXP On/Off Expander on/off.

EXP RTIO Rotary The expander ratio can be adjusted from 1:1 (no expansion) to 20:1 (heavy expansion).

GATE THRS Rotary The gate threshold level can be adjusted in 1 dB steps from 0 dB_{FS} to -96 dB_{FS}.

GATE On/Off Gate on/off.

GATE ATCK Rotary The gate attack time can be adjusted in 9 steps within a 200 μs to 1 ms range.

GATE hyst on/off

The gate hysteresis function provides an offset between the un-mute and mute thresholds. So the gate will remain open (un-muted) at a level slightly lower than the one required to open it in order to avoid effects such as chattering.

Vintage Dynamics Section

There are two different views for the vintage expander/gate view; one of them (below left) is displayed when pressing the **EXP GATE** hardware key, and the other one (below right) when pressing \hat{u} (Shift) before the **EXP GATE** key.

Standard View:

'Shift' View:

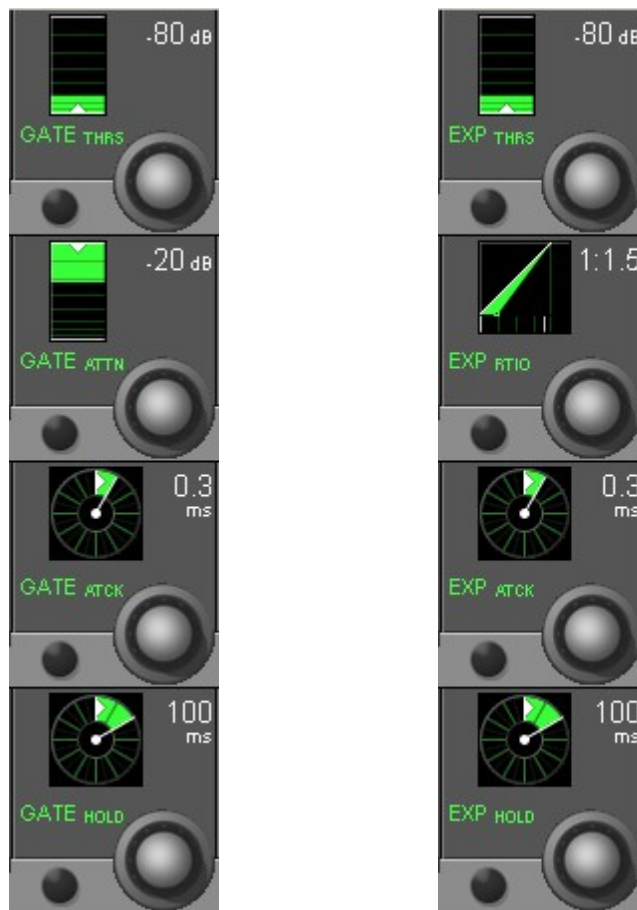

Standard View

- GATE THRS** Rotary The gate threshold level can be adjusted in 1 dB steps from 0 dB_{FS} to -96 dB_{FS}.
- GATE ATTN** Rotary The gate attenuation level can be adjusted in 1 dB steps from 0 dB_{FS} to +60 dB_{FS}.
- GATE ATCK** Rotary The gate attack time can be adjusted in 64 steps within a range of 0.2 ms to 5 ms.
- GATE HOLD** Rotary The gate hold time can be adjusted in 64 steps from 0 ms to 2000 ms.

'Shift' View

- EXP THRS** Rotary The expander threshold level can be adjusted in 1 dB steps from 0 dB_{FS} to -96 dB_{FS}.
- EXP RATIO** Rotary The expander ratio level can be adjusted from 1:1 (no expansion) to 1:40 (heavy expansion).
- EXP ATCK** Rotary The expander attack time can be adjusted in 64 steps within a range of 0.2 ms to 5 ms.
- EXP HOLD** Rotary The expander hold time can be adjusted in 64 steps from 0 ms to 2000 ms .

3.3.9 Parametric EQ

Note Both parametric and graphic EQs may be set up for all or specific channels using the Vista Configuration Editor. Since the graphic EQ uses up all Vistonics controls, there is a channel-related EQ view only, refer to [chapter 3.4.1.2](#).

The two views shown below enable the user to control the *most important* parameters of the parametric EQ section. The *complete* parameter set is available on the channel-related EQ view, refer to [chapter 3.4.1.1](#). There you will also find all parameter details.

All four bands of the parametric EQ section can be activated *simultaneously* with the **EQ** hardware key in the **CHANNEL PROCESSING** section, in addition to the *individual* on/off keys described below.

There are two different views for the parametric EQ view; one of them (below left) is displayed when pressing the **EQ** hardware key, and the other one (below right) when pressing \hat{u} (Shift) before the **EQ** key.

For 5.1 surround channels the parametric equalizer settings are valid for all surround signal legs *except the LFE*. For further information on this subject, please refer to [chapter 3.4.1.1](#).

Standard View:**'Shift' View:**

HI / HM / LM / LO On/Off On/off function for the selected EQ band.

HI / HM / LM / LO GAIN Rotary Boost/cut adjustment; ± 18 dB in steps of 0.5 dB.

HM / LM FREQ Rotary Center frequency adjustment *for the high-mid and low-mid bands*. For both bands, the center frequency can be adjusted from 20 Hz through 20 kHz, in 120 steps. *These controls are visible in the 'shift' view only.*

3.3.10 Panning

Press GLOBAL VIEW: PAN.

This view enables the user to control the *most important* parameters of the panning section. Representation is different depending on channel type (mono/stereo/5.1/stereo upmix), and on the selected panning format. The *complete* parameter set is available on the channel-related pan view, refer to [chapter 3.4.3](#). There you will also find all parameter details.

The panning section can be activated with the PAN hardware key in the CHANNEL PROCESSING section, in addition to the different, individual on/off keys.

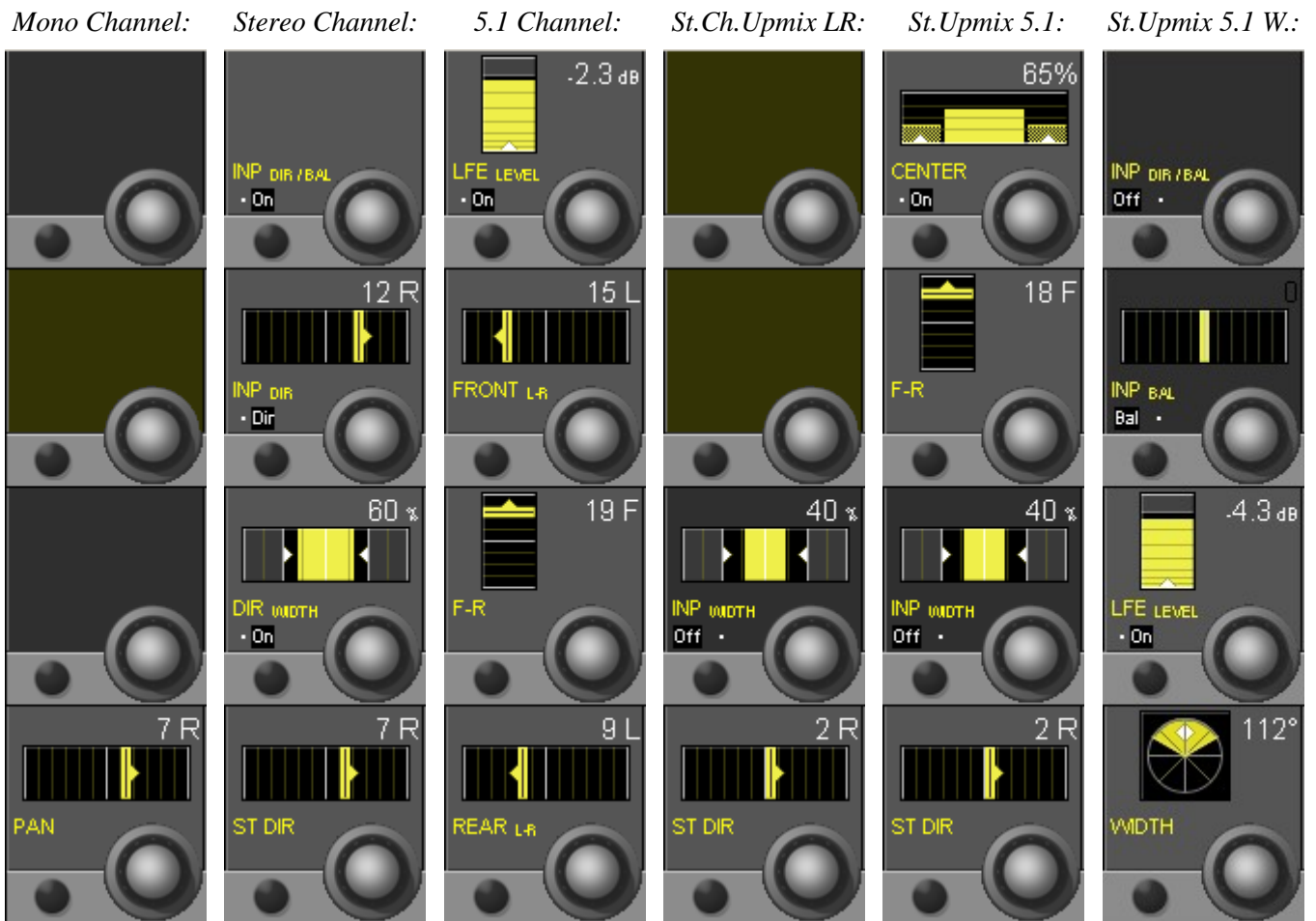

The DIR WIDTH display on stereo channels only appears if this feature has been configured for the corresponding channel.

If a channel is configured with the 'Input Dir/Bal' function, this view also displays the input balance function placed within the input section of the channel.

3.3.11 Global Bus Assignment View

Press **GLOBAL VIEW: BUS ASN** (at the left-hand side of the fader bay). This is an On/Off key that can be activated *in addition* to other global view keys. The bus assignment overview will cover the EQ, dynamics and pan curves on the lower part of the TFT; it disappears when **GLOBAL VIEW: BUS ASN** is pressed again.

The displayed bus assignment bitmap varies depending on the channel type. On a master channel, for instance, no display is activated, since a master channel cannot be routed to a bus. Other channel types may show a part of the bitmap only, depending on possible bus assignments. Therefore the display may show a blank region for some channel types.

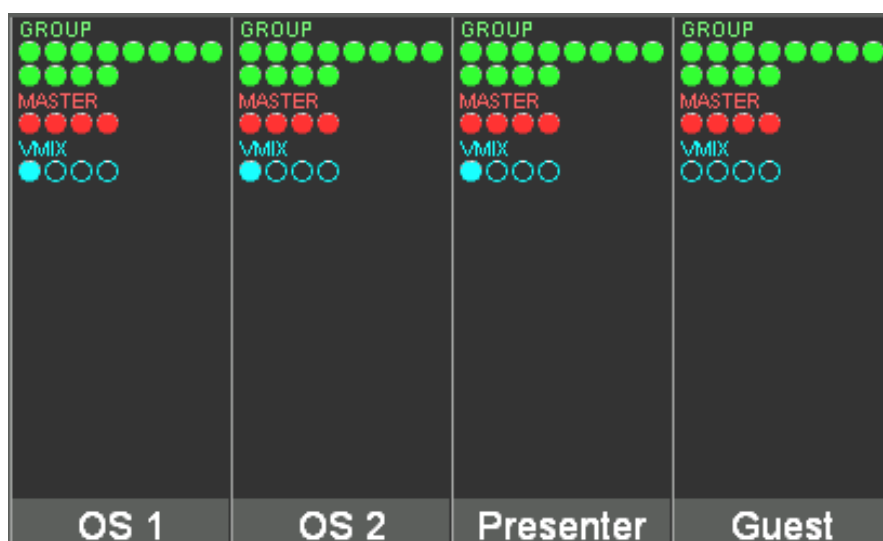

3.3.12 Generic and Label Display Area

Channel label display: The top line always indicates the inherited label (corresponds to the user label of the patched source – ‘track sheet’) of each channel. The second line normally is set to user label display, but can be changed by pressing GLOBAL VIEW: LABEL TYPE.

The channel *type* is indicated with colors in the label display; in addition, the bottom right corner of the label field shows the channel type in writing, as shown below.

| | | | | | | | |
|------------|-------|-------|-------|---------|---------|---------|---------|
| Reverb m 1 | CGM 1 | CGM 2 | CGM 3 | Aux m 1 | Aux m 2 | Aux s 1 | Mst s 1 |
| REVERB | CGM | CGM | CGM | AUX | AUX | AUX | MAST |

Generic Displays, such as **n-1**, **OVER** (fader over-range), etc. are only shown if active:



The numerical fader value is displayed in dB whenever the fader knob is touched; it disappears a short while after the fader knob has been released.



The graphical display of snapshot preview value and current fader value pops up over the right-hand part of the display area, showing the values as bar graphs (current value in gray, snapshot preview value in pink).

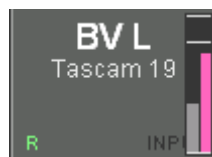

Channels that feed a VistaMix (VMX) bus will show one (mono VMX) or two (stereo VMX) miniature fader symbols in the label area of the Vistonics display that show the gain of the Vistamix function dynamically. Please note that these are *not* audio level meters.



3.4 Channel-Related Views

3.4.1 EQ / Filter

3.4.1.1 Parametric EQ

Note Since SW V4.7 there is an additional 30-band graphic EQ available; both graphic and parametric EQs can be set up either for all or specific channels using the Vista Configuration Editor.

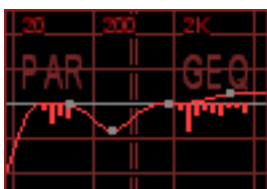

If both EQs are configured within one single channel, the display is split into two different touch areas, showing the combined response of both EQs. It allows unfolding *either* the graphic *or* the parametric EQ parameters of this channel on the Vistonics screen for adjustment. For details of the graphic EQ please refer to the [next chapter](#).

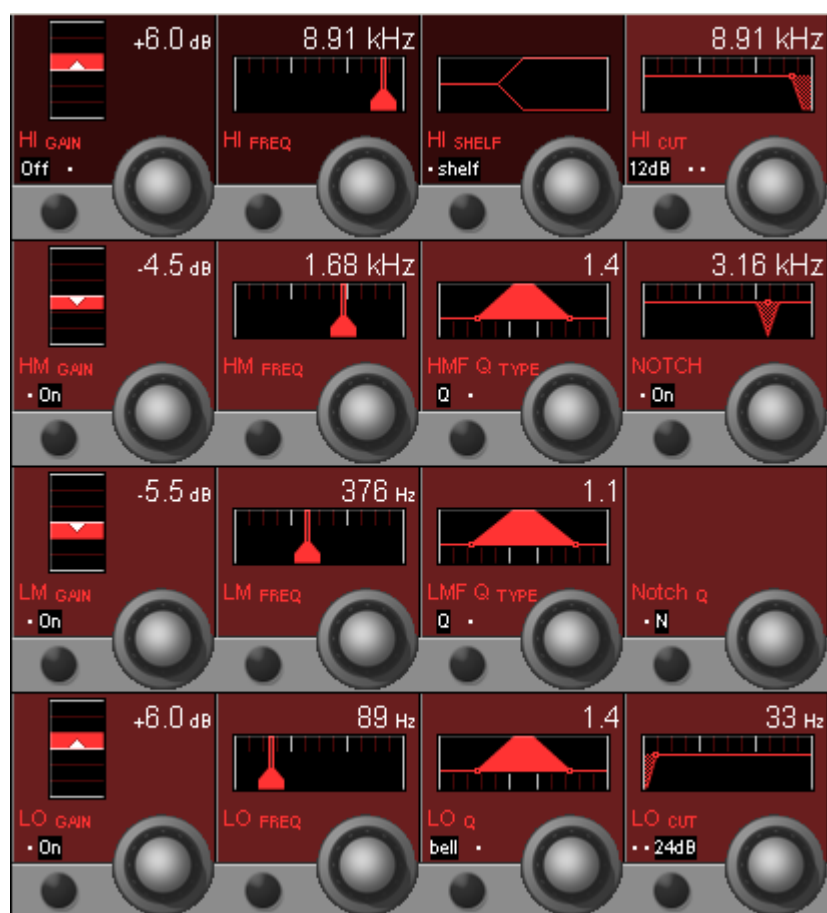

Parametric EQ Parameters:

| | |
|--------------------------------------|---|
| HI / HM / LM / LO On/Off | On/off function for the selected (high, high-mid, low-mid, low) EQ band. |
| HI / HM / LM / LO GAIN Rotary | Boost/cut adjustment; ± 18 dB in steps of 0.5 dB. |
| HI / HM / LM / LO FREQ Rotary | Center frequency (or, if 'shelf' is selected for the HI or LO frequency band: turnover frequency) adjustment. For all four bands, the center/turnover frequency can be adjusted from 20 Hz through 20 kHz, in 120 steps. |
| Q TYPE or bell / shelf | For the HM and LM bands, the Q type can be selected from Q (constant-Q) and R (constant-range) filter types. For the HI and LO bands, bell (same as 'constant-Q' for HM / LM bands) or shelf (shelving-type filter) can be selected. |

Q value Rotary The Q (bandwidth) can be set to values from 0.27 through 8.7, in 30 steps. For the HM and LM bands Q can be set only if 'bell' is selected.
 HM, high-mid frequency, and LM, low-mid frequency: Q = 0.27 through 8.7, in 30 steps.

High-Cut/Low-Cut Filter Parameters:

HI CUT/LO CUT x dB Slope setting for the high- and low-cut filters, selectable from 12, 18, and 24 dB/octave (key toggles 12, 18, 24, 12...).

HI CUT/LO CUT Rotary Cutoff frequency adjustment for the high- and low-cut filter: 20 Hz through 20 kHz, in 120 steps.

Notch Filter Parameters:

Please note that these two fields only appear if the notch filter is configured (i.e., 'EQ with Notch' is selected for this channel in the console configuration).

NOTCH On/Off On/off function for the notch filter.

NOTCH Rotary Center frequency for the notch filter: 20 Hz through 20 kHz, in 120 steps.

Notch Q The notch filter's Q is selectable from two fixed values; W (wide, Q=2), and N (narrow, Q=10).

Note The **EQ**, **HI CUT** and **LO CUT** hardware keys in the **CHANNEL PROCESSING** section can be used for activating or deactivating the complete EQ, high- and low-cut filter sections, in addition to the *individual* on/off keys described above.

5.1 Surround Channels

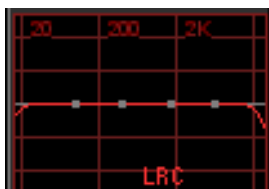

This view is the same as with mono or stereo channels. Please note that the equalizer settings applied here will be valid for all surround signal legs *except for the LFE*.

If an EQ setting has been made on a 5.1 surround channel, the normal Vistonics EQ display shows in small characters which signal legs are different from the others (e.g. 'Lf'), as shown left.

If one or more of the signal legs must be adjusted differently from others – such as boosting HF in the center channel only, the **CHANNEL VIEW** has to be selected. Then all the separate EQ settings for 'Front', 'Center', 'LFE' and 'Rear' are accessible.

3.4.1.2 Graphic EQ

Note Since SW V4.7 there is the additional 30-band graphic EQ available; both graphic and parametric EQs can be set up either for all or specific channels using the Vista Configuration Editor.

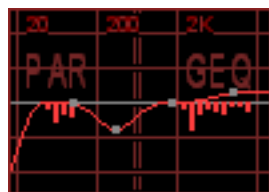

If both EQs are configured within one single channel, the display is split into two different touch areas, showing the combined response of both EQs. It allows unfolding *either* the graphic *or* the parametric EQ parameters of this channel on the Vistonics screen for adjustment. For details of the parametric EQ please refer to the [previous chapter](#).

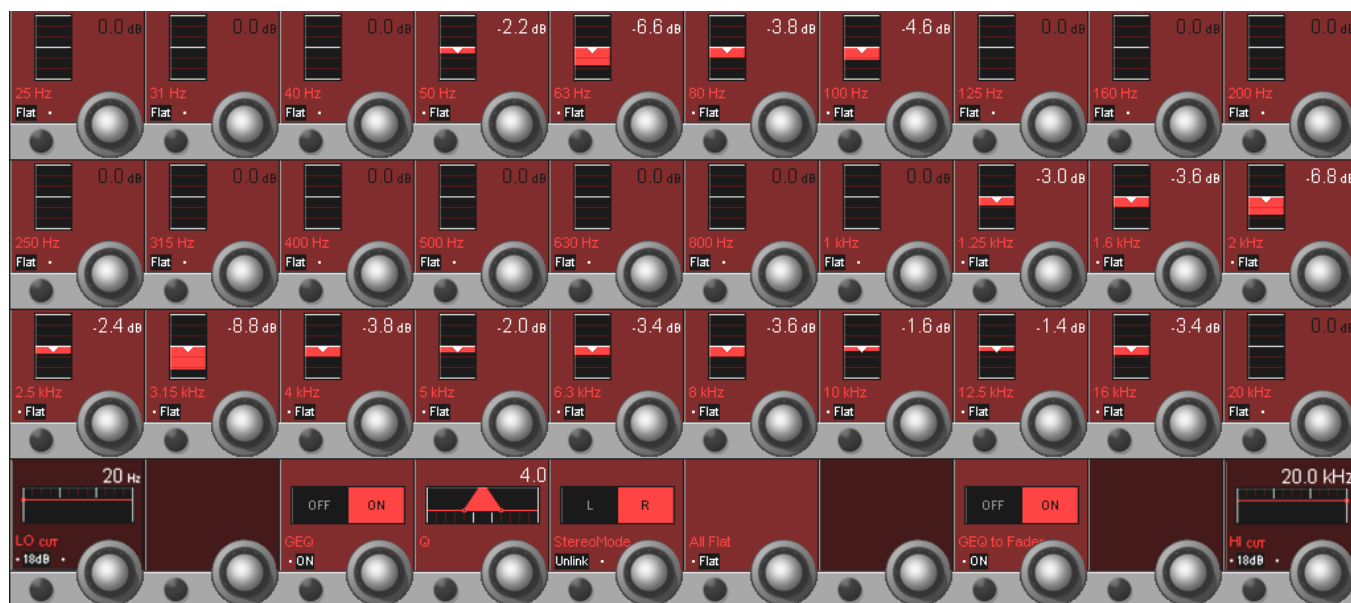

Boost/Cut (Rotary Knobs) The 30 rotary knobs in the three upper rows control boost or cut for the different frequency bands. The individual band center frequencies are fixed and displayed in the corresponding Vistonics fields. Boost/cut can be adjusted in a ± 12 dB range in steps of 0.2 dB.

Flat Every band may individually be set to ‘flat’, i.e., to 0 dB.

LO/HI CUT The low- and high-cut filters are the same as described in the [previous chapter](#).

GEQ OFF/ON Allows bypassing the graphic EQ without changing the settings.

Q Setting of the steepness of all bands in 5 steps between values of 4 and 6.

StereoMode For stereo channels, the graphic EQ can be linked or unlinked for the left and right channels. If ‘Unlink’ is selected, individual settings for L and R can be set; selection between L and R is done with the rotary knob. Default setting is ‘Link’.

All Flat Sets all bands to ‘flat’, i.e., to 0 dB.

GEQ to Faders For ease of operation, the graphic EQ may be switched over to 30 of the console faders for both indication and control the setting. On Vista consoles featuring FaderGlow the colour of the corresponding fader tracks will illuminate in red. The label row of the Vistonics icons changes to center frequency indication, and only the Vistonics EQ icon in the channel strip on which the EQ is active is displayed. All others are blanked to clearly show which channel is affected by the graphic EQ. Any bands set to boost or cut will in addition have their **MUTE** key illuminated in red. Individual bands may be set to ‘flat’ also by pressing their illuminated **MUTE** key.

As soon as any other control except a fader or a channel mute key is touched or operated, fader operation is immediately cancelled and switches back to normal mode.

On Vista consoles with more than 30 faders, the first fader – the one controlling the lowest frequency band of the graphic EQ – is configured in the ‘Vista Settings’ window of the Graphic Controller. This allows the user defining the most convenient position of the EQ faders on the desk.

3.4.2 Dynamics

3.4.2.1 Standard Dynamics

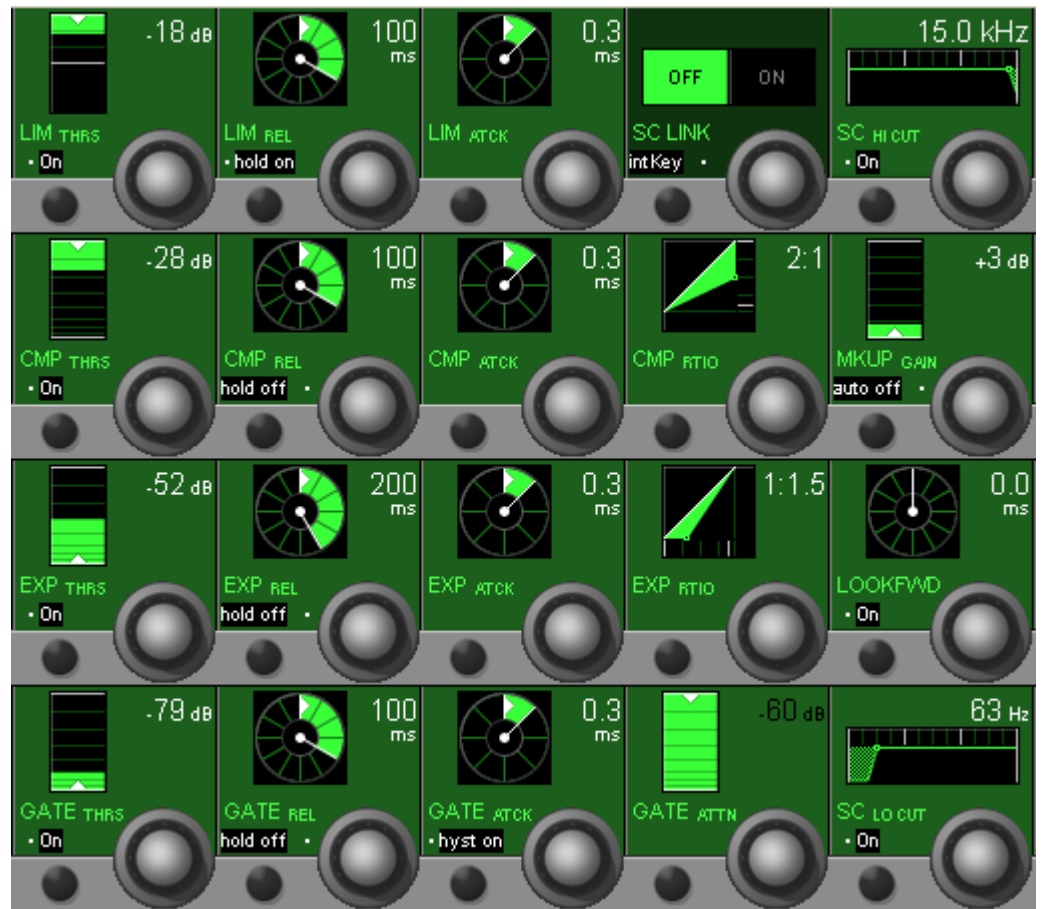

Limiter Parameters:

LIM On/Off Limiter on/off.

LIM THRS Rotary The limiter threshold(=output level) can be adjusted in 1 dB steps from 0 dB_{FS} to -48 dB_{FS}.

LIM REL Rotary The limiter release time can be adjusted in 13 steps within a 10 ms to 10 s range (10 ms, 20 ms, 30 ms, 50 ms, 100 ms, 200 ms, 300 ms, 500 ms, 1 s, 2 s, 3 s, 5 s, and 10 s).

LIM hold on/off Hold on = 150 ms, off = 0 ms.

LIM ATCK Rotary The limiter attack time can be adjusted in 9 steps within a 200 μs to 1 ms range (0.2 ms, 0.3 ms, 0.4 ms, 0.5 ms, 0.6 ms, 0.7 ms, 0.8 ms, 0.9 ms, and 1 ms).

Output level

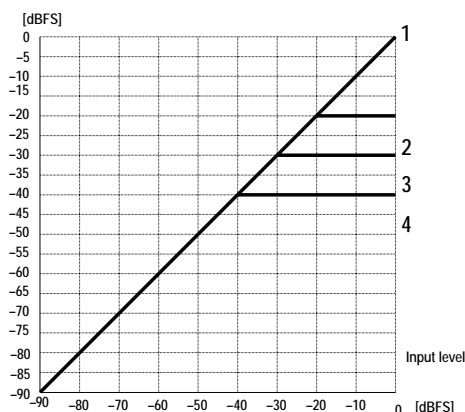

| Curve | Limiter | Threshold [dB] |
|-------|---------|----------------|
| 1 | OFF | Any |
| 1 | ON | 0 |
| 2 | ON | -20 |
| 3 | ON | -30 |
| 4 | ON | -40 |

Compressor Parameters:

- CMP On/Off** Compressor on/off.
- CMP THRS** Rotary The compressor threshold level can be adjusted in 1 dB steps from 0 dB_{FS} to -96 dB_{FS}.
- CMP REL** Rotary The compressor release time can be adjusted in 13 steps within a 10 ms to 10 s range (10 ms, 20 ms, 30 ms, 50 ms, 100 ms, 200 ms, 300 ms, 500 ms, 1 s, 2 s, 3 s, 5 s, and 10 s).
- CMP hold on/off** Hold on = 150 ms, off = 0 ms.
- CMP ATCK** Rotary The compressor attack time can be adjusted in 9 steps within a 200 μs to 20 ms range (0.2 ms, 0.3 ms, 0.5 ms, 1 ms, 2 ms, 3 ms, 5 ms, 10 ms, and 20 ms).
- CMP RTIO** Rotary The compressor ratio can be adjusted from 1:1 (no compression) to 20:1 (heavy compression) in the following steps: 1:1, 5:4, 4:3, 3:2, 5:3, 2:1, 3:1, 5:1, 7:1, 10:1, and 20:1.

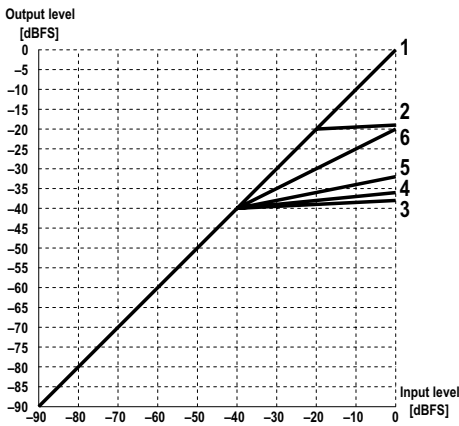

| Curve | Compressor | Threshold [dB] | Ratio |
|-------|------------|----------------|-------|
| 1 | OFF | any | any |
| 1 | ON | 0 | 1:1 |
| 2 | ON | -20 | 20:1 |
| 3 | ON | -40 | 20:1 |
| 4 | ON | -40 | 20:1 |
| 5 | ON | -40 | 5:1 |
| 6 | ON | -40 | 2:1 |

Expander Parameters:

- EXP On/Off** Expander on/off.
- EXP THRS** Rotary The expander threshold level can be adjusted in 1 dB steps from 0 dB_{FS} to -96 dB_{FS}.
- EXP REL** Rotary The expander release time can be adjusted in 13 steps within a 10 ms through 10 s range (10 ms, 20 ms, 30 ms, 50 ms, 100 ms, 200 ms, 300 ms, 500 ms, 1 s, 2 s, 3 s, 5 s, and 10 s).
- EXP hold on/off** Hold on = 150 ms, off = 0 ms.
- EXP ATCK** Rotary The expander attack time can be adjusted in 9 steps within a 200 μs to 1 ms range (0.2 ms, 0.3 ms, 0.4 ms, 0.5 ms, 0.6 ms, 0.7 ms, 0.8 ms, 0.9 ms, and 1 ms).
- EXP RTIO** Rotary The expander ratio can be adjusted from 1:1 (no expansion) to 1:20 (heavy expansion) in the following steps: 1:1, 1:1.3, 1:1.4, 1:1.5, 1:1.7, 1:2, 1:3, 1:5, 1:7, 1:10, and 1:20.

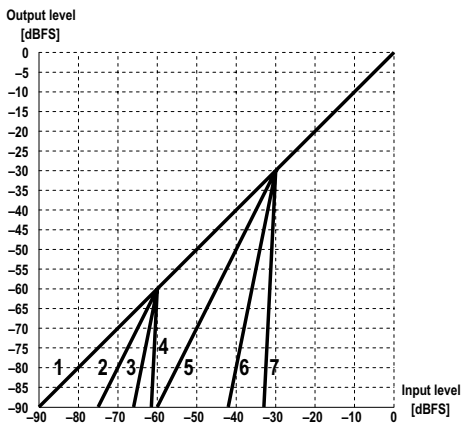

| Curve | Expander | Threshold [dB] | Ratio |
|-------|----------|----------------|-------|
| 1 | OFF | any | any |
| 1 | ON | -96 | any |
| 1 | ON | -30 | 1:1 |
| 2 | ON | -60 | 1:2 |
| 3 | ON | -60 | 1:5 |
| 4 | ON | -60 | 1:20 |
| 5 | ON | -30 | 1:2 |
| 6 | ON | -30 | 1:5 |
| 7 | ON | -30 | 1:20 |

Gate Parameters: GATE On/Off Gate on/off.

GATE THRS Rotary The gate threshold level can be adjusted in 1 dB steps from 0 dB_{FS} to -96 dB_{FS}.

GATE REL Rotary The gate release time can be adjusted in 13 steps within a 10 ms through 10 s range (10 ms, 20 ms, 30 ms, 50 ms, 100 ms, 200 ms, 300 ms, 500 ms, 1 s, 2 s, 3 s, 5 s, and 10 s).

GATE hold on/off Hold on = 150 ms, off = 0 ms.

GATE ATCK Rotary The gate attack time can be adjusted in 9 steps within a 200 μs to 1 ms range (0.2 ms, 0.3 ms, 0.4 ms, 0.5 ms, 0.6 ms, 0.7 ms, 0.8 ms, 0.9 ms, and 1 ms).

GATE hyst on/off The gate hysteresis function provides an offset between the un-mute and mute thresholds. This means the gate will remain open (un-muted) at a lower level than the level than was required to open it. For example, a threshold can be set so that amp noise from an electric guitar will be attenuated as long as the guitar is not played. However, as the guitar sustains and loses energy (level) over time, the gate will remain open at levels below the one that caused it to open in the first place (un-mute threshold). Once the level falls far enough, the gate will close (mute) again.

GATE ATTN Rotary The attenuation level can be adjusted in 1 dB steps from 0 dB_{FS} to -48 dB_{FS}.

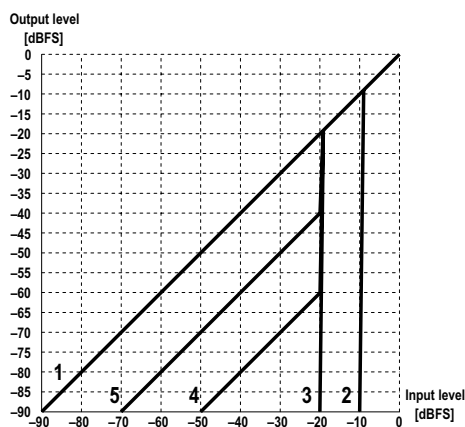

| Curve | Gate | Threshold [dB] | Attenuation [dB] |
|-------|------|----------------|------------------|
| 1 | OFF | any | any |
| 1 | ON | 0 | 0 |
| 2 | ON | -10 | max. |
| 3 | ON | -20 | max. |
| 4 | ON | -20 | -40 |
| 5 | ON | -20 | -20 |

Parameters Shared by all Dynamics Functions:

SC LINK Rotary The Side-Chain Link function allows forming a side-chain group from up to eight channels in order to control the dynamics of all of them by the highest of all side-chain group member levels (‘one to control them all’). Side-chains are defined in the GC’s Channel Patch window. The rotary encoder switches the side-chain link function on/off, if it is available for the specified channel.

SC LINK intKey/extKey The key source input can be selected from intKey (dynamics processing depends on the channel’s input signal), or extKey (processing is controlled by a signal connected via the patch).

SC HI CUT/LO CUT On/Off High- and low-cut filters are available within the side-chain key signal. This facilitates frequency-dependent dynamic processing for creating effects, such as de-essing. Both side-chain filters can be switched on/off independently.

- SC HI CUT/LO CUT** Rotary Both side-chain high- and low-cut filters feature cut-off frequencies continuously adjustable between 20 Hz and 20 kHz.
- MKUP GAIN auto on/off** **auto on** automatically compensates a compressor level loss. **auto off** activates the manual **MKUP GAIN** rotary control.
- MKUP GAIN** Rotary To manually compensate a level loss caused by the dynamics processing, adjustable in 1 dB steps from 0 through +24 dB.
- LOOKFWD On/Off** The Look-Forward Delay function allows inserting an audio delay after the dynamics level detector in order to work with higher attack times without any overshooting of levels.
- LOOKFWD** Rotary The Look-Forward Delay can be set in 11 steps within a range from 0 to 25 ms (0 ms, 0.2 ms, 0.3 ms, 0.5 ms, 1 ms, 2 ms, 3 ms, 5 ms, 10 ms, 20 ms, and 25 ms).
By activating the look-forward feature, a real delay is inserted into the audio path. In order to avoid artifacts with other console channels, it is recommended to insert a corresponding delay into the other channels as well.
- Note** There are **COMP/LIMIT** and **EXP/GATE** hardware keys in the **CHANNEL PROCESSING** section for activating/deactivating the compressor/limiter and expander/gate parts of the dynamics section, in addition to the individual on/off keys for the dynamics functions.

3.4.2.2 Standard Dynamics for 5.1 Surround Channels

Touch the green Vistonics dynamics field.

This view is the same as with mono or stereo channels with one exception, refer to the screenshot below. *Please note that the dynamics settings applied here will be valid for all surround signal legs except the LFE.*

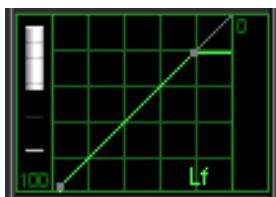
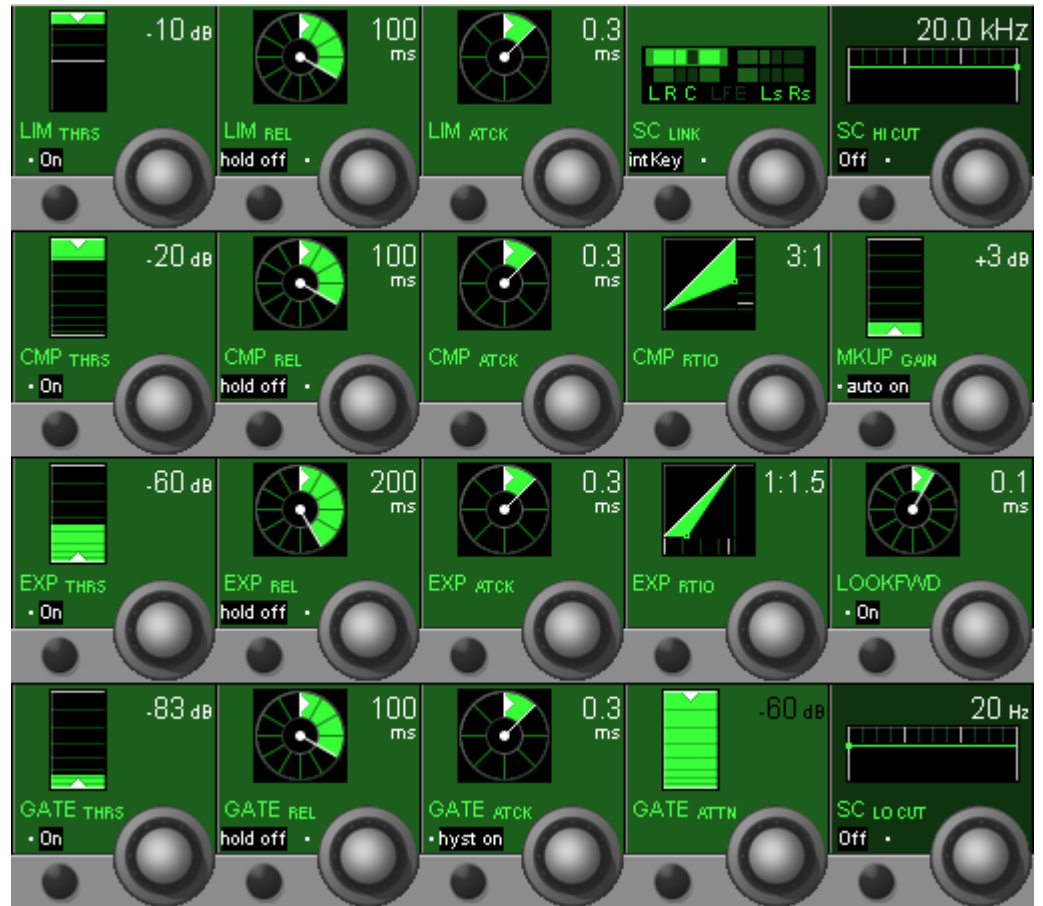

If a dynamics setting has been made on a 5.1 surround channel, the default Vistonics dynamics display shows in small characters which signal leg is different from the others (in this case, only 'Lf' is shown since the LFE's EQ setting is not modified), as shown left.

If one or more of the signal legs must be adjusted differently from others – such as adding expansion in the center channel only, the CHANNEL VIEW has to be selected. Then all the separate dynamics settings for 'Front', 'Center', 'LFE' and 'Rear' are accessible. Please note that there also is a gain reduction indication at the left of each of the four individual dynamics icons.

Parameters Shared by the Dynamics Functions

SC LINK

The Side-Chain Link function allows forming a side-chain group from up to eight channels in order to control the dynamics of all of them by the maximum level of all side-chain group members. Side-chains are defined in the GC's Channel Patch window ('Sidechain Link Setup', tick 'Enable side Chain Link'). The rotary encoder selects the surround signal legs used for the side-chain group; for details, see the block diagram below.



Four different possibilities are available:

All signal legs (L, R, C, Ls, Rs) are part of the sidechain link.

Only the L, R, Ls and Rs signal legs are part of the sidechain link.

Only the L, R and C signal legs are part of the sidechain link.

Only the L and R signal legs are part of the sidechain link.

SC LINK intKey/extKey

The key source input can be selected from intKey (dynamics processing depends on the channel's own input signal, i.e. an internal key signal), or extKey (processing is controlled by a signal connected via the patch, i.e. by an external key signal).

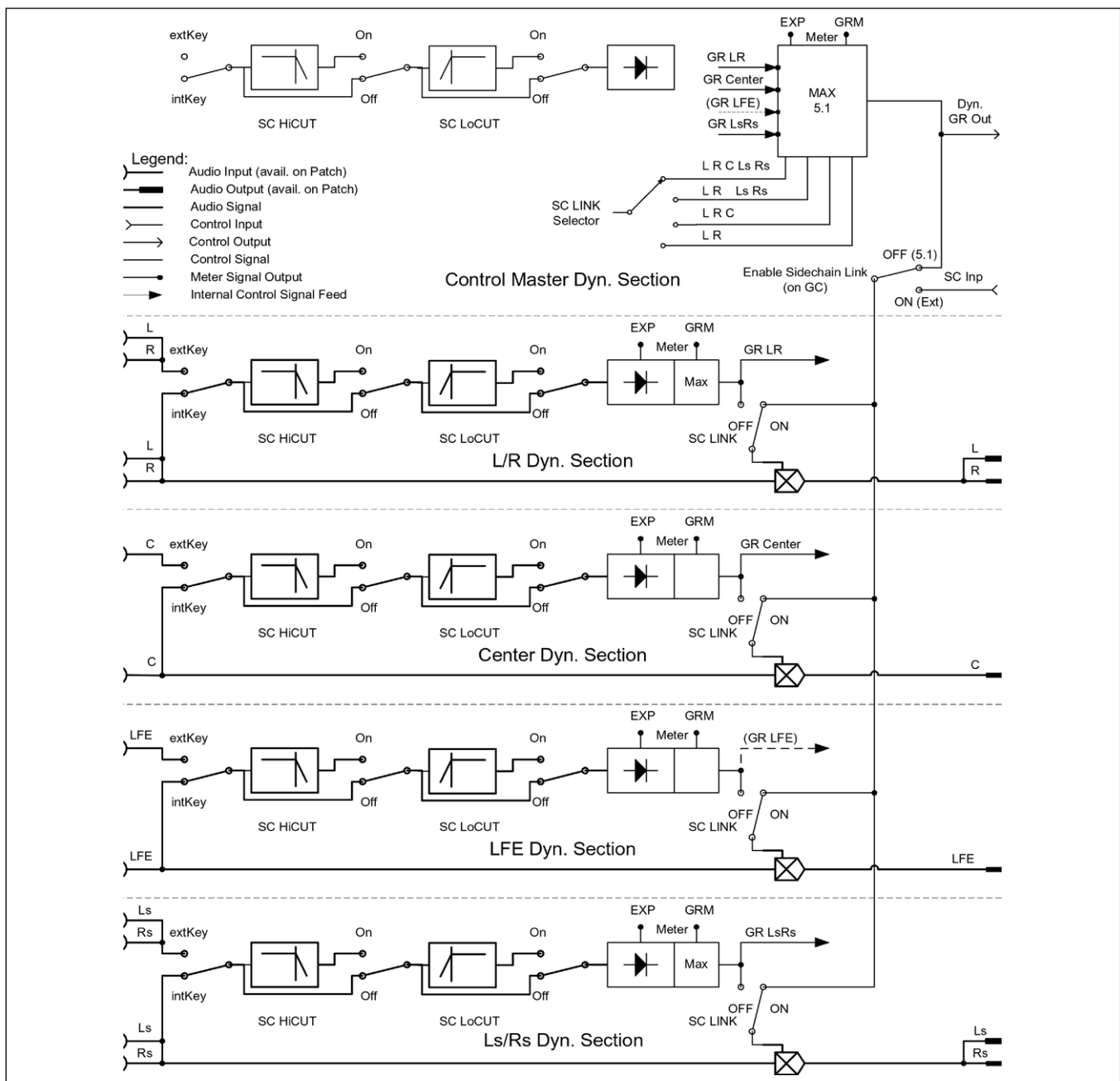

3.4.2.3 Vintage Dynamics

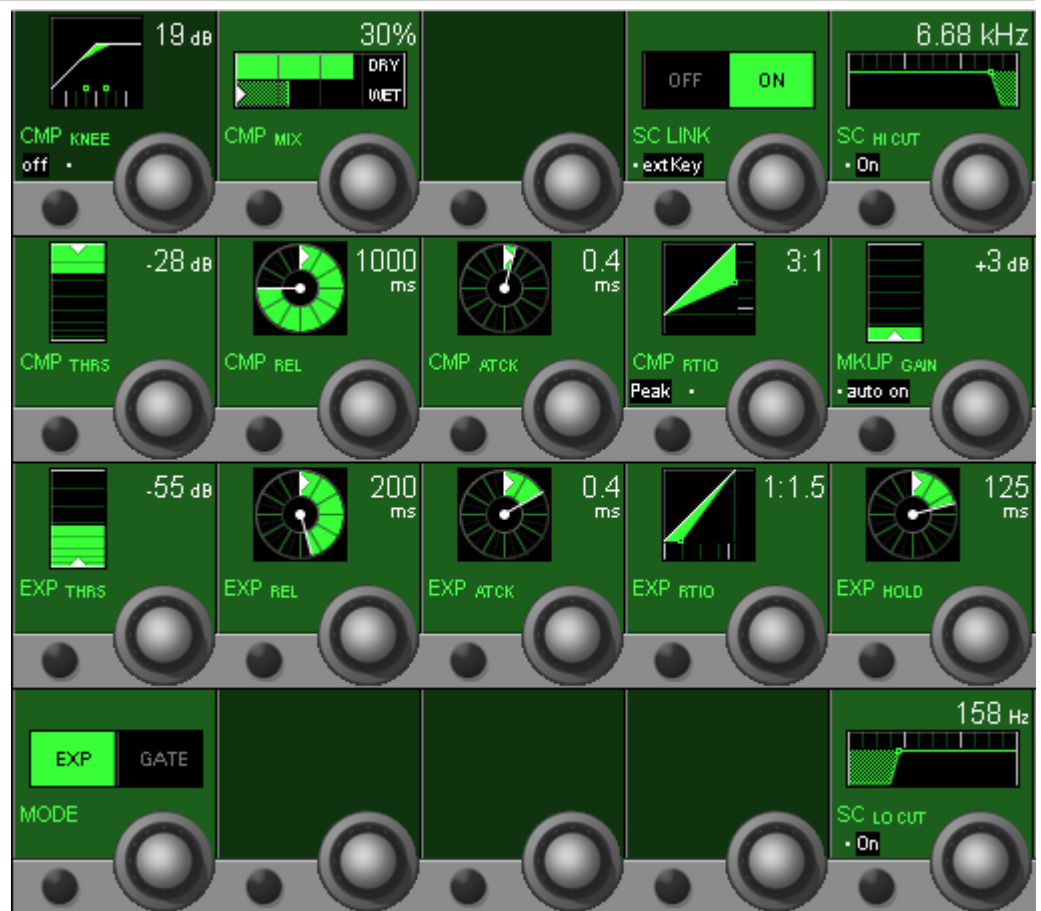

The main differences between the vintage and standard dynamics sections is that the vintage dynamics are intended to be used as an effect by itself rather than being transparent. Its compressor has some additional parameters compared with the standard dynamics section, but no hold function instead; there is no limiter available, and the expander and gate sections cannot be used at the same time.

Below, only the parameters different from the ones of the standard dynamics section are described.

Vintage Compressor Parameters:

CMP KNEE Rotary The smooth transition ('soft knee') at the compressor threshold can be adjusted, the window size can be set between 0 and 60 dB.

CMP KNEE on/off Switches the compressor's 'soft knee' on or off.

CMP MIX Rotary If the **CMP MIX** function is on, this parameter allows mixing or blending of the dry (original) and the wet (compressed) signals. 0% setting: dry signal only; 100% setting: wet signal only.

CMP MIX on/off 'on' activates the **CMP MIX** function; 'off' selects the compressed signal only.

When the **CMP MIX** function is set to 'on', the ratio of the dry (original) to the wet (compressed) signal depends on the selected mix ratio. In other words, mixing between the original and the compressed signals is possible.

| | |
|-------------------------------|---|
| CMP REL Rotary | The compressor release time can be adjusted within a 5 ms to 5 s range. |
| CMP ATCK Rotary | The compressor attack time can be adjusted in steps within a 200 μ s through 250 ms range. |
| CMP RTIO Rotary | The compressor ratio can be adjusted from 1:1 (no compression) through 40:1 (very heavy compression). |
| EXP / GATE MODE Rotary | Used for selecting <i>either</i> the expander <i>or</i> the gate function for the vintage dynamics section. <i>The threshold, release, attack and hold parameters of expander and gate are adjusted in common; they cannot be set individually.</i> |
| EXP / GATE REL Rotary | The expander/gate release time can be adjusted within a 5 ms through 5 s range. |
| EXP / GATE ATCK Rotary | The expander / gate attack time can be adjusted within a 0.5 through 5 ms range. |
| EXP RTIO Rotary | The expander ratio can be adjusted from 1:1 (no expansion) through 1:40 (very heavy expansion). |
| EXP / GATE hold Rotary | The expander / gate hold time can be adjusted within a 0 through 2 s range. |

3.4.3 Panning

There are several panning options available. These range from a simple mono-to-left/right pan over a stereo direction pan with width control to the sophisticated family of *Virtual Surround Panning* (VSP) modules. Left/Right and VSP functions are available for mono input, group, multi-track input, and multi-track monitor channels. Direction and Direction with Width functions are available for stereo input and group channels. In addition, there exist upmix panning functions for easily inserting stereo sources into surround mixes.

The panning functions can be controlled by the Vista's motorized joystick. To assign a channel to the joystick, press the joystick **FOLLOW** key (it will light) and then the **LINK/SEL** key for the desired channel. The joystick can be used to automate panning functions and then be reassigned to another channel by pressing the **LINK/SEL** key of this channel.

Please note that there are **PAN** hardware keys above the Vistonics screens for activating or deactivating the complete panning section, in addition to the individual On/Off keys for the panning parameters.

If the **PAN** keys are de-activated, the channel signals are directly fed to all assigned buses, without being influenced by any panning.

LR PAN for Mono Channels

The LR panning function is a simple PAN potentiometer controlling the contribution of the mono signal to the odd and even or left and right buses.

- PAN ON/OFF
- PAN function: Mono direction in 1° steps from -30° (L) to +30° (R).

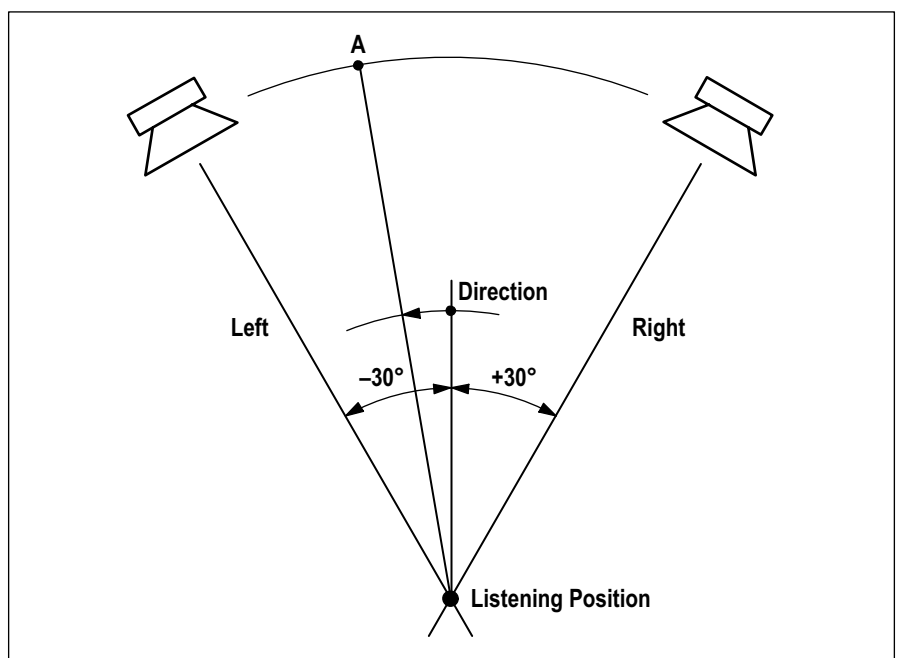

LR PAN for Stereo Channels

The PAN ON/OFF and PAN functions are extended to enable working with either standard (L/R) stereo or with MS (mono/side) signals. In addition, features are available to increase the stereo image manipulation possibilities, such as

- Input direction or
- Input balance,
- Stereo width (pan width), and
- Stereo direction.

The stereo width function has to be activated with the Session Configuration Tool, if required.

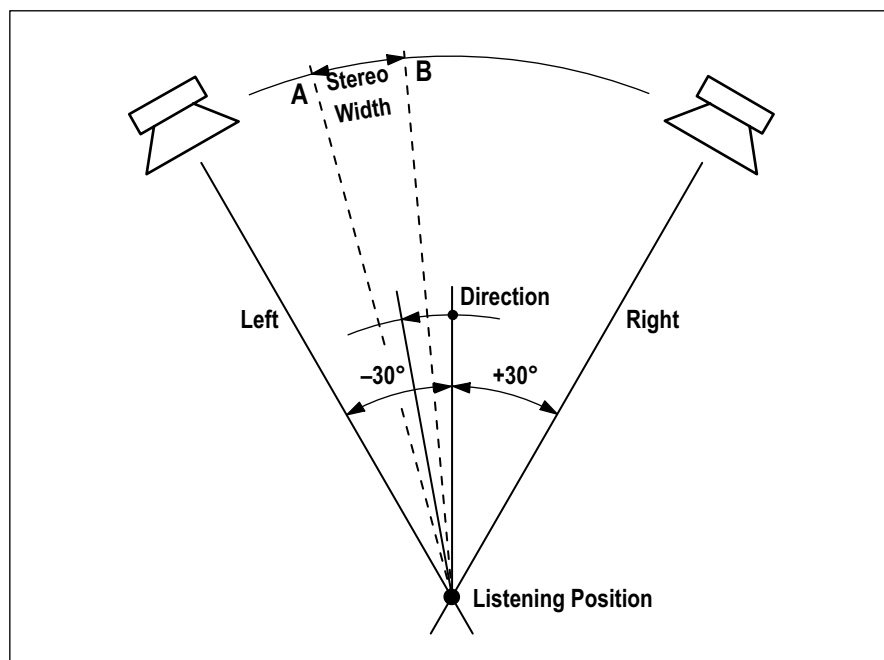

Virtual Surround Panning (VSP)

Various surround panning algorithms can be configured for mono input, group, multi-track input, and multi-track monitor channels using the Session Configuration Tool.

Basically, two different surround panning algorithms are available: Multi-format pan, and VSP (Virtual Surround Panning), see table; some more information on these algorithms is given in the ‘Parameters’ sections below.

| Algorithm: | Format 2-CH to 7.1-CH | LCR, F/B, Ls/Rs Pan | Divergence | Seamless Center Channel Usage | Pan Mode | VSP Controls: Ambience, Distance, Absorption, Room Size |
|------------------|-----------------------|---------------------|------------|-------------------------------|-----------------------------------|---|
| Multi-Format Pan | X | X | X | X | Amplitude | - |
| VSP Pan | X | X | X | X | Amplitude, HRTF, Sphere, ORTF, AB | X |

Depending upon the currently loaded session configuration, one or both algorithms above may be present in the console at a time.

3.4.3.1 Amplitude Panning

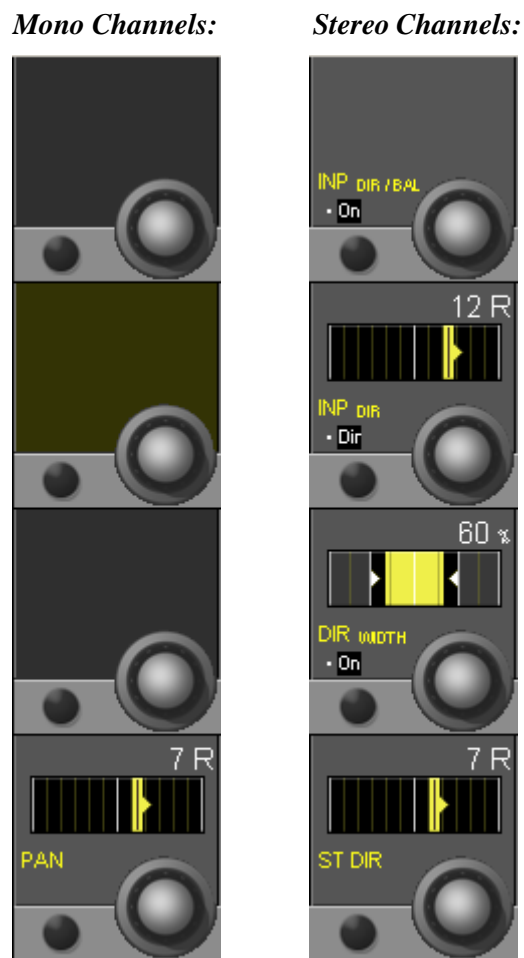
**LR Panning Parameters for Mono Channels:**

Mono channel LR PAN has only one panning function: left/right panning. It is useful for left/right panning to stereo master or group buses, or for odd/even panning to group or multi-track buses.

General PAN On/Off is selected with the **PAN** hardware key in the **CHANNEL PROCESSING** section.

PAN Rotary The rotary encoder provides left/right (odd/even) panning control in 1° steps from -30° (fully left) to +30° (fully right).

LR/Direction Panning Parameters for Stereo Channels:

Stereo channel DIR/BAL PAN is a stereo direction panning function. It is useful for controlling the direction of stereo signals to master, group, and multi-track buses.

DIR WIDTH is identical to the DIR pan with an optional width control added (depending on the current session configuration).

PAN On/Off is selected with the **PAN** hardware key in the **CHANNEL PROCESSING** section.

INP DIR / BAL On/Off Activates the input balance or the input direction control, depending on the function selected with INP BAL / INP DIR. This function is placed within the signal path of the channel *before* the mono switch, selectable in the '2CH mode' section.

INP DIR / BAL Selection from two input functions: INP BAL *or* INP DIR.

INP DIR / INP BAL Rotary The INP DIR function is used to control the *direction* of a stereo input signal. Turning the rotary encoder shifts the input direction in 1° steps from -30° (left) to +30° (right).
The INP BAL function is used to control the *balance* of a stereo input signal. Turning the rotary encoder to the left attenuates the right channel from 0 to -∞ dB while the left channel remains at full input level, and vice versa.

DIR WIDTH On/Off *Optional, only if the width function is configured.*
Switches the DIR WIDTH function on/off.

DIR WIDTH Rotary *Optional, only if the width function is configured.*
The DIR WIDTH parameter is used to control the width of the stereo signal. It is only functional if there is a difference between the left and right input channels, or if IBAL or IDIR has been used to create an offset between the channels. The ST DIR control directs the position of the stereo signal, while the DIR WIDTH control determines the *width* or *stereo spread* either side of that position. DIR WIDTH operates over a range from 0% (mono) to 200% ('super stereo').

ST DIR Rotary Left/right (or odd/even) panning control for a stereo output signal in 1° steps from -30° (fully left) to +30° (fully right).

3.4.3.2 Upmix Panner (for Stereo Channels only)

Still a significant number of stereo sources is used for a typical surround production, so these need to be brought into the 5.1-channel format. The *upmix panner* is a way to pan stereo signals to a surround mix, providing the possibility to ‘unwrap’ a simple stereo signal to a surround sound field. Every stereo channel can be equipped with the upmix panner. There are three operating modes: ‘Normal LR’, ‘5.1’, and ‘5.1 width’ modes. ‘LR’ mode is normal stereo panning; ‘5.1’ mode uses ‘standard’ amplitude panning, where e.g. the left channel is sent to the left surround speaker, etc. The most uncommon of these modes is ‘5.1 width’.

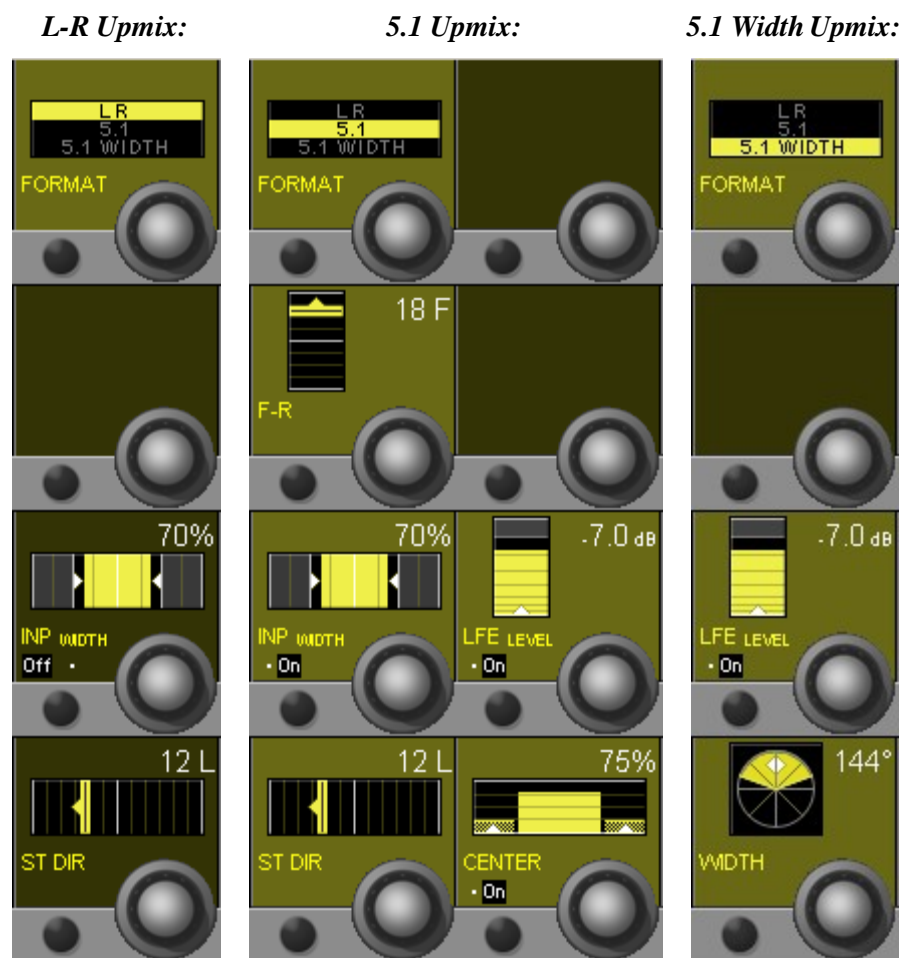

FORMAT Selector for the upmix panning mode.

The remaining parameters are the same as described in the chapters before, with one exception:

WIDTH In 5.1 WIDTH mode. This is a special algorithm (using Harman corporate intellectual property), extending the stereo width control to the rear channels as well.

3.4.3.3 Multi-Format Panning

Surround panning consists of two panning algorithms: Multi-format panning, and VSP (Virtual Surround Panning). These support a variety of surround formats and applications; in all these modes, an LFE (Low Frequency Effects) control is available. *Multi-format panning functions can be configured only for mono channel types.*

Please note that the view below shows 5.1 panning format; for other panning formats, one or more of the fields may be blanked.

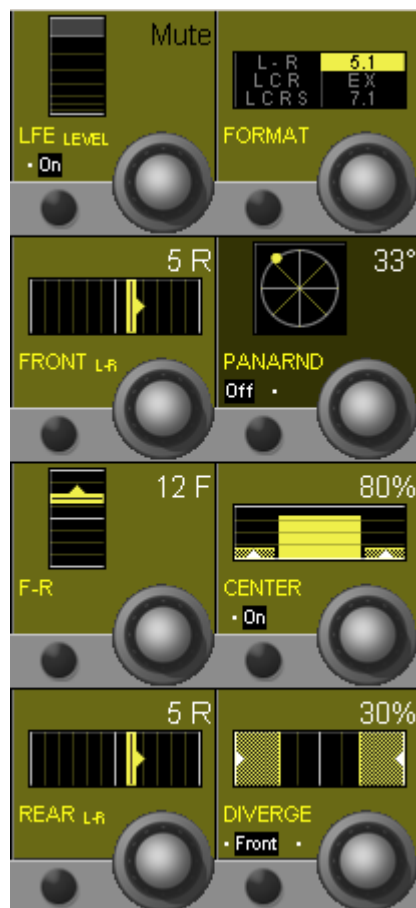

General **PAN** On/Off is selected with the **PAN** hardware key in the **CHANNEL PROCESSING** section.

LFE On/Off On/off control for the LFE (Low Frequency Effects) channel.

LFE LEVEL Rotary LFE level control from MUTE (i.e. $-\infty$ dB) to +10 dB.
Within this section, no filtering is applied to the signal fed to the LFE bus.

FRONT L-R Rotary This parameter controls the front panning between the left, (left-center, center, right-center), and right channels in 1° steps. The contribution to the center channel is determined by the CENTER rotary control.

F-R Rotary This front/rear parameter provides panning between front channels (LCR) and the rear channels (left and right surround) in 60 increments.

REAR L-R Rotary This parameter controls panning between the left and right surround channels.

- FORMAT** Rotary This serves as the format selector in all multi-format panning modes. The following selections are possible: L-R, LCR, LCRS, 5.1, EX, and 7.1. *Depending on this selection, the actually required parameters are displayed.*
- PANARND On/Off** This key activates the unique Pan-Around function. *If active, the FRONT L-R, F-R and REAR L-R controls become inactive.*
- PANARND** Rotary This is a single-knob function that provides an easy-to-use pan setting around all selected loudspeakers (depending on format) in a circular fashion. *If active, the FRONT L-R, F-R and REAR L-R controls become inactive.*
- CENTER On/Off** On/off selector for center channel use.
- CENTER** Rotary Center channel percentage control; 0% = no center channel use (phantom center), 100% = center channel fully active.
- DIVERGE Off/Front/All** Divergence mode selector. The divergence function can be applied to panning between all channels or the front channels only. The key toggles between off, front and all.
- DIVERGE** Rotary The divergence function is used to bleed portions of sound from the panned output to the other speakers. For example, if the divergence is active and set to 100%, the LR control will act as a traditional L/R pan pot (assuming there is no center channel contribution). Panning to full left will result in full attenuation of the right channel. If the divergence is then set to 50%, one half of the left channel signal strength will be *bled* into the right channel (without effecting the left channel). With the divergence control set to 1%, equal signal will be fed to both channels and the LR pan pot will have no effect. Divergence values are as follows: 1%, 2%, 3%, 4%, 5%, 10%, 15%, 20%, 25%, 30%, 35%, 40%, 45%, 50%, 60%, 70%, 80%, 90%, 100%. Careful use of this control may have the effect of increasing the size of the mix 'sweet spot', particularly for large auditoria. Misuse of this control may result in essentially mono panning.

3.4.3.4 VSP Panning

Please note that the controls within the left part of the screenshot below are identical with the ones in [chapter 3.4.3.2](#) – for details, please refer to the description in that chapter.

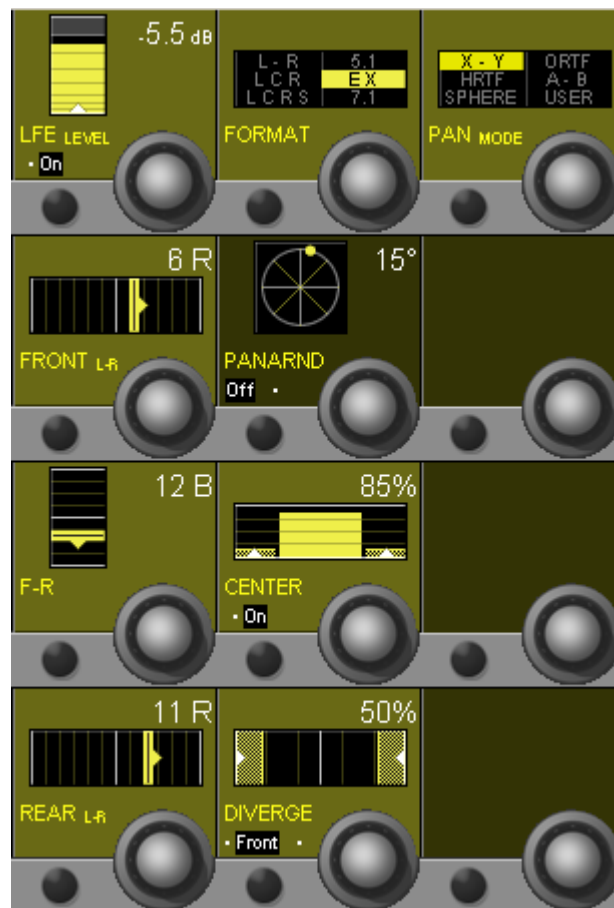

PAN MODE Rotary Sets the overall panning algorithm used for positioning the mono source in the desired virtual location. In all but the X-Y mode, a stereo microphone simulation is employed which will yield a more diverse sound field.

- **X-Y** – A standard panning algorithm that only changes the amplitude of the signal to the various buses in relation to the position of the panner. This operation is well known and is used in all conventional panners.
- **HRTF** – Mainly a cross-talk canceler using simplified HRTFs (Head Related Transfer Functions). If the listener is positioned exactly in the sweet spot of a $\pm 30^\circ$ speaker setup, an extreme panning position like full left should affect the signal such that it will only be heard with the left ear and cancelled out on the right. It may also be used for enlarging the perceived width of a recording.
- **SPHERE** – This mode emulates a spherical microphone as shown in [chapter 3.4.3.6](#). The spherical microphone has two capsules mounted into a sphere having a diameter of about 18 cm. The sphere incorporates different effects on the two channels, including amplitude, delay and shadowing of the high frequencies on the channel which is not facing the source. This mode is only useful in two-channel mode, and presents a very accurate sound field.

- **ORTF** – An idealized version of the common cardioid microphone setup according to angles and distances used for stereo miking. A more accurate sound field is created through the manipulation of both amplitude and time differences.
- **A-B** – An idealized version of the common setup using omni-directional microphones. With this mode the sound stage is perceived as large, and is useful for solo instruments, audience, and choir. The positioning of the source is only established by changes in time delays.
- **USER** – When this mode is selected, the panning algorithms are established from the Microphone User Settings interface provided under the main Option menu in the system Graphical Controller. The settings made affect the relationship between amplitude and time differences, determined by the settings of the imaginary microphones. For details, see [chapter 3.4.3.6](#).

3.4.3.5 Panning for 5.1 Surround Channels

Touch the yellow Vistronics pan field.

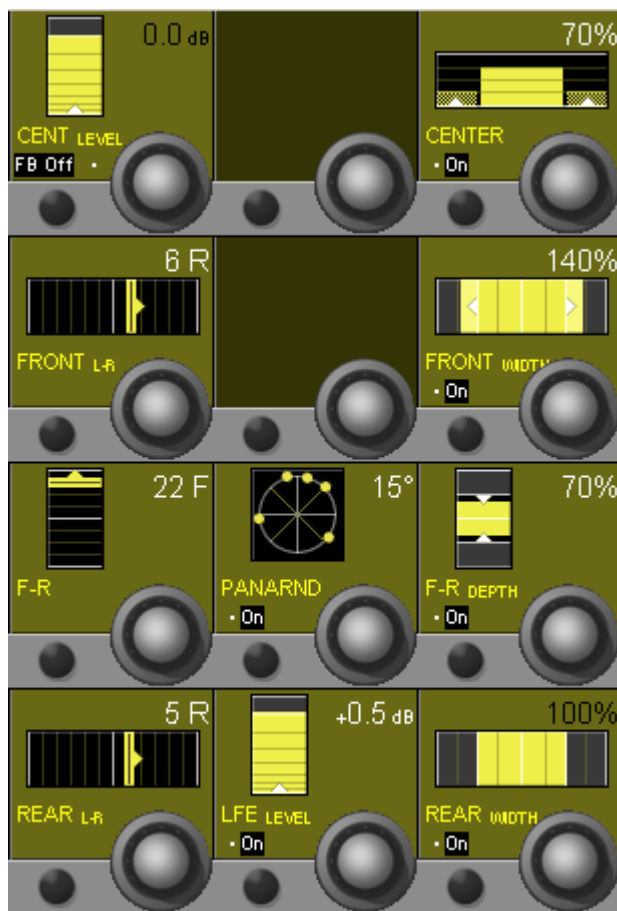

General PAN On/Off is selected with the PAN hardware key in the CHANNEL PROCESSING section.

CENT LEVEL Center level control from MUTE (i.e. $-\infty$ dB) to +10 dB.

FB On/Off On/off switch for center channel contribution to the F-R control.

FRONT L-R Front panning between the left, (center) and right channels in 1° steps. The contribution to the center channel is determined by the CENTER control.

F-R This parameter allows variable blending from front to rear channels in 60 increments, either with a contribution from the center channel (FB On) or without (FB Off).

REAR L-R Panning between the left and right surround channels in 1° steps.

PANARND On/Off Activates the Pan-Around function.

PANARND Single-knob function, allows rotating the surround sound field by $\pm 180^\circ$.

LFE On/Off On/off selector for LFE channel use.

LFE LEVEL LFE channel percentage control; 0% = no LFE channel use, 100% = LFE channel fully active.

- CENTER On/Off** On/off selector for center channel use.
- CENTER** Center channel percentage control; 0% = no center channel use (phantom center), 100% = center channel fully active.
- FRONT WIDTH On/Off** Switches the FRONT WIDTH function on/off.
- FRONT WIDTH** The FRONT WIDTH parameter is used to control the width of the front signal. It is only functional if there is a difference between the left and right input channels. FRONT WIDTH operates over a range from 0% (mono) to 200% ('super stereo').
- F/R DEPTH On/Off** Switches the F/R DEPTH function on/off.
- F/R DEPTH** The F/R DEPTH parameter is used to control the depth of the surround space. It is only functional if there is a difference between the front and the rear input channels. F/R DEPTH operates over a range from 0% (zero depth) to 200% ('super depth').
- REAR WIDTH On/Off** Switches the REAR WIDTH function on/off.
- REAR WIDTH** The REAR WIDTH parameter is used to control the width of the rear signal. It is only functional if there is a difference between the left and right input channels. REAR WIDTH operates over a range from 0% (mono) to 200% ('super stereo').

3.4.3.6 Microphone Simulation Tool (MST) – User Pan Mode

As a further sophistication of the VSP system, a Microphone Simulation Tool (MST) has been created. This allows the mix engineer to create his/her own multi-channel panning law, by simulating the placement of microphones in a virtual space.

Overview

A user can define how the VSP varies the delays and amplitudes of the direct sound when panning between speakers. To instruct the VSP how to generate these signals, commonly known microphone symbols are used. Each symbol represents the signal that will be sent to one speaker.

For example, if five omni microphones are set up at the same position, no panning effect will be achieved. Five omni microphones at certain distances will only create time differences when panning between speakers. Five shotgun microphones positioned in one location will only generate amplitude differences. And five directional microphones positioned in different locations will generate both amplitude and time differences between the speakers (based on the placement of the ‘microphones’).

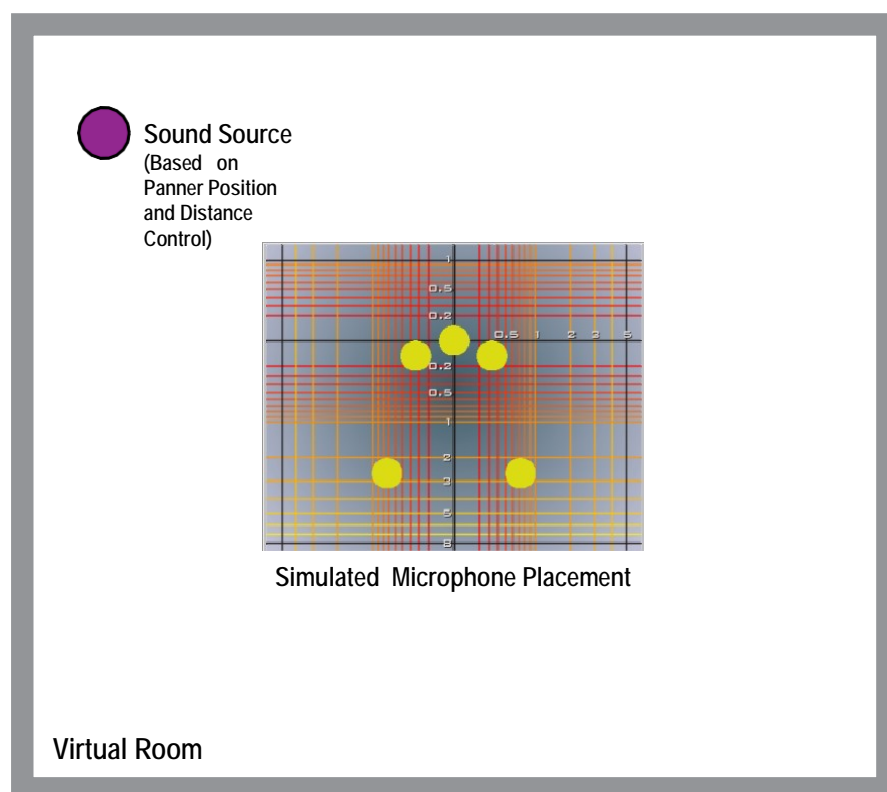

The dry signal within a VSP channel is now placed to an imaginary position based on the panner positioning within the channel. You can now imagine that, if each speaker (in your monitoring environment) is fed the signal based on the placement of the ‘microphones’ in the simulation (including the reflections), that a realistic sound space could be achieved. This is a simplification of what happens within the VSP system.

Each of the Panner modes (ORTF, AMP, AB, etc.) simulates a different placement of the microphones, and therefore yields a different acoustic scene.

Here are the placements for some of the Panner Mode presets:

ORTF (With Surrounds)

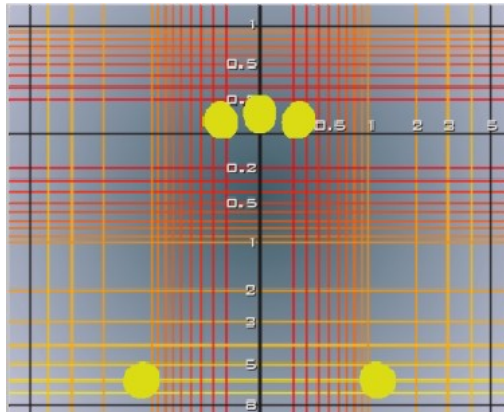

The amplitudes vary due to the directionality of the microphones, while time delay is varied based on the distances between the microphones (each of them feeding a speaker).

AB (With Surrounds)

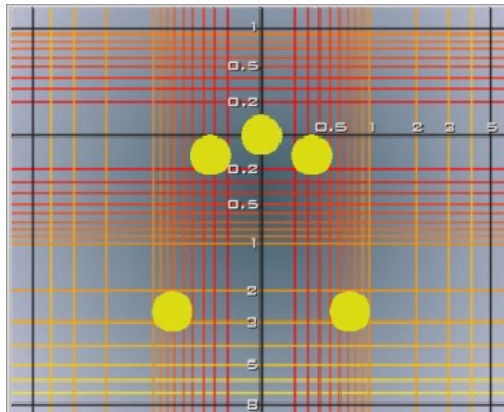

Because all microphones are omni-directional, the amplitude is the same for all of them, but the delay differs due to the distances between the microphones.

Sphere

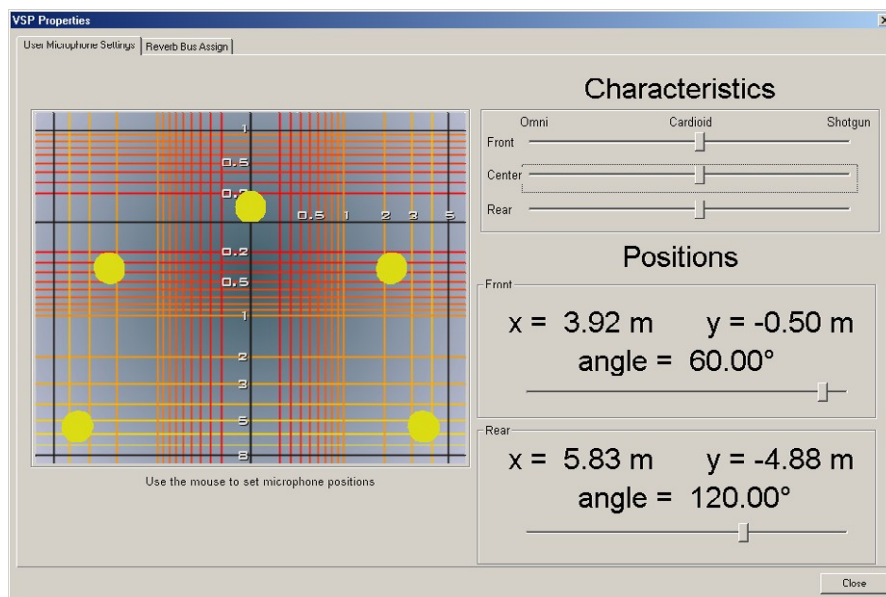

The Sphere setting is based on a microphone as shown in the picture above. Amplitude, phase and frequency response is calculated based on measured signals from such a microphone.

User Setting

With the Microphone Simulation Tool, the mix engineer is able to set up his/her own microphone simulation using the dialog box available in the Options/VSP menu.

Microphone Positioning

The settings may be changed as follows:

The front left and right microphones may be moved by grabbing one of them with the trackball and positioning it as desired. The opposite microphone moves to a symmetrical location. The same may be done with the rear left and right microphones. The center microphone cannot be moved.

Microphone Pattern

The front, center, and rear microphones may be independently changed as to their polar characteristics. This may be done using the sliders. Each pattern can be changed from omni-directional to shotgun.

Microphone Angle

The Front and Rear microphones may also be independently changed as to their positioning angle. This may be done using the angle sliders, or by double-clicking and dragging with the mouse.

So when a VSP Channel Pan Mode is selected to the USER setting, the settings within the Microphone Simulation Tool will be used as a basis for the underlying VSP panning law. These settings may be changed in real time, and the changes will be audible as they are being made. This is an exciting and functional tool that the mix engineer now has exclusively with the use of the VSP panning system within the Studer D950 or Vista consoles.

3.4.4 VistaMix (VMX)

Basics Studer VistaMix is an automatic mix algorithm based on gain sharing, introduced with SW V4.9. VistaMix processing comes in very handy in multi-microphone situations, such as round-table discussions or unscripted games shows, in which indirect voice and early reflection-spill negatively affects the summed mix. It reacts faster and much more precisely than any human operator could possibly be, thus avoiding late fade-ins.

Working Principle The concept of VistaMix is to analyse the input channels assigned to the VistaMix group, and only open the gain of those channels that have active speakers talking. By reducing the gain of non-active talkers, spill, studio noise and ambience is greatly reduced. VistaMix calculates the gain of the contributing channels in such a way that the cumulative gain of all member channels always equals the gain value of one open microphone. This avoids modulation of the ambience and background noise. *Please note that this system does not use gates or expanders.*

The four situations in the example image below, with 3 speakers each, show the reaction of VistaMix (Gain) according to the actual individual input levels (dB SPL).

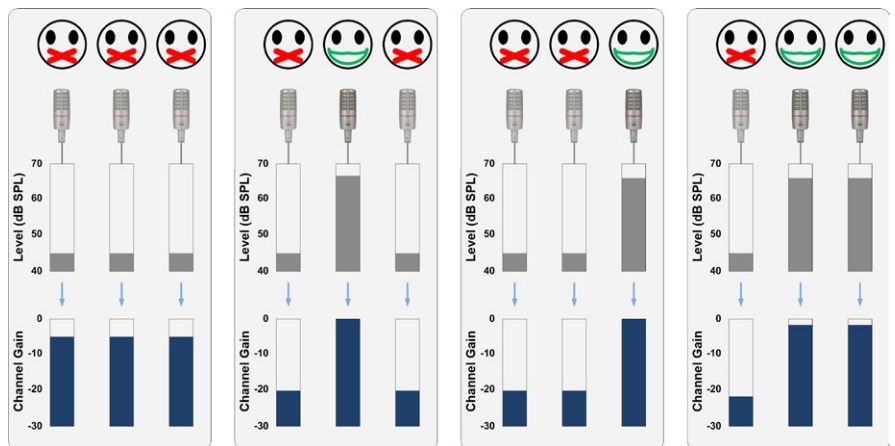

The VMX Bus VistaMix functionality is integrated into a new ‘VMX’ mix bus type, to which any mono channel can be routed. The VMX bus colour representation on the Vistonics screens is cyan. *Please note that stereo and surround channels may not be routed to VistaMix busses.*

There are two Bus types – mono and stereo output. Each type may be configured with 8, 12, 16 or 20 maximum contributing mono channels. Unlike conventional bus types, the VMX bus types can only be configured by adding a VMX channel. The configuration tool will then automatically construct the channel/processing/bus structure.

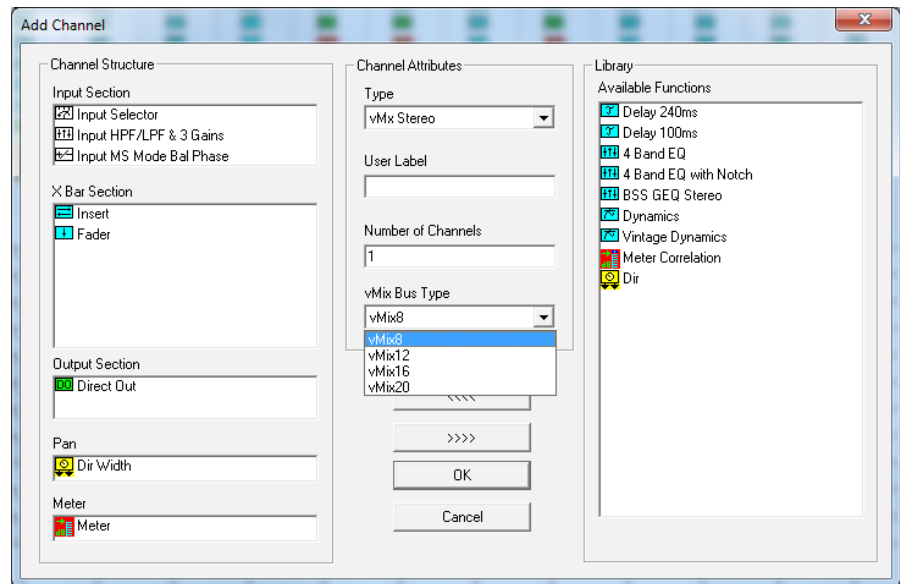

To use VistaMix processing, the SCoreLive Config Editor V1.85 is required; it is included in the SW V4.9 upgrade. Several instances of both mono and stereo VistaMix channels may be configured in a single DSP configuration. If you wish VistaMix channels to slave or re-enter, you will need to add the appropriate bus links in the configuration tool's Channel Bus page. Naturally, normal channel DSP processing, such as EQ, dynamics etc., may be added as usual.

Contributing channels can be assigned to VistaMix busses from the regular bus assign view. The assignment is exclusive, that is, a channel can only be member of one VMX bus at the same time. Channels that feed a VMX bus will show one (mono vmx) or two (stereo vmx) miniature fader symbols in the label area of the Vistonics display. These show the gain of the VistaMix function dynamically and are *not* audio level meters.

Note: *Only mono channels can be assigned to VistaMix busses.*

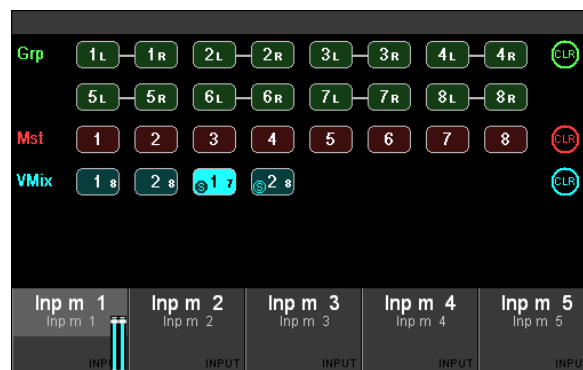

The audio to the VistaMix processing is always post fader from the source channel. It is also possible to route the post fader signal to 'normal' busses, AUXes, groups and masters, but no VistaMix gain control will be applied to these busses.

VistaMix Master Channel

Master channels will appear in cyan in the strip assign page and may be assigned to the faders in the normal way. The Vistonics view of the VMX bus parameters is opened by touching the Vistonics PAN icon of the desired bus.

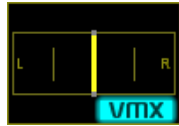

The VMX bus parameters appear next to the channel's PAN parameters.

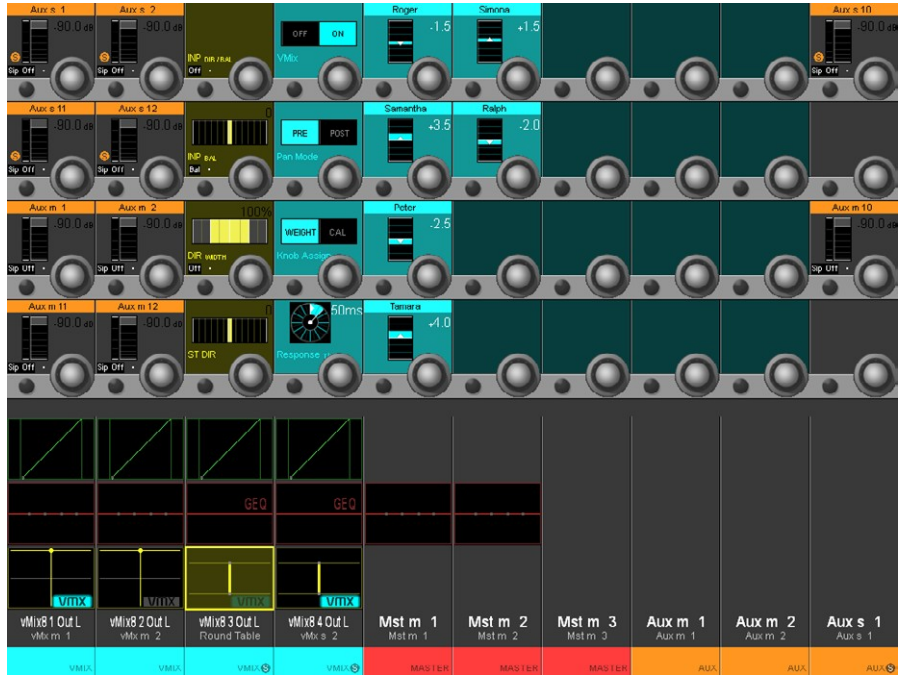

VistaMix Parameters

VMix



This parameter turns the VMX function On and Off.

In the Off state, the assigned channels' contributions to the bus are only depending on their input fader setting, as with usual channel contributions to standard busses.

Knob Assign



Changes the parameter value between CAL and WEIGHT that are both controlled on the contributing channels' side. Both CAL and WEIGHT of the contributing channels can be set either in the VMX bus parameters shown above or, after selecting **GLOBAL VIEW – DLY-INS**, with the lowest Vistonics knob in the corresponding channel strip.

During setup, first the CAL of all the talkers is set, adjusting the microphone balance in the mix when several talkers are speaking at the same time. If only one person is talking, the gain will not be affected. The contribution of the channels of the persons currently not talking is automatically adjusted in such a way that the ambience level remains constant.

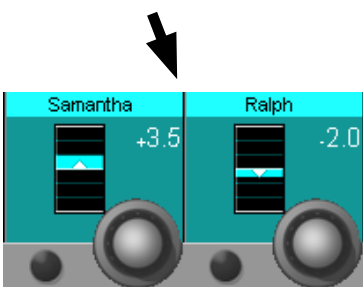

WEIGHT can then be used to control the relative levels of persons (such as the moderator – Samantha in the example at the left) that are given priority over the other participants, so that this person gets more gain relative to the others in the mix, if several persons are talking at the same time. WEIGHT may also be helpful for a talker with a thin voice.



Response Time The response can be set from 20 ms up to 4 s. Recommended setting is 50 ms but the engineer's ears have to decide. The response time cannot be compared with release and attack times of dynamic processes. This time sets how fast the crossfades between the calculated gain values are executed and how fast VistaMix is reacting on the occurring changes of the signals.



Pan Mode The pan mode parameter defines where the PAN values of the individual contributing channels are calculated. This applies for stereo VistaMix master channels only (on mono VistaMix masters this parameter is automatically blanked).

Normally dialogue is kept pretty central or even mono, so this is not an issue. If however significant panning of the source channels is applied, then moving the source channel pan function may change the acoustic effect of VistaMix operation. Depending on the amounts of panning, there is a compromise between dialogue moving and background noise and spill changing.

Initial settings from the comparison table below are recommended. But some own experimenting will do no harm, and the final decision is up to the engineer's ears.

| Pan Mode | Pro | Con | Panning Level Dependency | Recommended: |
|----------|-----------------|-----------------|------------------------------|---|
| POST | Stable Speakers | Moving Ambience | Better for lower Pan values | Quiet environments and/or low pan values (Studio) |
| PRE | Stable Ambience | Moving Speakers | Better for higher Pan values | Loud environments and/or high pan values (Field) |

3.4.5 General 5.1 Surround Channel View

Pressing VIEW: CHANNEL brings up an overview of the channel selected with the LINK / SEL key, covering the whole Viconics TFT. All available parameters are shown in the rotary section, except for dynamics, EQ, and panning. Only visible parameters are available for adjustment.

As can be seen below, there is an additional selection possibility in the touch area that allows modifying the EQ and dynamics parameters individually for the Front, Center, LFE and Rear signals.

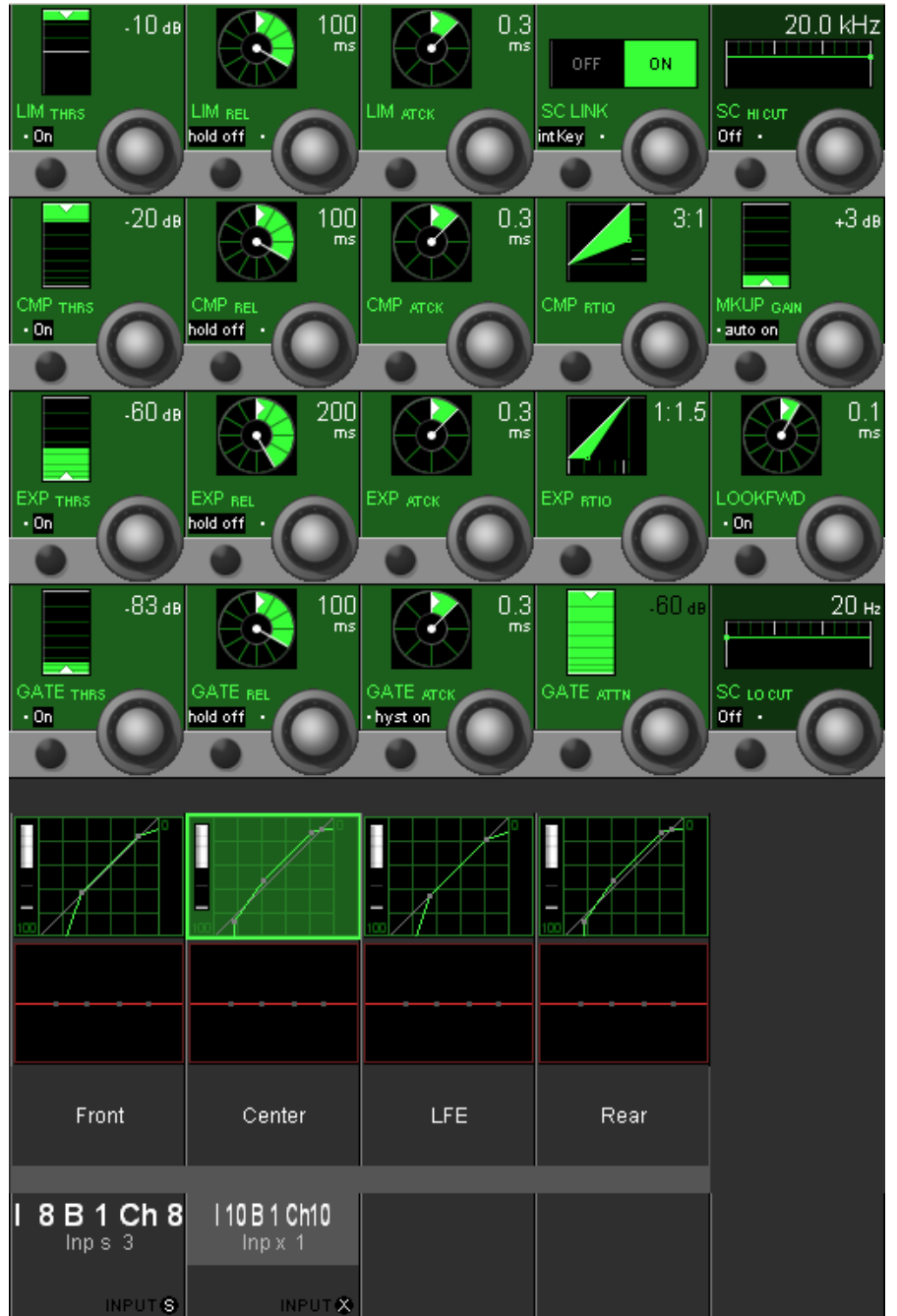

Upon touching one of these fields (e.g. the green 'Center' dynamics field) the display changes to the individual dynamics setting of the 'Inp x 1' 5.1 input's center channel.

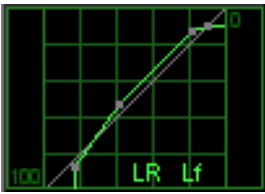

After the individual setting has been made, pressing **VIEW: CHANNEL** again switches back to the standard channel view. In our case (where the front and LFE channels of Inp x 1 have individual dynamics settings), the dynamics field then displays the standard dynamics curve with supplementary, small L, R and Lf characters, indicating that the front and LFE dynamics settings are different from the displayed curve. A gain reduction bargraph is shown at the left of each of the four individual dynamics icons.

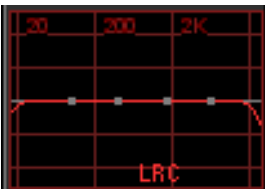

Individual EQ settings for the different surround signal legs can be adjusted and are indicated in the same way.

3.4.6 Misc View (Miscellaneous Parameters)

Pressing **VIEW: MISC** brings up an overview for the channel selected with the **LINK / SEL** key, covering the whole Vistonics TFT. The *most important* parameters of a channel's dynamics, EQ, and pan sections are shown in the rotary section. Only the visible parameters are available for adjustment.

3.4.7 Bus Assignment View

When pressing **VIEW: BUS ASN**, the display changes to the bus assign window of the selected channel.

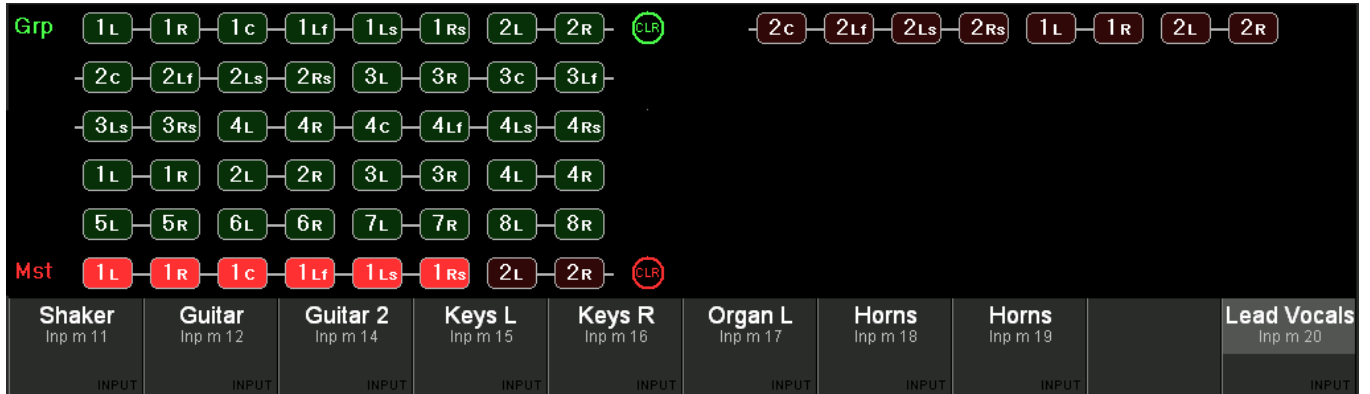

Only buses are shown here to which the current channel can be assigned. Pressing **VIEW: BUS ASN** on a master channel, however, will activate the ‘inverse bus interrogation’ view described below. The CLR buttons will clear the assignment to *all* buses of the corresponding type.

Inverse Bus Interrogation

Pressing **VIEW: BUS ASN** on a group master, an AUX master or a master channel (having a bus routed to its input) opens the Strip Setup dialog on the GC screen, showing the currently assigned channels in magenta color. When pressing **VIEW: BUS ASN** on an N–X owner channel, the inverse bus interrogation is done on the associated N–X bus.

CHAPTER 4

| | | |
|-----------|---|----------|
| 4 | Graphical Controller Operation | 5 |
| 4.1 | Introduction | 5 |
| 4.2 | The GC Screen..... | 7 |
| 4.2.1 | The View Button | 8 |
| 4.2.2 | The Quick Access Bar | 8 |
| 4.2.3 | The Ribbon Style Selector..... | 9 |
| 4.3 | Graphical Controller Basics..... | 10 |
| 4.3.1 | Sources and Targets | 10 |
| 4.3.2 | The Session Configuration | 10 |
| 4.3.3 | Labels | 11 |
| 4.4 | First Level: Main GC Pages | 13 |
| 4.4.1 | Working with Multiple Pages | 14 |
| 4.4.2 | The General Patch | 14 |
| 4.4.2.1 | General Patch Navigation..... | 16 |
| 4.4.2.1.1 | Navigating the Sources/Targets List..... | 16 |
| 4.4.2.1.2 | Other Navigation Methods | 17 |
| 4.4.2.1.3 | What Patch Groups are There? | 18 |
| 4.4.2.2 | How to Deal with the Analog Interfacing? | 19 |
| 4.4.2.3 | Digital Input/Output Subclasses | 19 |
| 4.4.2.4 | Making and Clearing the Cross-Points | 20 |
| 4.4.2.5 | Editing the User Labels in the General Patch | 23 |
| 4.4.2.5.1 | Sorting Options | 24 |
| 4.4.2.5.2 | View the Different Label Types..... | 24 |
| 4.4.2.6 | Working with Labels | 25 |
| 4.4.2.6.1 | Automatic Label Propagation..... | 26 |
| 4.4.2.7 | What are Device Labels?..... | 27 |
| 4.4.2.8 | How to Activate the Device Label Functionality..... | 28 |
| 4.4.2.9 | Where are the Device Labels Saved? | 28 |
| 4.4.2.10 | How to Create or Overwrite a Device Label | 28 |
| 4.4.2.11 | How to Edit an Existing Device Label | 28 |
| 4.4.2.12 | Background Information | 28 |
| 4.4.2.13 | Automatic Generation of Intelligent Fixed Labels | 29 |
| 4.4.3 | Channel Patch..... | 31 |
| 4.4.3.1 | Using the Channel Patch for Patching Audio | 32 |
| 4.4.3.2 | Setting the Order of DSP Processing Blocks..... | 33 |
| 4.4.3.3 | On-screen Toggles for Input Selector and Dynamics Key Selector..... | 33 |
| 4.4.3.4 | Editing the Channel User Labels | 33 |
| 4.4.3.5 | Set the Metering and Direct Out Source Point | 34 |
| 4.4.3.6 | Switch off the Label Inheritance | 34 |
| 4.4.3.7 | Setup & Activate the Dynamics Sidechain Link | 35 |
| 4.4.3.8 | Fader Ramp Control ('Audio Follows Video')..... | 37 |
| 4.4.4 | Snapshot Page | 39 |
| 4.4.4.1 | Snapshots | 40 |
| 4.4.4.2 | Multiple Snapshots..... | 43 |

| | | |
|------------|--|----|
| 4.4.4.3 | Snapshot Crossfading..... | 45 |
| 4.4.4.4 | Additional Snapshot Functionality | 46 |
| 4.4.4.5 | Partial Snapshots | 47 |
| 4.4.4.6 | Typical Applications | 49 |
| 4.4.4.7 | Snapshot Filtering (Static Automation) | 50 |
| 4.4.4.8 | Presets | 52 |
| 4.4.4.9 | Default Settings | 53 |
| 4.4.4.10 | Files and Backup | 53 |
| 4.4.4.11 | Recall Confirm | 54 |
| 4.4.4.12 | Option: Snapshot Automation | 54 |
| 4.4.5 | Cue List / Theatre Cue List | 55 |
| 4.4.5.1 | ‘Standard’ Cue List..... | 55 |
| 4.4.5.2 | Theatre Cue List..... | 58 |
| 4.4.5.2.1 | Cross-Fading Between Cues..... | 59 |
| 4.4.5.2.2 | Organizing Events | 60 |
| 4.4.5.2.3 | Updating Snapshots..... | 60 |
| 4.4.5.2.4 | BlackOut | 60 |
| 4.4.5.2.5 | Arm CueList..... | 60 |
| 4.4.5.2.6 | XFade Active..... | 61 |
| 4.4.5.2.7 | Preview..... | 61 |
| 4.4.5.2.8 | MIDI Show Control Device | 61 |
| 4.4.5.2.9 | MIDI Port Deactivation..... | 61 |
| 4.4.5.2.10 | Event Types..... | 62 |
| 4.4.5.2.11 | VCA / Channel Mute Mode..... | 69 |
| 4.4.5.2.12 | Isolate Labels and VCA Assignment | 69 |
| 4.4.5.2.13 | Mute Groups..... | 70 |
| 4.4.5.2.14 | Hard Mute | 70 |
| 4.4.5.2.15 | Cue List Options Menu | 72 |
| 4.4.5.3 | Theatre Workflow Tutorial..... | 73 |
| 4.4.5.3.1 | Console Setup..... | 74 |
| 4.4.5.3.2 | Building Cues..... | 75 |
| 4.4.5.3.3 | Rehearsal Phase..... | 78 |
| 4.4.5.3.4 | Shows | 81 |
| 4.4.6 | Strip Setup..... | 84 |
| 4.4.6.1 | How to Use the Strip Setup | 86 |
| 4.4.6.1.1 | Assigning a Single DSP Channel to a Single Channel Strip | 86 |
| 4.4.6.1.2 | Assigning Multiple Channels in one Single Action | 86 |
| 4.4.6.1.3 | Moving Already Assigned DSP Channels to Other Channel Strips | 87 |
| 4.4.6.1.4 | Useful Information | 88 |
| 4.4.6.1.5 | Labels in Strip Setup | 88 |
| 4.4.6.1.6 | Metering | 90 |
| 4.4.6.1.7 | FaderGlow..... | 92 |
| 4.4.7 | Clipboard Libraries | 93 |
| 4.4.7.1 | Clipboard Library Window | 94 |
| 4.4.7.2 | Paste into Clipboard Library | 94 |
| 4.4.7.3 | Copy from Clipboard Library..... | 94 |
| 4.4.7.4 | Rename/Delete a Clipboard Library File..... | 95 |
| 4.4.7.5 | Clear the Display..... | 95 |
| 4.4.7.6 | Update a Clipboard File | 95 |
| 4.4.7.7 | Storage Format | 95 |
| 4.4.7.8 | Import a Clipboard File from Another Library..... | 96 |
| 4.4.7.9 | Where are Clipboard Libraries Saved?..... | 96 |
| 4.5 | Second Level: The Application Menu | 97 |
| 4.5.1 | Titles and Projects | 97 |

| | | |
|-----------|--|-----|
| 4.5.2 | Save | 102 |
| 4.5.3 | Make/Restore Backup | 102 |
| 4.5.4 | Import..... | 103 |
| 4.5.5 | Export..... | 103 |
| 4.5.6 | Load DSP Configuration | 104 |
| 4.5.7 | Surveyor | 105 |
| 4.5.8 | Dynamic-Mode | 105 |
| 4.5.9 | Log In (as System Administrator) | 105 |
| 4.5.10 | About..... | 105 |
| 4.5.11 | Exit Vista Application | 106 |
| 4.6 | Third Level: Tools and Settings Ribbon Tabs..... | 107 |
| 4.6.1 | The Tools Ribbon Tab..... | 107 |
| 4.6.1.1 | General | 107 |
| 4.6.1.1.1 | Clipboard..... | 107 |
| 4.6.1.1.2 | Follow Solo | 107 |
| 4.6.1.1.3 | Offline Conference..... | 107 |
| 4.6.1.1.4 | Show Virtual | 110 |
| 4.6.1.1.5 | Machine Control..... | 110 |
| 4.6.1.2 | Setups | 111 |
| 4.6.1.2.1 | FX Engine | 111 |
| 4.6.1.2.2 | Meter/Generator | 111 |
| 4.6.1.2.3 | Shared Delay | 112 |
| 4.6.1.2.4 | VSP Properties | 113 |
| 4.6.1.2.5 | TC-Reader/Generator | 113 |
| 4.6.1.2.6 | N-1 Assignment..... | 113 |
| 4.6.1.3 | Signaling | 116 |
| 4.6.1.3.1 | Load Signaling Configuration | 121 |
| 4.6.1.3.2 | Save Signaling Configuration As | 122 |
| 4.6.1.4 | CGM | 122 |
| 4.6.1.4.1 | Control Group Basics | 122 |
| 4.6.1.4.2 | Control Group Setup | 123 |
| 4.6.1.4.3 | Control Group Filter..... | 124 |
| 4.6.1.4.4 | Control Group Assignment..... | 125 |
| 4.6.1.4.5 | Hierarchical CGMs | 126 |
| 4.6.2 | The Settings Ribbon Tab | 127 |
| 4.6.2.1 | System..... | 127 |
| 4.6.2.1.1 | Vista Settings..... | 127 |
| 4.6.2.1.2 | Downmix Settings | 130 |
| 4.6.2.1.3 | Sampling Rate | 130 |
| 4.6.2.1.4 | EQ/Dyn View | 131 |
| 4.6.2.1.5 | VCA Style Control Groups ('Motors Off')..... | 132 |
| 4.6.2.2 | Preferences | 134 |
| 4.6.2.2.1 | Load | 134 |
| 4.6.2.2.2 | Save..... | 134 |
| 4.7 | Fourth Level: SysAdmin functions..... | 135 |
| 4.7.1 | Tools: Control Group Assign | 136 |
| 4.7.2 | Settings: Show VMC Tree | 136 |
| 4.7.3 | Settings: FX HiQnet Audio..... | 136 |
| 4.7.4 | Settings: Ember Control..... | 136 |
| 4.7.5 | Settings: Reduced Function Set | 138 |
| 4.7.6 | Settings: General Patch Edit | 138 |
| 4.7.7 | Settings: Edit Monitoring Files | 142 |

| | | |
|------------|--|-----|
| 4.7.8 | Settings: Enable Monitoring Setup-Mode..... | 144 |
| 4.7.9 | Settings: Reinitialize Monitoring | 144 |
| 4.7.10 | Settings : Device Labels (Save and Apply)..... | 145 |
| 4.7.11 | Settings: Use DeviceLabels | 145 |
| 4.7.12 | Settings: Overwrite Channel User Label..... | 145 |
| 4.7.13 | Settings: Configure ExternalRouter I/O..... | 145 |
| 4.7.14 | Settings: Connection Setup | 145 |
| 4.7.15 | Settings: Regenerate Intelligent Fix Labels | 145 |
| 4.7.16 | General Patch: Enable Pro-Bel Setup | 146 |
| 4.7.17 | General Patch: Pro-Bel Setup | 146 |
| 4.7.17.1 | 3 rd -Party Control of Console Patch (Native Pro-Bel P-02/08 Support) | 146 |
| 4.7.17.1.1 | Pro-Bel P-08 support | 149 |
| 4.7.17.1.2 | Exclude Certain Patch Targets from Being Changed by Snapshots | 150 |
| 4.7.17.1.3 | Label Import from 3 rd -Party Systems..... | 150 |
| 4.7.17.1.4 | Support of External Monitoring Source Selector Panels..... | 151 |
| 4.7.18 | Snapshot: Output Snapshot Isolation | 152 |
| 4.8 | Fifth Level: The Surveyor..... | 153 |

4 GRAPHICAL CONTROLLER OPERATION

4.1 Introduction

The graphical controller (GC) is an essential part of the Vista system's operation, because it enables the user to utilize all of its enhanced functions, such as the snapshots, book-keeping and much more. It is also the place where the operating software is started and shut down – becoming, in fact, the console's main operations center.

All the operating software – consisting of a large number of individual files needed for proper operation of the console – is saved on the Control PC's hard disk. Even if there are hundreds of configuration, snapshot, and related files saved here from previous Vista sessions, the user basically needs to start only *one* application program: **D950SYSTEM.EXE**.

The **D950SYSTEM.EXE** is represented by the Studer Vista shortcut icon on the GC monitor screen:

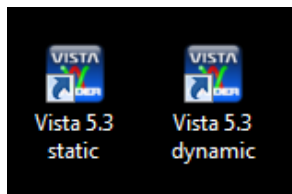

Depending on the desired operating mode (static, i.e. with snapshot automation, or dynamic, i.e. with the AutoTouch+ dynamic automation), use the appropriate icon.

If Virtual Vista (see [chapter 2.11](#)) should be used for controlling the core *in parallel* with the console, it always starts in the same static or dynamic mode in which the console was started. In dynamic mode, however, operation is much more convenient with the touch-sensitive desk controls. For the dynamic mode, Virtual Vista only has a limited range of applications, such as entering/editing labels.

The Vista software runs under Windows. All files used by Vista and all files produced by the user (snapshots, mixes, etc.) are fully compatible with the Windows standard. This means that they can be copied to other compatible media, using the Make Backup utility and standard Windows tools and procedures. Long file names (more than eight characters) are supported.

One of the advantages of using standard Windows techniques is that the majority of users will already be familiar with operating a PC-based system. Because all screen and touch pad procedures are derived from the Windows operating systems, please refer to the appropriate manuals if you are not familiar with using them.

Operation of the graphical controller is also fully Windows-compatible. Text strings, files, or even pictures can be copied from one location to the other using the Windows clipboard principle and keyboard shortcuts: **Ctrl + c** will copy to, and **Ctrl + v** will paste from the clipboard. This technique can be used, for example, to enter repetitive labels into the user labels, or for copying mixes from one title to another.

Full use is made of the Windows-standard, context-sensitive menus that can be accessed by the right touch pad button. The same is valid for conventional double-click techniques. The **Tab**, **PgUp/Dn**, and **arrow** keys behave according to standard Windows operation.

The graphical controller's screen colors, screen sizes, individual window positions and sizes, certain font sizes etc., are also part of the Windows Screen Properties, and can be adjusted there.

Because the graphical controller's user interface can be configured to suit the individual needs of specific users, all the graphics shown in this operating instructions manual may differ slightly from what you will see on the GC display of *your* Vista digital console.

4.2 The GC Screen

Upon starting the GC for the first time, the screen will look similar to this:

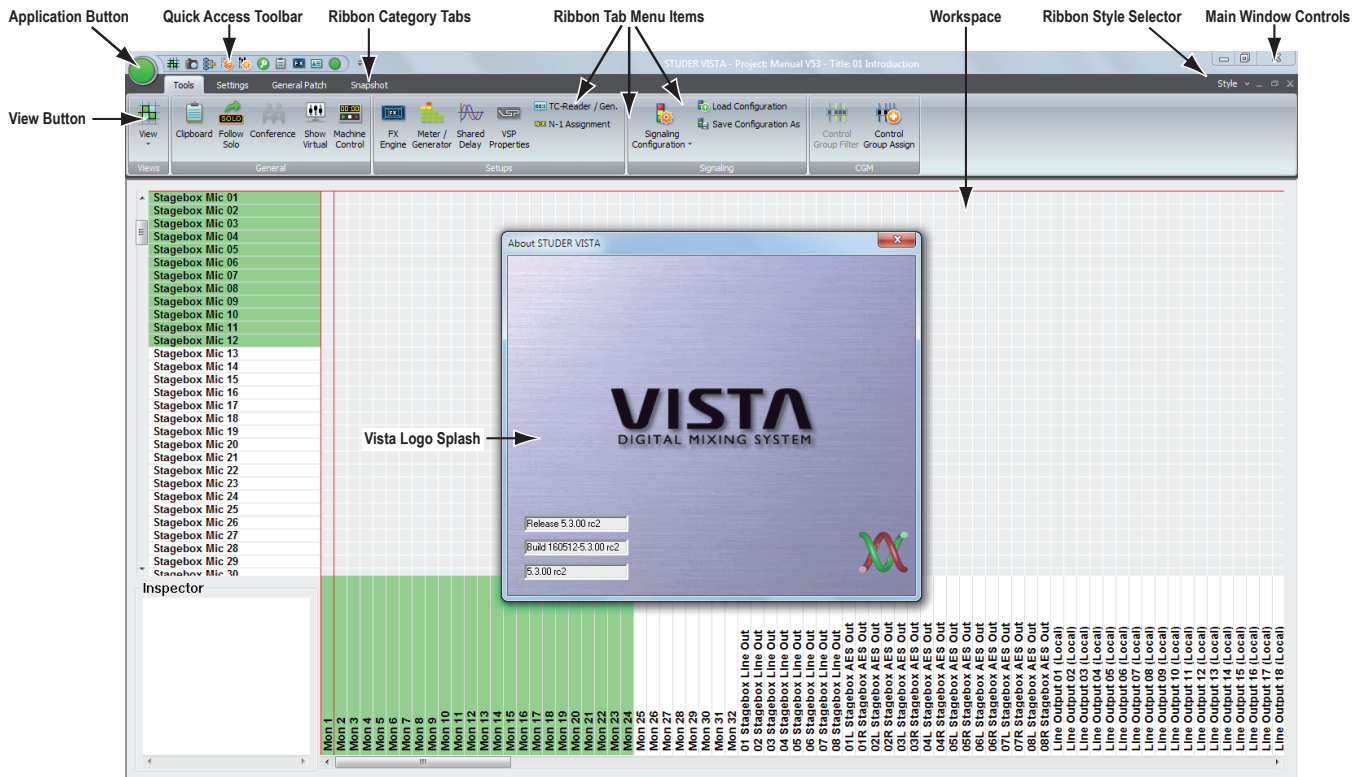

Please note the most important parts of the screen:

- The **Application Button**, allowing access to most of the Vista system's bookkeeping functions. Refer to [chapter 4.6](#);
- The **View Button**, containing various short-cut icons to navigate to the most important pages;
- The **Quick Access Toolbar**, a mini-toolbar that can be customized to contain frequently used menu items, independent of the currently selected view;
- The **Ribbon Category Tabs**, are containing menu items belonging to the tab's category. The category tab is automatically selected if the view is changed by using the view button;
- The **Ribbon Tab Menu Items**, displaying the necessary menu items that are matching the currently selected view;
- The **Workspace**, where you will open the Main GC pages and do other useful things;
- The **Ribbon Style Selector**, allows to choose the ribbon color style;
- The **Main Window Controls** (*minimize, maximize/window mode, quit*);
- The **Vista Logo Splash**, which will disappear a few seconds after the start.

4.2.1 The View Button

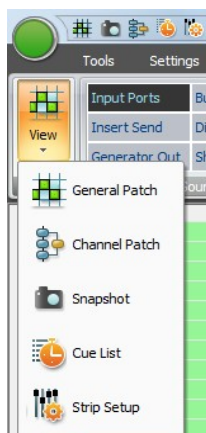

When clicking on the View button, the icons of the five main GC pages appear in a drop-down list.

Choosing the desired GC page not only opens this page, but also changes the Ribbon tab to the category that contains the menu items for this GC page.

Once the desired page is open, the page's icon is displayed in the View button area.

4.2.2 The Quick Access Bar

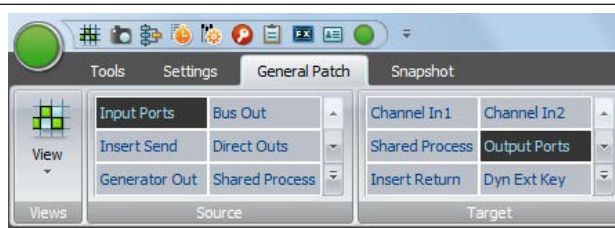

The *Quick Access Toolbar* is normally shown on top of the Ribbon menu. When clicking the customize button on the very right of the *Quick Access Toolbar*, a menu appears. Firstly, it provides a tick-list of all currently shown quick access menu items.

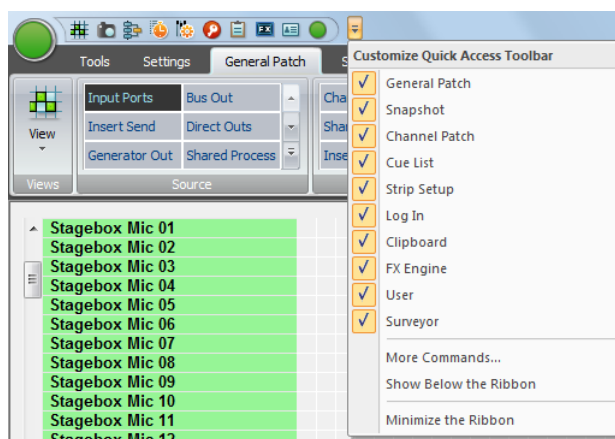

More Commands ...:

Secondly, three more functions can be chosen :

This function brings up the detailed configuration window where access to all menu items of all categories is provided. To do so, under 'choose commands from : ' the category tab can be selected. Then, a list of all menu items of this category is given :

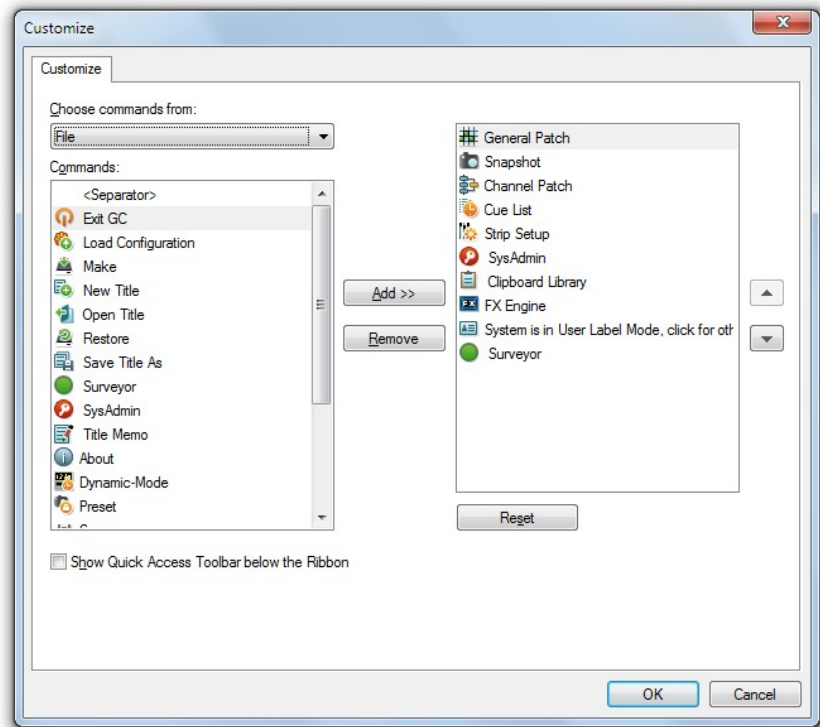

By choosing the desired menu item (also called 'Commands') and clicking on the Add button will add that specific menu item to the *Quick Access Toolbar*. The Reset button will bring you back to the state that the *Quick Access Toolbar* had before you started to modify it.

Show Below the Ribbon:

Selecting this function allows to place the *Quick Access Toolbar* underneath the Ribbon menu instead of above the Ribbon menu. Please note that this takes away some of the space which used to display the selected View Page.

Minimize The Ribbon:

This basically hides all menu items and only shows the *Ribbon Category Tabs*. More space is provided for the View Page :

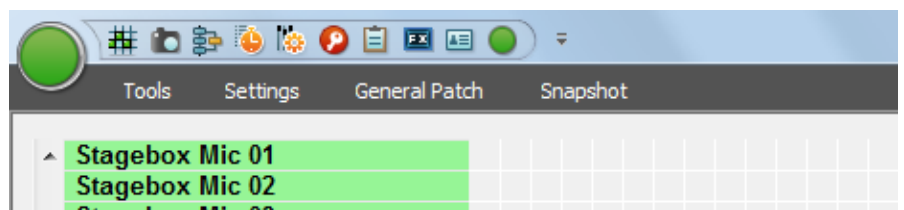

Please note that also double clicking on the *Category Tabs* toggles between minimized Ribbon and normal Ribbon View.

4.2.3 The Ribbon Style Selector

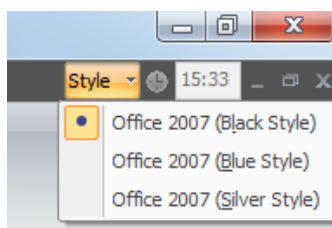

Here, the choice from three different window color-styles is possible. Please choose to suit your personal taste.

4.3 Graphical Controller Basics

This chapter describes the basic concepts of the work with the graphical controller (GC).

4.3.1 Sources and Targets

Generally, all audio signals available to the Vista can be divided into *Sources* and *Targets*. These names are used rather than ‘Input’, ‘Output’, etc., in order to avoid any confusion about where the audio signal comes from and goes to.

- Sources:** A *Source* is anything that delivers an audio signal:
- *Digital Input Interface* (e.g. AES/EBU or MADI);
 - *Analog Input Interface* (e.g. Mic/line input);
 - *Channel Output* (for example, direct output of input channel #24, master output, etc.);
 - *Channel Insert Send*;
 - *Bus Output* (unlike with analog consoles, any bus is a valid audio signal source within Vista; for example, AUX Mono Bus 12 can be used to feed an output interface, or to become the source to an input channel);
 - *Test Generator*.

- Targets:** A *Target* is anything that can receive one (mono or stereo) audio signal:
- *Channel Input 1* (first audio input to a channel; free for all input channels. It is used to connect Sources to input/track monitor channels, such as a MADI output from a digital multi-track to a track monitor channel, or the corresponding bus to an output channel, such as a Group, Master, or AUX channel);
 - *Channel Input 2* (second audio input to a channel; free for all channels);
 - *Channel Input 3* (third audio input to a channel; used for the test generator connection per default, can be re-patched to any source at any time);
 - *Channel insert returns*;
 - *Digital output interfaces* (e.g. AES/EBU or MADI);
 - *Analog output interfaces*.

Sources and Targets implicitly behave as mono or stereo, depending on their character. A *stereo* Source or Target can be treated, nevertheless, as consisting of two *mono* parts. Any Source can be connected to as many Targets as needed via the General Patch page. However, a Target (stereo or mono) can have only one Source (stereo or mono) assigned to its input.

4.3.2 The Session Configuration

The *Session Configuration* is the physical and electrical definition of the Vista Digital Mixing System installed at your recording studio or production facility. A Session Configuration contains data about the mixing console channels, the patch, the labels, and so on – and it *must* be loaded in order for the console to function.

We often refer to the *Virtual Mixing Console (VMC)* when speaking about the Session Configuration. VMC is another concept that forms the basic foundation of a Vista: all functions and the current Session Configuration

data are saved within the VMC. A simplified definition of the VMC is: ‘a data structure containing descriptions of the console’s functions, including all the current statuses of all functions.’

That is why, as we will see later, all the Session Configuration files have the extension *.vmc.

Because of the flexibility provided by the Session Configuration Tool, you can create customized, application specific, console configurations. In most cases the facility’s Vista system administrator will create the necessary Session Configurations. However, there are some cases where you will not need to be concerned with the Session Configuration, because the one configuration that was loaded at the Studer factory will remain loaded and active unless you changed it. The last-loaded Session Configuration will remain loaded and active until it either is changed, or another one is loaded.

If a production is recalled that was created with another Session Configuration, the correct Session Configuration will be automatically loaded.

For information on the Session Configuration Tool please refer to [chapter 6](#).

4.3.3 Labels

Labels are used extensively within the system to define objects, such as audio sources, channel names, etc., and to visualize these objects in various windows within the GC.

Please note that all labels are saved within snapshots and presets, together with all audio settings.

There are various ways to work with labels within the system. For a description of how to use labels, refer to [chapter 4.4.2.6](#). Basic label types are described below:

Fixed Labels These are generated automatically at the time of system configuration, and are used to identify *hardware-oriented* objects. For example:

| Fixed Label | Meaning |
|-------------------------------|---|
| AES In 4L (Local) | AES/EBU, physical input no. 4, left channel, on internal ('local') AES/EBU I/O module |
| Line Output 07 (Local) | Line, physical output no. 7, on internal ('local') analog line output module |

Fixed labels cannot be modified by a normal user, only the system administrator is allowed to do so. *However this is not recommended.*

User Labels These by default are identical to the fixed labels when starting a new title using one of the pre-configured templates. The user is allowed to rename these User labels in the GC to make the system environment more user-friendly. User labels are used to give the objects a useful, *application-oriented* name.

For example:

| Fixed Label | User Label | Meaning |
|------------------------|------------|--|
| AES In 4L (Local) | DAT 1 | DAT Player 1, coming in via AES/EBU, physical input no. 4, leftchannel, on internal ('local') AES/EBU/Omodule |
| Line Output 07 (Local) | Foldback 1 | Line, physical output no. 7, on internal ('local') analog line output module, is the foldback Send 1 to the Studio Floor |

Inherited (or Device) Labels

Inherited labels are used primarily to identify the *Source Signal* that is connected to the Channel Strip, rather than the user label of the Channel. In this way, as soon as the signal is connected to a channel's input, the channel strip display inherits the Label from the actual Source.

4.4 First Level: Main GC Pages

There are five main graphical controller pages, each of which deals with a different operating part of the Vista system:

- General Patch page
- Channel Patch page
- Snapshot page
- Cue List page
- Strip Setup page

These main pages can be accessed in three different ways:

- From the View button, by clicking on the appropriate icon:

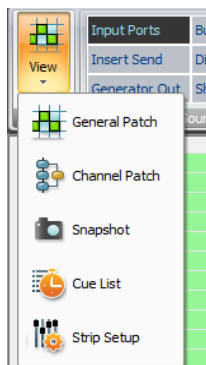

- Using the *Quick Access Toolbar* icons, by clicking on the appropriate icon in the *Quick Access Toolbar*, or
- Using the function keys in the desks control bay above the trackpad – which is probably the fastest way:

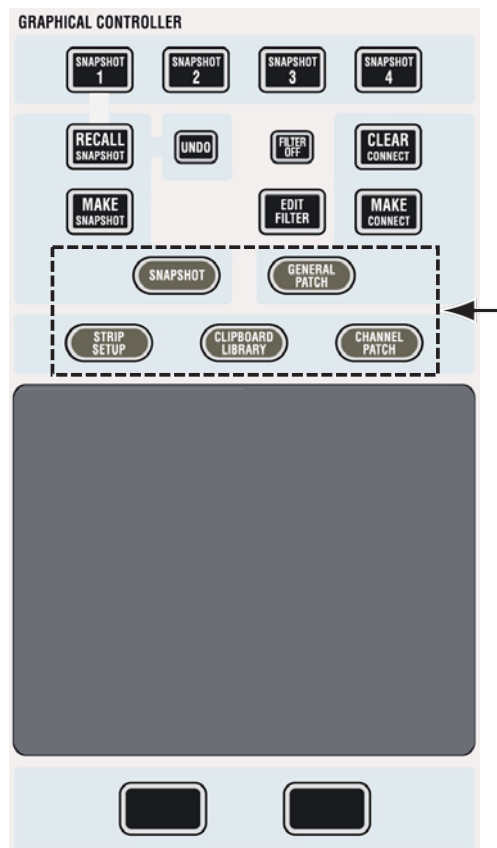

4.4.1 Working with Multiple Pages

Working with multiple pages is not possible with the new Ribbon style menu.

4.4.2 The General Patch

The GC General Patch page can be accessed in three different ways:

- From the View button, by clicking on the appropriate icon
- Using the *Quick Access Toolbar* icons, by clicking on the appropriate icon
- Using the GENERAL PATCH function key. This is the fastest way.

The General Patch is the main tool used to establish and clear audio connections within the system. The name 'Patch' is used because it mimics the conventional patch bay used in analog consoles. It accomplishes all the tasks of a conventional patch bay, and much more. Patch cross-points are saved into the snapshot/preset memories.

It utilizes an X-Y axis (or side-to-side/up-down) representation to aid viewing and editing of existing connections or cross-points (equivalent to the location of patch cords), and all existing Sources and Targets (equivalent to the patch-jack pairs used in most patch bays).

The General Patch can be thought of as a number of 'sub-patches' whereby either single groups of the sources and targets can be viewed at a time, or any predefined combination of sources and targets by using the *User Patch Groups*.

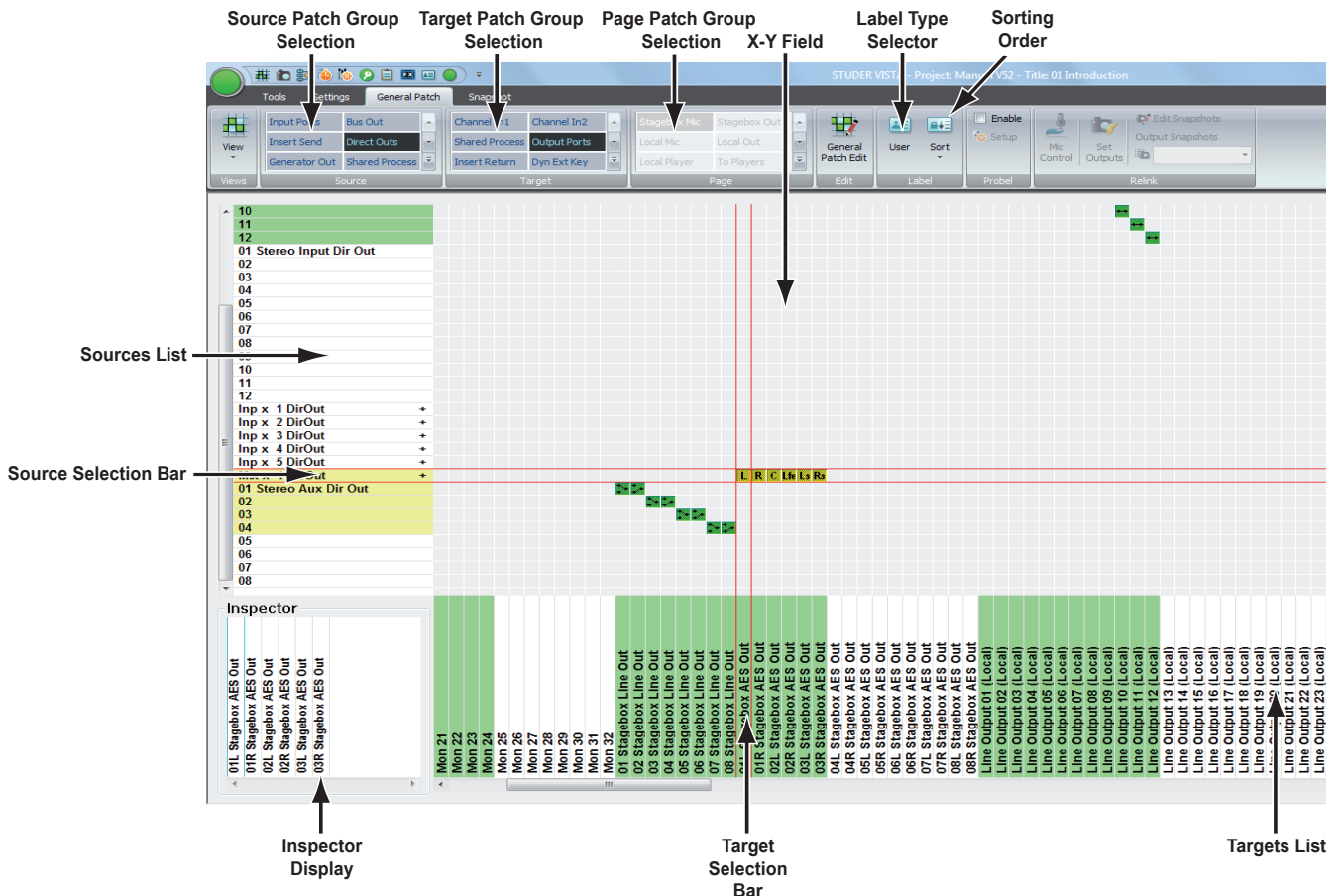

The General Patch consists of:

- A Targets list (the lower horizontal, or x axis), equivalent to the lower jack row in a patch bay
- A Sources list (the left-hand vertical or y axis), equivalent to the upper jack row in a patch bay
- The X-Y field, where the cross-point icons enable interrogation and editing of cross-point connections
- The Source- and Target Patch Group selection
- The Page Patch Group selection (navigates both, Source- and Target lists)
- The Source- and Target selection bar, which allows choosing a crosspoint
- Viewing selections which allow sorting of the Sources and Targets Lists by label type
- The Fixed/User Label displays for the selected Source/Target
- The Inspector Display.

4.4.2.1 General Patch Navigation

4.4.2.1.1 Navigating the Sources/Targets List

The audio sources list (located on the Y axis) and the targets list (on the X axis) allow the user to find and select a Source/Target pair, and to make or clear a required cross-point connection.

There are different ways to navigate and select the required source and target for making or clearing patch connections. The simplest process to select the required Source/Target selection is described below:

- 1 Select the Patch Group of the required source/target using the Source- and Target Patch Group selector. This will show in the X-Y axis list all the possible sources/targets available in the configuration currently loaded. Scrolling using the standard windows scroll bar may be required to see all the sources/targets from the chosen Patch Group. Select the required Source/Target by clicking on the Source/Target name or by using the keyboard cursor arrows to move up and down the list. This will position the Selection bars of the X-Y axis to the chosen Source/Target. The intersection of the two Selection bars will allow the making or clearing of a cross-point based on the chosen Source and Target (see chapter 4.4.2.4 for information on how to make or clear cross-point connections).

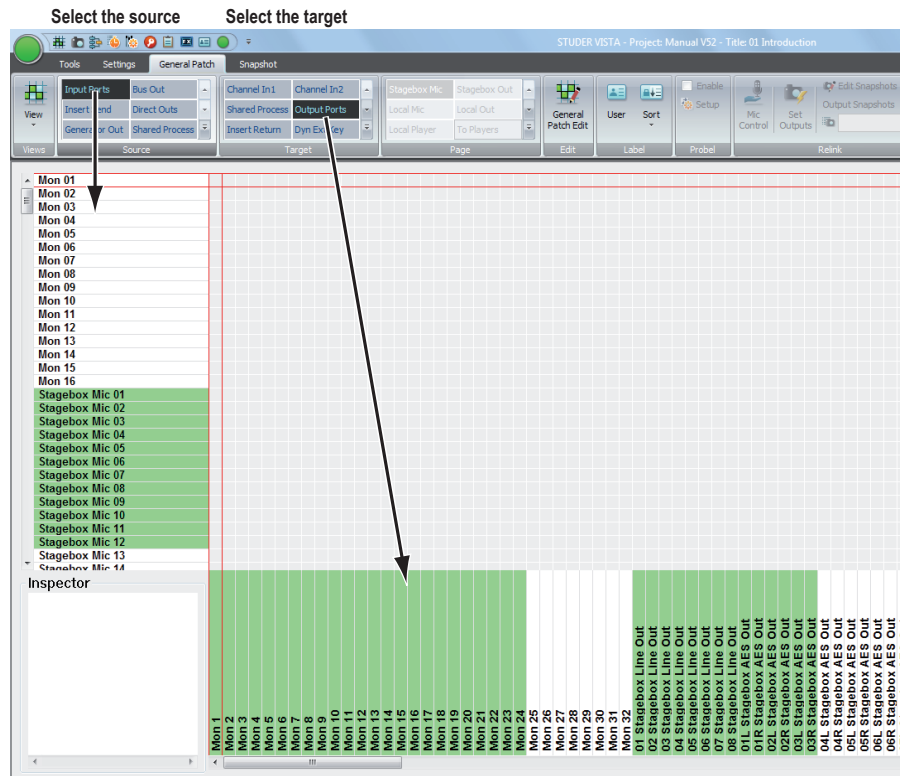

- 2 Select the required Page Patch Group in the Page Patch Group selector. This will show the X- and Y axis of the predefined Patch Group at once. Proceed as described above to select source and target.

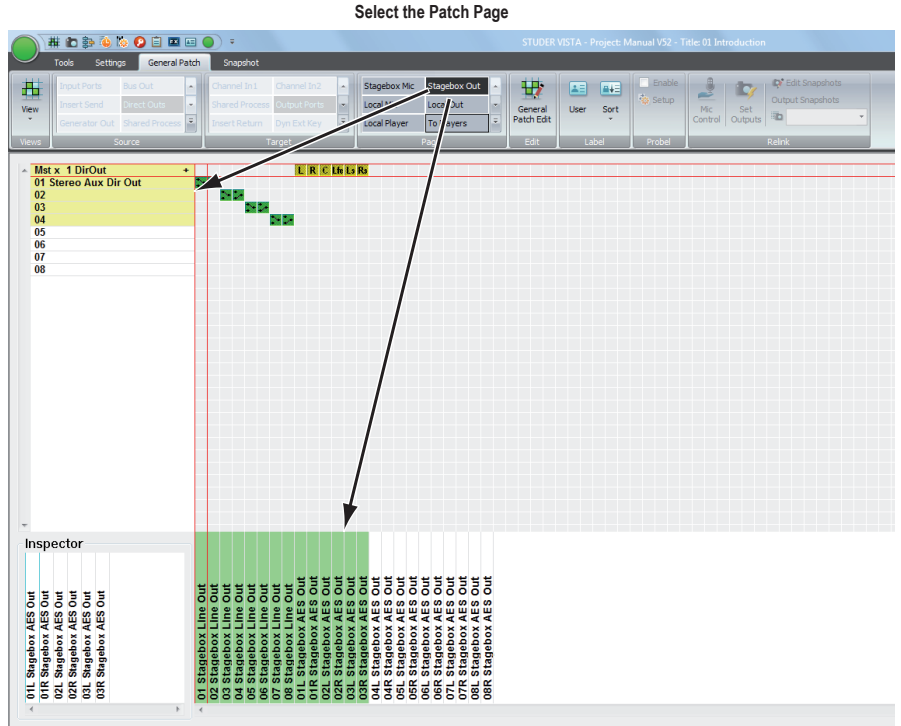

4.4.2.1.2 Other Navigation Methods

Using of Color for Navigation:

Color is used in the Sources and Targets lists to give a clear indication and overview of the sources and targets which have connections patched. If a Source is connected to a Target or multiple targets, the Source label in the Sources List will be highlighted by a color. Similarly, if a target is connected to a Source or a number of different Sources, then the Target label in the Targets List will be highlighted by a color. The meaning of the colors is as follows:

| |
|--------|
| GREEN |
| YELLOW |
| RED |

- A single connection is made to the indicated Source or Target.
- Two or more connections are made to the indicated Source or Target.
- The Target has a protected connection.

If a Source or Target is highlighted (indicating a connection has been made to it), double-clicking on the label in the Sources/Targets Lists will navigate directly to the cross-point so that the Source Selection bar and Target Selection bar intersect at that cross-point. This is an extremely fast method to find what is connected to a Source or Target without the need for scrolling or manual searching of the sub patches. If a Source or Target is highlighted in Yellow (indicating two or more connections are made to it), double-clicking on the label in the Sources/Targets Lists will navigate directly to the first cross-point. Subsequent double-clicks will navigate to each of the following connections that are made to the Source/Target in question. If all connections have been shown, a further double-click will return the user to the first connection and loop around the connections once again with further double-clicks.

4.4.2.13 What Patch Groups are There?

There are different, fixed Patch Groups for each of the Sources and Targets Patch Group selectors :

Sources:

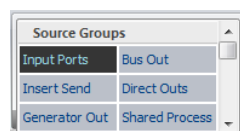

Targets:

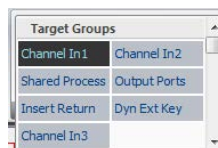

Each Patch Group contains a number of Sources or Targets, depending on the currently loaded configuration. Sometimes certain sections will not be present; for example, if no Channel Inserts have been configured, there will be no Insert Send section within the Sources List, and no Insert Return section within the Targets List.

The size of the X-Y General Patch automatically adapts to the number of channels, input interfaces, output interfaces, and to the presence of DSP function blocks in the channels – as defined in the currently loaded configuration.

Some detail information on the sections:

Source Patch Groups:

| | |
|-----------------------|---|
| Dir Out | All Direct Outputs of all channel types. |
| Input Ports | All input audio interfaces (AES/EBU, MADI, or D21m A/D converters). |
| Insert Send | Sends from the inserts of all channel types. |
| Bus Out | Unlike analog consoles, with the Vista any bus is a valid audio signal source; e.g. an AUX mono bus can be used to feed an output interface, or to become an input to an input channel. |
| Generator | The test generator's signal. |
| Shared Process | All outputs of the shared process DSP section, such as CR/ST monitoring, downmixers, shared delays, etc. |

Targets Patch Groups:

| | |
|-----------------------|---|
| Channel In1 | First audio input to all channel types, <ul style="list-style-type: none"> • Free to use for all input channels, • Used for default connection of the corresponding Bus for an output channel, such as a Group, Master, or Aux channel. |
| Channel In2 | Second audio input to all channel types, <ul style="list-style-type: none"> • Free for all input and output channels. |
| Channel In3 | Third audio input to all channel types, <ul style="list-style-type: none"> • Used for the Test Generator connection per default, • Can be re-patched to any source at any time. |
| Output Ports | All output audio interfaces (AES/EBU or MADI, D/A converters). |
| Insert Returns | Returns to the inserts of all channel types. |
| Dyn Ext Key | Input for the external control signal (key) to the Dynamics Sidechain of all channel types. |
| Shared Process | All inputs to the shared process DSP section, such as CR/ST monitoring, downmixers, shared delays, etc. |

4.4.2.2 How to Deal with the Analog Interfacing?

There is no difference between analog and digital interfacing. The respective D21m I/O card incorporates the A/D or D/A converters and provides digital signals to- and from the system.

4.4.2.3 Digital Input/Output Subclasses

Subclasses are not used with the new General Patch page anymore.

4.4.2.4 Making and Clearing the Cross-Points

The creation and updating of cross-points is simple. First, select the source and target; the selection bars have to be crossed to form an X-Y pair.

There are two ways of making or breaking a cross-point connection:

- By double-clicking the left touch pad button, while the cursor is positioned over the crossed Selection bars, or
- Using the CLEAR CONNECT and MAKE CONNECT function keys in the desks control bay:

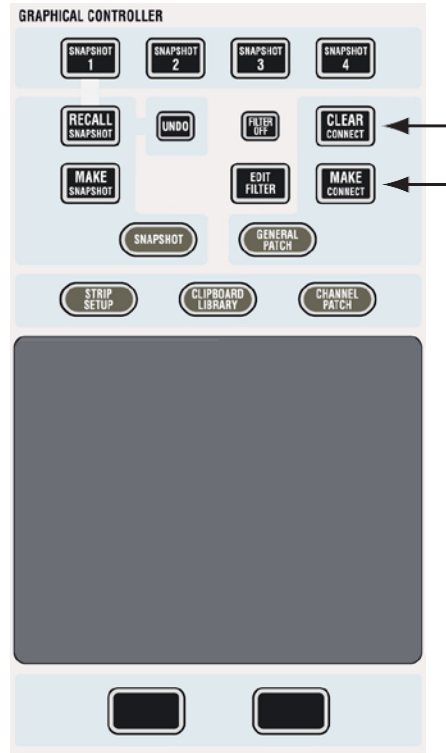

Using the MAKE CONNECT (make connection) function key will always make a default connection, depending on the Source- and Target-type combination. Using the CLEAR CONNECT (clear connection) function key will always clear any cross-point connection. (This is the *fastest* method to make or clear a connection.)

Double-clicking the left touch pad button: This method is more sophisticated, because it allows you to select from a *number* of connection options displayed in a pop-up menu box. The menu display depends upon the combination of Source (mono or stereo) and Target (mono or stereo). The uppermost connection type in the menu is the default connection type, which is applied if you use the function keys, as shown above.

Mono Source – Mono Target

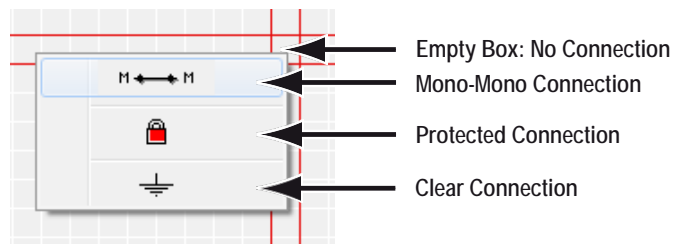

Stereo Source – Mono Target

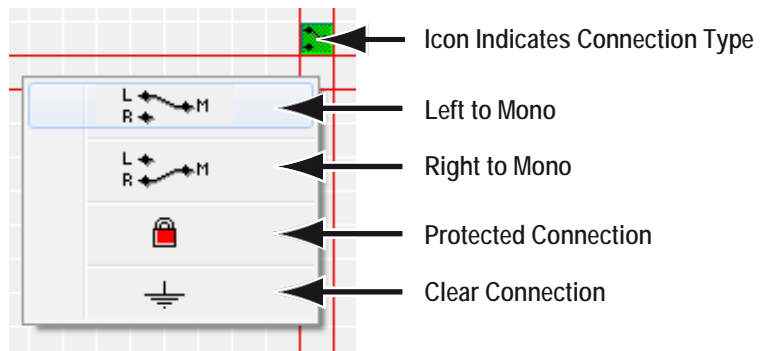

Mono Source – Stereo Target

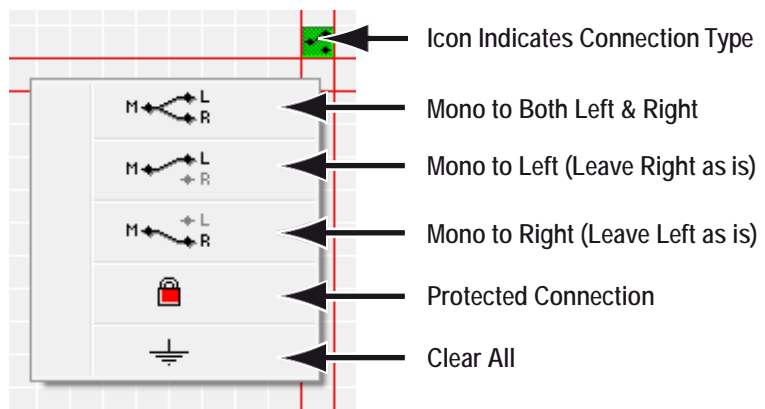

Stereo Source – Stereo Target

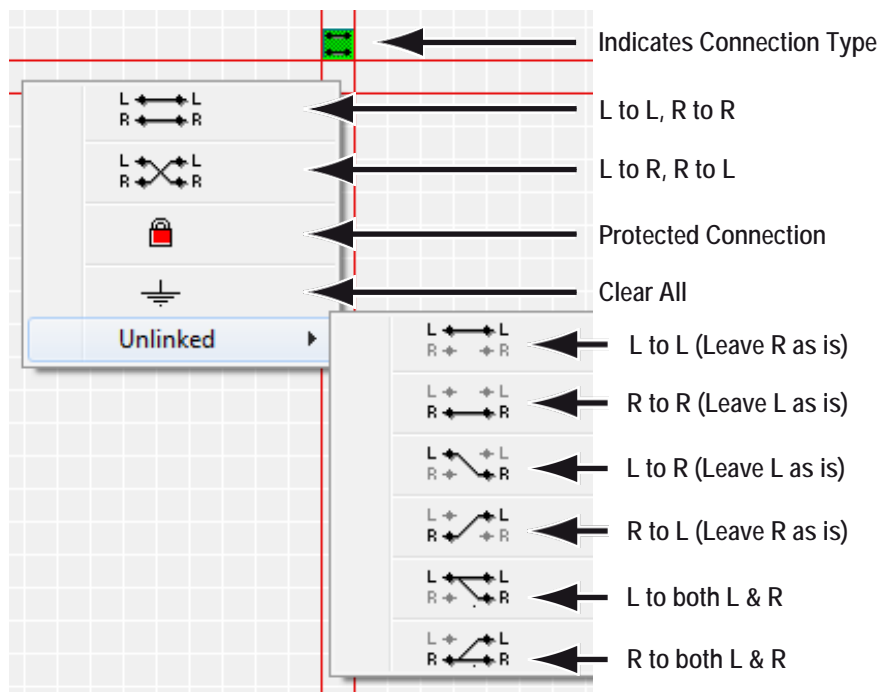

The last menu allows *unlinked* operation, a phrase that refers to a Stereo Target being unlinked and its left and right components used with *different* Sources. Such cross-point connections enable one Target to be connected with *two* Sources, and are indicated with a *yellow icon*.

Tip A feature is available for fast diagonal patching of multiple Sources to multiple Targets. The example below shows this feature used in practice.

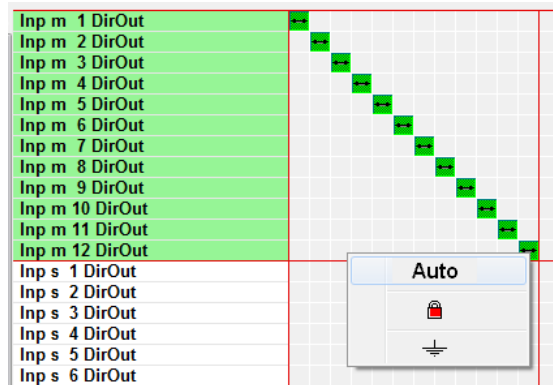

- By *keeping the left touch pad button pressed* while dragging the pointer across a region in the General Patch view, multiple connections can be selected now.
- While the left touch pad button is still pressed, a *right-click* opens a selection window; when Auto is selected, any desired number of patch points can be connected at the same time.

In the same way, multiple patch points also may be locked, unlocked or cleared in one go.

- A *double-click* on a patch point allows either connecting or disconnecting this patch point *immediately*.

Patching Surround Sources

A surround source can very easily be patched to a 5.1 input channel by using the ‘auto’ patch facility, where all six discrete mono sources are patched at once and with one single click. Moreover, there is a ‘+’ unfold icon with every 5.1 target. When clicking on it, all 6 individual legs of the surround target are shown and can be patched in any desired order. Clicking on ‘-’ closes this view to show only one single patch connection again.

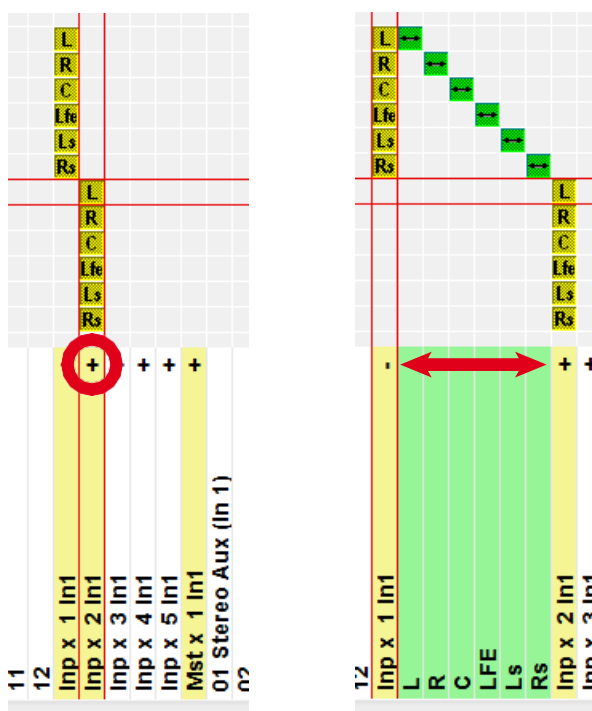

Connection Protection

It is also possible to protect a certain connection from accidental change both by the user or by recalling a snapshot. Right-clicking on a connection allows to select the padlock item to lock the connection. To unlock, right-click again. Both the background of the Target as well as the connection become red. When attempting to change a protected connection, a warning appears, together with the instructions on how to unprotect the connection.

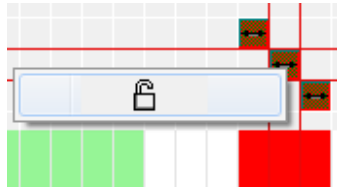

4.4.2.5 Editing the User Labels in the General Patch

In order to edit the user labels in the General Patch view, right-click on the desired Source or Target in the Sources/Targets list.

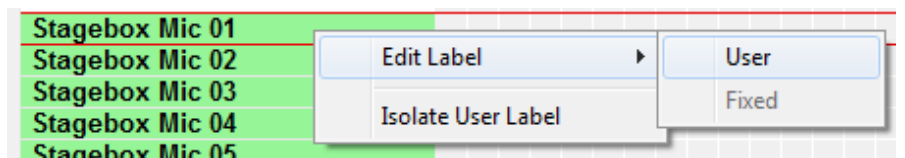

Click on the Edit Label field of the Source or Target and select the User label. This will open a dialog box that allows editing a user label, such as changing it from 'Stagebox Mic 01' to 'Snare':

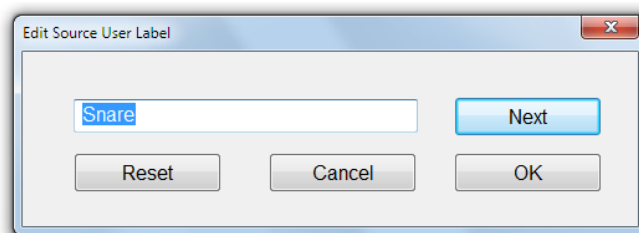

To automatically move to the next Source/Target in the list, either click on 'Next' or hit ENTER on the keyboard. To close the dialog box click on 'OK'. It is possible to choose a Source/Target from the General Patch list without closing the Edit User Label dialog box. Simply click on the desired Source/Target from the General Patch list with the window still open. This will automatically enter it into the window for editing. A click on 'Reset' will restore the 'Stagebox Mic 01' default user label.

User Labels with up to 13 characters (depending on the width of the individual characters) can be used for Input sources. These User Labels can then also be shown in the Vistonics area of each channel strip.

4.4.2.5.1 Sorting Options

There are two options for sorting the display of the Sources and Targets in the General Patch Lists. This sorting is independent of which label type is being displayed due to the global label mode selection.

Sort by Fixed Label: Independent of the User Label, the Sources and Targets will be sorted and displayed in alphabetical order, depending on the fixed label of the Sources/Targets.

Sort by User Label: The Sources and Targets will be sorted and displayed in alphabetical order, depending on the User Labels of the Sources/Targets.

To select the sorting method, choose the 'fixed label' or 'user label' option button as shown below:



Tip The most useful sorting method is to Sort by 'fixed label'.

4.4.2.5.2 View the Different Label Types

It is typical that a user will work in a single mode of label type display within the GC. There are times, however, when it is useful to temporarily display another of the label types globally within the GC to help with patching. The Label mode is changed by clicking on the 'Label' button in the system toolbar:



Clicking this button will toggle the label view globally throughout all parts of the GC. The label display can be toggled between FIXED, USER and Inh /Dev (Inherited/Device).

For a detailed description of how to work best with labels, see below.

4.4.2.6 Working with Labels

For a detailed description of different label types, please refer to [chapter 4.3.3](#).

The most important aspect of any audio patching system is its labeling. Clear labeling allows fast navigation and fault-free patching.

Labels exist within the general patch window as well as within each single channel. Depending on your preferred way of working, some of the label fields may be filled in automatically by the system (by setting some options), or you choose to type the labels manually in all the places. Two principal automatisms for automatically copying labels exist within your system:

- 1 Your studio device names (devices connected to a specific console input) may be filled in automatically into the General Patch window after you made a new title, or recalled a snapshot or preset. These labels are then read from a file saved centrally. So you can change your studio wiring, only having to update one file, and then seeing your updated wiring even when opening former projects.
- 2 The labels within your channels may be filled with the names of connected sources, copying labels from the source to the channel whenever a patch point is set, cleared, or changed.

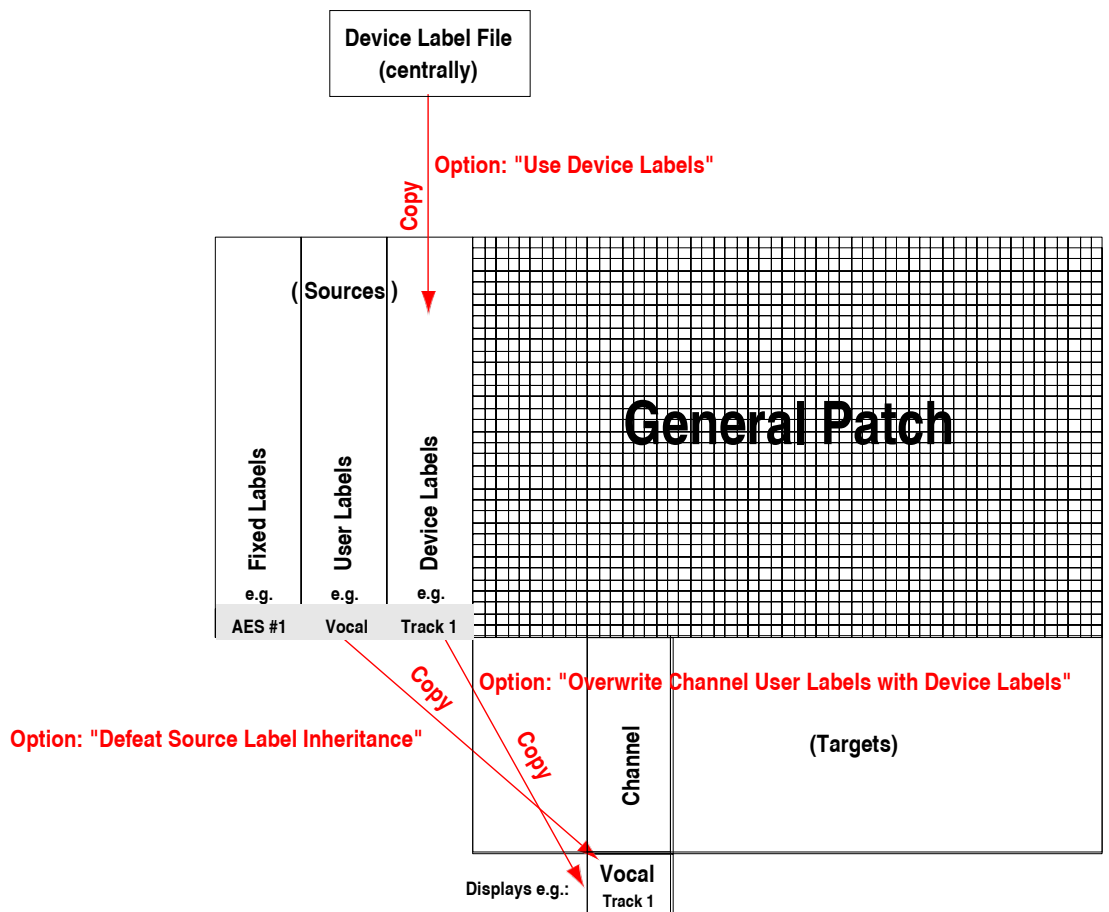

Note: The 'Defeat Source Label Inheritance' option is normally not activated. The other two options may vary, depending on your preferred way of working. In principle, you can select to work according to one of the two methods described below.

4.4.2.6.1 Automatic Label Propagation

The philosophy on Vista consoles concerning labeling is not to name any labels *within channels*, but to name *patch sources* in the General Patch, letting the system propagate them to the connected channels. Specifically, we are talking about two kinds of labels which will be propagated in this way: Device labels (technical labels), and User labels (session labels, e.g. track sheet). This also supports the workflow, whereby the operator first names his sources and then patches them to any possible channel.

Advantages: If a source is connected to more than one channel, or if a patch is changed, the labels are correctly updated on the actually patched channels. You see what you hear!

Change View by Clicking on Label Type Button in the GC's Toolbar

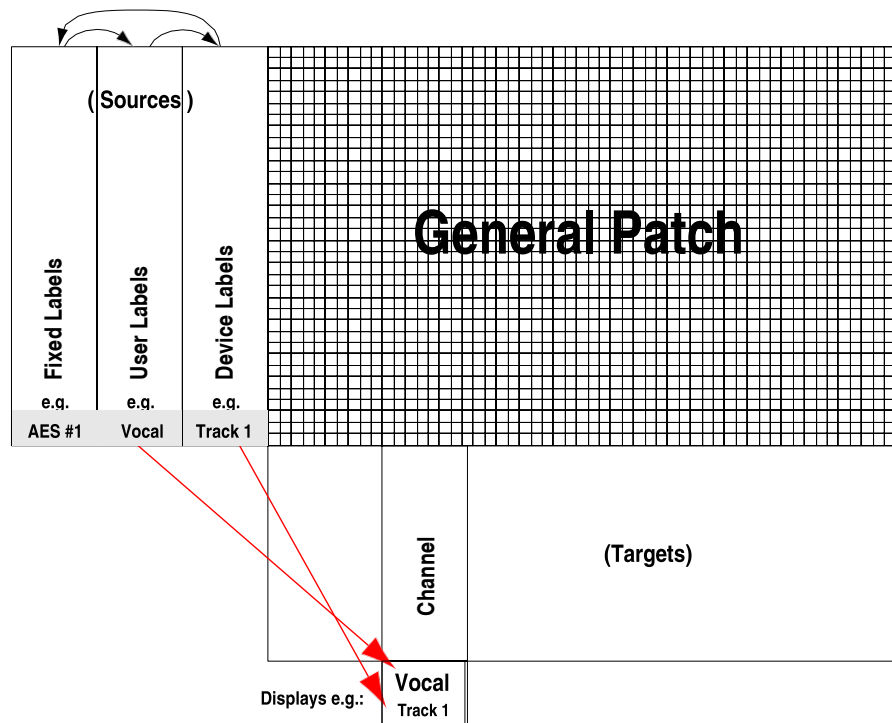

How to Proceed:



- Switch *on* the 'Use Device Labels' option in the Settings/Device Labels menu. (Whilst being logged in as Sysadmin)
- Switch *on* the 'Overwrite Chan. User label with Device Label' option in the Settings/Device Labels menu.
- There must be a file '`DeviceLabels.pre`' present, which holds your device labels (technical labels), e.g. 'Studio 1', 'Mic 1').
- Type your track sheet as User Labels of Input Ports into the Source List of the General Patch.
- Patch Sources to Channels, and you will see session labels displayed in the top line of each channel. You may have to press the GLOBAL VIEW: LABEL TYPE key until you see the device labels or the fixed channel labels in the second line.

This may look as follows:

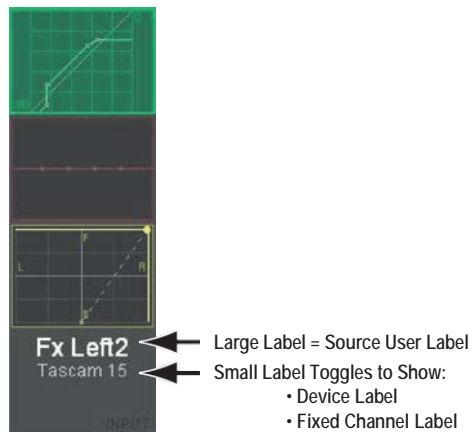

Note In the Strip Setup window it is possible to display either the session labels (standard) or the device labels, depending on the option selected in the lower right corner of the window.



4.4.2.7 What are Device Labels?

All labels shown in the general patch and within the channel strips are always saved together with all audio settings within snapshots and presets. Some of the labels you will name in the patch will most likely represent your studio environment and where your equipment is connected to the console. E.g. you might possibly want to label the AES/EBU input 30 as 'Tascam 11', in order to recognize that you have connected your recorder that way. Since these labels are contained within each snapshot or preset, it is theoretically also possible to change the labels just by recalling a snapshot. In some cases this may be very useful (e.g. if you have entered a track sheet, but would like to use a different one for your next song), but in some cases this can be a handicap: E.g. you change your studio wiring slightly, e.g. add new equipment, but still want to use some of your older project settings. This would lead to the fact that you would have to update all the old snapshots and presets. The same handicap applies if you start with a new title. You will most likely want to see your equipment names appear in the patch automatically. This is where the device label functionality comes up. We have one file holding your device labels (such as 'Tascam 11' for the AES/EBU input 30), and the system is able to automatically read these labels from that file and apply it to your current General Patch screen.

4.4.2.8 How to Activate the Device Label Functionality

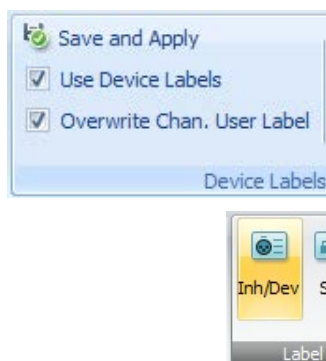

In order to activate the automatic import of your device labels from the device label file, two conditions must be met:

- There must be a preset file named '`_DeviceLabels.pre`' matching the currently loaded configuration and holding your device label names.
- The 'User Device Labels' option in the Settings/Device Labels menu must be activated.

This will automatically show the device labels in the General Patch window when switching to the corresponding label mode.

4.4.2.9 Where are the Device Labels Saved?

As you know, these labels are normally not changed for a specific session, but will stay constant in a studio installation. This is why they are saved in a preset (`*.pre`) file, being valid for the currently loaded configuration, rather than just a snapshot or title. If a different configuration is loaded, you will need to import the '`_DeviceLabels.pre`' file from the previous configuration.

4.4.2.10 How to Create or Overwrite a Device Label

If you create a device label file from scratch or overwrite an existing one with a new one, you may proceed as follows:

- Enter the device labels into the USER LABEL field of the patch (input ports and output ports). *Do this in the USER LABEL field.*
- Enter SysAdmin mode.
- Go to the Settings/Device Labels menu and select 'Save and Apply User Labels as Device Labels'.

4.4.2.11 How to Edit an Existing Device Label

Since the device labels are saved in a regular preset file, you just log in as the system administrator and recall the '`_DeviceLabels.pre`' file. You will see the device labels again in the patch (USER LABEL field). Now you may edit them; then either click UPDATE, or go to the Settings/Device Labels/'Save and Apply' menu.

4.4.2.12 Background Information

If you are using the device label functionality (option Settings/Device Labels/Use Device Labels), you activate an automatic and repetitive import of these labels from the '`_DeviceLabels.pre`' file into your patch. If you create any snapshots, the current device labels will be part of the snapshot. However, if you recall older snapshots that have been saved at a time when no device labels were active, that snapshot on the disk will not be changed at all. The snapshot will be loaded onto your console, visualized as it was saved in your General Patch screen; but an instant later the current device labels of your console will be copied into your patch. If you now choose to update your snapshot or make any new ones, these will contain exactly the labels you see on your General Patch screen.

4.4.2.13 Automatic Generation of Intelligent Fixed Labels

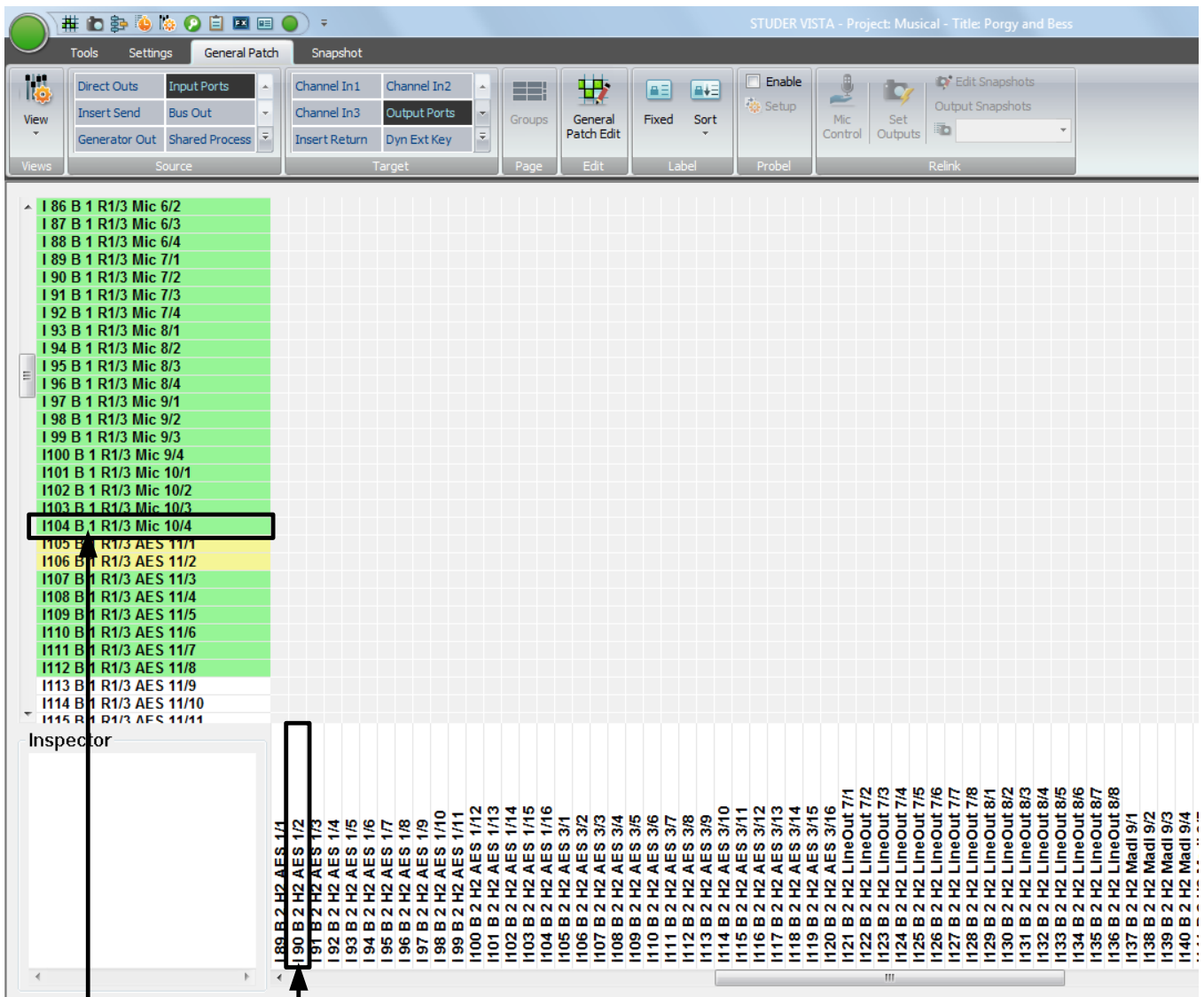

AES input 2 (out of 16) of I/O card 1 inserted in Hub 2 (COM port 2)
 Audio is transferred over HD link channel #90, connected to DSP card #2

Mic input 4 (out of 4) of Mic/Line In card 10 (slot 10) inserted in Remote I/O Box 3 (slot 3), connected via MAD1 to Hub 1 (COM port 1)
 Audio is transferred over HD Link channel #104, connected to DSP card#1

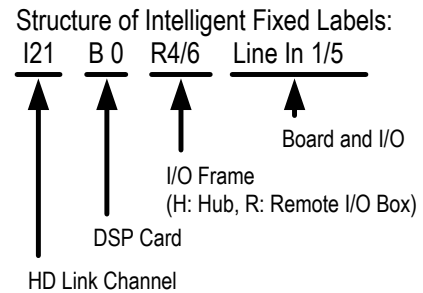

Frame numbers represent double-width slot in corresponding hub frame to which the MAD1 link is connected (1...6).
 Card numbers represent slot number of frame into which the card is inserted.

Audio coming through the D21m I/O components is reaching the core over Studer’s proprietary HD (high density) link in case of the SCoreLive. This link is present between the local hub(s) and the SCoreLive. Each link may carry up to 96 audio channels. Instead of displaying these channel numbers

in the general patch, the software is able to give more intelligent names to the input and output ports shown in the general patch. You will then see frame numbers as well as card types and channel numbers within each card. This generation is automatically active whenever the D21m I/O system is present and the hub frame is connected to the console via a serial link. However, when recalling a snapshot containing the 'non intelligent' fixed labels (e.g. from older productions), this will overwrite the fixed labels as well and make the 'intelligent fixed labels' disappear. In this case, select **Regenerate Intelligent Fixed Labels** within the Settings menu and update this snapshot.

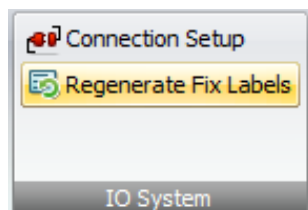

4.4.3 Channel Patch

The Channel Patch page of the graphical controller can be called up in three different ways:

- From the **View** button, by clicking on the appropriate icon
- Using the *Quick Access Toolbar* icons, by clicking on the appropriate icon;
- Using the **CHAN PATCH** function key on the control surface – which is probably the fastest way.

To quickly switch back from General Patch to Channel Patch page, just click the right touch pad button while the cursor is positioned over the X-Y field in the General Patch.

As its name implies, the Channel Patch is channel-oriented, which means that only *one* channel is displayed at a time.

To select a channel to be displayed in the Channel Patch page:

- Press the **LINK/SEL** key on the desired Desk Channel Strip, or
- Use the Channel Selector on the top of the Channel Patch page.

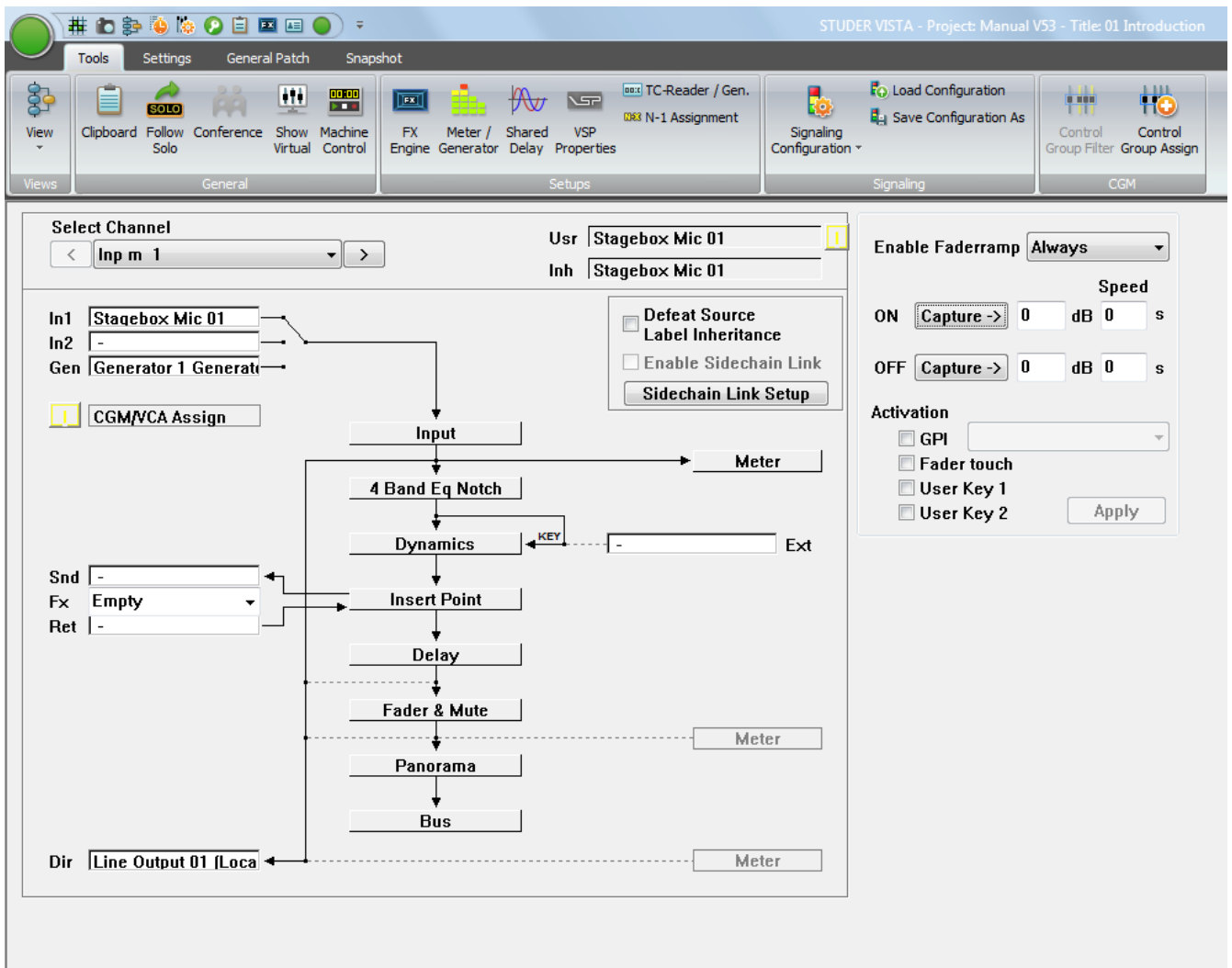

Essentially, the Channel Patch provides a block diagram of the selected channel's audio path. All channel types can be selected. From the Channel Patch, you can:

- View General Patch connections to and from the selected channel;
- Directly access the channel's patch points in the General Patch;
- View channel's DSP processing blocks;
- Set the order of DSP processing blocks in the selected channel's audio path;
- Toggle three-way input selector of the selected channel;
- Toggle selected channel's two-way Dynamics key selector;
- View and edit selected channel's Desk Labels;
- Switch off selected channel's Label Inheritance function;
- Set the Metering source point in the selected channel's audiopath;
- Set the Direct Output source point in the selected channel's audiopath;
- Setup the Sidechain Links;
- Activate the Sidechain Link for the selected channel.

4.4.3.1 Using the Channel Patch for Patching Audio

The Channel Patch page displays the following channel-oriented patch items of the selected channel for viewing:

| | |
|------------------|-----------------------------------|
| In1 | The first audio input; |
| In2 | The second audio input; |
| Gen (In3) | The third audio input; |
| Snd | The Insert Send; |
| Ret | The Insert Return; |
| Ext | The key signal to Dynamics Block; |
| Dir | The Direct Out. |

These labels will be displayed according to the current Label Mode. To edit the patch connection, just double-click the left touch pad button while the cursor is positioned on a connection. This will toggle over to the General Patch page, allowing actions to be performed. The connection you pointed at will be pre-selected automatically.

Examples for channel Im1 (Input Mono 1):

*Double-click on **In1** field*

- toggles to General Patch
- pre-selects Target Im 1 Input m 1 In1
- now only select a Source and patch it.

*Double-click on **Dir** field*

- toggles to General Patch
- pre-selects Source Im 1 Input m 1 DirOut
- now only select a Target and patch it.

Obviously, if the connection you selected is a Source (Snd, Dir), you will only have to select a Target in the General Patch. If the connection is a Target (In1, In2, Gen, Ret, Ext), you will only have to select a Source.

All patch cross-points are saved with snapshots and presets.

 **Tip** To quickly toggle the display from Channel Patch to General Patch page, just click the right touch pad button while the cursor is positioned anywhere in the Channel Patch page.

To quickly switch back from General Patch to Channel Patch page, just click the right touch pad button while the cursor is positioned over the X-Y field in the General Patch.

4.4.3.2 Setting the Order of DSP Processing Blocks

The following processing blocks (if available in the currently selected configuration) can be placed individually at different locations along the Audio Path of the channels:

- EQ;
- Insert Point;
- Dynamics (Compressor/Limiter/Expander/Gate/Sidechain);
- Delay;
- Fader & ON/OFF Mute.

The actual order of the system blocks is user-modifiable, and can be changed at any time. The order is saved with snapshots and presets.

To change the system-block order, use the familiar drag-and-drop technique:

- Click on the selected blocks, and hold down the touch pad button;
- Available positions in the signal path are shown as a *reversed embossed graphic*;
- Drag the selected block to the required position in the signal path;
- If the block can be inserted at that location, the block name will turn *red*;
- Release the button and the selected block will be inserted into the new location.

4.4.3.3 On-screen Toggles for Input Selector and Dynamics Key Selector

- | | |
|------------------------------|--|
| Input Selector | To toggle the three-way input selector (In1, In2, Gen), click on the switch icon that corresponds to the location at which you want the selector to point. The Desk Input Selector keys will follow the changes, and display the correct source. |
| Dynamics Key Selector | To toggle the two-way input selector (Int, Ext), click on the switch icon that corresponds to the location at which you want the selector to point. |

The selector settings are saved within snapshots.

4.4.3.4 Editing the Channel User Labels

Double-click on the user label field (Usr) to open the Edit window. Proceed to edit and/or change the Desk Label using the same techniques used in the General Patch.

4.4.3.5 Set the Metering and Direct Out Source Point

Set Metering Source Point: To set the Metering Source point in the selected channel's audio path, click on one of the three Meter boxes. The channel meter will now be sourced from the selected point in the signal path.

Available points in the signal path are:

- After Input Block;
- After Fader & Mute;
- After Direct Out level control.

The Meter Source point is saved within snapshots and presets.

Note: There will only be two Meter Source points if Direct Outputs have not been configured for the selected channel.

To set the Metering Source points for more channels at a time, use the Tools/Meter/Generator menu (refer to [chapter 4.6.1.2.2](#)).

Set Direct Output source Point: If a Direct Output is included in a channel's configuration, it can be fed from one of three points in the audio path. To set the Direct Output source point, click on one of the three 'wires' connected to the Dir Box (the current connection will be shown *solid*, while the two possible connections are displayed as *dotted* lines).

The Direct Out will now be fed from the selected point in the signal path.

Available points in the signal path are:

- After Input Block;
- Pre Fader & Mute;
- After Fader & Mute.

The selected Direct Output source points are saved within snapshots and presets.

 **Tip** If you have changed the order of the processing blocks, note that the Meter and Direct Out source points will move *together* with the processing blocks to which they are attached (except the Input Block, which cannot be moved).

4.4.3.6 Switch off the Label Inheritance

The Desk Label displays will show Source Labels (from the General Patch) if the console is set to Inherited Label mode and if a source is patched in to the channel. If you wish to remain in Inherited Mode, but do not wish to see Source Labels for certain channels, check the Defeat Source Label Inheritance box. The Desk Label display will now show the name of the channel rather than the Source Label, assuming the user label on the Channel Patch has not been changed from the default. If the user label has been changed on the Channel Patch screen, the Desk Labels will display this user label when the Defeat Source Label Inheritance box has been checked. user labels entered on the Channel Patch screen are saved with snapshots and presets.

4.4.3.7 Setup & Activate the Dynamics Sidechain Link

The effect of a Dynamics Sidechain Link, if activated, is identical to any item of outboard gear set to Link or Stereo mode. This function is used to control between two and eight Dynamics Processors inserted into up to eight different channels. Regardless of which channel is carrying the highest signal level, all processors will provide the *same* gain modification. In this way, Stereo or Multi-channel Surround image stability will be preserved. Unlike in many analog consoles with dynamics units, the channels to be linked do not need to have adjacent locations.

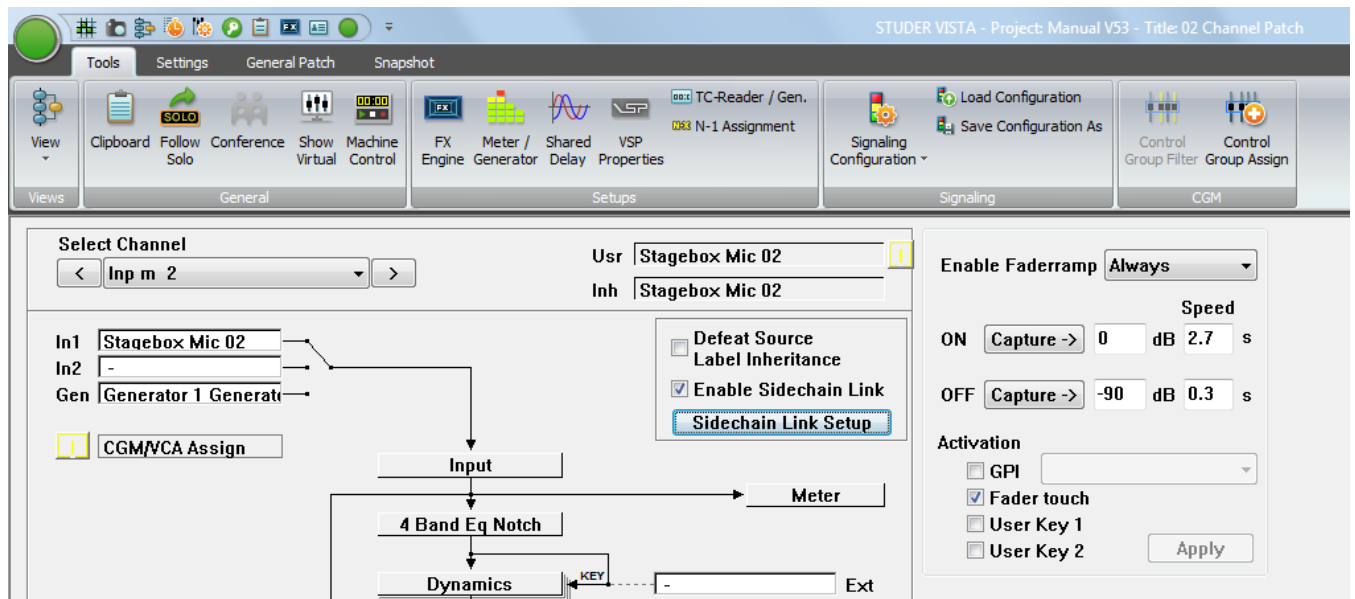

Note: The number of Sidechain Links available (if any) is determined by the currently loaded configuration.

To activate the Sidechain Link for a selected channel, check the Enable Sidechain Link box. This will activate linking of the Sidechain with another channel, or with other channels assigned to that particular Link Group. The channel must be assigned to a Link Group in order for the Enable Sidechain Link box to function. The SCL (Sidechain Link) keys on the Vistonics will follow the selections.

The status of the Sidechain Link is saved within snapshots and presets.

Sidechain Link Setup: Click on the Sidechain Link Setup button to bring up the Sidechain Link editor screen, which allows selecting available links and adding/removing of channels to/from the links.

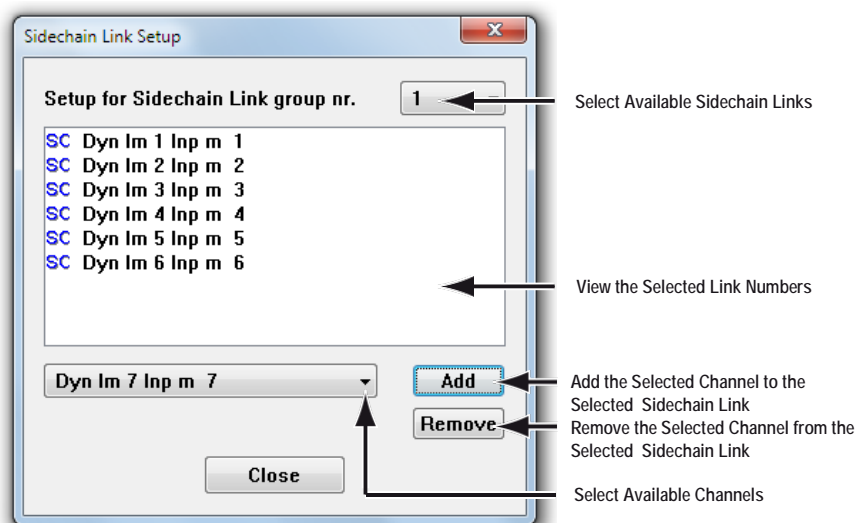

Vista is able to link more than only two side chains – in fact, up to eight – per Sidechain Link. For these reasons, a number of Sidechain Links (each for up to eight member channels) may be defined by the currently loaded configuration. Basically, there can be any number of configured Sidechain Links. A channel can be a member of only *one* Link at a time.

To set up the Sidechain Links:

- Select a Sidechain Link using the on-screen icon;
- If there are any members in the Link, they will now be displayed;
- Add new member channels with the Add button;
- Remove members by selecting one or more of them in the list and pressing the Remove button;
- Proceed to edit the next Link number.

Tip If a channel is a member of a Sidechain Link, the graphical representation of its dynamics block in the Channel Patch will change from this

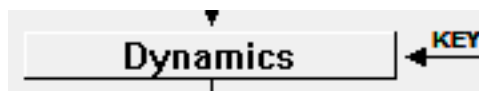

to this:

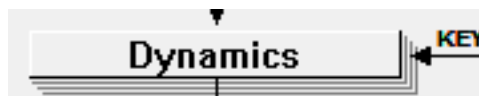

4.4.3.8 Fader Ramp Control ('Audio Follows Video')

The screenshot shows the channel patch window for 'Stagebox Mic 02'. The signal flow is as follows: Input → 4 Band Eq Notch → Dynamics → Insert Point → Delay → Fader & Mute → Balance → Bus. The 'Fader Ramp' control panel on the right is highlighted with a black border. It includes the following settings:

- Enable Faderramp: Always
- ON: Capture → 0 dB, 2.7 s
- OFF: Capture → -90 dB, 0.3 s
- Activation:
 - GPI: H1 Gpio 13 01
 - Fader touch
 - User Key 1
 - User Key 2

Faders of all console channels can be externally controlled. When using this feature, the console operator determines the Fader Open/Close values, as well as the fade in/out speed. Various triggers are available in order to activate the fade. The channel patch window allows adjustment of all necessary settings. The fader ramp function might be particularly useful when doing TV work. Opening and closing of certain microphone channels may be controlled by the video switcher, using GPIs (general-purpose inputs, i.e. closure contacts in the monitoring rack). Another possible use is radio/TV talk-shows: Different people have their microphones constantly opened and lowered. This action may be pre-programmed, and the fade in/out may be activated by just touching the fader or pressing one of the **USER** keys. The following options may be set in the channel patch window:

Enable Fader Ramp: Select if you want to use one of the two **USER** keys to enable the fader ramp on a specific channel. It is also possible to activate it constantly, leaving the **USER** keys free for other functions.

ON (Fader Value): Clicking on the **Capture** button will set the current fader value to be used when the GPI is active, hence the value used when the fader is opened. Alternatively the value may be typed using the keyboard or by using the touch pad: Click in the number field and drag the pointer up or down. This action is similar to the way time values are adjusted in the dynamic automation of the Vista consoles.

OFF (Fader Value): Clicking on the **Capture** button will set the current fader value to be used when the GPI is inactive, hence the value used when the fader is lowered/closed. Alternatively the value may be modified as described above.

Note: By using the same GPI on two channels and setting the ON value to the 'fader closed' position on one of the two and vice versa allows using one GPI to

OFF (Fader Value): Clicking on the **Capture** button will set the current fader value to be used when the GPI is inactive, hence the value used when the fader is lowered/closed. Alternatively the value may be modified as described above.

Note: By using the same GPI on two channels and setting the ON value to the 'fader closed' position on one of the two and vice versa allows using one GPI to control opening *and* closing of different channels at the same time.

Speed ON: Determines the time used for fading in the corresponding channel.

Speed OFF: Determines the time used for fading out the corresponding channel.

Activation: The fade actions may be activated by different events. Several events may be enabled at the same time. The fade will take place whenever one of the activated events is detected:

GPI: Select one of the general-purpose inputs available on the console for triggering the fade.

Fader Touch: Touch-and-release the fader in order to activate the fade.

Note: If the fader is moved while being touched, no automatic fade is being executed. This prevents from accidental fading.

User Key 1/2: The fade is activated when pressing the corresponding **USER 1** or **USER 2** key on each channel.

Note: In case adjusted values should constantly jump back to their previous values, check that the `C:\D950System\Sig...ini` file is not write protected.

4.4.4 Snapshot Page

The snapshot page of the graphical controller can be called up in three different ways:

- From the **View** button, by clicking on the appropriate icon
- Using the *Quick Access Toolbar* icons, by clicking on the appropriate icon;
- Using the **SNAPSHOT** function key on the console – which is probably the fastest way.

The snapshot page deals with snapshot and preset management. Snapshots and presets are extremely helpful when working with a digital console as they contain the static values for all console parameters. The difference between snapshots and presets is simple: While snapshots can be edited freely, presets are accessible for editing in system administration mode only (refer to [chapter 4.7](#)).

Snapshots are saved within titles, and presets are provided with configurations. Because of this, snapshots are readily available only while using the title in which they were created. On the other hand, all presets that were created for a particular configuration are available in any title that uses that configuration. This allows presets to be used as templates (based upon that configuration), while snapshots are specific to individual projects or sessions. Another difference between snapshots and presets is that any filtering mechanism is active for snapshots only, but not for presets. This means that after having recalled a *preset*, the user can always be sure to have *all* audio settings of this preset applied.

Using the Import facility from the Application menu, it is possible to use snapshots and presets from other titles and configurations, refer to [chapter 4.5.4](#).

Because it is possible to save an *unlimited* number of snapshots, Vista operators will probably find themselves using them more and more every day.

A snapshot or preset will save:

- All audio settings: Fader levels, auxiliary settings, dynamics, delays, input selectors, etc.
- Order of channel processing blocks;
- Direct output and meter source points;
- Bus assignments;
- All labels;
- All patch cross-point connections;
- Channel and other links;
- N-1/mix-minus assignments.

 **Tip** Snapshots and presets always save *every* control and switch setting for the *entire* console. The choice of recalling every setting to every control is up to the operator. A sophisticated filtering system is available in order to keep certain settings even when recalling a snapshot.

4.4.4.1 Snapshots

To capture a new snapshot of the various user controls, press the MAKE SNAPSHOT key on the console:

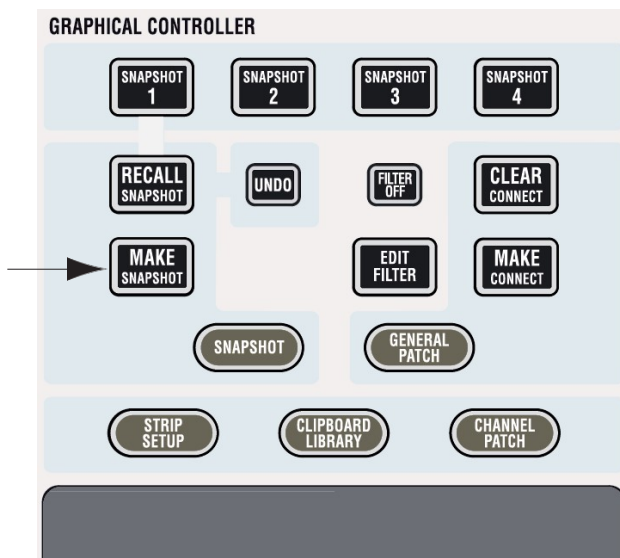

The new snapshot will automatically be numbered like **SNAPSHOT #1**, **SNAPSHOT #2**, etc.

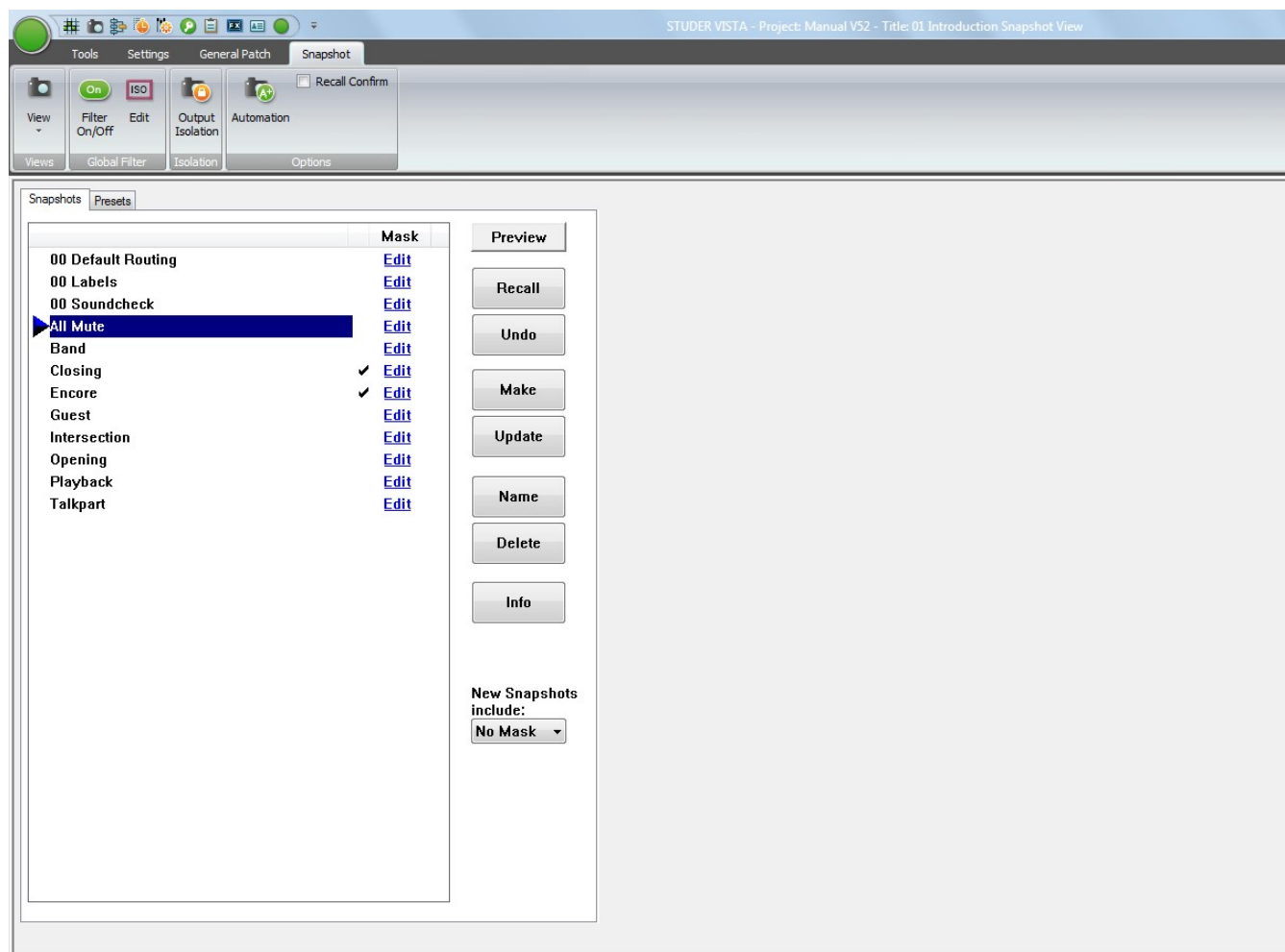

Now You Can: Recall a Snapshot

- Select a snapshot from the List, and
- click on the **Recall** button, or
- simply double-click on the snapshot you wish to recall.

Clicking on the Next button will recall the currently selected snapshot, move down by one row in the snapshot list and recall the next snapshot. The snapshot that was recalled last is marked with a small triangle. If the 'Recall Confirm' option in the Snapshot menu (refer to [chapter 4.4.4.11](#)) is checked, there will be a pop-up dialog requiring confirmation of snapshot Recall. This capability is useful for live environments, where you may not wish to delete or overwrite too easily what you are doing.

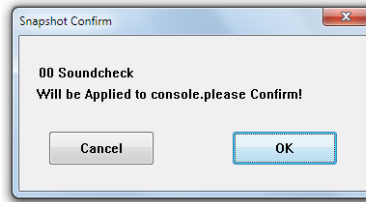

Note: Once a snapshot or preset is applied, the existing parameter settings are replaced by those contained within the snapshot or preset. If the previous settings had not been saved, there is an **Undo** button available, in order to go back to the last settings before recalling the snapshot or preset. This has to be confirmed as well if the 'snapshot Confirm' option in the Options menu is active, as mentioned above.

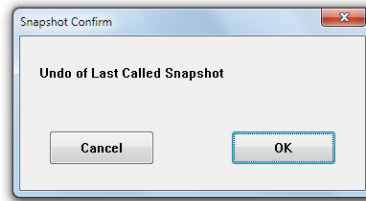

Snapshot Preview

If you are not completely sure whether the selected snapshot is the right one, click on the **Preview** button. Its colour changes to pink, and the Vistonics screens indicate the parameter values of the selected snapshot, next to the current values, in pink as well - as shown below for some mono Aux levels:



(Re-) Name a Snapshot

- Select a snapshot from the List, and
- Click on the **Name** button.

This action will bring up a window that allows the user editing this snapshot's name. Since snapshots are listed in alphabetical order, by carefully naming you can arrange them exactly as you wish.

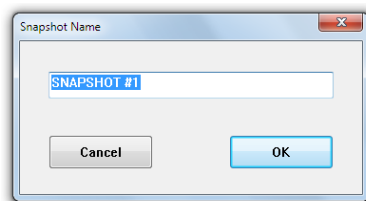

Update a Snapshot

- Select a snapshot from the List, and
- Click on the Update button.

This action will bring up a window that allows the user to confirm the update. An update will save any changes you since made under the selected snapshot's name.

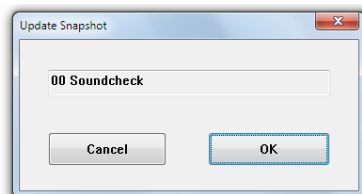
***Delete Snapshot(s)***

- Select a snapshot from the List, or
- Select any number of snapshots from the List using the familiar Windows multiple-selection techniques (press **Shift** and select the first and the last snapshot with the touch pad pointer, or press **Ctrl** and select whichever you desire with the touch pad pointer). A click on Delete will bring up a window to confirm the deletion.

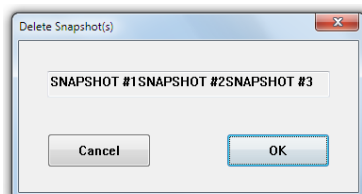
***View the Snapshot Info***

- Select a snapshot from the List, and
- Click on the Info button. This will bring up a window displaying the snapshot Name, the snapshot Creation Date & Time, and the snapshot Last Modification Date & Time.

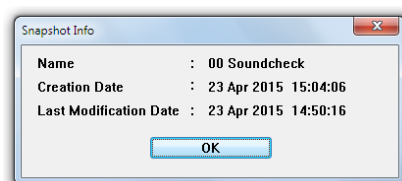

Note Snapshots are saved with the current title; their file extension is ***.snp**.

4.4.4.2 Multiple Snapshots

Updating Multiple Snapshots Very often, certain parameters should be overwritten in multiple snapshots. It may be important that only certain parameters are overwritten and others are left as they are in the individual snapshots. In order to achieve this, place those parameters into 'Isolate' mode and recall a snapshot. If this action is now followed by an Update command, the values are changed as requested. By using Trim mode (see [chapter 4.4.4.7](#)), it is even possible to apply relative changes to individual parameters of snapshots. E.g. place the fader 1 into Trim mode and lower it by 8 dB. Recall the next snapshot and click Update. This will save the original value of the second snapshot, reduced by 8 dB, to the hard disk. See example #2 below for details.

This can be done even faster: First select multiple snapshots and click Recall and Update once.

Note The **Update** button is changing its name whenever multiple snapshots are selected.

Selecting Multiple Snapshots

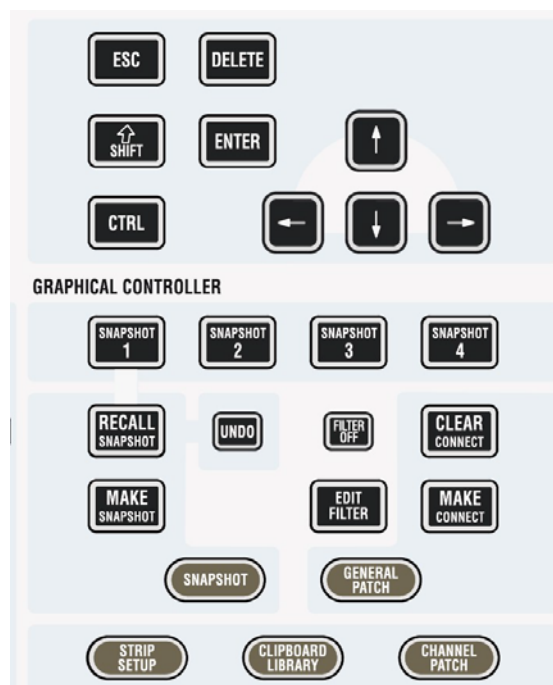

Multiple snapshots can be selected simultaneously by using the keyboard \hat{u} SHIFT and CTRL keys. The selection of multiple snapshots is following standard windows rules: \hat{u} SHIFT + click selects all snapshots in between the two, CTRL + click allows selection of individual snapshots.

Example 1

Goal The value of channel 3 should be overwritten and set to -20 dB on 'snapshot #1', 'snapshot #3', and 'snapshot #5'

Procedure Place the fader to -20 dB.

Hold ISO on channel strip 3. Touch the fader in order to put it into isolate mode.

Select 'snapshot #1' with the touch pad.

Hold the CTRL key on the control bay, and select 'snapshot #3' and 'snapshot #5'.

Click on 'Recall and Update', and confirm that you want to overwrite these snapshots.

The console will automatically recall and update the selected snapshots.

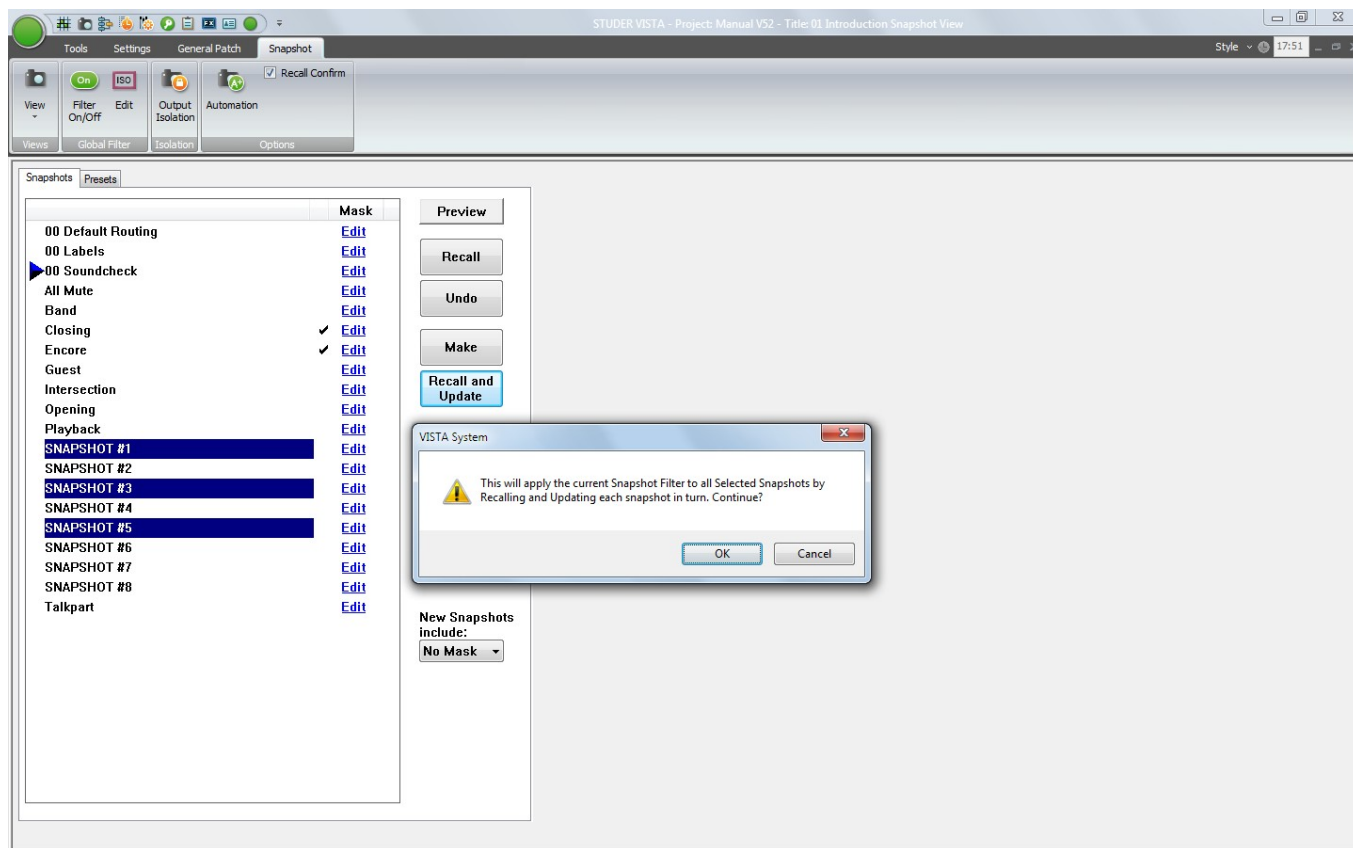

Example 2

Goal The value of channel 3 should be reduced by 4 dB on 'snapshot #1', 'snapshot #3', and 'snapshot #5'.

These snapshots currently contain the following fader values:

'snapshot #1': 0 dB; 'snapshot #3': -5 dB; 'snapshot #5': -10 dB.

Therefore, after the update they should contain the new, updated values:
'snapshot #1': -4 dB; 'snapshot #3': -9 dB; 'snapshot #5': -14 dB.

Procedure Make sure the **Enable Trim mode** option in the 'Option: snapshot Automation' menu is set.

Recall any snapshot.

Hold ISO on channel strip 3. Touch the fader *twice* in order to put it into Trim mode.

Lower the fader of channel 3 by 4 dB (the exact trim value will be displayed on the Vistonics screen).

Select 'snapshot #1' with the touch pad.

Hold the CTRL key on the control bay, and select 'snapshot #3' and 'snapshot #5'.

Click on 'Recall and Update', and confirm that you want to overwrite these snapshots.

The console will automatically recall and update the selected snapshots.

Since the console assumes that the controls being in Trim mode have been placed into this mode for the purpose of this update, the operator will be asked whether these controls should be taken out of Trim mode afterwards.

4.4.4.3 Snapshot Crossfading

In the Theatre CueList, it is possible to define a crossfade time for each cue - and therefore a crossfade time can be applied to a snapshot. This is done by simply clicking on the crossfade time and scroll your touch pad up or down. If the crossfade feature is deactivated (see [chapter 4.4.5.2.1](#)), it is impossible to adjust the crossfade time.

The snapshot crossfading may be deactivated by deselecting the Xfade Active option on the Theatre CueList.

Settings that cannot be crossfaded (switches) can either switch at the beginning, in the middle of the crossfade or after the crossfade. This behavior can be defined in the snapshot Automation Options window selected from the Options menu. There, it is also possible to define a Default Crossfade Time. For an explanation of the Enable Trim Mode option, refer to [chapter 4.4.4.7](#).

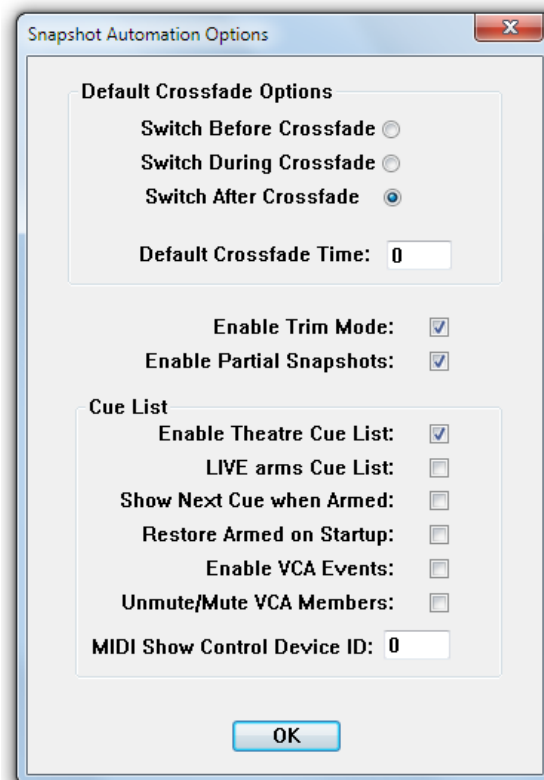

4.4.4.4 Additional Snapshot Functionality

In addition to the dedicated MAKE SNAPSHOT hardware key, there are four SNAPSHOT 1...4 keys for saving and recalling four individual snapshots on these keys.

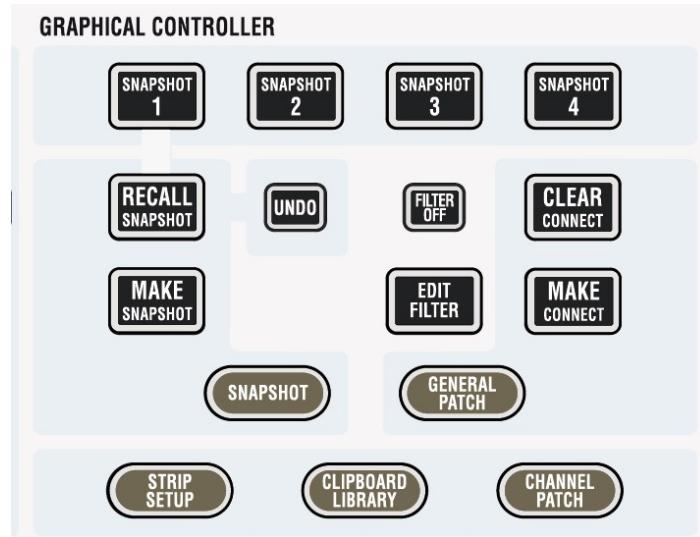
**Assign a Snapshot to a Key:**

To save a snapshot onto one of the 4 keys, *push and hold down* the MAKE SNAPSHOT key, then hit the key you would like it to be saved on. Depending on which of the keys you select, a snapshot will be generated in the snapshot List called `_snapx_key`, where *x* is the number of the selected button between 1 and 4. This snapshot can now be recalled at any time using the dedicated key by *holding down* the RECALL SNAPSHOT key and pressing the desired SNAPSHOT key. The need for a two-key operation provides a certain level of security.

A new snapshot can be applied to one of the dedicated keys even if the button already has a snapshot saved to it. In this instance, the previously saved snapshot will be overwritten.

Tip To ensure that a snapshot that has been saved on a dedicated key is not overwritten, and hence lost from the snapshot list, always make the snapshot twice, once to the key and once in the normal way just by pressing the MAKE SNAPSHOT key by itself. In this case the same snapshot will appear in the snapshot list twice; once called `__Snapx_Key` and a second time as Snapshot *x*. Rename the latter snapshot as required; this will ensure that the snapshot is not lost even if it is removed from the dedicated key.

Note: It is possible to rename any snapshot already existing in the snapshot list to `snapx_key`. Doing this will put the renamed snapshot onto the chosen hardware key directly without having to recall it first. *Make sure that only one instance of `_Snap1_Key`, `__Snap2_Key`, `__Snap3_Key`, or `_Snap4_Key` exists in the snapshot list at any time.*

Snapshot Preview: By clicking on the PREVIEW button, the console enters this mode. Regardless of which snapshot the user selects, *pink* elements within all Vistonics elements will show any difference between the current console settings and the settings within the previewed snapshot. It is still possible to recall any snapshot by all mechanisms described above.

When pressing any of the four dedicated **SNAPSHOT 1...4** keys without pressing the **RECALL SNAPSHOT** key at the same time, that corresponding snapshot is automatically only previewed. It is also possible to preview it only momentarily by pressing e.g. the **SNAPSHOT 1** key for a longer period; the key will be lit as long as the preview is active.

4.4.4.5 Partial Snapshots

It is possible to create snapshots that do not affect the whole console when recalled. They are called ‘partial snapshots’. When recalling such a snapshot, only some of the channels – or even only some of their elements – are being changed on the desk. Partial snapshots are being marked with a checkmark next to the Edit link.

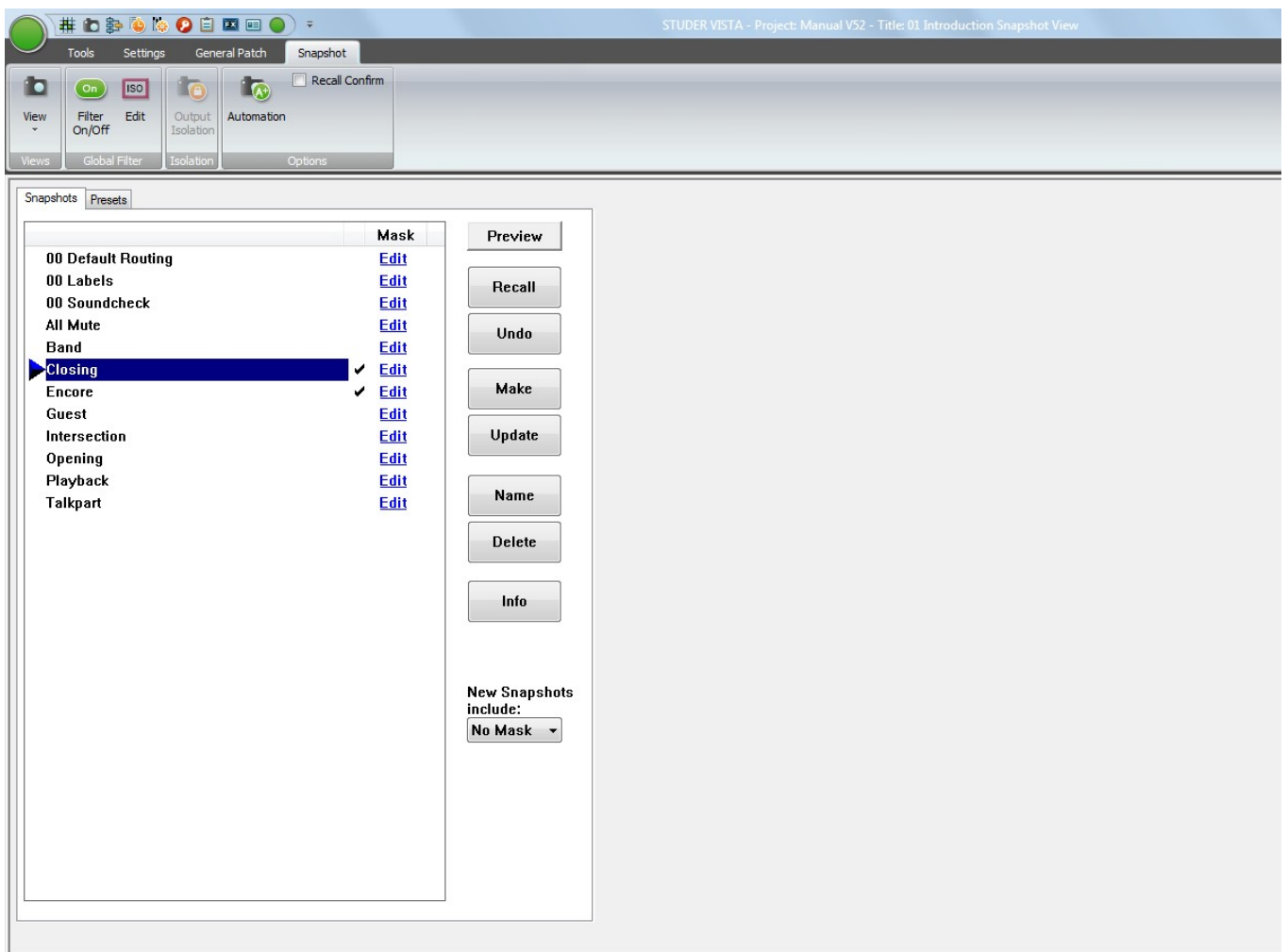

Creating a Partial Snapshot

The easiest way to create a partial snapshot is to gang some channels and make a snapshot, while having the ‘New snapshots include:’ setting set to ‘Gang’:

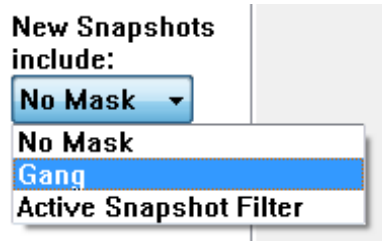

If no gang is present, the whole console settings will be saved in a full snapshot. If the ‘New snapshots include:’ setting is set to ‘No Mask’, there will always be made a full snapshot, regardless of a gang being present or not. It is also possible to set the partial snapshot to ‘Active snapshot Filter’. This will actually create a partial snapshot out of the settings currently *not* masked out by a snapshot Filter.

Saving Snapshot Masks

When working with partial snapshots (option available in Snapshot/Options: ‘Snapshot Automation Options’), it is possible to right-click on the **Edit** link to the right of the snapshots. A context menu will allow not only copying and pasting of masks between snapshots, but also saving and loading of masks to/from files. The files will be saved in the C:\d950System\Users directory.

This function can be very helpful when multiple operators are working on the console. During rehearsals, both operators may randomly save snapshots. After the rehearsal they select ‘their’ snapshots and apply a prepared mask to them. This will make these particular snapshots only influence the part of the console which the operator was working on. Other applications may contain any recall of more complex masks.

Editing Snapshot Masks

If a partial snapshot already has been made and the user finds that he forgot to have some channels in that snapshot, there is a powerful method to correct the mask contained in a partial snapshot. As it has been mentioned at the beginning of this chapter, each snapshot file in general contains all settings of the console. A partial snapshot just adds an invisible mask to the audio settings. Therefore it is possible to enter an edit mode, showing the *mask of a partial snapshot* and giving the possibility to edit it. Let’s say you had channels 1 to 5 in a gang and made a partial snapshot of them, it is easily possible afterwards to tell the system that this snapshot should have also contained the channel 6 data. How to do this?

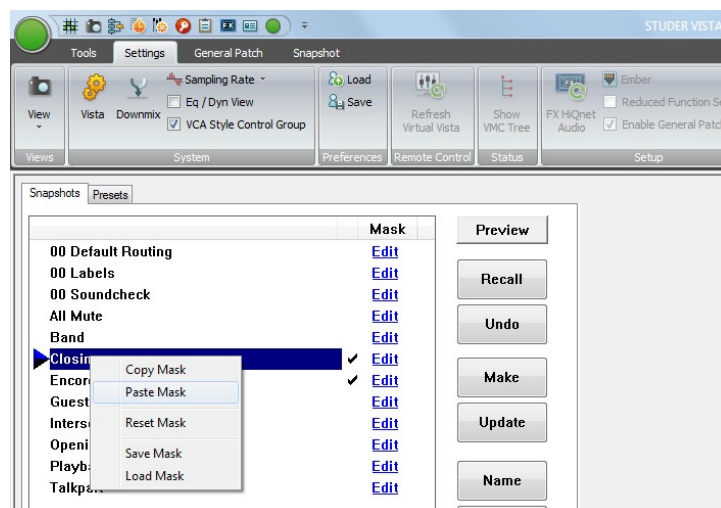

Next to each snapshot there is an Edit link at the very right of the snapshot list. By clicking this button, you will put the console into the 'partial snapshot filter edit' mode. Then you will see the same edit dialog box on the screen as when editing the snapshot filter. Also the desk doesn't show your audio settings anymore, but the mask defining the focus of that partial snapshot. You may now press ISO on one or more channels, create a gang, and add multiple channels to the partial snapshot, or touch and press any other control. The same mechanism will apply as when editing the snapshot filter. Upon clicking the Edit link again, you leave the edit mode, and the console is back to display normal audio settings.

When you are not in the edit mode of the partial snapshots mask, you are also able to copy and paste masks across from one snapshot to one or multiple others. Simply *right-click* on the Edit link of a snapshot mask and use the standard windows commands.

4.4.4.6 Typical Applications

Isolate one or more channels from being changed by upcoming snapshot recalls:

Press ISO on the corresponding channels. The user may create a gang first in order to isolate multiple channels at a time.

Isolate just the EQ of one or more channels from being changed by upcoming snapshot recalls:

Press and hold ISO in order to enter the edit snapshot filter mode, indicated by magenta-colored frames within all Vistonics elements of this channel. *All LEDs will now display their isolation status but not the audio.* E.g. if the EQ button is lit at this time, the EQ is isolated. In order to change the isolation status, press the corresponding key, touch the fader or knob while still holding the ISO key. The word 'ISOLATE' will now show up in the generic display area, indicating that some element is currently isolated. You may also use a gang in order to isolate one element of multiple channels.

De-Activate the whole snapshot filtering mechanism on the console

Press FILTER OFF on the Control Bay, or click on the snapshot filter icon in the toolbar to de-activate the snapshot filtering while keeping its definition for later use.

Create Snapshots, that contain only some of the channels, but not the whole console

Set the 'New snapshot includes:' option to 'Gang'. Whenever a gang is present, only the gang will be 'part of the snapshot'. If there is no gang, the whole console is affected by the recall of freshly created snapshots. A snapshot not affecting the whole channel is graphically marked by a checkmark (☑).

4.4.4.7 Snapshot Filtering (Static Automation)

At the time of recalling a snapshot, there might be a filter active, leaving some console settings unchanged upon recall of any snapshot. Each console parameter can therefore be in one of the following states:

- Isolate (= part of the filter); this parameter will not be influenced by snapshot recalls. Indication: yellow 'I'.
- Read (= not filtered); this parameter may be changed upon recall of any snapshots. Indication: none.
- Trim (= offsets applied to snapshot recalls); any changes since the last snapshot recall will be applied in a relative way to upcoming snapshot recalls. Indication: red 'T'.

There are some different ways to define the parameters to be filtered out.

Note: The static automation system (filtering) *cannot* be active on a console which has dynamic automation available. The decision which functionality is available is made by an entry in a `*.ini` file before the system is re-booted, or by using a special way to boot the system (alternate icon on the desktop).

Channel-Based Masking

You may add whole channels or only parts of them to your mask by pressing the channel strip **ISO** key.

Entering Edit Filter Mode

When you click the Edit snapshot Filter button in the toolbar, you will put the whole console into edit snapshot filter mode. Exit by clicking/pressing the same button or key again. While the console is in edit snapshot filter mode, it is not primarily showing audio settings, but actually visualizing the snapshot filter. Each LED will indicate that this parameter is currently part of the snapshot filter, meaning being filtered out from snapshot recalling. Vistonics elements are indicating a small letter 'I' – Vistonics keys change their color to yellow if they are part of the snapshot filter. E.g. seeing the EQ key lit will indicate that this equalizer is currently part of the snapshot filter including all its parameters. If the key is half-lit, there are some – but not all – parameters of that equalizer part of the snapshot filter. If dark, it indicates that none of the equalizer parameters are part of the snapshot filter. You may make the whole equalizer be part of the snapshot filter or not by pressing its key.

If the console is in edit snapshot filter mode, this is indicated by the opened EDIT SNAPSHOT FILTER window (as shown below); on a Vista console, the Vistonics elements are marked by magenta-colored frames in addition.

Notes It is of course also possible to use ganging in order to add an element of multiple channels to the snapshot filter.
To add a whole channel to the snapshot filter, press the **ISO** key on the channel strip.
Also the copy/paste mechanism works in order to copy selections across one or multiple channels.

Adding a Whole Bus to the Snapshot Filter

In edit snapshot filter mode (as described above), the following window is shown on the GC screen:

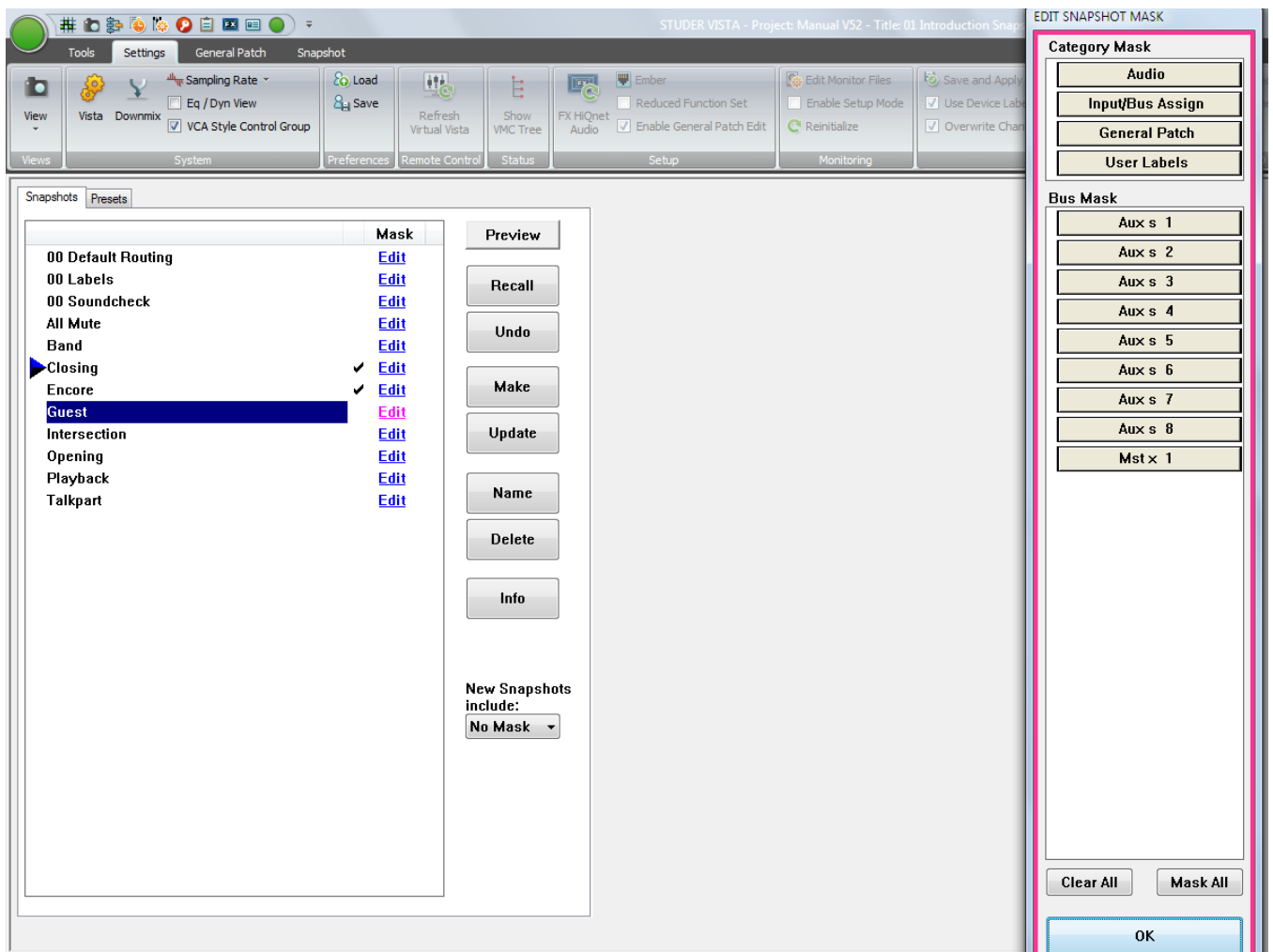

This window allows adding a whole group of parameters to your snapshot filter. Either select one of the four groups on top, or one of the listed busses.

- Audio Settings:** Will add all channel processing functions to your snapshot filter.
- Input/Bus Assign Settings:** Will add the input switches of all channels as well as all bus assignments to your snapshot filter.
- General Patch Setting:** Will add the General Patch to your snapshot filter, meaning that no patch points will change when recalling a snapshot.
- User Labels:** Will add all user labels (within the General Patch as well as within the channel strips) to the snapshot filter.
- Bus:** This is a very powerful feature. By clicking e.g. on ‘Aux m 1’, you will add all relevant parameters to your snapshot filter, such that the Mono AUX Bus 1 will not be influenced by any snapshot recalling. Included are:
- The levels of all channels routed onto that bus
 - The bus assign (on/off switch) of all channels for that bus
 - The corresponding master channel with all its settings
 - The output patch made from that master channel to any output ports.

Caution: Clicking on the ‘Clear All’ button will completely remove the snapshot filter and therefore may change all console parameters upon the next snapshot recall.

Clicking on the ‘Mask All’ button will protect the whole console (with some exceptions, such as Patch points) against snapshot recalls, afterwards allowing to enable just single elements to be activated.

De-activating Snapshot Filters

It is possible to de-activate an existing filter in order to re-activate it at a later point. Click on the corresponding icon in the toolbar to activate/de-activate the current snapshot filter.

If the snapshot filter is de-activated, the icon for entering the snapshot filter edit mode is grayed-out and not accessible.

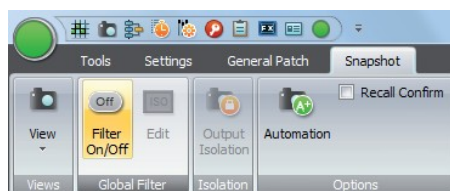

Trim Mode

It is also possible to put elements into Trim mode. In that mode, you may have recalled a snapshot and make some corrections (e.g. push the fader up by some dB). This change will then be applied to all following snapshots when recalling them. This feature is very handy if you have prepared a performance and need to correct some levels when the show really starts. Obviously it is good to have that correction applied to all snapshots of the show.

Note: When going back to Read mode, the elements will jump back to the original snapshot value.

In order to activate the Trim mode as a third possible status of the elements, the Enable Trim Mode option must be activated in the snapshotAutomation Options window. Then the snapshot filter will not only contain two (Read and Isolate) but three modes: Read, Isolate, and Trim. Switches cannot go into Trim mode, therefore their indication is not different (yellow 'I'). However, the rotary controllers and faders will toggle between 'Read', yellow 'I' for 'Isolate' and red 'T' for 'Trim'.

4.4.4.8 Presets

Presets are exactly the same as snapshots. However, they normally can only be recalled but not edited; so their main purpose is to represent – as the name implies – a number of starting console setups that can be recalled, used to build particular refinements from there, and then saved as normal snapshot files.

To access presets from the snapshot page, click on the presets tag. Presets are saved within the configuration, because it is assumed that they may be valid for more than one title.

The file extension is `*.pre`.

If the system administration mode (refer to [chapter 4.7](#)) is activated (by entering the appropriate system administrator password), presets can be edited exactly in the same way as snapshots.

4.4.4.9 Default Settings

In the preset List, there is always one line labeled *defaultSettings*. This is a preset that is automatically generated for every Session Configuration, but no file will be found in the corresponding Session Configuration directory (as would be the case for other presets).

When recalled, the *defaultSettings* will reset the console to the defaults – it functions much like a Total Reset.

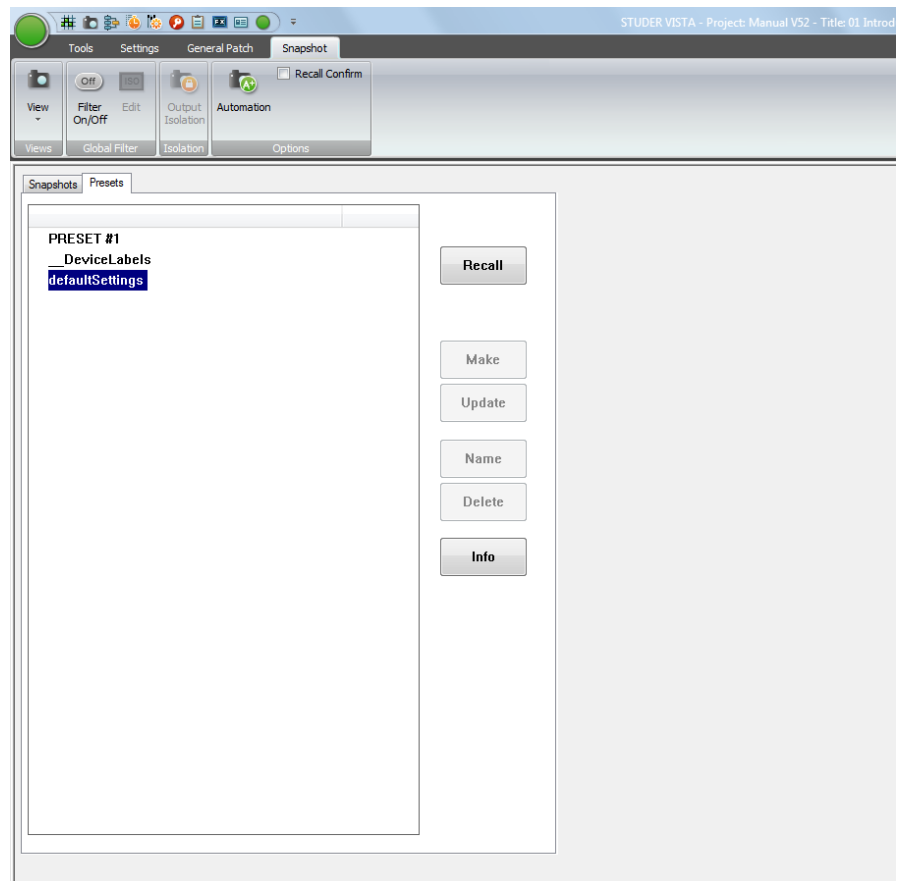

DefaultSettings *cannot* be edited, renamed, deleted or updated.

4.4.4.10 Files and Backup

Snapshots and presets are saved as Windows-compatible files.

Usually, snapshots are saved in the current title directory, with a ***.snp** file extension.

Usually, presets are saved in the Session Configuration directory, with a ***.pre** file extension.

All snapshot and preset files can be copied or moved to and restored from a backup medium using the Make/Restore Backup facility (refer to [chapter 4.5.3](#)).

4.4.4.11 Recall Confirm

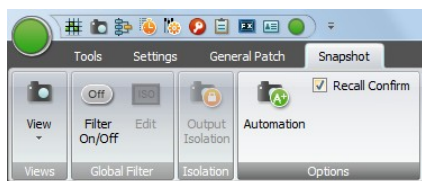

The Snapshot Recall Confirm option can be checked or unchecked:

- If *checked*, the snapshots/presets can only be recalled with user confirmation (the user must click OK or press Enter to finally recall the snapshot/preset, or click Cancel to cancel the snapshot/preset Recall).
- If *unchecked*, the snapshots/presets will be applied to the console immediately, and parameter settings not already saved will be lost.

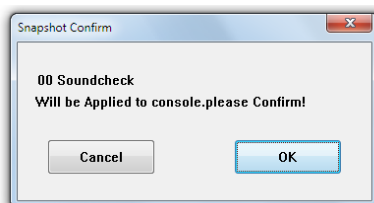

Notes It may be advisable to leave Snapshot Recall Confirm checked until fluency with snapshots/presets is achieved. Snapshot Recall Confirm applies to both snapshots *and* presets.

4.4.4.12 Option: Snapshot Automation

This item allows setting of all parameters for the static, i.e. snapshot automation.

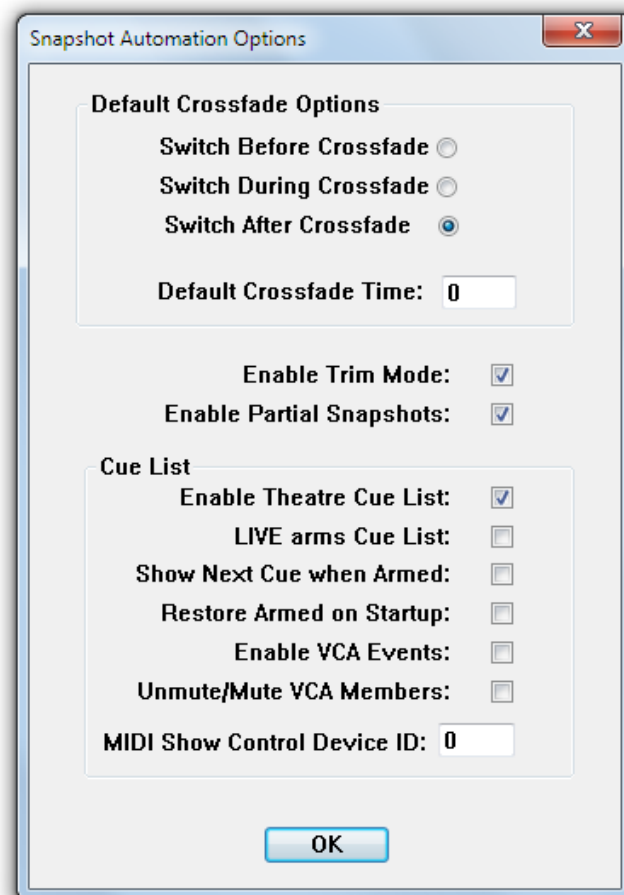

4.4.5 Cue List / Theatre Cue List

Two different cue list functionalities are available that allow sorting snapshots and attaching MIDI, HiQNet and other events to each one of them. Each title can contain only one single cue list. It can be controlled from external controllers using MIDI. It is possible to use standard 'MIDI show control' commands as well as recalling certain cues with a user-defined MIDI command (note or program change). *The Theatre Cue list is only available in 'static' mode, hence not when dynamic automation is active.*

The Cue List page of the graphical controller can be called up in three different ways:

- From the View button, by clicking on the appropriate icon
- Using the *Quick Access Toolbar* icons, by clicking on the appropriate icon;
- Using the CUE LIST function key on the console – which is probably the fastest way.

4.4.5.1 'Standard' Cue List

The screenshot displays the Studer Vista software interface. At the top, there is a menu bar with options: Automation, Tools, Settings, General Patch, and Snapshot. Below the menu bar is a toolbar with various icons for functions like View, Clipboard, Follow Solo, Conference, Show Virtual, Machine Control, FX Engine, Meter Generator, Shared Delay, VSP, TC-Reader / Gen., N-1 Assignment, Load Configuration, and Save Configuration. The main area is divided into three sections: Views, General, and Signaling. The Cue List panel is active, showing a list of cues with their timecodes and names:

| Timecode | Name |
|-------------|------------|
| 00:00:00.00 | __Loc1 Key |
| 00:00:03.10 | Intro |
| 00:00:05.00 | CUE #12 |
| 00:00:15.19 | CUE #13 |
| 00:01:05.16 | CUE #2 |
| 00:01:10.00 | Chorus A |
| 00:01:15.03 | CUE #4 |
| 00:01:20.11 | CUE #5 |
| 00:01:24.16 | CUE #6 |
| 00:01:38.04 | Chorus B |
| 00:02:14.21 | Bridge |
| 00:02:49.16 | CUE #16 |
| 00:03:14.09 | CUE #17 |
| 00:03:32.01 | End |

To the right of the Cue List panel is a Generator panel. It features a 'TC Reader' display showing '00:03:33.24'. Below the display are several control buttons: a left arrow, a right arrow, a play button, a stop button, and a refresh button. The 'From' field is set to 'Intro' with a timecode of '00:00:03.10' and a 'Cues' button. The 'To' field is set to 'End' with a timecode of '00:03:32.01' and a 'Cues' button. There are also radio buttons for 'Play(Loop)', 'Rehearse', and 'Auto Rec.', and two more arrow buttons.

The cue list helps to deal with parts of a musical piece or film you want to keep track of in time. That could be items such as Intro, Chorus A, Bridge, Chorus B, the End of a song, or a scene from the film you might want to (auto-) locate to. An unlimited number of cues can be stored.

Each cue in the cue list has a timecode stamp and a name. The names are generated and numbered automatically when making cues, but may be edited at any time along with the TC stamp. The cues in the cue list are automatically

sorted by increasing TC. If you make a new cue, it will be inserted into the list according to its TC stamp.

When the running TC passes a cue point existing in the list, a small triangle will appear next to the cue to indicate that this particular cue has been reached. The triangle will remain there until the next cue in the list is reached, and so on.

Capture To quickly make a cue (and edit the name and/or timecode stamp later, if necessary), click on Capture in the GC's cue list window when you hear the audio event to be marked:

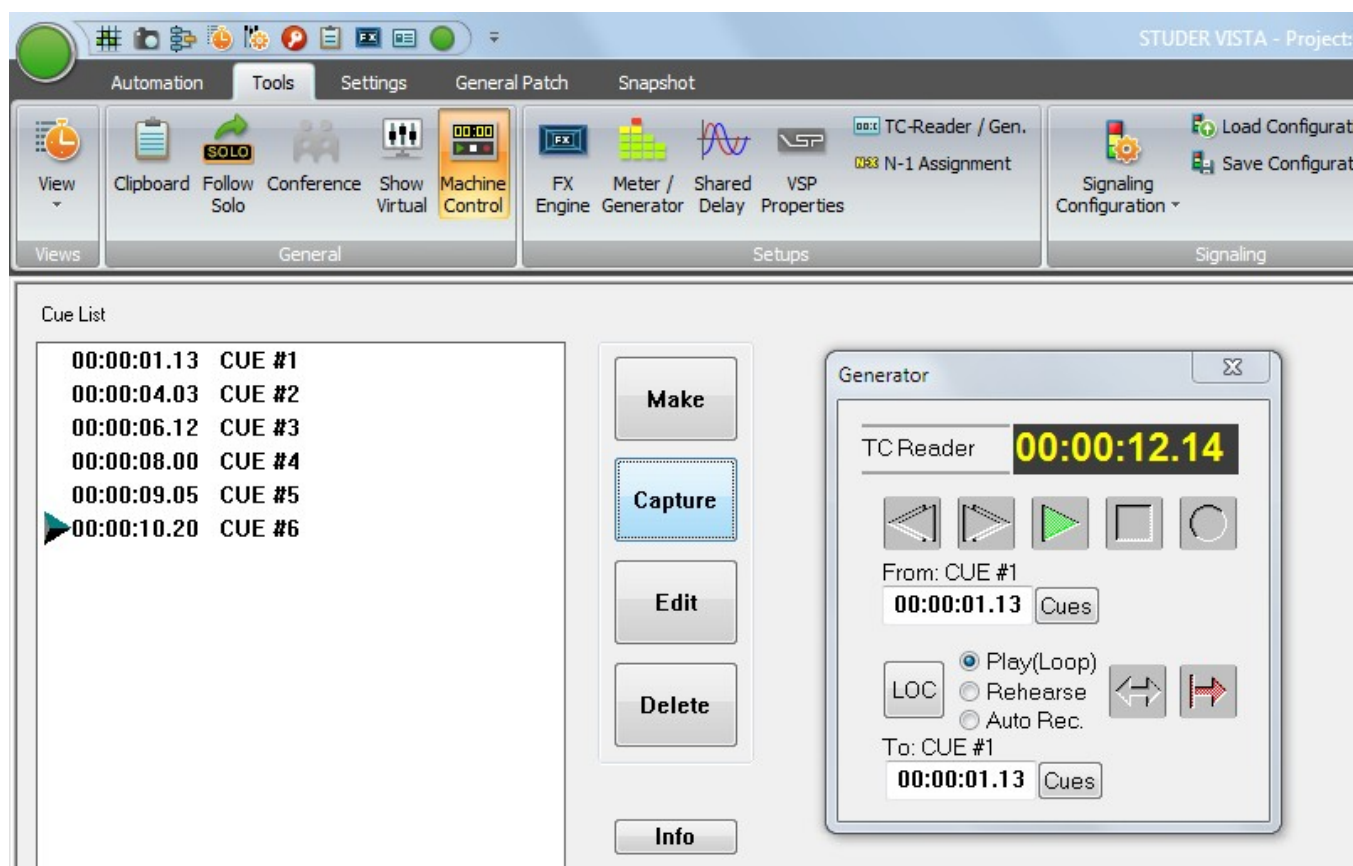

In both cases, a cue point will be generated, automatically numbered, and stamped with the current timecode address at the moment the key was pressed.

Make Making a cue means:

- First enter a name within the edit window that appears when you click the Make button

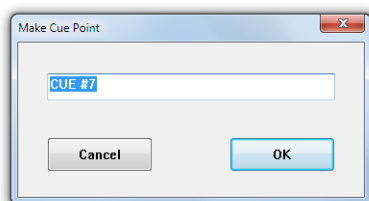

- Wait for the right audio event to occur, and click the on-screen OK button, or press the ENTER key on the desk keyboard

A cue point with the entered name will be generated and stamped with the current timecode as soon as you click OK or press ENTER. You can edit both name and TC stamp later, if necessary.

Edit Opens an edit window that allows changes to be made to the name and the timecode stamp of a selected cue from the cue list.

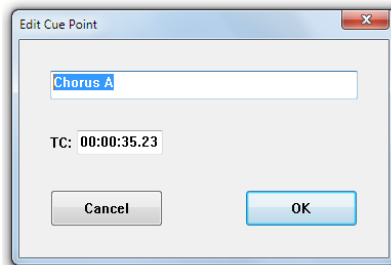

Delete Opens an edit window that allows one or more cues to be deleted from the list. Select a cue in the list by clicking on it, or select any number of cues from the list using the familiar Windows multiple-selection techniques (drag on the touch pad, or press **SHIFT** and select with the cursor). Click on the Delete button. This action will bring up a window asking you to confirm the delete operation.

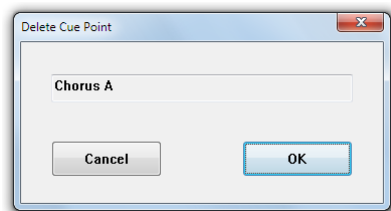

Info Calls up cue info:
Click on the Info button; that will bring up a window displaying

- Cue list name;
- Cue list creation date and time;
- Cue list last modification date and time.

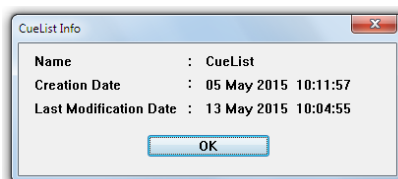

Tip To enter timecode values, use the control surface keyboard's numeric keypad. The keypad features a double-zero key (00) to speed up the process. You do not have to enter any punctuation marks – i.e., no colons or commas between hour, minute, second, and frame values – since they will be added automatically.

Click-and-Scroll Method This is an alternate method for fast timecode entries. It is initiated by the clicking-and-holding the left touch pad button followed by a touch pad move in vertical direction.

4.4.5.2 Theatre Cue List

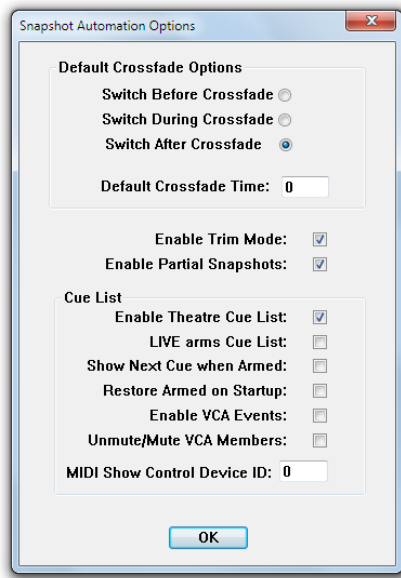

In order to activate the ‘theatre cue list’ functionality, enter the Snapshot/ Snapshot Automation Options menu and tick the Enable Theatre Cue List item (the further menu options are described in [chapter 4.4.5.2.15](#)). The cue list window looks similar to the screenshot below. A detailed theatre workflow tutorial is given in [chapter 4.4.5.3](#).

In addition, the D950system.ini file must be modified by the system administrator with the following entry: [options] -TheatreMode=Yes.

The *Virtual Vista application* not only lends itself for offline system setup, but also for preparing a theatre cue list for a new show, while e.g. the console is still used for the show currently played. For details of Virtual Vista, please refer to [chapter 2.11](#).

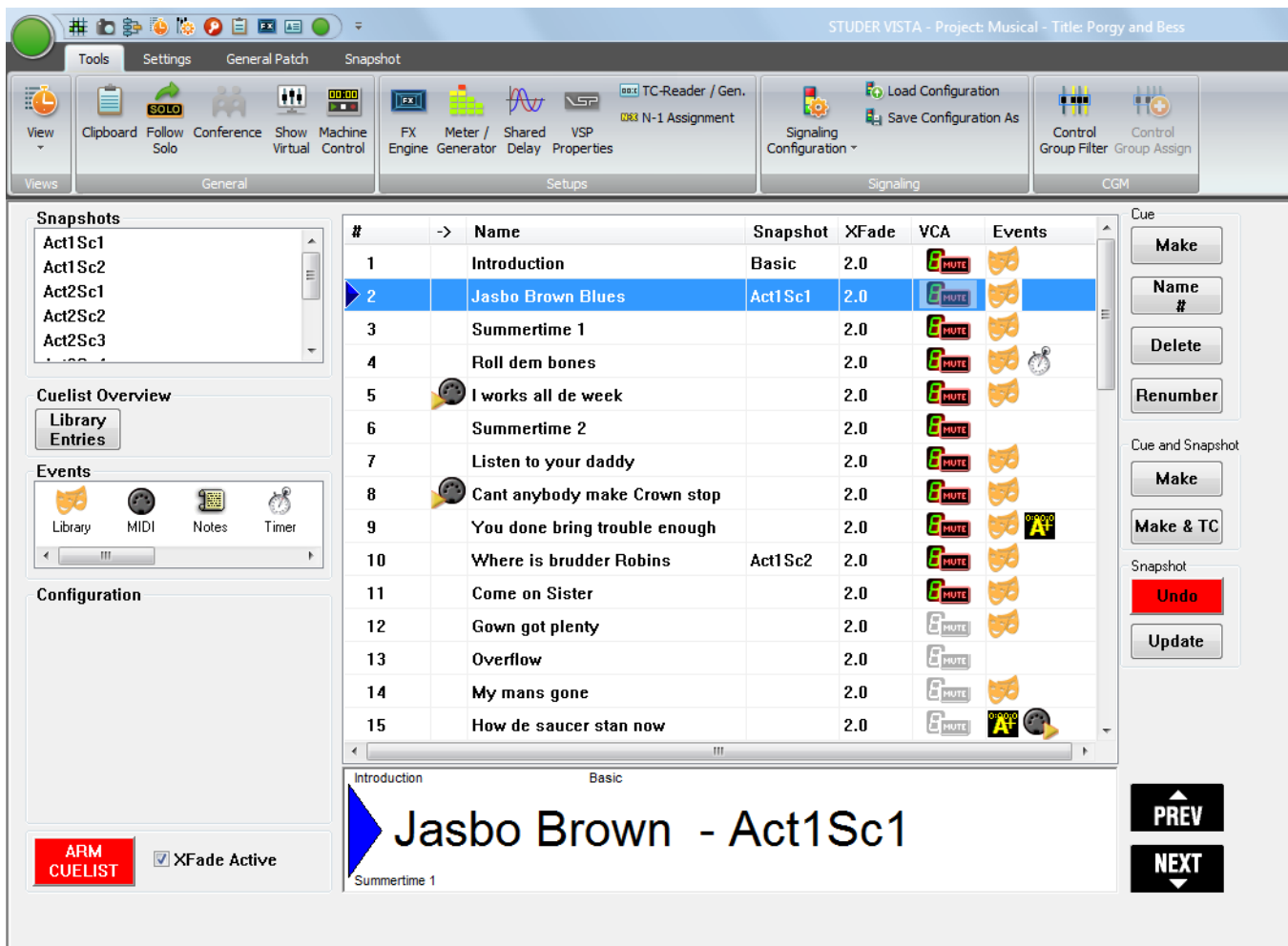

The theatre cue list contains the Snapshots, Events and Configuration areas at its left. The Snapshots area shows the currently available console snapshots; they can be dragged-and-dropped into the desired cue row of the cue list’s # column. The Events area allows dragging-and-dropping the desired

events into the cue list's **Events** column. If one of the events is selected, the **Configuration** area shows the settings and options useful for the current event.

A click on the **Library Entries** button opens the cue actor overview window that gives a comprehensive overview of all library events.

At the bottom of the theatre cue list window, the name of the current cue (and snapshot, if appropriate) is indicated in large characters so that it may be clearly read even from a certain distance. The last and the next cue's names are displayed as well at the upper or lower border of this indication field in small characters. Any desired cue from the list can be recalled either by double-clicking on its name or by using the **PREV** or **NEXT** buttons.

| | |
|------------------------------|--|
| Cue Name and Number | The buttons at the right-hand edge of the theatre cue list: The Name # button is used for entering/editing a name for the currently selected cue, and for manually editing its number. |
| Make a New Cue | Make inserts a new cue below the one currently selected. Its number is generated automatically. If the selected cue is, e.g., #14, the new cue's number will be #14.5, and its name will be Cue 14.5; a next one will be #14.75, etc. |
| Renumber Cues | After having edited the theatre cue list by making new or deleting cues, the Renumber button allows renumbering a selection of cues. In order to renumber the complete list, simply select all cues before. |
| Make Cue and Snapshot | The Cue and Snapshot - Make button allows generating a cue, together with a snapshot of the whole console, in one go; the new cue is named according to the rule given above, and its name will be 'SNAPSHOT #x'. With Snapshot Update , the snapshot of the selected cue is updated with the current console settings; this can be undone using Snapshot Undo . |

4.4.5.2.1 Cross-Fading Between Cues

Each cue displays a value for the cross-fade time when activating this cue. To modify the cross-fade time, point to the digits, hold the left touch pad button, and scroll up or down. Alternatively, enter the number using the numerical keypad.

When clicking on the cross-fade time once, options for the behavior of switches during cross-fades become visible in the left part of the window (Options Area). For each cue it can be defined whether the switches should change their state before, in the middle, or after the cross-fade – while the other parameters are changing seamlessly.

Within a cue, a partial snapshot may be recalled, influencing only certain parts of the console. If a larger cross-fade time is applied to this and the next cue is recalled before the last cross-fade has been finished, there will be two cross-fades happening at the same time, possibly with different cross-fade times. Only if the two cues change the same parameters, the first cross-fade will stop and the second one is applied from this point onwards.

Example

| | |
|-------------------|---|
| <i>Given:</i> | All Faders are set to 0 dB. Cue #1 contains a partial snapshot, setting faders 1...10 to -20 dB, cross-fade time 10 s. Cue #2 contains a partial snapshot, setting faders 11...20 to -40 dB, cross-fade time 1 s. |
| <i>Procedure:</i> | Recall Cue #1, e.g. by double-clicking on its name. Faders 1...10 will start moving down slowly. Five seconds later, Cue #2 is recalled. Faders 11...20 will start moving down. |

After six seconds, faders 11...20 have finished their cross-fade and are set to -40 dB.

After ten seconds faders 1...10 also have finished their cross-fade and are set to -20 dB.

4.4.5.2.2 Organizing Events

It is possible to move events from one cue to a different one by using drag-and-drop. Also, snapshots may be moved between cues using drag-and-drop. In this way, snapshots can be replaced or exchanged within cues.

4.4.5.2.3 Updating Snapshots

The snapshot names displayed in the cue list are only referring to the corresponding snapshot contained in the snapshot list. It is therefore possible to use the same snapshot in multiple cues, possibly using different cross-fade times. When updating a snapshot, the cues containing it will automatically use the updated snapshot.

Note Snapshots can be updated from within the cue list window; right-click on the snapshot within the snapshot list in the top left corner in order to get different options, such as **Make, Update, Name**, etc.

Alternatively a button has been introduced which allows updating a snapshot directly out of the cue list window (not shown in illustrations above.)

MIDI MIDI note and program changes can be used both as sources for firing a cue, or as events to be sent out of the console upon recalling a cue. In order to attach a MIDI command as a cue trigger, drag-and-drop the MIDI icon to the left side of the cue name. If a MIDI command should be sent out upon cue recall, drag-and-drop the MIDI icon to the right side of the cue. Multiple events may be added to the right side of a cue.

4.4.5.2.4 BlackOut

It is possible to make the whole console surface go dark. This function is useful in case complete darkness is required, e.g. in a theatre environment. This function also includes the optional console illumination. It can only be activated if the cue list is armed. The console lights come back on again either by the next BlackOut event (Parameter: OFF) or by pressing F3 in the control bay.

4.4.5.2.5 Arm CueList

To avoid undesired influence by external devices, the cue list inputs may be armed or disarmed. If not armed, the BlackOut function, the MIDI IN events, and the NEXT and PREVIOUS keys in the control bay are disabled.

It is possible to set the default value of the **ARM CUELIST** button by using the Snapshot/Snapshot Automation Options menu.

4.4.5.2.6 XFade Active

It may be useful to temporarily disable cue cross-fades (e.g., during rehearsals). This can be done by un-checking this item.

4.4.5.2.7 Preview



The snapshot/cue preview mode can be activated either by a hardware key or by clicking on the button located in the top right corner of the cue list window. When in preview mode, the cue or snapshot currently selected (single click) is compared to the current audio settings. If there is a difference, Vistonics shows both values at the same time, using a pink graphical indication. When pressing the dedicated snapshot keys above the touch pad, the preview mode is automatically activated until the same key is pressed again.

4.4.5.2.8 MIDI Show Control Device

It is possible to control the cue list by using 'MIDI Show Control' commands. the Vista console acts as a slave in this case. The following 'MIDI Show Control' commands are supported: Go, Stop, Resume, Load, Reset, Standby+, Standby-, Sequence+, Sequence-.

Vista is designated as a Music Command Format (0x11). The MIDI device ID is set in the Snapshot/Snapshot Automation Options menu.

Examples

Next Cue: F0 7F [Device ID] 02 11 01 F7 (*Go command*)
Previous Cue: F0 7F [Device ID] 02 11 12 F7 (*Standby Command*), then
 F0 7F [Device ID] 02 11 01 F7 (*Go Command*)
Recall Cue 3.5: F0 7F [Device ID] 02 11 01 33 2E 35 F7 (*Go Command with Q specified*)

4.4.5.2.9 MIDI Port Deactivation

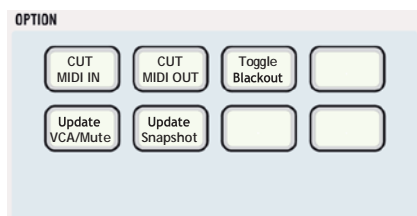

For enabling or disabling (cutting) the MIDI control input and output ports, two of the **OPTION** desk keys can be used

The MIDI In and Out ports can be disabled, (together with the blackout function as well as the hardware **NEXT** and **PREVIOUS** keys on the console surface) using the **ARM CUELIST** button in the theatre cue list. Different options can be set in the Snapshot/Snapshot Automation Options menu.

4.4.5.2.10 Event Types

Library Events

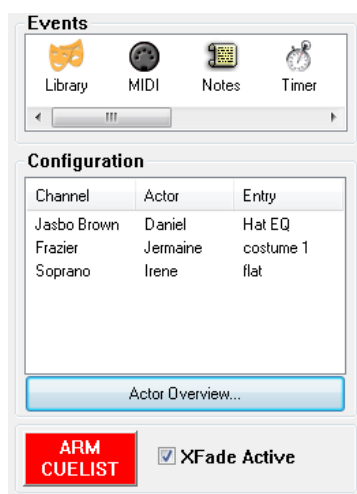

Cue-based theatre productions need a large number of parameter changes per channel, usually for a number of subsequent cues.

Example: In scene 3, the character Jasbo Brown played by Daniel wears a wide-brimmed hat, changing the sound of his lavalier microphone due to reflections.

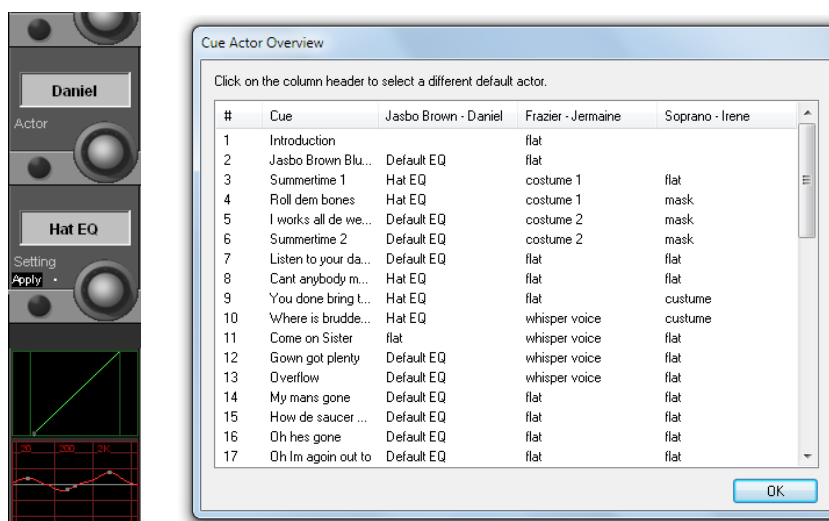

The solution is to modify the EQ of his channel in order to make up for the different microphone response. This is valid for cues 3, 4, 8...10, etc., ('Hat EQ'). For cues 5...7, the original EQ settings have to be applied, while cue 11 demands for a flat EQ. This can easily be achieved with Library Events. They may be adjusted while running the show, without the need to update the cue settings that are ahead of the current cue.

A detailed theatre workflow tutorial is given in [chapter 4.4.5.3](#).

MIDI/MMC Events

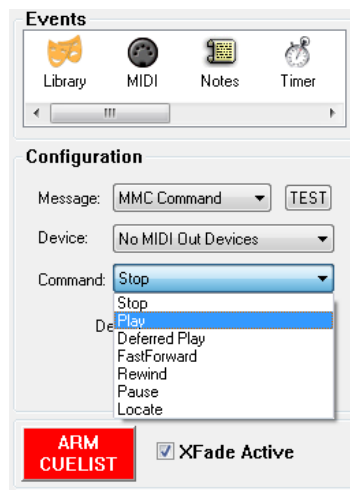

The MIDI/MMC (MIDI machine control) event type can either be used for automatically sending MIDI commands if the symbol has been entered into the **Events** column (such as Program, Note On, Controller, MMC and Sysex), or for triggering the associated cue on arrival of the command if the symbol has been entered into the → column (such as Program, Note On or Controller).

MMC commands are a subset of the MIDI Sysex ('system exclusive') command set that are used for triggering transport commands for external playback equipment, such as Stop, Play, Locate, etc.; 'Deferred Play' is a Play command that is executed after the playback transport has found the desired cue position.

A MIDI event is entered either by dragging it from the **Events** area and dropping it into the **Events** column of the selected cue, or by a right-click into the **Events** column of the selected cue and selecting the desired event from the dropdown list. It can be configured in the **Configuration** area, or deleted if highlighted by a click and either pressing **Del** on the keyboard or clicking on the **Cue Delete** button.

If MIDI input control signals are used, a MIDI event symbol is inserted into the → column of the cue list, either by dragging-and-dropping it from the **Configuration** area or just by double-clicking into the desired cue list cell. For deleting it, either highlight it with a click and press **Del** on the keyboard or click on the **Cue Delete** button. It can also be deleted from the cue list with a double click.

In order to avoid undesired influence by external devices, the **ARM CUELIST** button is used to arm/disarm the cue list inputs. If not armed, the blackout function, MIDI In events, as well as the hardware **NEXT** and **PREVIOUS** keys on the console surface are disabled. Different options for this button can be set in the **Snapshot/Snapshot Automation Options** menu.

Timed Events

For a timed event, the time until the next cue is recalled as well as the number of the next recalled cue can be set. When clicking into the corresponding entry field, the recall time can also be adjusted by moving the mouse or the touch pad up/down (range: 0...60 seconds). A progress bar is shown in the large cue area while the timer is running.

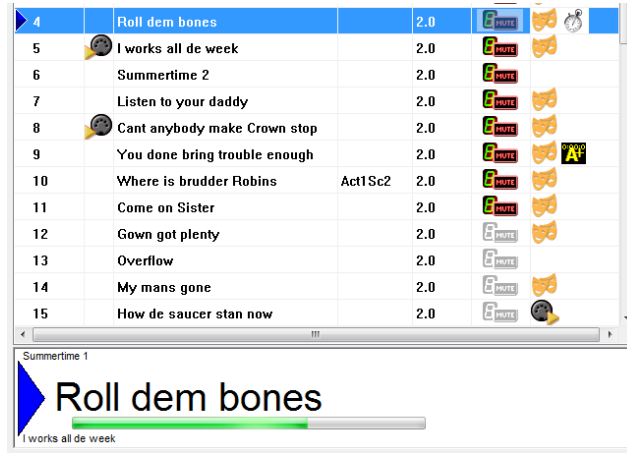

Dynamic Automation Events

With dynamic automation events, automatic parameter changes can be inserted into a cue, such as cross-fades, panorama or AUX level changes. Programming such events is very convenient and easy. Dynamic automation events are only used when working with the theatre cue list, therefore the console has to be started in static rather than in dynamic mode. After a click on the Dyn Auto icon in the cue list it is highlighted (blue background), and the Configuration area shows the controls used for the dynamic automation, see below.

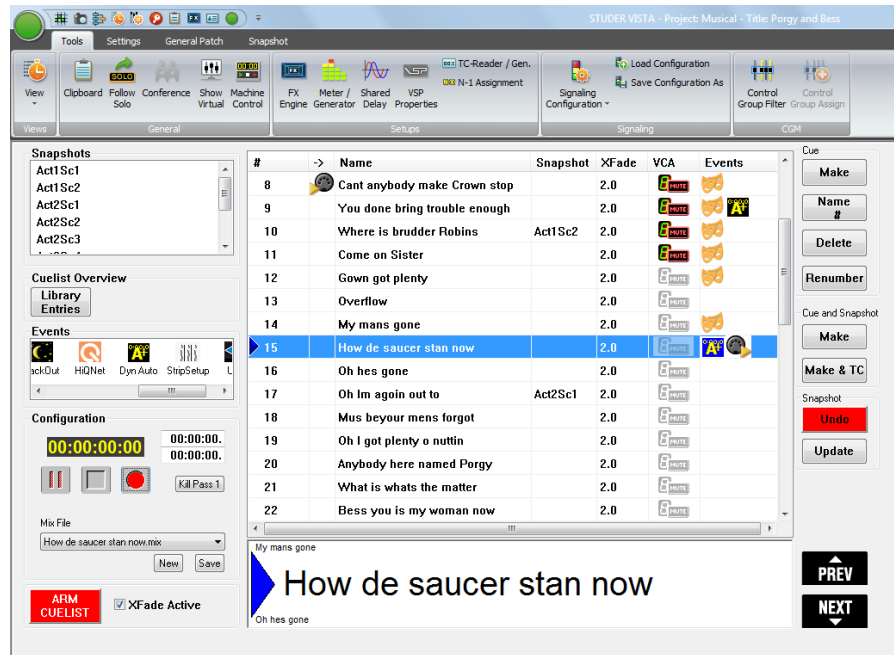

For recording, e.g., a fade-in, just click on the [record] button. The automation system switches to record-pause mode, the record button's color changes to red [red record], and the [play] button is replaced by [pause]. Parameter recording is then started either by touching a control (fader or rotary knob),

by pressing a key (e.g. **MUTE**), or by a click on the pause button. Once the recording is complete, click on  stop.

The easiest way to record different controls at once (such as for a cross-fade), this is best done on the console. However, since the automation system allows several record passes with different controls, one after the other, a cross-fade can also be recorded with Virtual Vista on the online editor, or even on the offline editor.

All mix passes are saved, and if the operator is unhappy with the last one (or several of them), he just uses the Kill Pass x button in order to delete as many of the mix passes as desired. *Please note that no 'undo' function is available for the Kill Pass x button.*

The cue mix files are saved in the CueMixFiles subfolder of the D950SYSTEM folder (main D950 projects folder). They follow the same folder structure as the ones of the standard automation mix files and can, of course, be exchanged with them. In other words, any existing automation mix file may be copied into the CueMixFiles subfolder of the current production, and vice versa, except that the cue mix files are not saved pass-by-pass. For more information, please refer to [chapter 5.5](#).

VCA/Mute Events

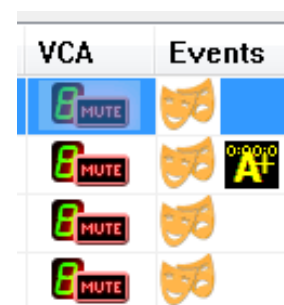
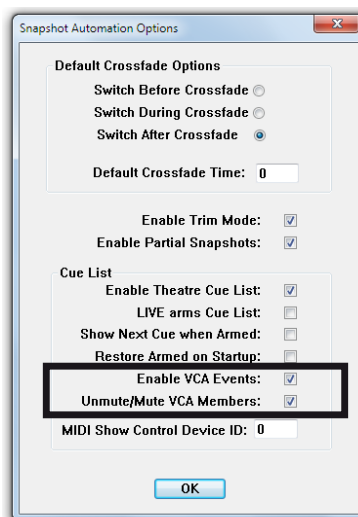

VCA/mute events must be activated in the Option – Snapshot Automation window by ticking **Enable VCA Events**, as shown above.

Particularly in large, cue-based musicals, assigning channels to VCA masters provides the basis for the mixing console cue list. It is very easy just to use a small number of VCA masters during the show, reassigning slave channels from cue to cue, instead of working on a very large number of input channels directly.

One of the main tasks when setting up a cue list for a production is assigning the appropriate channels to VCA masters on every single cue. With VCA/mute events this is achieved very easily.

After a double-click on the desired VCA/mute event in the cue list, the VCA details window opens.

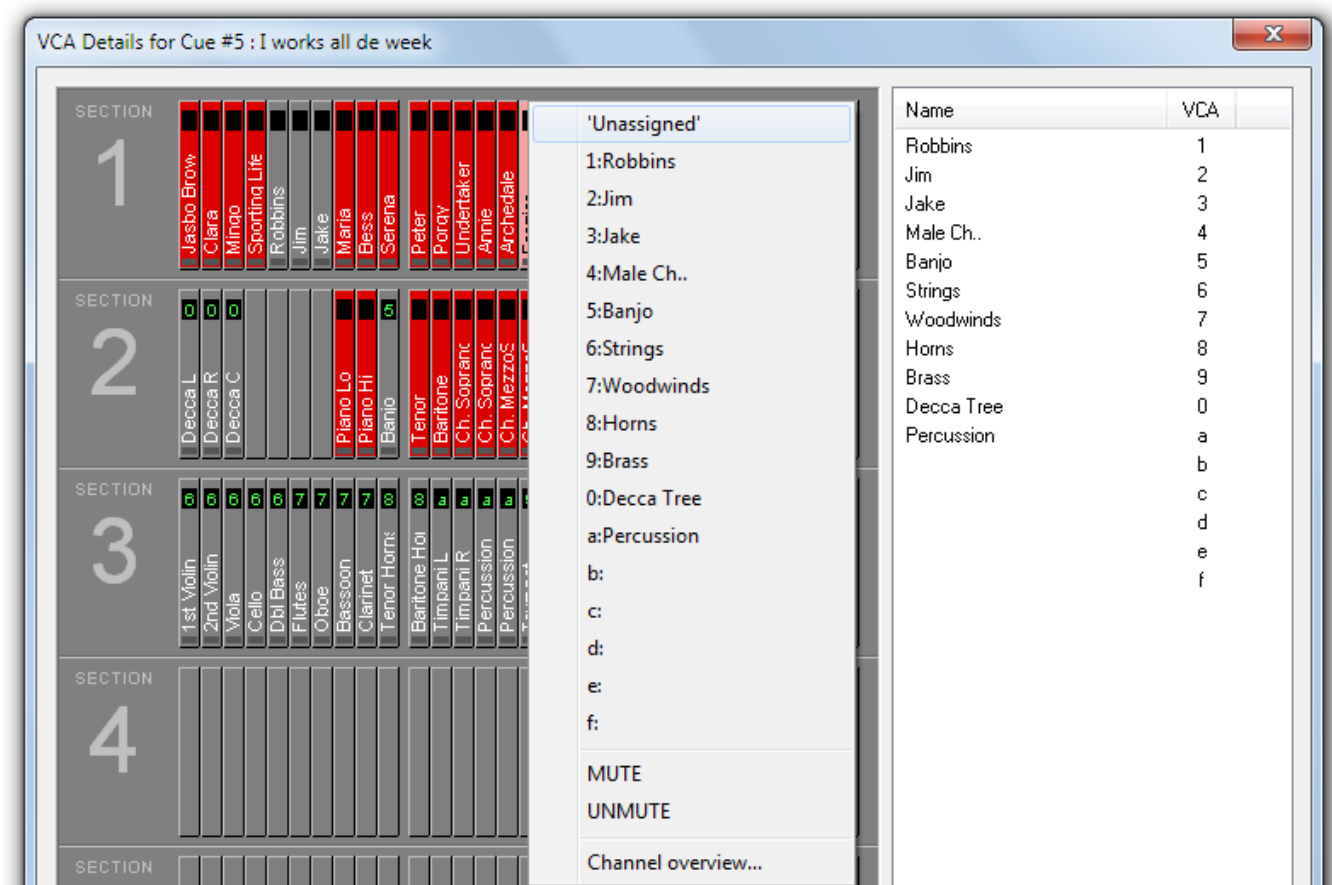

All channels currently muted are indicated in red. The ones being part of a VCA group have the group number in their upper part. When right-clicking on one of the channels, a list with all group assignment possibilities pops up; a channel can also be muted or un-muted without an assignment to a VCA group.

A detailed theatre workflow tutorial is given in [chapter 4.4.5.3](#).

UAD Snapshot Events

From Vista SW version V5.2 onwards, Soundcraft's Real Time Rack Plug-in engine is supported.

To store and recall Real Time Rack effect parameters, an event type called "UAD" has been introduced. By dragging and dropping this event, Real Time Rack-data can be assigned to individual cues.

Every time when a UAD event is dragged to a cue, the Real Time Rack will transmit all data to the Vista desk where the data gets stored into the event as an UAD snapshot.

If a cue with an active UAD event gets fired, all the stored UAD snapshot data will be applied to the Real Time Rack. This includes plug-in type assignment in the 16 channels of the engine as well as all the parameters.

By clicking onto the assigned UAD event of a cue, the Configuration area will show the details.

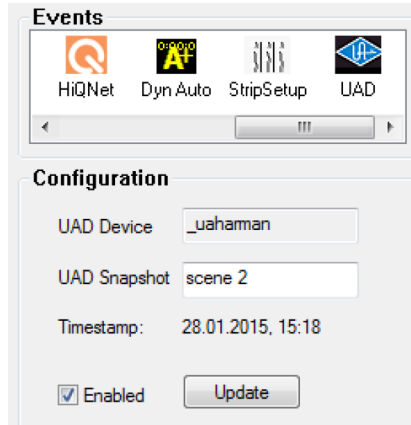

- Rename UAD snapshot The UAD snapshot can be renamed to a more realistic and cue depending name.
- Enable UAD snapshot The **Enabled** checkbox is checked by default after an UAD event is created. By unchecking it, the UAD snapshot will not get executed when the cue is fired.
- Update UAD snapshot Clicking the **Update** button will transfer all the current setting data from the Real Time Rack to the desk, and the UAD snapshot of the currently selected UAD event will be overwritten – the UAD snapshot gets updated.

Note : There is no relation of the UAD snapshots to any kind of console isolation states and filtering.

StripSetup Events Saved StripSetups created in the StripSetup window can be assigned to cues as StripSetup events. By firing the cue, the selected StripSetup gets loaded onto the desk. This is a great feature in rehearsed shows like theatre shows or live broadcast shows, where several different StripSetups are required, to automatically bring the desired channelstrips up onto the desk surface.

Clicking onto the StripSetup cue event icon shows a combo box in the Configuration area of the cue list page. This is where you select the desired strip setup file you want loaded for that cue.

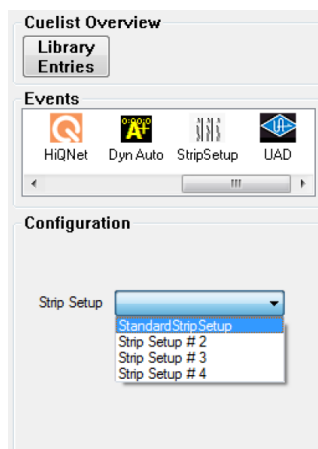

TimeCode Events The TimeCode trigger event allows cues to be fired by a timecode value. When an external timecode is fed to the Vista console, TimeCode trigger events can directly be created with the button **Make & TC - Cue and Snapshot**. The current timecode is then stored as the trigger time for the newly created cue.

Later, when the Cue List is armed, and timecode is running through the same value, this cue will be fired.

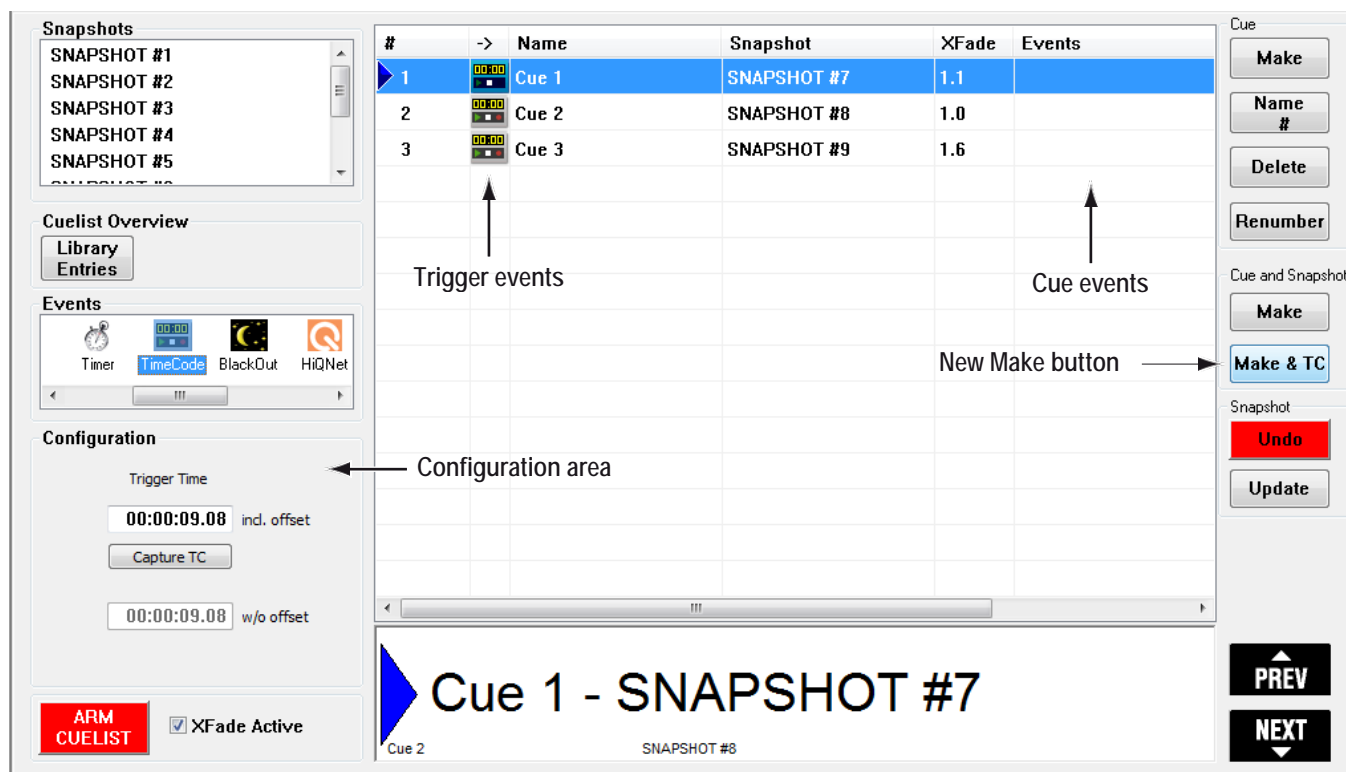

In the Configuration area of the Cue List, the stored timecode value is visible and can also be edited. Editing is very convenient, as numbers can be entered directly, but also clicking on a digit and dragging the trackball up or down allows very quick changes to a timecode value. Also right-clicking onto the event icon allows to shift the timecode trigger value.

In the Ribbon tab Tools, category Setups, opening the “TC Reader/Gen.” dialog, all parameters regarding TC reader can be entered.

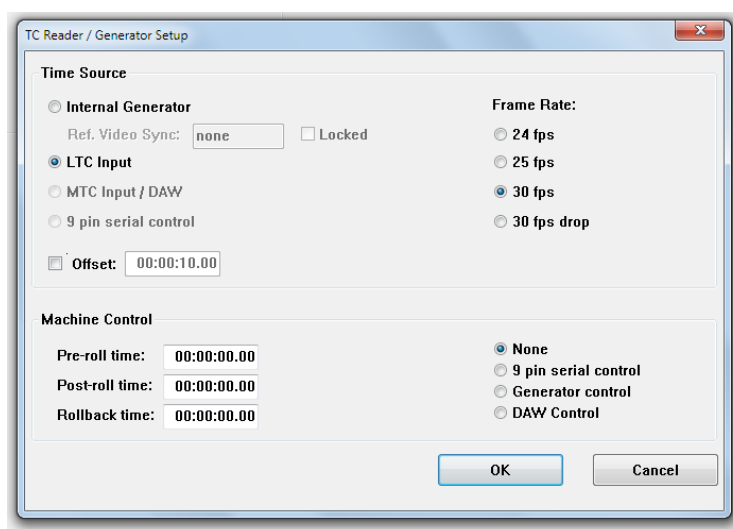

There is also the possibility to enter and activate a global TC “Offset” – this is useful in the case all configured TimeCode trigger events in the whole Cue List need to be shifted up or down against the external TC source.

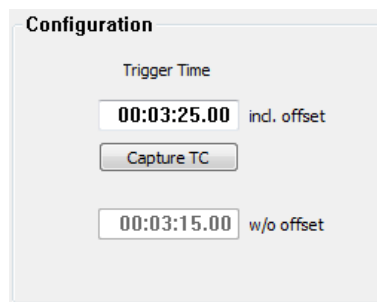

In the Cue List, the upper TC window in the configuration area displays the TC at which the cue will be fired “Trigger Time incl. offset”. The lower window “w/o offset” shows the original TC – the TC value as it was without the introduced offset.

TimeCode events can be deleted from cues as other events – by right-clicking on to the event icon and clicking onto “Delete event”.

4.4.5.2.11 VCA / Channel Mute Mode

A snapshot includes all audio parameters of the console by definition. This means that the sound designer would have to specify for each cue what audio parameters should be masked from snapshot recall, so that only certain parameters change. In most cases however, making changes of VCA assignments, VCA labels, and channel mute status per cue is preferred, rather than working with snapshots in the ‘normal’ sense. Aside from this, the desk has to work in a manual way whereby the operator is not concerned with snapshot recall but only with changes of certain parameters within certain cues. The theatre cue list offers a philosophy that does not only deal with snapshots and attached recall masks per cue, but offers that the snapshots of the VCA/mute and other parameter changes are handled per cue by a library system that stores the parameters.

Please note that the VCA assignment and channel mute parameters are neither saved nor overwritten by snapshots.

This functionality is enabled in the `D950system.ini` file by the system administrator (`[options] - TheatreMode=Yes`).

4.4.5.2.12 Isolate Labels and VCA Assignment

In order to allow label changes being copied into several snapshots (by recalling and updating snapshots) they need to be able being isolated on an input port-by-input port basis. This is done right-clicking the user label in the general patch page. There, **Isolate User Label** can be checked. If isolation is active, in the source list, the user label is marked with a yellow spot.

Isolated User Label

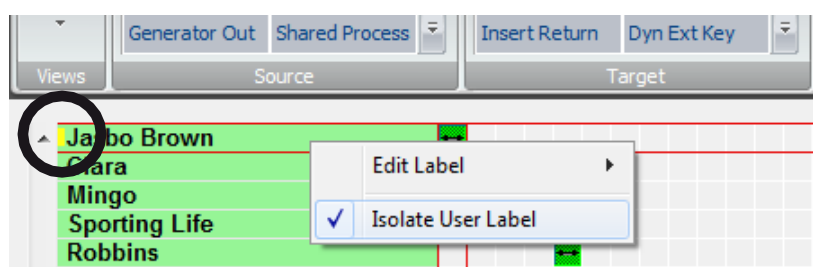

The VCA assigns need to be able to being isolated as well. The VCA assign isolation can also be done on the input channel side, individually channel-per-channel. This is done in the channel patch page.

Isolated VCA Assignment

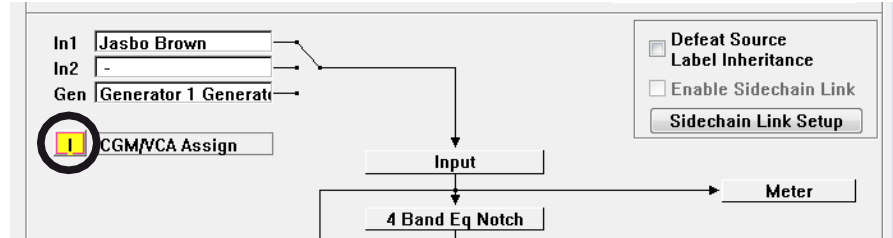

Isolated VCA User Label

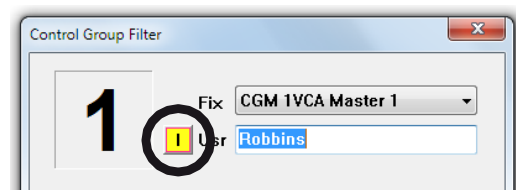

4.4.5.2.13 Mute Groups

In theatre mode, the mute groups are fully independent from snapshots and VCA/mute events. Mute group mutes will neither be saved in the snapshots in this case, nor will they be overwritten by a snapshot recall.

4.4.5.2.14 Hard Mute

'Hard mute' is an additional mute status. It can be used in the same way as a mute group, but doesn't need a mute group setup and has, in particular, top priority over any other programmed mutes. This means that a hard mute is fully independent of what is recalled via a snapshot, a VCA/mute event or a mute group. It can be applied to every desired channel at any time, making sure that no audio is passing through this/these channel(s). Its main purpose is solving problems with a channel, if, e.g., a wireless microphone is defective.

In order to set up a hard mute, first the corresponding option needs to be activated. This is done in the Settings/Vista Settings window. Select the Misc tab and tick the Live mode activates Hard Mute entry.

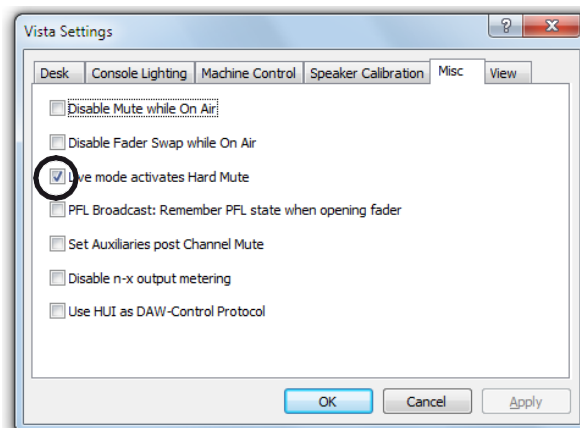



A click on the **LIVE** button (or pressing the small **LIVE** key in the desk's CONTROL ROOM monitor section) followed by a channel **MUTE** button activates a hard mute of this channel, regardless whether this channel is currently muted or not. If a channel is hard-muted, a **HARD MUTE** indicator appears in the Vistonics label area, and the **MUTE** button is illuminated.

If a hard mute is applied to a channel that already has a 'soft mute' caused either by the system (via a snapshot or a VCA/mute event) or manually with the **MUTE** button, this is indicated by illuminating the **MUTE** button together with the small **MUTE** LED, as shown below.

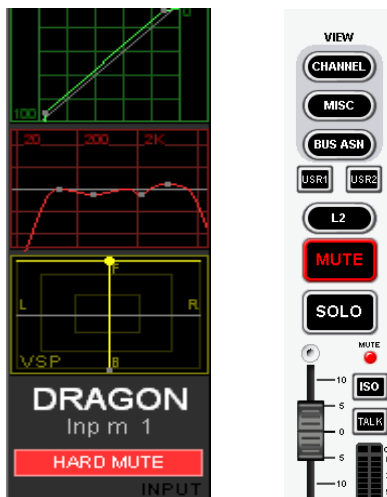

4.4.5.2.15 Cue List Options Menu

In the ‘Option - Snapshot Automation Options’ menu the following options are available:

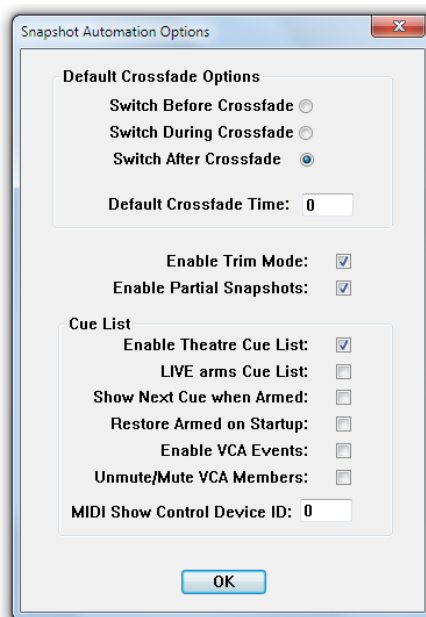

Default Crossfade Options

Switch Options

The system allows cross-fading between two cues. The default cross-fade values may be defined here. These will be used whenever a cue is created.

Describes the behavior of switches (e.g. **MUTE**, **EQ** on/off etc.) during a cross-fade. They apply if a switch changes its state in the next cue. They may change their state before, during, or after the cross-fade.

Default Crossfade Time

Set default value of cross-fades when new cues are created (enter in seconds).

Enable Trim Mode

When pressing-and-holding the **ISO** key on the channel strip followed by touching individual controls (e.g. faders, rotaries), their state can be isolated from snapshot recalls. If this option is on, the particular parameter may be touched a second time. This will set it into Trim mode. In this mode all changes to that parameter since the last snapshot recall will be applied relative (!) to all upcoming snapshot recalls – thus, not modifying them on disk.

Enable Partial Snapshots

Activates the ‘Partial snapshot’ feature. It will be possible to include only ganged channels when making a snapshot. Options are available within the snapshot window of the GC screen.

Cue List

Enable Theatre Cue List ONAIR arms Cue List

Enables extensive functionality of cue lists.

When pressing **LIVE** in the **EXT PFL SPEAKER** area of the Vista control bay, the state of the cue list will change accordingly.

Show Next Cue when Armed

Defines whether the currently active or the next cue should be highlighted when the cue list is armed. This also allows reading the attached notes ahead during the live event.

Restore Armed on Startup

The system will switch the console into the ‘armed’ state whenever the software is started. This allows e.g. constant reception of external MIDI commands for firing off cues.

Enable VCA Events

See [chapter 4.4.5.2.10](#).

Unmute/Mute VCA Members

See [chapter 4.4.5.2.11](#).

MIDI Show Control Device ID

See [chapter 4.4.5.2.8](#).

4.4.5.3 Theatre Workflow Tutorial

| | | |
|------------------|--------------------------------|---|
| | | In general, a cue-based production usually has a workflow similar to the following scenario: |
| 1. | Console Setup | The channels are labeled, patch connections are made, etc. |
| 2. | Building Cues | With the help of the script, the cues are created and named. VCAs are labeled and channels are assigned to VCAs. Mutes are made (per cue). |
| 3. | Rehearsal Phase | This is the first time that the cast is involved. No orchestra yet, just a piano. Mic gains and EQs are set, but only in a hurry, since rehearsals go fast (through all cues). With more rehearsals, the mic gain and EQ settings get refined. Cues need to be added. |
| 4. | Dress Rehearsal Phase | This is the first time that the orchestra/band is involved. These channels can now be setup (gain, EQ, monitor mix). Now with dresses, props and orchestra, vocals sound different; mic gains and EQs need to be refined. |
| 5. | Preview Rehearsal Phase | This is the first time that an audience is involved. Things sound different again since the audience modifies the acoustics of the venue. Fader levels, gains and EQs need to be adapted. |
| 6. | Shows | During the show, the console operator reads the script, goes from cue to cue and rides VCA master levels. Usually there is no time available for changing parameters apart from the VCA levels. Basically, the channel settings don't change anymore, but it may happen anyway (almost every show) that an actor or a musician of the orchestra needs to be replaced due to sickness or other reasons. This means that channel settings such as mic gain, EQ and dynamics need to be adapted to the current understudy actor; this is, however, only required for the corresponding input channels. |
| Glossary: | Character / Role | The name or term of the character or role in the script, such as Romeo, Julia, etc. It is very important to understand that one input channel of the console should always be fed with the mic signal of one certain character/role throughout the whole play. |
| | Actor | Name of the person who is playing a specific character/role. |
| | Understudy | Actor who replaces the main actor in case of sickness, different shifts, etc. |
| | Cast | The ensemble/company, i.e. all (or several) actors or all actors of a play. |

Conventions for the Workflow Suggested Below:

- An input channel of the console is equal to a character of the play.
E.g. Inp m1 = Romeo; Inp m2 = Julia, etc.
- When the role of Romeo is played by an actor called John Smith, an actor for Romeo's role (Inp m1) needs to be created whose name is John Smith.
- Later on, an understudy actor can be created as a copy of John Smith but with the actual understudy's name.

4.4.5.3.1 Console Setup

Tip Always work with active device labels (Settings/Device Labels: Use Device Labels, and Overwrite Chan. User Label with Device Label)



In this phase, all the necessary console setup work is made. No actors or musicians need to be on stage. Therefore this setup phase can also be done with Virtual Vista without having the physical console available.

- Create an appropriate VMC configuration.
- Load this configuration and create appropriate project and title names for the particular production.
- Do the labeling of interfaces (device labels).
- Create patch points – from interfaces to input channels, from output channels to output interfaces, as well as every other patch connection that is needed (e.g. shared processes).
- Add the user labels to the input interfaces, i.e., the labels of the characters of the play.

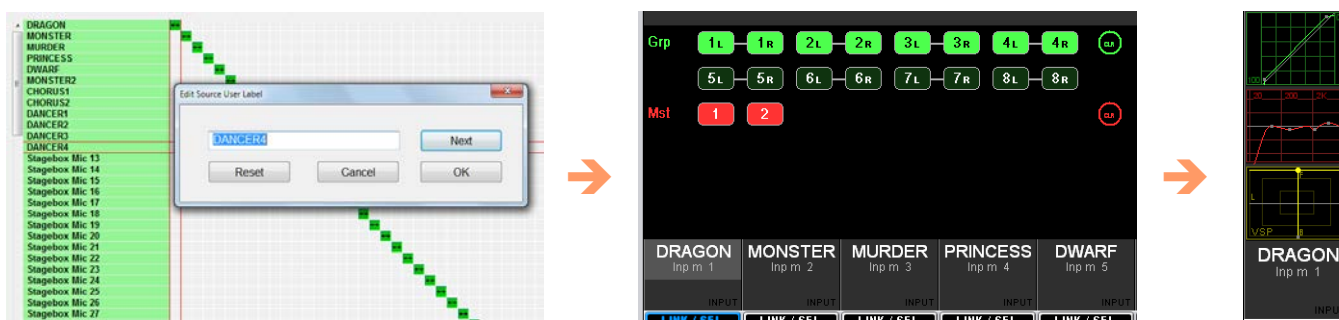

- Create a strip setup.
- Do the bus assignment as required for the particular production.
- Save this in a 'basic settings' snapshot or preset.

4.4.5.3.2 Building Cues

Cues can be built on the Virtual Vista. When the rehearsals begin at a later stage, the title needs to be transferred to the ‘real’ console. Depending on the time available, cues may, of course, be built on the ‘real’ console directly. In both cases the goal is having audio as soon as it is needed for the first rehearsals.

Creating Actors

Since the library events are sorted in the channel settings library by actor names, consider entering their real names, if they are already available at this stage. Having all the names already entered in the library ready to use and to save settings with it would be a good preparatory step. It may also be done later, however.

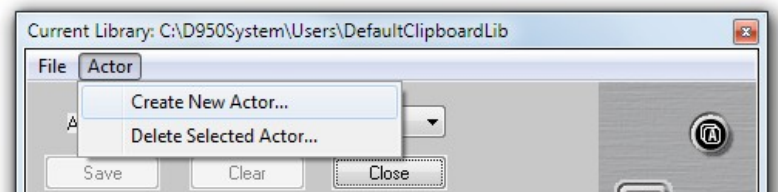

Creating Cues

This is the next step. It is usually done according to the script. The best way to do this is creating and naming all cues used for the play.

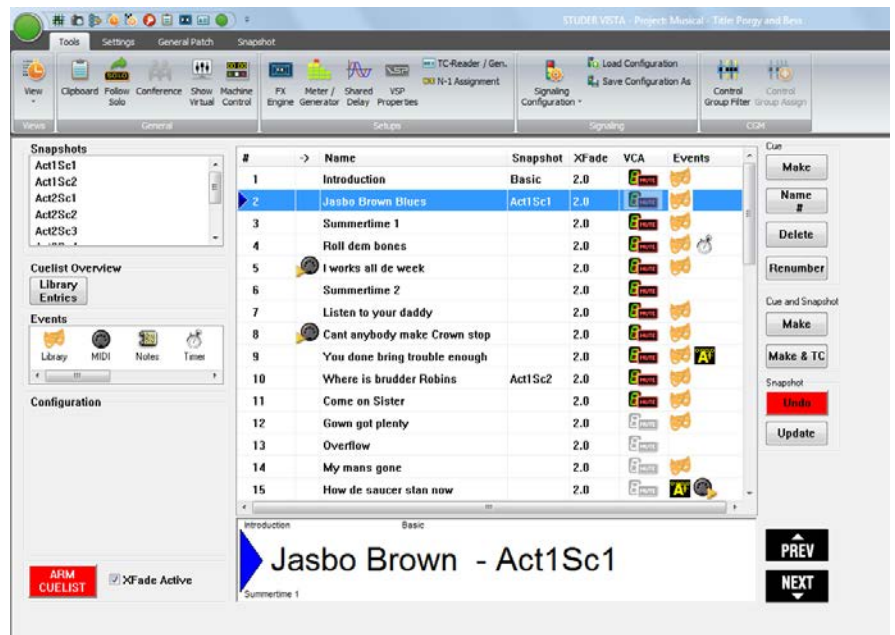

In the process, the Cue **Make** and Cue **Renumber** functionalities can be used in order to build and update the cue list until it is complete. This phase may last throughout several rehearsal stages.

Tip

In order to be able later to make efficient use of library events, it is recommended that the first cue of a show has a snapshot attached, making sure that the console is in a 100% defined state at the beginning of the show. This would be the ‘basic settings’ snapshot created during console setup. Since the library and the VCA/mute events are completely separate from snapshots, the console’s basic settings remain static for all channels for which no library events are used throughout the whole show. Adjusting any static

parameters of the console and overwriting the ‘basic settings’ snapshot is an easy way of updating the static settings, without affecting or overwriting the changes that are caused through the VCA/mute and library events on a cue-by-cue basis.

VCA Master and Mute Setup

Along with the cues, it is very likely that input channels are grouped and assigned to VCA master faders. The setup is done in a very efficient way using VCA/mute events . The whole setup process is done in one single window. Normally, the channels that are not used in a cue need to be muted, in order to avoid that an actor who still wears his wireless microphone backstage while he is e.g. changing his costume can be heard over the PA system. Therefore, all channels not assigned to a VCA master are muted automatically if the Unmute/Mute VCA Members option is ticked in the Snapshot/Snapshot Automation Options window, as shown below.

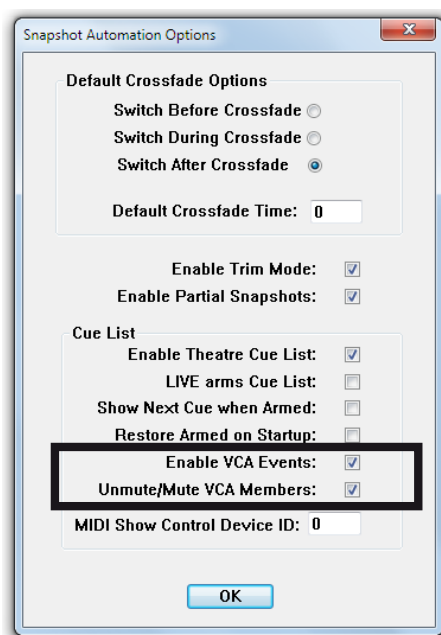

Either a double-click on the VCA/mute icon  or a single click on the VCA/mute icon followed by a click on the Edit VCA assignments... button (at the bottom of the Configuration area) opens the VCA Details window. It looks very similar to the strip setup window. Muted channels are shown in red, and the small digit at the upper end of every channel indicates to which VCA master this channel is currently assigned. By right-clicking on a name a history window is shown that lists the VCA names already used within the current production.

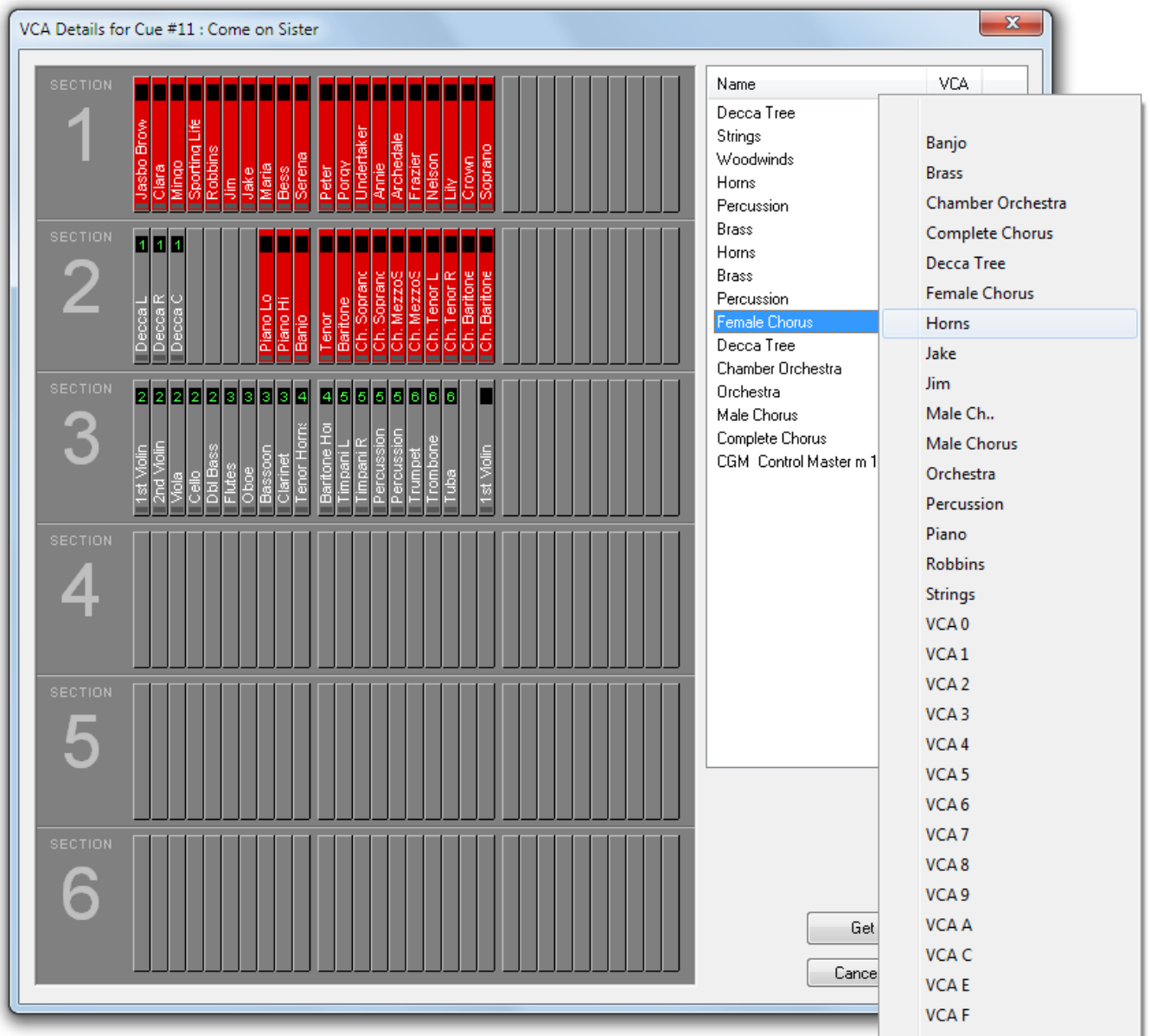

A right-click on the VCA/mute event icon of the current cue (i.e., the one that is currently highlighted) allows copying/pasting the VCA/mute settings from the current cue to a different one (that must be made the current cue, i.e. highlighted, before pasting).

Please note that the VCA/mute event settings of the current cue are copied and applied whenever a new cue is created. Then, the VCA/mute event icon is grayed-out , indicating that this cue's VCA/mute event settings are identical to the one in the cue immediately before.

Alternatively, the mute setup can also be done on the desk with the MUTE keys of the desired channels. The update in the current VCA/mute event is then done by opening the VCA Details window and using the Get Current Settings button at its bottom.

4.4.5.3.3 Rehearsal Phase

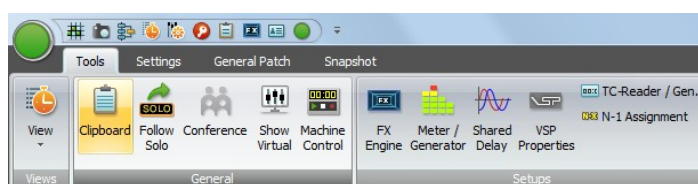

Once the basic settings are transferred to and saved within the console and the rehearsals are at a stage where the original cast is rehearsing, e.g. already in costumes and with the stage props, the cue list can be completed with library events where necessary.

Library Events Library events can be used to make the necessary parameter changes on a cue-by-cue basis, without the need of using snapshots to accomplish these changes. This makes the workflow easier, faster and more straightforward, allowing the operator focusing on the mix, rather than having to remember appropriate snapshot and snapshot filter states. Library event settings are visible in the clipboard library window that is opened with a click on Tools/Clipboard Library.







The collected settings are organized in such a way that a setting or a number of settings belong to a particular actor. Just select the desired actor from the Actor drop-down list to display his settings.

If the Actors have not been created already, they can also be created on the fly, together with the actual library event settings by copying them from a channel strip. To do this, proceed as outlined below.

- Go to the desired channel strip on the desk surface and copy the current setting of the desired processing block (or a combination of several processing blocks – PAN, EQ, DYN, INS/DEL, FILT, or ALL parameters of a channel at once) with the  or  keys.
- Paste it into the library under the desired actor. If the actor does not yet exist, it can be created while the copied parameters remain in the temporary clipboard.
- While being pasted into the library under an actor, the setting needs to be given a name. The naming of the setting is important, since later on only the names of the settings are shown on the Vistonics screen, and the operator needs to be able to select to appropriate setting just from reading the name.
- Once a setting is saved in the library, it still needs to be applied to the desired cue(s). For this purpose, the identification concept uses the names of the library settings.

Add a Library Event to a Cue

First, select the actors view on the Vistonics screen by pressing the  (Shift) and  (INPUT) keys. This is a global actor view across all Vistonics channels; a particular actor is also shown when opening the channel view using the  key.

With a right-click in the Events column of a cue and selecting the library event  symbol from the list that drops down, a library event is added to that cue. An alternative way to do this is by dragging-and-dropping the library event symbol from the Events area at the left of the cue list into the Events column of the desired cue.

By clicking on the icon once, the Configuration area opens in the lower left corner of the cuelist page. When right-clicking in this area, channels (i.e., characters), actors and library entries can be selected.

If the desired library setting has already been added to the actors' library, it can be dialed up with the Setting Vistonics rotary and applied to that specific channel in the current cue in the current cue with the Apply key. If there are no other library events further down the cue list, the applied library setting will remain active in the channel through to the end of the cue list. If other library events have already been applied to cues further down in the play, the new applied setting will only be applied from the current cue to the one right before the cue where the next library event is active.

Actor Overview... Window

An overview window of all library events throughout all cues and all channels is shown by a click on the Actor Overview... button. In this window the names of all entries are shown per cue. When right-clicking in this window, the entries can be changed, and further entries can be added.

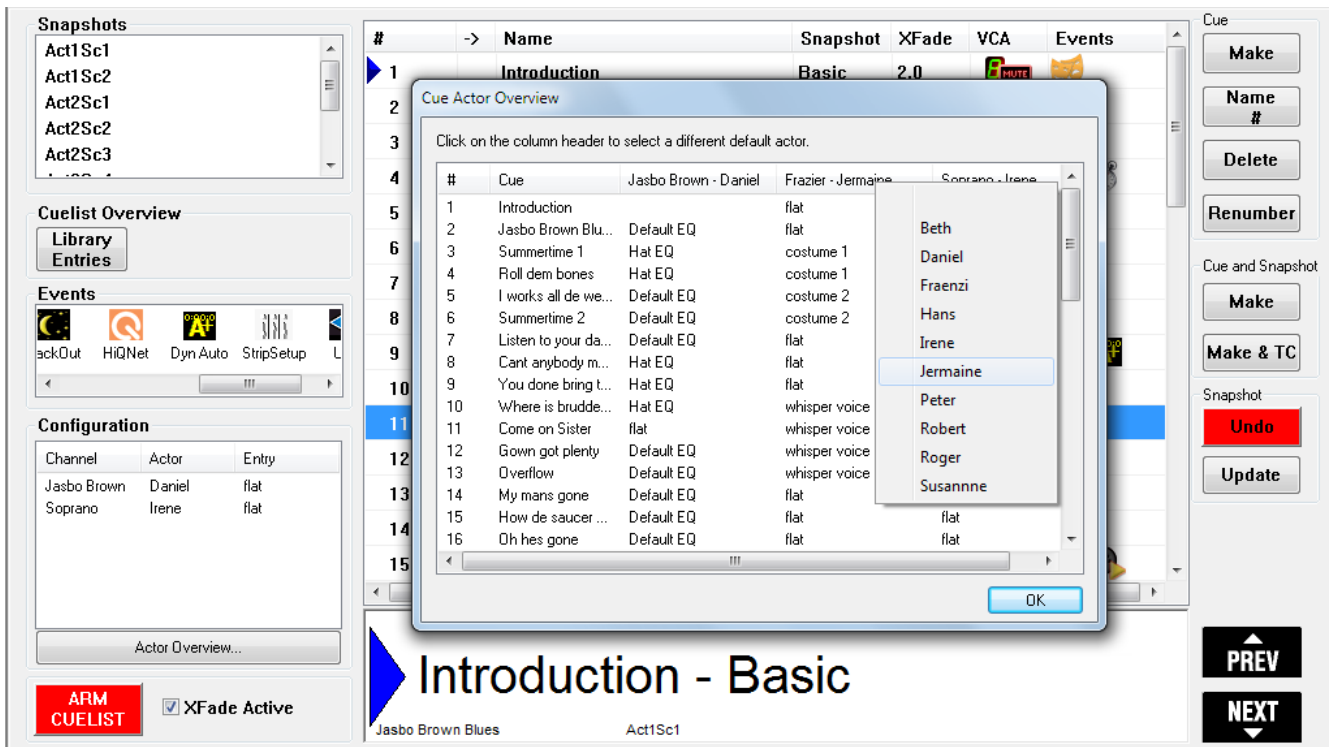

Other Events During the different phases of rehearsing, other events can be added to the cues as well:



MIDI

MIDI program changes, note-on, note-off and MMC (MIDI machine control) commands are available from the Configuration area once a MIDI event has been added.



Notes

Plain **notes**,



BlackOut

blackout events,



Timer

timed cue events,



Dyn Auto

dynamic automation events,



HiQNet

HiQNet events,



UAD

UAD events, and



StripSetup

StripSetup events, and



TimeCode

TimeCode events are available as well.

For detailed descriptions of each event type, please refer to chapter [4.4.5.2.10](#)

4.4.5.3.4 Shows

Tweaks During the performances, all console parameters can be tweaked. If these are static parameters (settings that remain constant throughout the whole show) and there is only one single ‘basic setting’ snapshot at the very beginning of the cue list, they remain with the same tweaked value until the end of the show.

If the changes should be kept for future shows, all these values can be updated simply by updating the ‘basic setting’ snapshot in the first cue.

Parameters that have been pasted into a channel from the channel setting library (i.e., library events) can be tweaked as well, and the changes are automatically transferred to all the cues where the same setting is used. The library event’s name in the clipboard library list and on the Vistonics channel view – such as **Hat EQ** – will then change to **Hat EQ***, with the ‘*’ (asterisk) signifying that it is different from its original setting. On the Vistonics channel view a **Revert** button is added. Pressing it will discard the changed library setting and bring it back to its original value.

If however such a changed parameter should be conserved and updated in the library while keeping its original name, the **Save** button must be pressed.

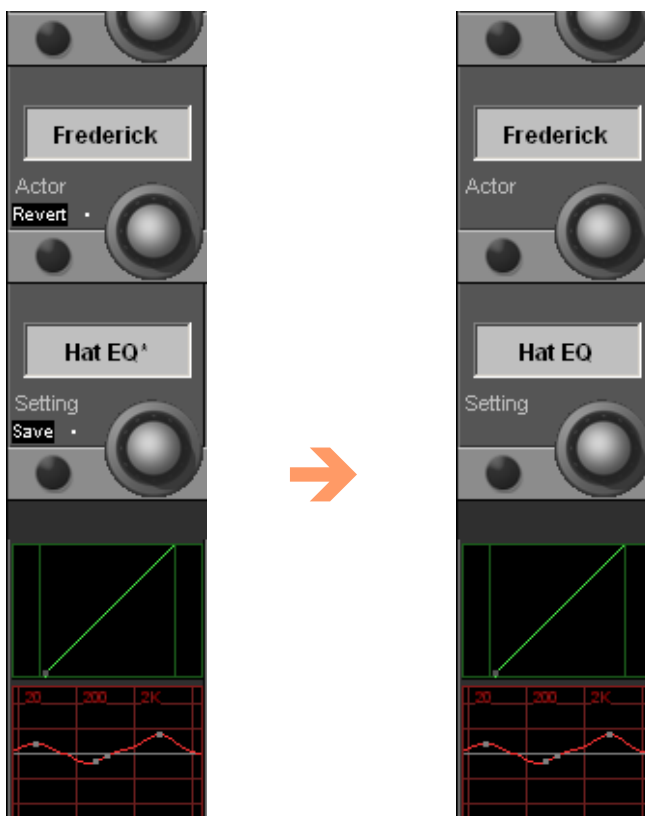

Understudy Settings With the repeated performance of a play, replacement actors (also called understudies) need to be considered. They will take over in case the main actor should get sick, or simply because shifts are introduced. New actors can be entered into the library just by making copies of existing actors, followed by modifying the individual settings of the understudies.

In the **Cue Actor Overview** window, the default actor can easily be replaced by a simple click on the ‘character - name’ bar and selecting the replacement from the drop-down list. All library settings will then automatically be replaced by the ones of the understudy actor.

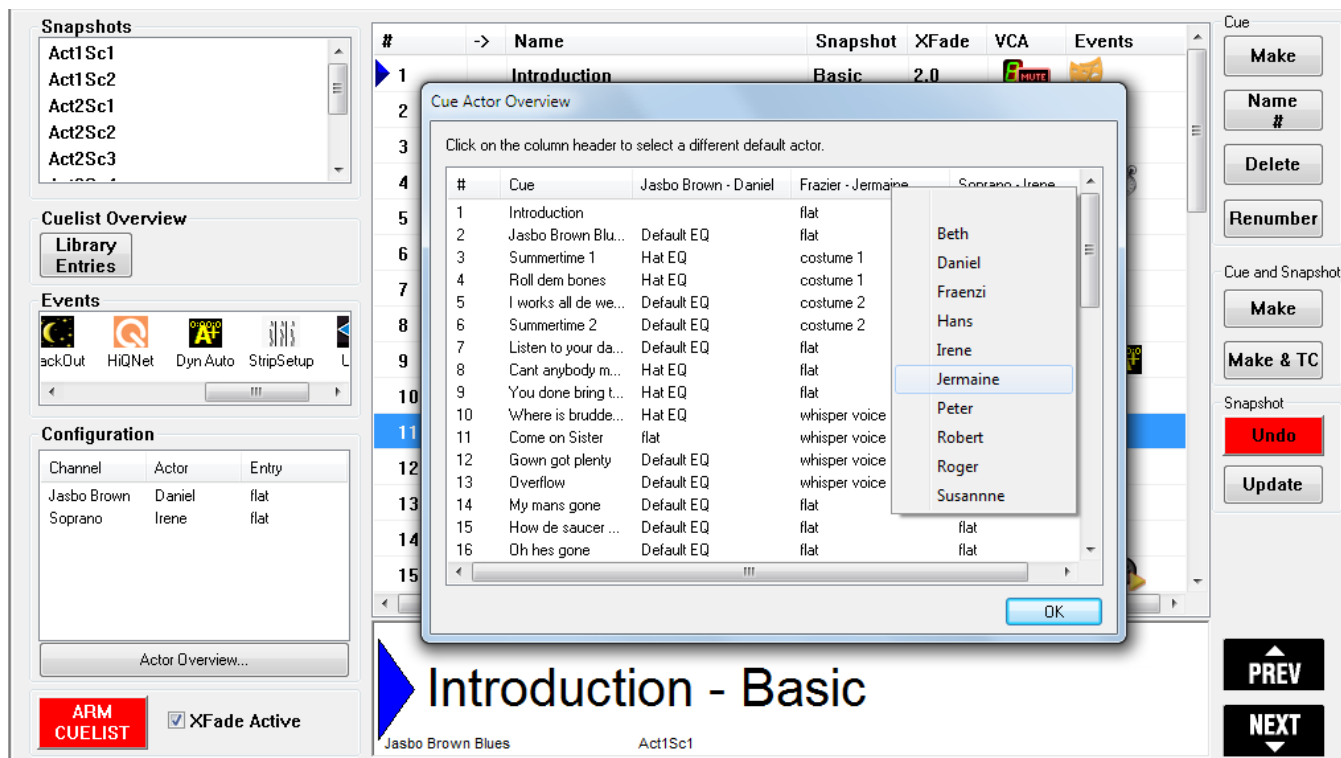

End Show Button There is an End Show button at the bottom of the clipboard library window. It is intended to be used at the end of a show performance, as the name implies.

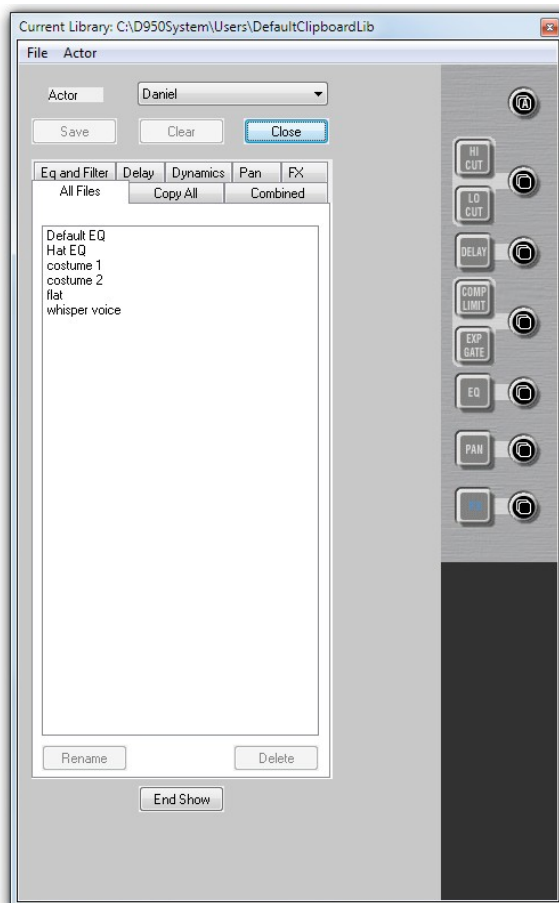

This button opens a list that displays all tweaked library event settings. It prompts the operator to decide whether he wants to save or discard these tweaks, either globally or setting by setting.

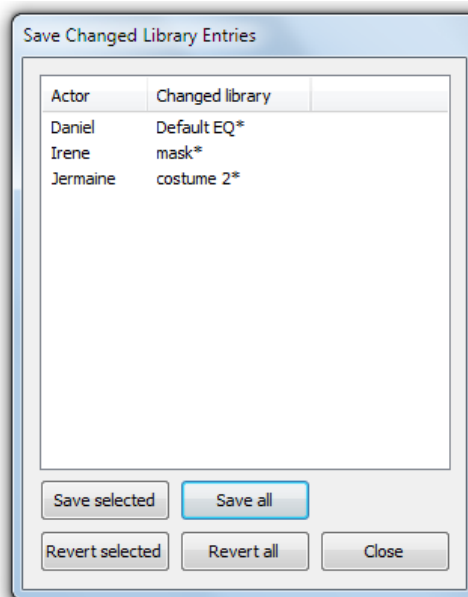

The End Show mechanism simply makes sure that no tweaked setting can be forgotten to be either discarded or kept. It may, of course, also be used during a show or a rehearsal in order to clean up the current changes.

If there are any tweaked settings or modified mute events that have not been saved already, there will appear a dialog box upon closing the clipboard library window, asking the user whether he wants to save the unsaved data. So again, no setting can be forgotten even if there is pressure of time.

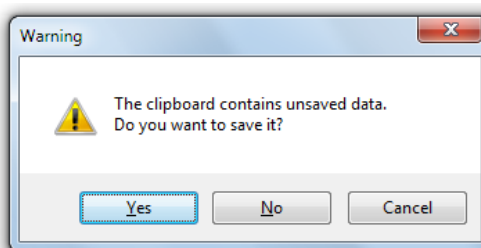

Also if the Vista application is closed down after the show and tweaked settings had not been saved, again the list that displays all tweaked library event settings is opened and prompts the operator to save or revert the changed settings.

4.4.6 Strip Setup

The Strip setup page can be called up in three different ways:

- From the **View** button, by clicking on the appropriate icon
- Using the *Quick Access Toolbar* icons, by clicking on the appropriate icon;
- Using the **STRIP SETUP** function key in the Control Bay of the Vista surface.

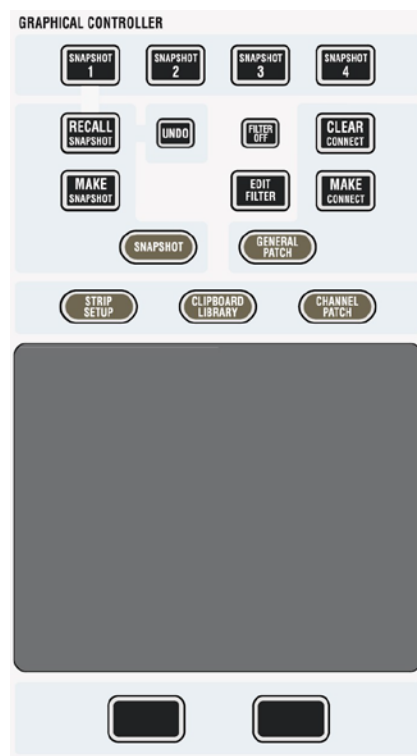

The Strip Setup page has a number of functions. Primarily, the 'Strip Setup' window allows the user to assign DSP Channels onto the Vista surface. It also gives a very good overview of the console and may be used during general operation of the console to help the user navigate around the console.

Please refer to [chapter 1.1.5](#) for information on navigation philosophy.

The Strip Setup page (see below) provides a representation of the six sections of the Vista 'virtual surface'. Although the concept of navigation is based on scrolling in a horizontal plane, the representation of the six sections is displayed in a vertical plane because of screen space. The navigation system allows the user to decide which area of the virtual console the Control Surface will represent. The number of bays within a section will automatically be identical to the number of physical bays of the control surface. In the example shown below, the Control Surface will have three fader bays – a total of 30 faders. The total number of virtual channel strips available to represent DSP channels is $6 \times 30 = 180$ in this example.

Channel Color Code Color is applied to aid the user in channel identification. The colors relate to the channel type being shown. These are consistent with the use of color for channel identification on the Vistonics screens.

Slow Channel Meters On the Strip Setup page there is also a representation of the channel meters, giving a (slow) overview of all input signals. Channel assignment corresponds 1:1 to the desk fader channels.

FaderGlow Colors As a thin frame around a channel strip, the FaderGlow color is also displayed in the Strip Setup.

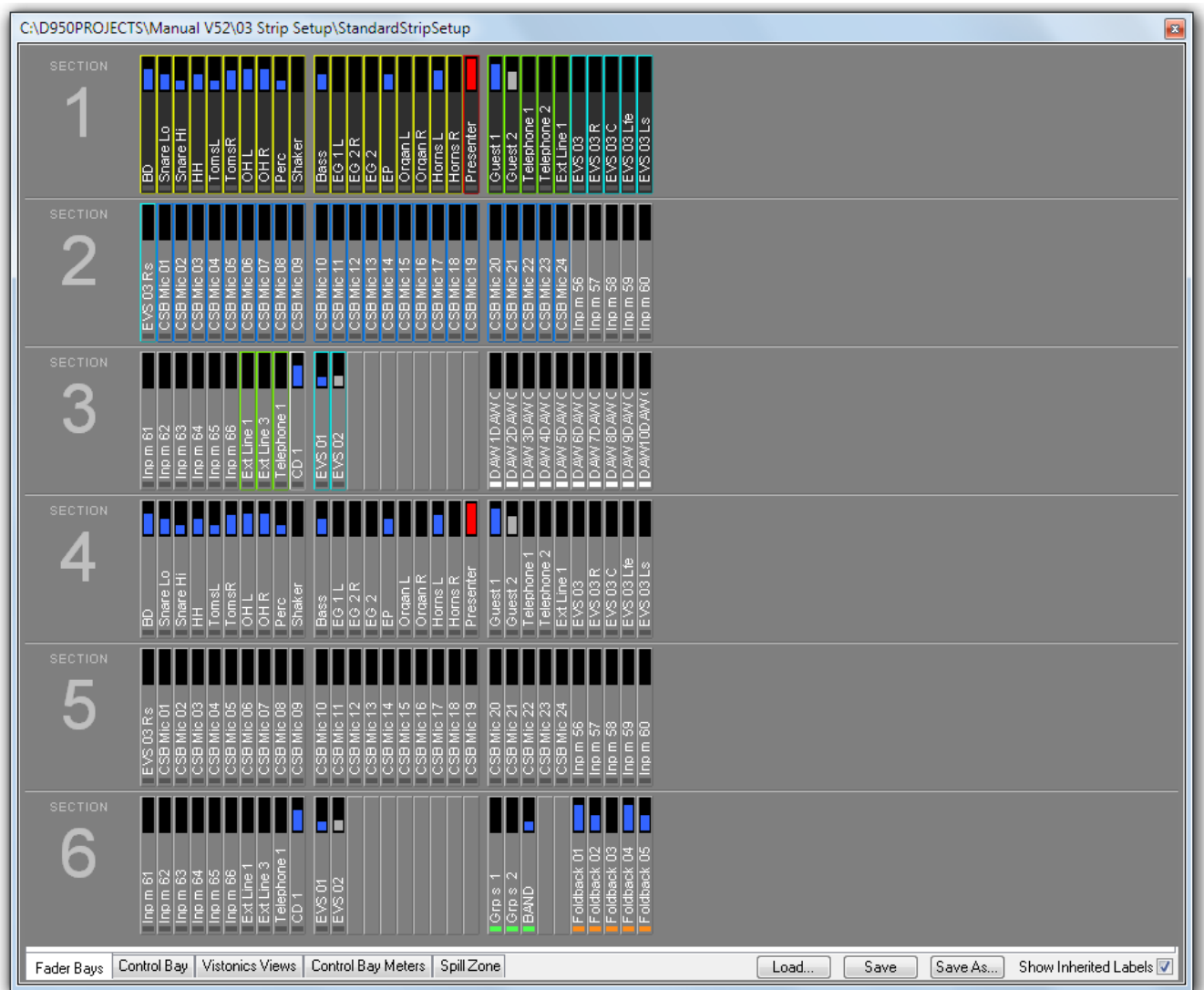

4.4.6.1 How to Use the Strip Setup

To create a new strip setup or to adapt an existing strip setup, first call up the strip setup page (see above).

4.4.6.1.1 Assigning a Single DSP Channel to a Single Channel Strip

To assign a channel to one of the virtual channel strips, right-click on the virtual channel strip that the DSP channel is to be displayed on. This will highlight the chosen channel and a selection menu will appear, listing all the categories of channel types. These are submenus that contain a list of the available DSP channels in the currently loaded configuration. Move the cursor to the drop-down menu of the desired channel type and select the desired channel from the list to assign it to the highlighted channel strip.

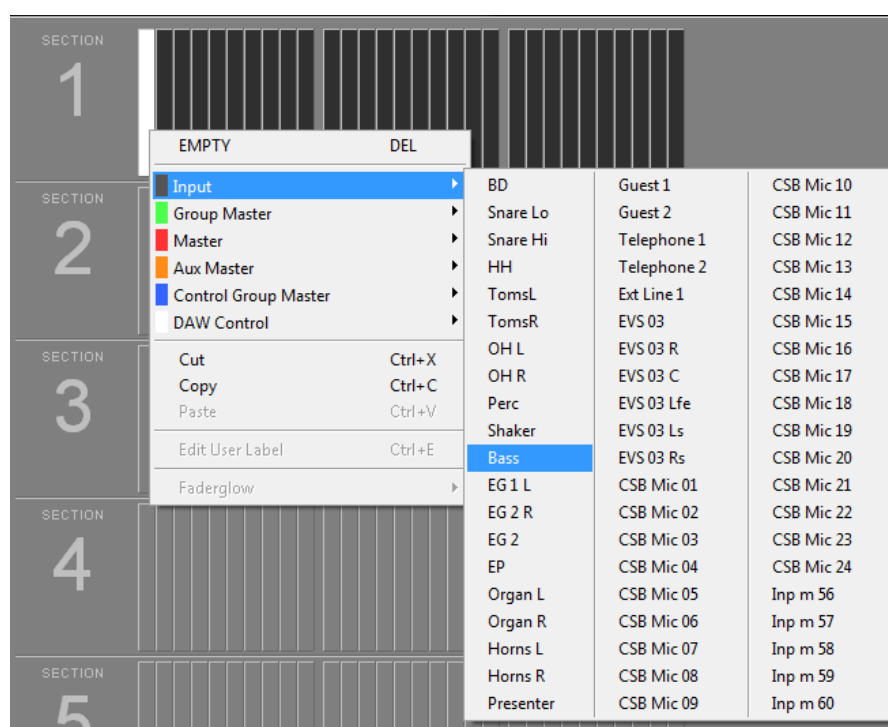

4.4.6.1.2 Assigning Multiple Channels in one Single Action

It is possible to assign consecutive DSP channels onto consecutive channel strips in one action. First use the hold and drag function of windows to select a number of consecutive channel strips. This will highlight the selected channel strips. Right-click on any of the highlighted channels to open the channel selector menus. Select the first channel of the consecutive channels to be assigned. Consecutive DSP Channels will now be pasted to fill the number of highlighted strips.

Tip By double-clicking on a single channel, the complete bay of 10 strips that the channel strip resides is selected. Three clicks on a single channel will select all channel strips within the complete Section.

4.4.6.1.3 Moving Already Assigned DSP Channels to Other Channel Strips

If a DSP channel is already assigned to a channel strip, it is extremely easy to change the channel strip on which it is shown. Simply click-and-hold the left touch pad button on the desired channel and drag-and-drop it onto any other channel strip. This will remove it from its present position and place it in the new channel strip. Whilst the left touch pad button is held with a selected channel, a 'ghost' view will appear to aid navigation to its newly selected channel strip. If it is dropped onto a channel strip which is already displaying a channel, the new channel will replace the existing one.

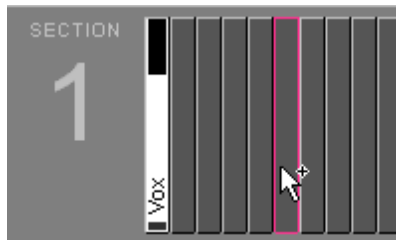

It is also possible to move numerous consecutive channels in one block by highlighting a number of channels. Click-and-hold the left touch pad button and drag-and-drop the channels to the new location. A 'ghost' view of the selected channels appears to help navigation.



Tips By holding the **Ctrl** key whilst dragging-and-dropping channels, the DSP channels will be copied to the selected destination, instead of being moved from their original position. Standard Windows copy/paste functionality (Ctrl+x for cutting, Ctrl+c for copying, Ctrl+v for pasting) is possible once channel strips are highlighted.

Note: If ten channel strips are copied or cut, and only five channel strips are highlighted to paste the DSP Channels into, then only the first five DSP channels of the copied ten will be pasted.

4.4.6.1.4 Useful Information

- Any DSP Channel can be assigned to any Channel Strip on the virtual control surface.
- Any DSP Channel can be assigned more than once to several different Channel Strips on any Section.
- It is not necessary to assign all DSP Channels available in the currently loaded configuration; then, however, there will be no control of these channels from the control surface.
- Assigning DSP Channels to Channel Strips has no affect on audio. It is purely a viewing function, and therefore changing the strip setup can be done at any time whilst operating the console.
- An indication is provided to highlight which bays are currently displayed on the physical console. These displayed bays are in dark gray.

4.4.6.1.5 Labels in Strip Setup

The most useful label type to show in strip setup is the ‘Inherited Label’. This is the session label of the source that is patched to a DSP channel and also relates to the large label in the channel strip display. See [chapter 4.4.2.6](#) for more information regarding the Vista labeling system. For this reason, a checkbox is provided which locks the label type view of Strip Setup to show the ‘Inherited labels’ (see below). Check the ‘Show Inherited Labels’ box to always show Inherited Labels in the Strip Setup window.

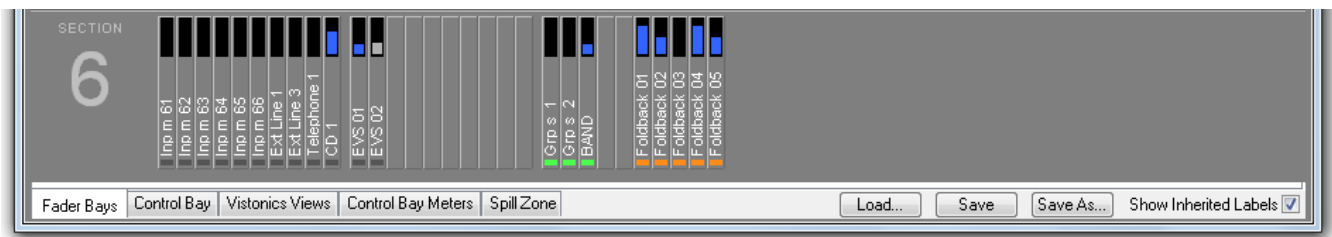

If the ‘Show Inherited Labels’ box is not checked, the label type shown in the Strip Setup will follow the choice of the label displayed by the smaller label in the Channel Strips. See [chapter 4.4.2.6](#) for a description of this label.

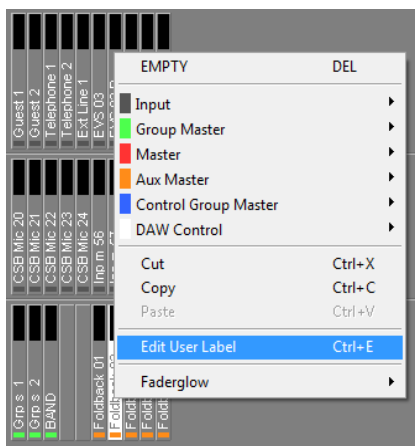

The following channel types can directly be labeled in the Strip Setup by right-clicking the desired channel, and then selecting Edit User Label.

- DAW channels
- CGM/VCA masters
- Aux masters
- Matrix masters
- Group masters
- Masters

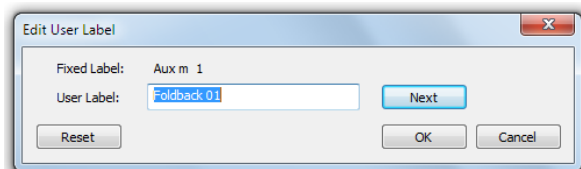

Important

Input channels are the only channels that cannot be labeled in the strip setup. This is because the input channels use a special mechanism always propagating the name of the Input interface (e.g. mic input) to the channel patched to

this particular interface. This is very helpful since the user names need not be relabeled whenever the patch is changed. Therefore, it is of no use when manually changing the user label of an input channel – it will always get overwritten automatically.

4.4.6.1.6 Metering

Strip Setup Window

If the 'Fader Bays' or 'Control Bay' tab is active, every channel displayed on the console surface also has a *slow* meter in the strip setup window that is a slow indication of signal activity at this channel's input. Color is used to identify the channel's status. A blue meter bar means that the channel has its fader open and is switched on. If the meter bar is gray, then the channel has a signal associated with it, but either the channel fader is closed or the channel is muted (off). If the meter bar is red, the channel currently is in overload status.

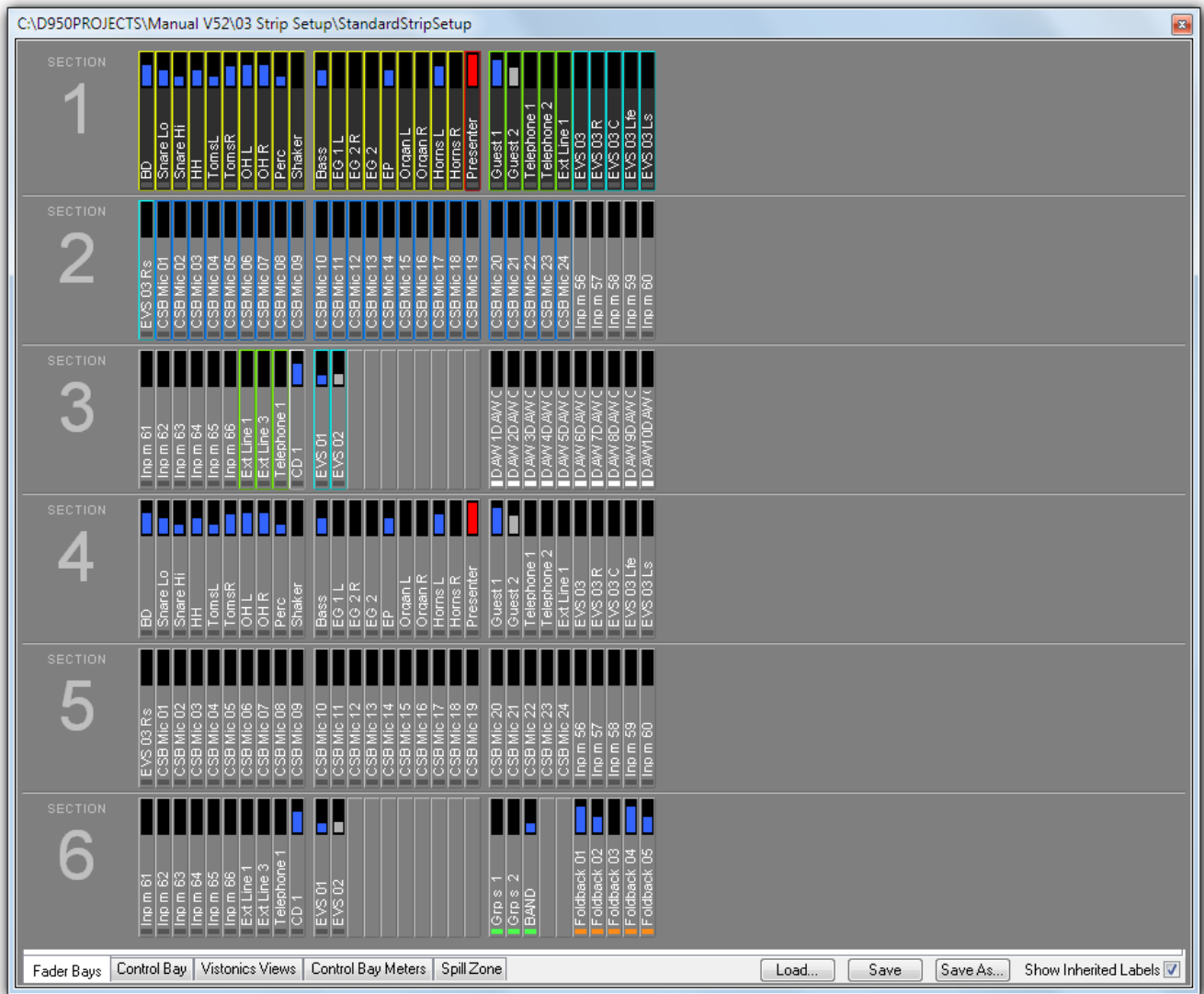

Fader Bay Meters

The default assignment of the TFT meters to the fader channel strips is 1:1. This may be modified by the system administrator only; if not logged in as system administrator, the ‘Fader Bay Meters’ tab is not displayed, and meter assignment is restricted to the control bay.

Assignment is done in the strip setup window. First, click the ‘Fader Bay Meters’ tab. The window changes to the view shown below. Entering channels is done with the same mechanism as is used for the assignment of channels to bays.

Changes in the channel assignment may be easily reset to the default setting by selecting ‘Reset to StripAssignment’.

Lower Meter Area

The default settings of the lower meter area are labeled ‘DEF’. These are the history view for mono and stereo channels, and the surround view for 5.1 channels.

When right-clicking into the lower meter area, the display mode of the lower part of the meter can be selected (‘HIST’ for the history display, ‘BUS’ for bus assignment view, ‘SRND’ for surround view, and ‘L2’ for layer 2 view). Options not available for a particular channel type will be grayed-out.

Changes made here may also be reset to the default setting by selecting ‘Reset to StripAssignment’ after a right-click in the upper meter area.

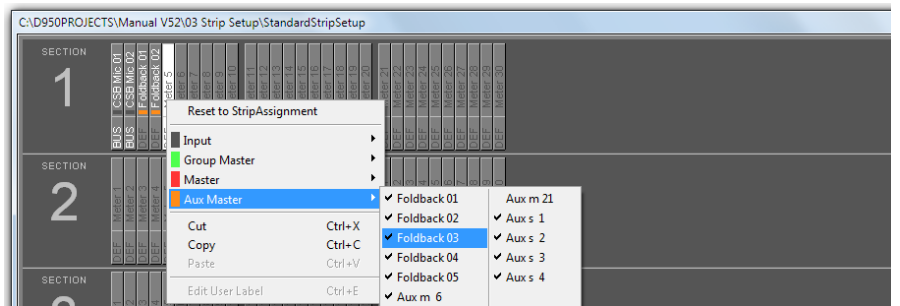

Control Bay Meters

Click on the ‘Control Bay Meters’ tab. The window changes to the view shown below. Entering channels is done with the same mechanism as is used for the assignment of channels to bays.

After selecting one of the ‘USER’ fields, the view corresponding to the user keys can be defined.

Please note that the two meters at the far right of the control bay are *always* used for PFL and CR monitoring and cannot be assigned to a channel.

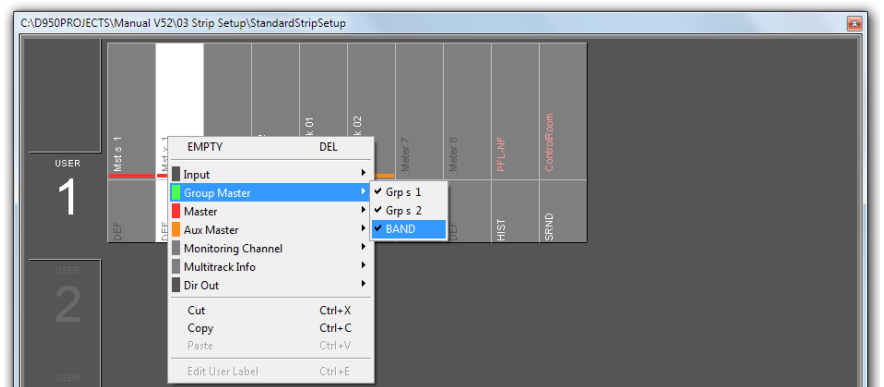

4.4.6.1.7 FaderGlow

The FaderGlow color assignment is performed in the strip setup as well.

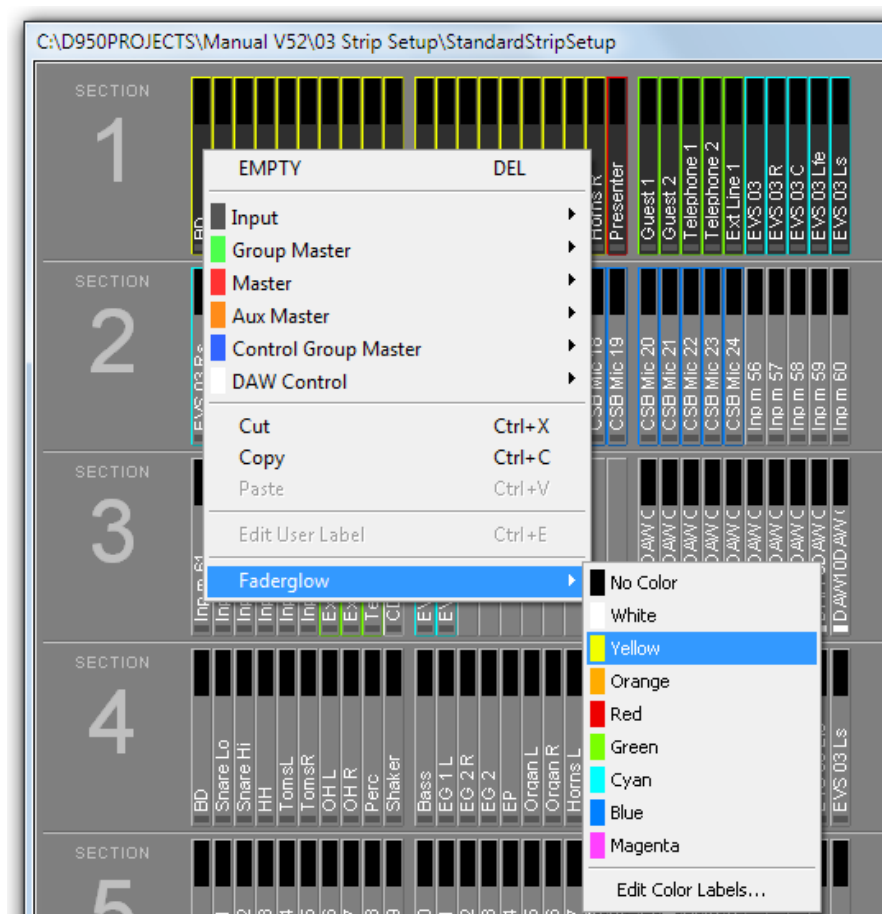

After a right-click on the desired channel, click on the 'Faderglow' item; a list will drop down offering the eight available colors and 'no color', i.e. FaderGlow switched off. In order to give the channels within the same FaderGlow color group a label, click on the 'Edit Color Labels' item. A menu with label entry fields for every FaderGlow color will open up.

The FaderGlow setup is saved as a part of the Strip Setup, allowing different operators who might alternately mix a show having their own, personal color setup.

4.4.7 Clipboard Libraries

On the Vista console it is possible to save and load clipboards to/from the external memory device. Clipboard files can contain one or more audio functions (e.g. EQ only, Dynamics only, or a combination of EQ and Dynamics) from a channel, or even can save complete channel settings. This is then representing a 'clone' of a channel, including bus assignment. By recalling such a channel from the clipboard library it is easily possible to bring the channels of a console into a certain status without even using snapshot functions.

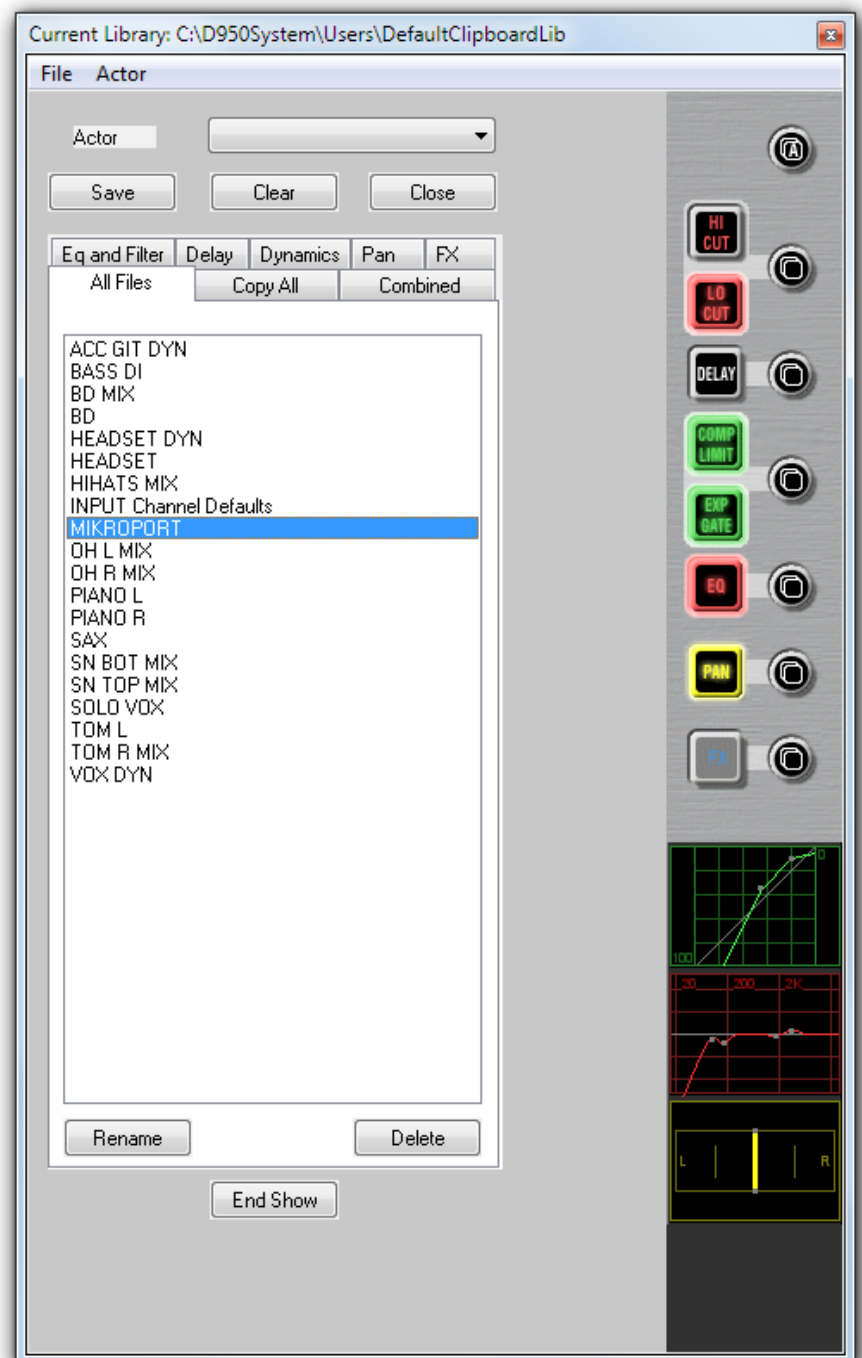

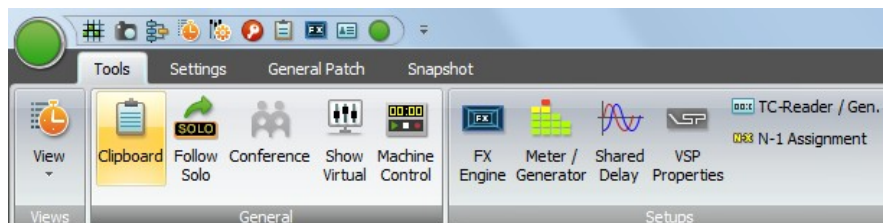

4.4.7.1 Clipboard Library Window

The Clipboard Library window is automatically opened whenever a paste function is pending on the Vista console. In order to open the window manually (e.g., to load the console clipboard with a saved value), select the **Clipboard** icon from the Tools menu or press the **OPTIONS F4** key on the console.





The window may be closed by clicking on the close box on the top right corner of the window, by clicking on the Close button, or by pressing **F4** again.

4.4.7.2 Paste into Clipboard Library

- 1 Press the  (Copy/Paste) key on one or more audio functions of any channel strip(s) on the console surface. The Clipboard Library window will be opened automatically whenever a paste operation is pending.
- 2 Click on the half-lit  button in the window. If multiple audio functions are pending to be pasted (e.g. EQ and Dynamics settings), it is possible to click on the half-lit  A (Copy/Paste All) button in the window. The pasted values will be graphically displayed.
- 3 The Save dialog opens, now you can give a name to the clipboard. It will be saved in the currently active Clipboard library.
- 4 Close the Clipboard Library window (see above)

4.4.7.3 Copy from Clipboard Library

- 1 Open the Clipboard Library window (see above).
- 2 If the desired library is not opened already (indicated in the title bar of the window), open the requested library by selecting 'Open Library' from the File menu.
- 3 Select the desired tab. Each of them represents a group of saved settings, which means that all listed files within a tab have the same type of audio function settings. 'All files' will show a list of *all* available clipboard files within this library, containing all the content of the other tabs. Files in the 'Combined' tab contain a combination of audio function settings. (e.g. EQ and Dynamics settings together). Files in the 'Copy All' tab contain complete channel settings.
- 4 Select a clipboard setting from the list by clicking on it. This will activate a preview function on the panel, shown at the right-hand side of the window. In this way it is easy to search for a special setting by looking at its graphical representation. The preview function lets you also identify which audio functions are contained in the selected clipboard file: The graphical representation of their 'On/Off' key will be grayed-out if there is no value present in this file.

- 5 Click on the  (Copy/Paste) button of the desired function in order to activate copying. The button will light, and all possible destination keys on the console surface will be half-lit. Shortcut: A double-click on the clipboard name in the list will activate copying of all contained audio values within that particular file directly.
- 6 Paste the value into one or more channels of the console, using the standard functionality. If the clipboard contained multiple audio settings, such as EQ and Dynamics, they may be pasted together by pressing the  A (Copy/Paste All) key of the destination channel.

4.4.7.4 Rename/Delete a Clipboard Library File



- 1 Open the Clipboard Library window (see above).
- 2 Select the file you want to change or delete by clicking on it. Click on the 'Rename' or 'Delete' button of the Clipboard Library window in order to execute the desired action.
- 3 Close the Clipboard Library window (see above).

4.4.7.5 Clear the Display

By clicking on the 'Clear' button, the previewed settings are cleared, and no graphical indication is shown on the right-hand side of the window.

4.4.7.6 Update a Clipboard File

To combine, for instance, the current dynamics settings of a channel with the EQ settings that are already in the library, and to save them as one new set into the library, proceed as follows:

- 1 Open the Clipboard Library window (see above).
- 2 Select the desired, already saved EQ setting by clicking on it once. The EQ settings will be displayed graphically on the right-hand side of the window.
- 3 Press the  (Copy/Paste) key in the dynamics section of the source channel on the console.
- 4 Click on the half-lit  (Copy/Paste) button in the dynamics section of the window.
- 5 Both EQ and dynamics values will now be displayed on the right-hand side of the window.
- 6 The Save dialog opens. Once saved, the new, combined set will now be displayed within the 'Combined' tab.
- 7 Close the Clipboard Library window (see above).

4.4.7.7 Storage Format

Each clipboard is saved in a file with a **.cpy** extension. Multiple **.cpy** files form a library. A **.cpy** file may contain only one audio function (e.g. EQ settings) or a combination of any audio functions of a channel (e.g. EQ and Dynamics settings).

4.4.7.8 Import a Clipboard File from Another Library

- 1 Select 'Import Clipboard' from the file menu.
- 2 Navigate to the desired library.
- 3 Open the desired `.cpy` file. It will automatically appear and be saved within the library currently active.

4.4.7.9 Where are Clipboard Libraries Saved?

If you don't want to maintain multiple libraries on your console, you never have to change or define a name; just start directly, using the library functionality. The system will then use a library called `DefaultClipboardLib`.

If there are multiple libraries, you may select 'Open Library' from the file menu of the clipboard window in order to select another library to work with. It is also possible to save the whole library under a different name or to save it to a portable storage device such as a USB memory stick by selecting 'Save Library' in this file menu. Selecting 'New Library' in the file menu creates a new, empty library.

In technical terms, a library is a subdirectory of the `C:\D950System\Users` directory, it may also be located within any other user subdirectory. Selecting 'New User' creates a new user directory containing an empty Library called `ClipboardLib`.

4.5 Second Level: The Application Menu

The application menu is opened by clicking on the round surveyor icon on the right top corner of the GC screen. It contains most of the Vista system's bookkeeping functions. Management of projects, titles and mixes, access to DSP configurations, backup and import functions, and also the Exit menu are controlled from here.

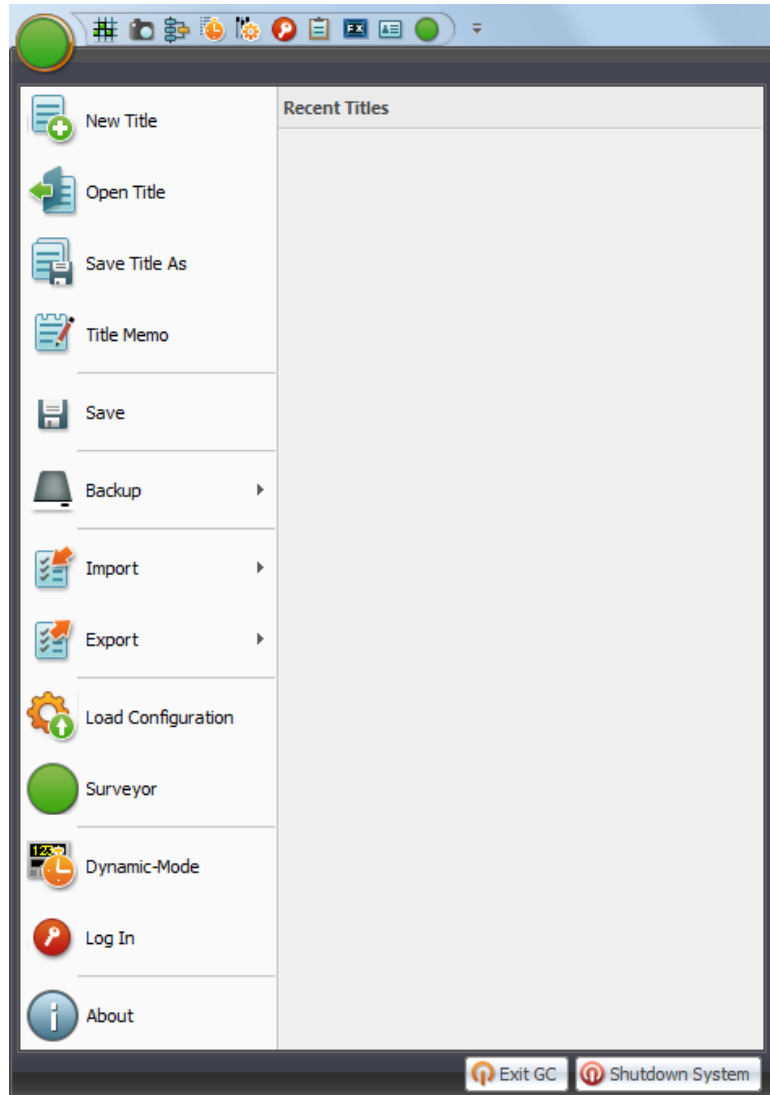

4.5.1 Titles and Projects

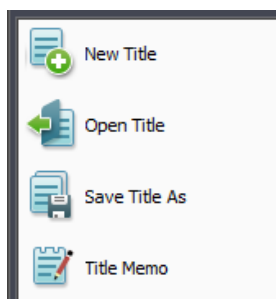

The *Title* is the main container for all the session data. Titles contain all snapshot, mix, cue list, title memo, and other files that relate to each session. Titles also contain pointers that recall the appropriate configuration, monitor file, and so on.

Titles are found in a project folder. Project folders may be created along with a new title. For example, a project folder might be created at the start of an album project when the title for the first song was made. Subsequent titles could be created for each of the other songs and placed in that album's project folder. Projects are located in the `D950PROJECTS` folder.

New Title This action opens a dialog box that enables the creation and selection of a name for a new project and/or title. You can freely create any number of projects and titles.

Let us assume you wanted to create a new project and title in the Subdirectory D950PROJECTS. Open the application menu , select New Title, and you'll end up with a familiar Windows box:

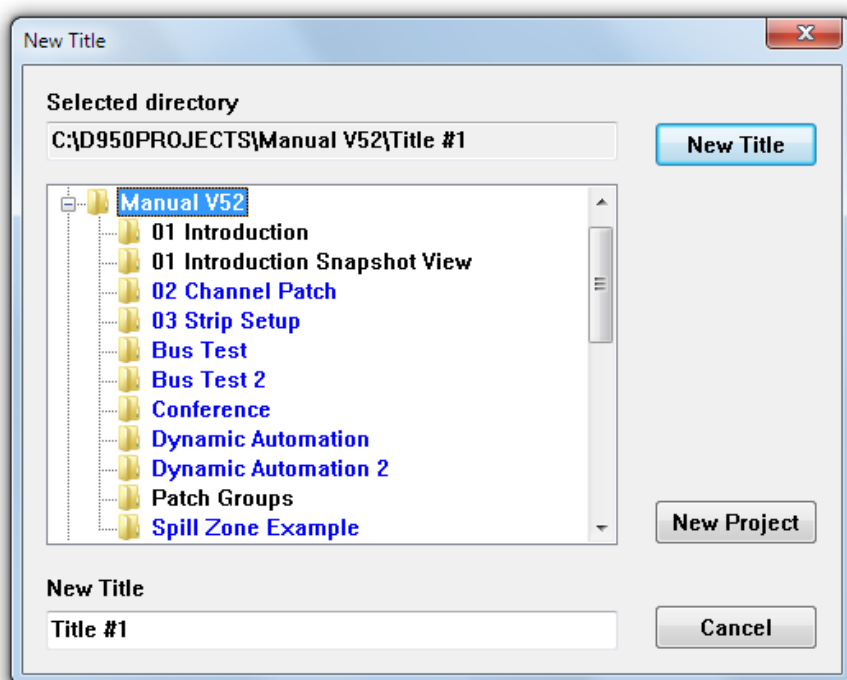

Click on the New Project button and a name entry box will appear. Type in a new project name – for example, *CITY TV1* – and click OK. A new folder with the name you just entered will appear in the list. It will be highlighted in gray, indicating that it has been selected to receive new titles. The New title name entry field (at the bottom of the box) will now automatically display *Title #1* (or the next available number). This will be highlighted in blue, indicating that it is ready to be over-written with a proper name, for example, *BLUES CITY*. Once a new title name has been entered, click the New Title button or press the Enter key. These actions will perform the following:

- Creating a new project subdirectory (C:\D950PROJECTS\CITY TV1);
- Creating a new title subdirectory (BLUES CITY) within the CITY TV1 project folder (C:\D950PROJECTS\CITY TV1\BLUES CITY);

- Creating the necessary title-oriented files that are saved within this title subdirectory;
- Display of the current title name in the title bar.

If you do *not* create a new title, all your subsequent data will be saved in whichever title is currently open. If a title is not currently open you will be prompted to open or create a new title before data can be saved.

Tip You should generally organize your Subdirectories in such a way that C:\D950PROJECTS remains the *parent* directory, because the system automatically searches for that particular directory while opening projects, titles, etc. After several weeks of using the Vista system, your directory structure may create something like this:

| Parent | Your Projects | Your Titles | Your Data |
|-----------------|---------------------|--------------|---|
| C:\D950Projects | \SuperProductions_1 | \FirstSong | \FirstSong.tit \Snap1 \Snap2 |
| | | \SecondSong | \SecondSong.tit \Snap11 \Snap12 \Mix1 \Mix2 |
| C:\D950Projects | \SuperProductions_2 | \EveningShow | \EveningShow.tit \SnapBaby \SnapBaby_new \Mix |
| C:\D950Projects | \SuperProductions_3 | \MorningShow | \MorningShow.tit \CoffeSnap_1 \CoffeSnap_2 \MyNewMix |

...and so on.

Open Title This action opens the list of project folders from the D950PROJECTS directory. This enables the selection and opening of an existing title from a selected folder. Titles can also be deleted from this menu item.

To open an existing title, first double-click on the desired project subdirectory, an action that will move you into its Subdirectory:

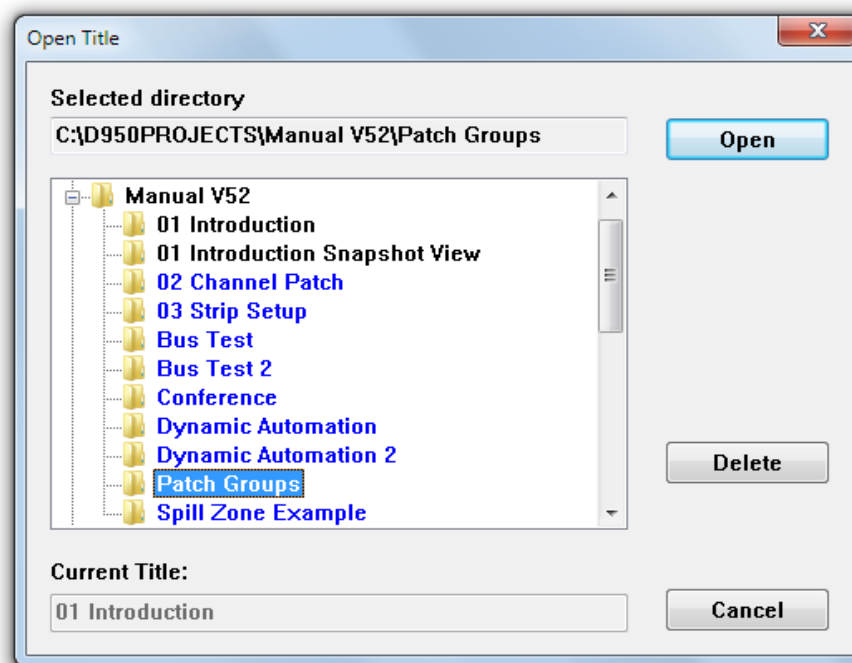

The desired title can now be opened by double-clicking on the title folder or by highlighting it and clicking the Open button. This action will perform the following:

- Make the new title the *current* title, making available all snapshots, mixes, etc;
- Indicate the current title name in the title bar.

A title can be deleted by highlighting a title's name (while in Open Title) and clicking on the Delete button. You will be asked to confirm this action. You cannot directly delete a project folder using this technique. However, if you delete the last title from within a project folder, you will be notified that the empty folder will be automatically deleted.

Note Titles are color-coded according to the status of the DSP configuration that was in use during their creation. Black, blue, and red title names indicate the following:

Black The DSP configuration needed for this title is currently loaded;

Blue The DSP configuration needed for this title is not currently loaded.

Save Title As... Opens a Windows dialog box allowing to select a new name and to save the current title's data under a new name. The process is similar to 'New Title' because it creates a new title under a new name. The difference is that it also copies all the snapshots, mixes, etc., from the current title into the new title. So, it will do the following:

- Create a new title subdirectory with the new name;
- Copy all data from the current title into this subdirectory;
- Make the new title the *current* title;
- Indicates the current title in the title bar.

To save a current title under a new name:

- Select Save Title As... from the File menu;
- Highlight the desired project Folder;
- Type an appropriate title name in the entry box;
- Click on the Save button or press the keyboard Enter key.

Title Memo The Title Memo editor page allows any relevant title information to be kept for later use. There is one Memo per title. Its contents can include Studio name, Producer Name, Engineer Name, Artist Name, plus a free-form Memo pad. The title directory location and modification date/time are displayed at the top of the title memo page.

To open the title memo, open the application menu and select Title Memo.

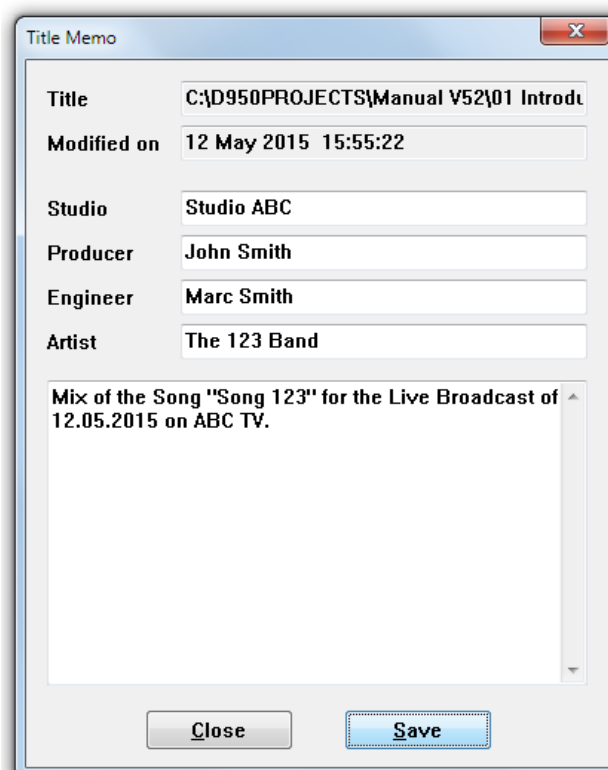

Note: The title memo *has no function key* on the control surface keyboard.

4.5.2 Save

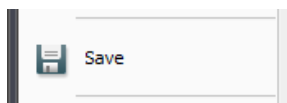

Selection of the Save menu item will save all title oriented information to the currently opened title.

Since this happens automatically when changing to another title or when leaving the application, this button possibly may never be used.

4.5.3 Make/Restore Backup

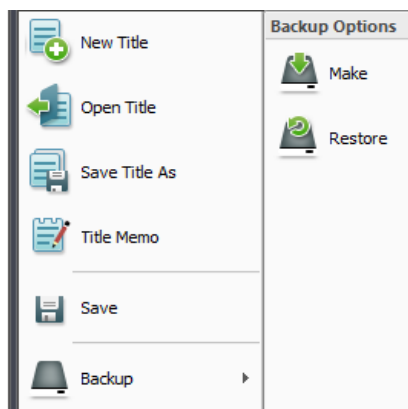

The Vista provides a powerful and easy-to-use data backup utility. This feature enables the creation of a backup subdirectory that contains a copy of all files from the title folder and all pertinent configuration and system files needed to recreate the session on this or another Vista. These backup files can be used for data protection and easy transportation of titles between Vista equipped facilities.

Backup directories can be made on any storage media of sufficient size. They can be used to restore all of the files and information needed to recreate the title at a later date or on a different Vista.

Make Backup

This action opens the Create Backup window, where a destination for the backup directory is selected. backup directories are automatically named by the utility. After the BCK_D950_BACKUP... portion of the title, names include the title name and dates of modification and origination.

To create a backup directory for the current title:

- Select Make Backup from the Application menu;
- Select the destination for the backup directory;
- Click the OK button or press **Enter** on the keyboard

These actions will perform the following:

- Creation of a new backup directory at the desired location;
- Name and date the directory.

Restore Backup

This action opens the Restore Backup window entitled, where a backup directory is selected for reloading.

To restore a backup directory:

- Select Restore Backup from the Application menu;
- Highlight the desired backup directory;
- Click the OK button or press **Enter** on the keyboard;

A pop-up dialog box will appear giving you the option of replacing the existing title, saving the restored title as a new title, or canceling the backup. If you select 'Replace the Existing Title', you will not be able to replace the Session Configuration if it is currently loaded and will be given the option to continue. You will also have the opportunity to replace the monitor file if it also exists. Choosing 'Restoring the Title As' will result in the normal Window's save screen.

Notes

Regardless of the method used to create it, after a backup has been restored, the resulting title must be opened before use.

If you move production data between different consoles, it is advisable not to restore certain files onto the destination console, since it may have different hardware. This is valid in particular for the `monitoring.ini` files. You will be asked whether you want to restore these files as well; in this case answer negative if the two consoles are not identical in terms of monitoring.

4.5.4 Import

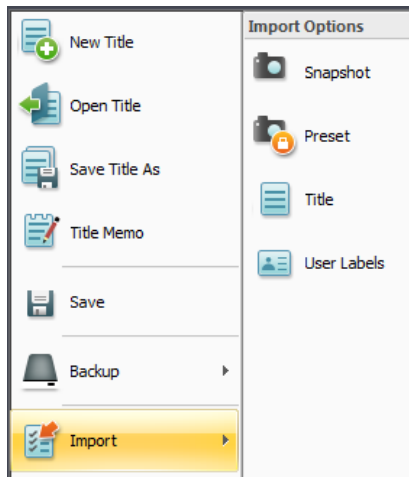

Using the Import utility in the Application menu, snapshots, presets, mixes, titles and user labels can be imported.

Import

This action is used to select the type of data you wish to import. Once the type of data is selected, an open window appears allowing to select the data source. The following rules apply when using the Import utility:

- Snapshots and mixes can only be imported into an open title
- Imported presets will be saved with the current DSP configuration
- Items can be renamed as they are imported
- A title will need conversion if it is imported for use with a different DSP configuration

Note

Importing a snapshot, preset, mix, and/or title will not automatically make it the current one. For example, a snapshot will not be applied to the console upon being imported. It must be recalled, in addition, using the snapshot page.

4.5.5 Export

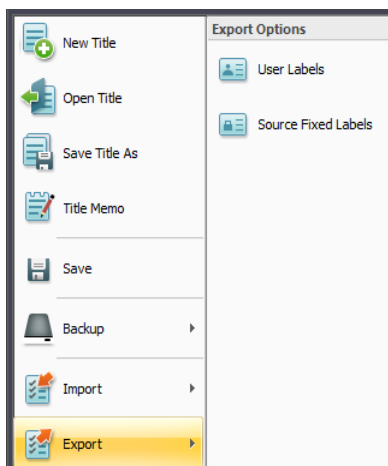

Using the Export utility in the Application menu, user labels as well as the fixed labels of sources can be exported.

To export fixed labels of sources can be useful when creating ProBel configuration files.

4.5.6 Load DSP Configuration

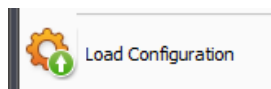

If there is more than one DSP configuration on your Vista system, you may need to access this menu item in order to load a different configuration. Since titles will automatically open the correct DSP configuration (if its not already loaded), using the Load Configuration menu item is only necessary when loading a configuration without opening a Title. Regardless of how a configuration is recalled, this process takes 20 to 30 seconds to complete, and mutes the console during loading.

Note: Keep in mind that all Titles contain pointers that enable the loading of the proper DSP configuration and other appropriate files. If the Title's DSP configuration is different from the one that is currently loaded, you will be asked to either confirm the loading of the correct configuration or to convert the Title for use with the current one. Therefore, during routine operation, it is not necessary to use the Load Configuration menu unless the user has created or modified a DSP configuration during that session. Typically, the Load Configuration menu item should only be used by the facility's System Administrator or by advanced users.

DSP configuration subdirectories reside in the `C:\D950SYSTEMDB` subdirectory. These subdirectories contain the following files:

- Virtual Mixing Console (VMC) files: These files (with *.vmc extensions) are created by the Session Configuration Tool. They contain all the Configuration data needed for the Session Configuration Tool to create a core file;
- Core files: These files (with *.cor extensions) are created by the Session Configuration Tool. They contain the actual code used by the DSP core (SCoreLive);
- Xml files: The Xml Configuration and VmcMappingInformation - files (with *.xml extensions) are created by the Session Configuration Tool. They contain the actual definition of the processing used by the DSP core (Infinity Core). Also the file MixercloudPaths.txt belongs to this category of files used by the Infinity Core;
- Preset files: These files (if any exist) are created within Titles but are saved with DSP configurations so they can be used with any Title that uses a particular configuration. Preset files have .pre extensions.

Load Configuration: This action opens a dialog box that allows the selection and opening of an existing Session Configuration. A list of available Session Configurations for selection will be displayed.

Tip You should generally organize your DSP configurations in such a way that `C:\D950SYSTEMDB` remains the parent directory, because the system automatically searches for that directory during opening of a Title or Session Configuration.

To load a configuration, double-click on it, or highlight it and click the Open button. This will do the following:

- Mute the console's audio paths (including the monitoring section);
- Load the appropriate VMC data (core file) into the system, and check their validity;
- Erase the old Session Configuration DSP software from the Flash EPROM in the DSP Core, and load the new DSP software;
- Reload the control surface desk (the Channel Strips will go blank for a few moments);

- Load the appropriate Monitor Configuration file;
- Activate the last used preferences belonging to the newly loaded Session Configuration.

Notes: When a configuration is loaded via the Load Configuration menu, the currently open Title will be closed; no new Title will be opened. Before any data can be saved using the newly loaded configuration, an existing Title must be opened or a new one must be created.

If a DSP configuration is displayed in red this means that this configuration has not been compiled properly by the Session Configuration Tool. Either run the tool again or delete this configuration.

4.5.7 Surveyor



Clicking the Surveyor menu item opens up the Surveyor window which show the current state of the system. Please see [chapter 4.8](#) for a complete description.

The same Surveyor window is also opened when double-clicking on the Application menu Surveyor icon.

4.5.8 Dynamic-Mode

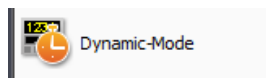

This menu item closes the Vista application, and restarts it with the same title, but in the Dynamic Automation mode.

This operation mode then provides functionality for dynamic automation of console elements against timecode.

Please note that in dynamic automation mode, the static snapshot automation functionality is not available.

4.5.9 Log In (as System Administrator)

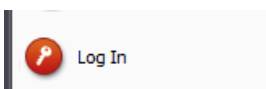

Lets the operator log in as System Administrator by entering a password (if defined at all). All greyed out SysAdmin menu items then become accessible.



Once logged in, this menu item automatically becomes the Log Out function, which allows to leave the System Administrator mode again.

Refer to [chapter 4.7](#) (system administration menu) for more details.

4.5.10 About

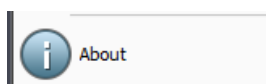

When selected, this menu item displays information pertaining to that specific Vista installation. This includes the software Release Number (version) and the Build Number.

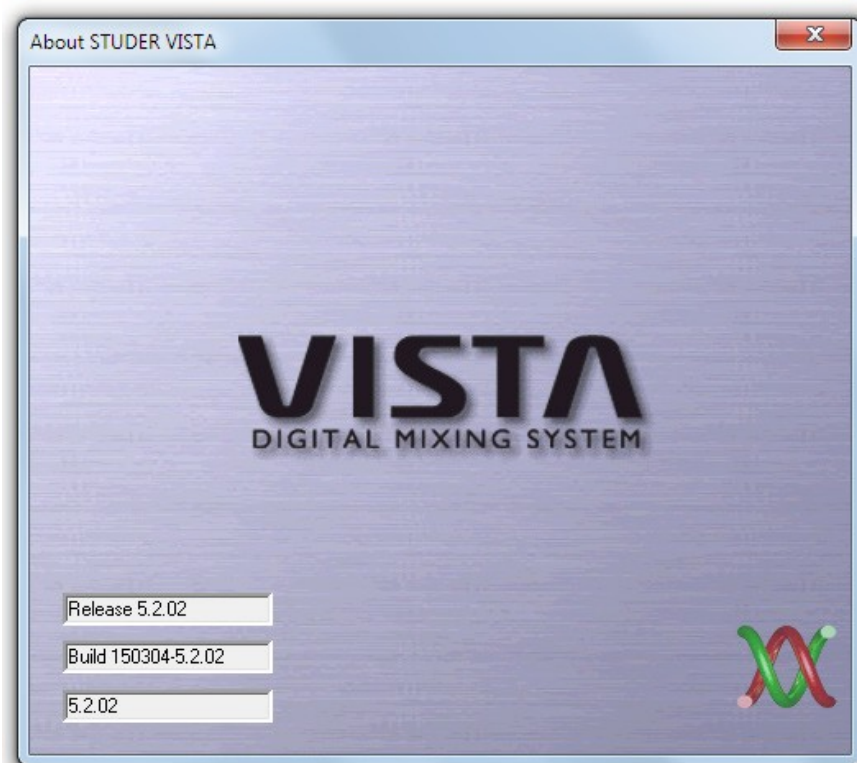

4.5.11 Exit Vista Application





There are three possible ways of quitting the Vista Software application. It is recommended to use the Application menu's *Exit* items : **Exit GC** or **Shutdown System**.

Exit GC This action will close the graphical controller (Vista system application) while simultaneously muting all monitoring outputs, and returning to the Windows NT operating system. All other programs and applications continue to run.

Shutdown System This action will close the graphical controller (Vista system application) while simultaneously muting all monitoring outputs. It also quits all other running applications and the Windows operating system. The desk PC will then be switched off.

In case an UPS (Un-interruptible Power Supply) is installed, and the associated utility is configured to do so, this will also turn off the UPS/PC combination automatically after a pre-set time period.

Using Main Window Control It is also possible to quit the Vista application by clicking on  main window control. There is no confirm box in this case, and the application is terminated immediately.

It could be potentially dangerous for your session if you click  main window control, because the application will be terminated, and audio will no longer pass. However, the data that was in use will be written to the 'last known session' and 'shutdown' files and will not be lost.

Note: It is possible for an expert to adjust settings in order to make the  close box disappear.

4.6 Third Level: Tools and Settings Ribbon Tabs

4.6.1 The Tools Ribbon Tab

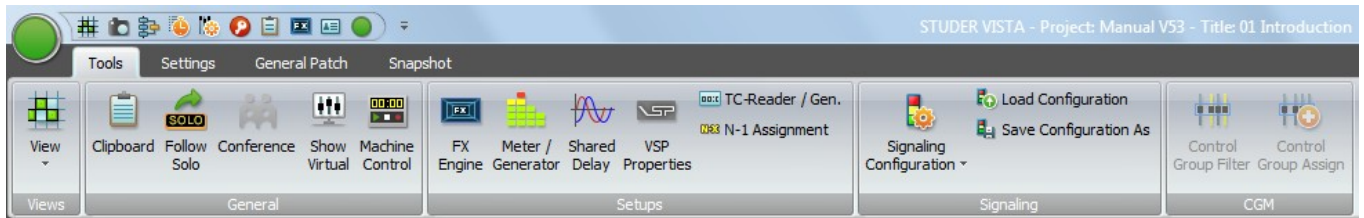

The Tools Ribbon Tab is divided into four categories :

- **General** (Menu items of general usage)
- **Setups** (Menu items for system setup purposes)
- **Signaling** (Menu items concerning signaling configuration)
- **CGM** (Menu items for Control Group Master setup purposes)

4.6.1.1 General

4.6.1.1.1 Clipboard

Clicking on this menu item opens up the clipboard library window (please see [chapter 4.4.7](#) for details).

4.6.1.1.2 Follow Solo

By clicking on this button, the Follow Solo Mode gets activated. This is a global setting which is valid for all titles and remains active until the **Follow Solo** button is clicked again, even if the Vista application had been closed and restarted in between. (Please see [chapter 2.6.18](#) for details)

4.6.1.1.3 Offline Conference

Clicking on this menu item allows to activate or deactivate a offline conference.

When configuring the N–X buses, a subset of N–X owner channels may be defined to be members of a conference. Whenever their fader is closed, they will automatically hear all other members (without hearing themselves back), rather than the normal N–X signal. As soon as the fader is opened, they will instantly hear the N–X signal again.

Offline Conference Setup



By pressing the **SETUP CONF** key on the control bay, the console is put into conference setup mode. The **LINK / SEL** keys of all possible conference member channels (all N–X owner channels) are half-lit, and the user may select any number of them to be members of the conference. If the user wishes to adapt this setting frequently, he may even stay in this mode during a live production, since the channels are instantly added or removed from the conference when pressing their **LINK / SEL** key (however, other features such as ganging will not be available while in setup mode).

All the channels currently defined as conference members are marked in the strip setup window.

The conference icon in the Tools tab has (only two) states:



Grayed out : No conference active nor defined



Grayed out : Conference active (if member faders closed)



Grayed out, crossed out : Conference defined, but temporarily deactivated (even if member faders closed).

Note: In certain circumstances, also an AUX master can be selected as a conference member (indicated by its half-lit LINK / SEL key). This is intended for adding e.g. an on-air signal to the conference. See details below.

Talk to the Conference

When pressing the TALK key on a channel which is currently conferencing, the talk function is automatically activated *on all members of the conference* at the same time.

Temporary Conference Deactivation

The conferencing may temporarily be deactivated by clicking on the conference icon  in the toolbar or the CONF ON key. In this case the conference definition is retained. As soon as the conference is reactivated globally (by pressing CONF ON or clicking on the conference icon in the toolbar again), the previously selected channels may talk to each other again. Temporary activation of the CONF ON key is possible as well.

Conference Level

While in conference mode, the N–X send level of the channel conferencing may be adjusted. This level will then be used as a conference send level only. When opening the fader, the level previously set returns. In other words, the system remembers two level settings; one of them is active when conferencing, the other one is activated in normal N–X mode.

Monitoring the Conference Using the MPX Bus

Within the new Configuration Editor software, the MPX bus type has been added. This bus only exists once within a configuration (similar to a PFL bus) and is used to monitor the conference. It is a mono bus. Any channel currently conferencing is automatically assigned to the MPX bus, and the MPX bus output may be monitored using a source selector key. Since the MPX bus output is a normal bus output, it can also be patched to any console output. This allows, for example, feeding this signal to a small loudspeaker for constantly playing back the conference signal.

Adding On-Air Signal to the Conference

It is possible to add an amount of the master signal to the conference, in case the conferencing members should want to constantly hear what's happening on air. This functionality is provided by a special function, whereby an auxiliary master channel is added as a conference member. This AUX bus is fed by the on air signal from the masters.

Procedure: Have one AUX bus configured with an On/Off symbol at the master channels. Have another On/Off symbol between this master channel and all N-X buses (this step is normally performed by the N-X wizard available in the Configuration Editor software.)

Define your conference members by pressing **MPX** and selecting any of the half-lit N-X owner channels, and add the AUX master channel as a further conference member.

Go to the console master channels and open some level to this AUX bus.

Vary the N-1 send level on the corresponding AUX master channel in order to add the on-air signal to the conference. Since this feed is taken pre-fader, this master's fader has no effect.

Typically, one auxiliary bus is reserved for this use. It may be the one with the highest of all bus numbers, in order to avoid confusion with the rest of the buses. By using the new 'N-X setup' wizard within the Configuration Editor software, this functionality can be easily added with all typical settings.

Alternate Signal to N-X Outputs (CUE)

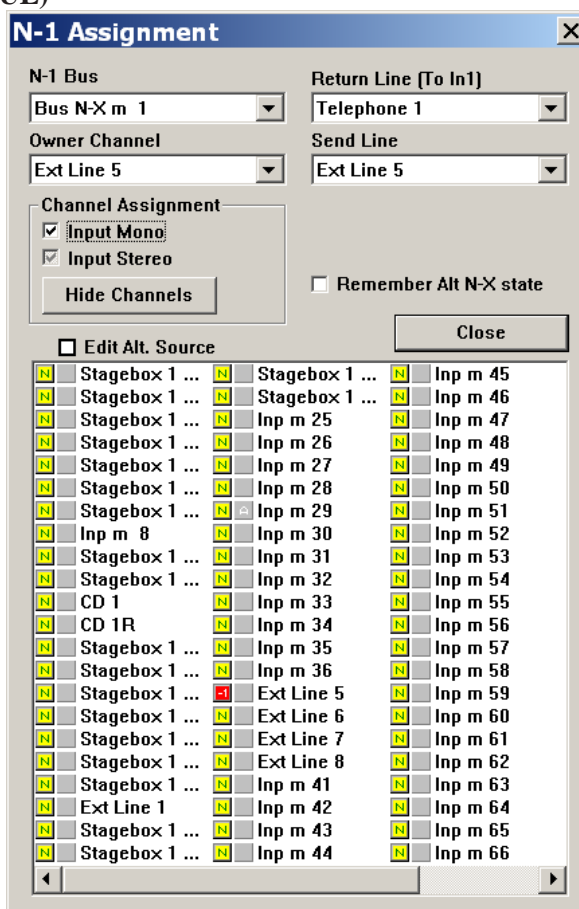

The new N-X bus type allows defining an 'alternate N-X bus assignment'.

It is possible to select any console channel (or multiples) to be the alternate N–X output signal. This signal is activated by the ALT n-1 key on the channel strip. This can be done only if the owner channel's fader is closed.

If you don't want to use normal console channels to be the alternate signal, feel free to configure simple input channels not used otherwise during the production. Such a channel can be the 'alternate cue signal' source for all N–X buses – or you can define a different alternate source for each N–X bus separately.

Set-up an 'alternate N–X signal' for a specific N–X bus:

- Open the 'Option: N–1 Assignment' menu in the Graphical Controller screen
- Select the N–X bus you want to define the alternate signal for
- Check the **Edit Alt. Source** checkbox
- Select any channel (or multiple) to be the alternate signal source for the selected N–X bus (their pre-fader signal will be used that can be weighted with the 'N–1 send level' to form the alternate signal for this N–X bus).

Note To avoid having to repeat this process too often, such a setup may be saved in a snapshot or preset to be used at any time by all operators.

Option *to bring back ALT N–X status upon closing fader.*

Option active (☑): The signal will switch back to ALT N–X upon *closing* the fader again, in case it was active before opening. This allows e.g. feeding an off-air signal to the outside lines while there are not on air (e.g. output signal from on-air console including commercials). Result: When the fader is opened, the outside lines get the normal N–X signal; when closed they are switched to the off-air signal.

Option inactive (original behavior): If the ALT N–X key (i.e. USR 1 or USR 2 key defined above) was active and the fader was opened, the return signal would automatically switch to normal N–X. After the fader is closed again, the signal would stay on N–X.

4.6.1.1.4 Show Virtual

When using the Virtual Vista application, this item brings up the virtual desk window and provides access to faders and other desk controls. The GC screen is then moved to the background. (This icon is greyed out when working on a console).

4.6.1.1.5 Machine Control

This menu item brings up the Machine Control window. In case the desk is not equipped with a hardware transport control panel, this software panel allows to do transport control, e.g. for playback devices connected via Sony P2 transport control interface, or also for transport control of a DAW via DAW-control.

4.6.1.2 Setups

4.6.1.2.1 FX Engine

If there are optional Vista FX units connected to the system, this button allows to configure the FX structure to be used within the current title. For details please see [chapter 9](#).

4.6.1.2.2 Meter/Generator

The Meter/Generator page is used for adjusting various settings of the desk channel strip metering and test generator. Generator defaults are automatically saved in the `D950system\shutdown.pfc` file when quitting the system, so that the *last used* defaults are available after the next start of your system.

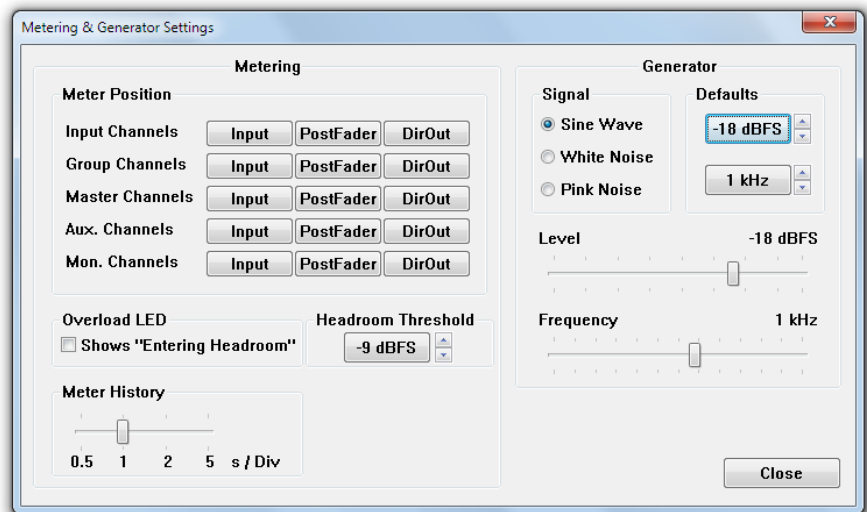
**Metering / Meter Position**

This action globally sets the metering signal source for all the channels of the same type to the same point within the signal path. It is usual to set the Input Channel and Monitor Channel meter sources to Input and those of the Group, AUX and Master Channels to the Post-Fader position. However, meter positions may be changed on a channel-by-channel basis and saved with snapshots and presets.

Metering / Overload LED

If 'Shows Entering Headroom' is ticked, the Overload LEDs on the channel strips as well as the red overload sign on the TFT screens illuminates when the signal level enters the headroom set with 'Headroom Threshold' instead of an overload condition.

Metering / Headroom Threshold

The desired headroom can be set here; this setting doesn't make any level changes but just sets the threshold level of the bargraph meters. Default setting: $-9 \text{ dB}_{\text{FS}}$, i.e. 9 dB below clipping occurs.

Metering / Meter History

This slider allows setting the speed of the meter history view in four steps from 0.5 s/div (fastest) to 5 s/div (slowest). Default: 1 s/div.

Generator / Level

Sets the test signal generator's level to the desired value. Levels can be set to off and, in 1 dB steps, from -90 to $+10 \text{ dB}_{\text{FS}}$. The Generator Level can be turned off by moving the Level slider all the way to the left.

Generator / Frequency

Sets the test signal generator's frequency (sine wave only) to the desired value. The generator frequency can be set in $1/12^{\text{th}}$ octave steps from 19.95 Hz to 19.95 kHz.

Generator / Signal Selects the waveform of the test signal generator, from Sine Wave, White Noise, and Pink Noise.

Generator / Defaults Sets the test signal Generator's level and frequency defaults by using the arrow buttons to adjust the default values.

To quickly apply a level or frequency default, rather than to adjust it manually, click on the appropriate Defaults button. Default levels can be set in 1 dB steps, from -90 to $+10$ dB_{FS}. The Generator Level cannot be turned off from the Defaults controls. Default frequencies can be set in 1/12th octave steps from 19.95 Hz to 19.95 kHz.

Tip By default, the Test Signal Generator is patched to GEN (the third channel input) of all channels. It also appears as a signal source in the General Patch and can be patched from there to any desired target.

4.6.1.2.3 Shared Delay

The settings of the Stereo and Multi-format Monitoring Delays (for control room, PFL, headphones etc.) are made in the same dialog window where the 'Shared Delay' processes are set.

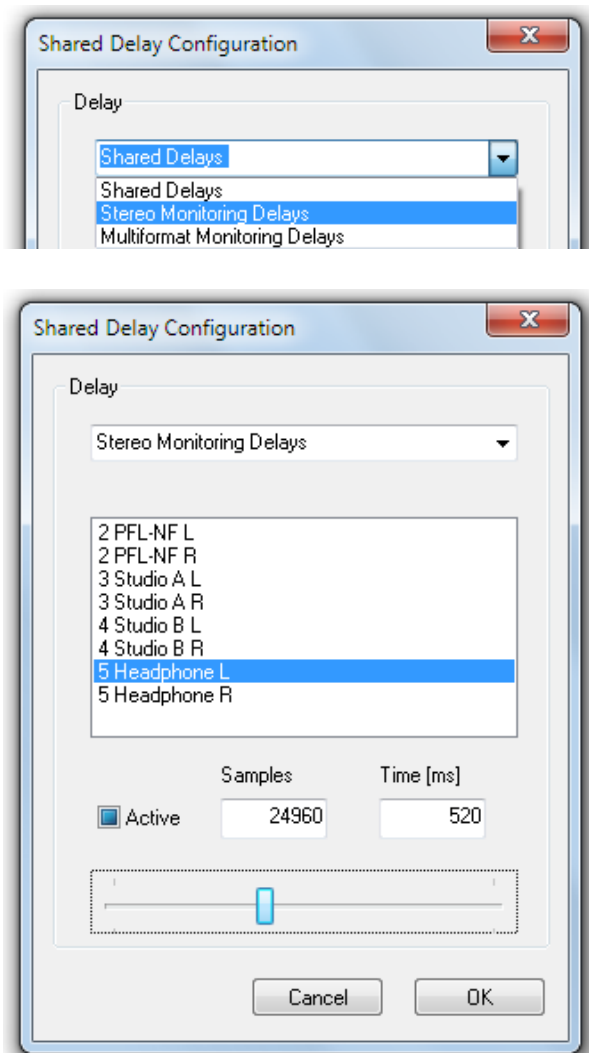

In addition, the shared delays are no more saved in snapshots, but are valid for

the whole title. The monitoring delays, however, remain identical throughout all titles (if desired), they are still saved in the monXxx.ini file.

4.6.1.2.4 VSP Properties

This feature is described in [chapter 3.4.3.6](#).

4.6.1.2.5 TC-Reader/Generator

The TC Reader / Generator page is used for adjusting various settings of the integrated TC reader and generator, such as the time source and frame rate.

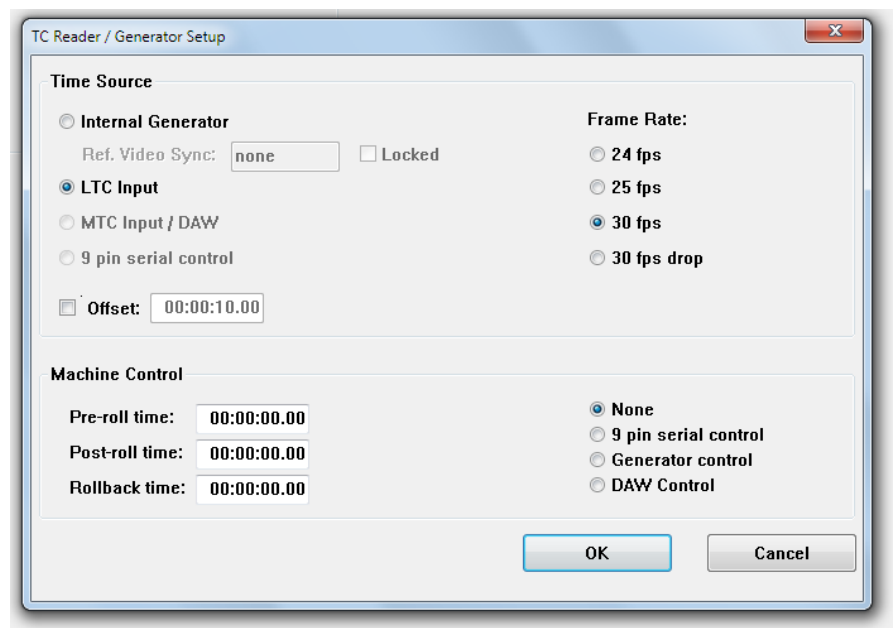

4.6.1.2.6 N-1 Assignment

The N-1/mix-minus Assignment window allows setup and configuration of the N-1/CleanFeed/mix-minus structure.

The principle of N-1 is summing; i.e. all desired channels (N) get summed to a bus except the 'minus one' (-1).

The N-1/mix-minus bus is a special bus that sums the contributions of channels other than the Bus Owner of the Channel, thus performing the N-1 summation. The number of Mono and/or Stereo N-1 busses depends on the currently loaded DSP configuration.

The Bus Owner channel is the channel which:

- Does not contribute to the N-1 bus
- Contains the N-1 bus output level and Talkback controls on the physical channel strip assigned to it
- Has an N-1 indication on the assigned channel strip.

The setup and assignment of the N-1 is done in three steps:

- 1 A Bus Owner (-1 channel) must be assigned to an N-1 bus.
- 2 The N-1 Send Line (Physical Output) and Return Line (Physical Input) must be patched in the General Patch
- 3 The channels which are to be sent to the -1 must be assigned to the bus.

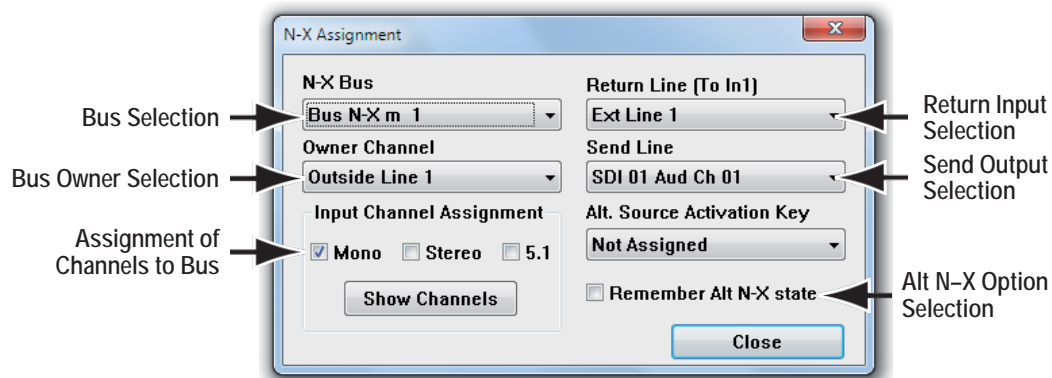

The N-1 Assignment window allows fast setup of this process.

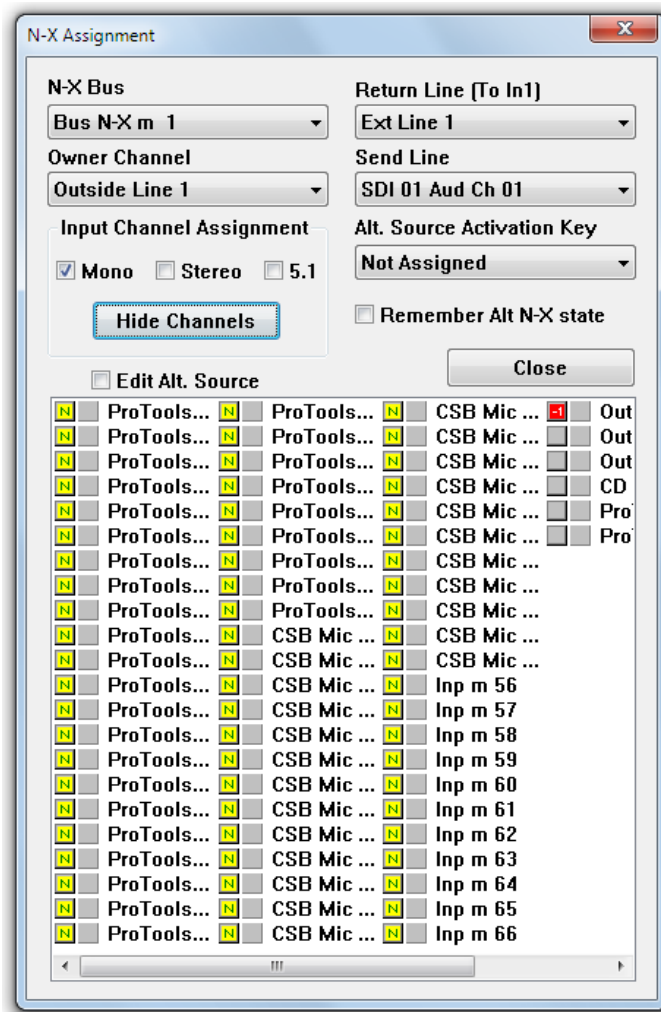

Setup is as follows:

- 1 First choose the N-1 bus to be used with the drop-down menu, and the Bus Owner Channel which will be the -1 channel.
- 2 Use the drop-down menus to select the Return Line (Physical Input) and Send Line (Physical Output) to which the Outside Source (-1) is connected to the console. This is essentially making cross-points in the General Patch without having to go to the General Patch page. Selections made using these drop-down menus will change any previous patching of the Outside Source. *Please note that the label type shown is taken from the General Patch.*
- 3 The three Channel Assignment check boxes allow fast allocation of all Input Channels to the chosen N-1 bus. If only Mono inputs are chosen, then *all* Mono input channels in the system (*except the Bus Owner channel*) are routed to the chosen bus. If specific channels need to be routed instead of *all* Mono, Stereo or 5.1 input channels, the Show Channels button should be clicked. This will extend the window as shown below, to allow individual assignment of the channels to the chosen N-1 bus within the currently loaded DSP configuration.



The chosen Bus Owner channel is shown in the list as  (in our example, Outside Line 1), any assigned channels to the bus are shown in the list as  (e.g. Inp m 56).

Clicking on individual channel boxes will either select or deselect a channel; this makes the N-1 bus in fact being an N-x bus. It is also possible to mark a number of channels to be assigned by left-clicking and dragging across a number of channels for speed.

It is also possible to assign channels to a configured N-1 bus by using the bus assign window on the control surface.

The talkback and N-1 bus level control will be displayed in the assigned channel strip for the N-1 Bus Owner Channel.

 **Tip** The N-1 settings are saved within snapshots.

Option *to bring back ALT N-X status upon closing fader*

Option active (): The signal will switch back to ALT N-X upon *closing* the fader again, in case it was active before opening. This allows e.g. feeding an off-air signal to the outside lines while they are not on air (e.g. output signal from on-air console including commercials).

Result: When the fader is opened, the outside lines get the normal N-X signal; when closed they are switched to the off-air signal.

4.6.1.3 Signaling

The Signaling Setup menu allows on-line assignment of available Signaling relays to functions, such as Red Light activation or Fader Start of remote systems. It also allows Save and Load of such assignment configurations for later use.

Output Signaling is always related to the Patch Sources. The Vista console is fully assignable, meaning that:

- A channel can be assigned to *any* channel strip;
- An audio Source (for example, a CD Player) can be patched into *any* channel and be accessed via *any* fader;
- A snapshot can change the *entire* Patch settings.

For these reasons, it is impossible to assign an output Signaling device, such as a Fader Start relay, to a *specific* fader. Instead, it has to be assigned to the Patch source which, in turn, is assigned to a fader via the Patch. In this way, the system logic is able to activate, for example, the correct relay when a fader is opened. All output Signaling always follows the Sources, and the Signaling Assignment itself also is Source-oriented.

The Vista system automatically knows how many Signaling relays are available by accessing that information from the configuration and *.ini files. The available Sources are read from the Session Configuration. The Signaling Configuration is all about assigning the right relay to the right source, as we will see next.

Editing the Relay Labels

First, the system administrator needs to determine how the relays will be connected to peripheral equipment (machine transport controls, lamps, etc.). Then, the fixed relay labels can be edited to reflect their functions. For this action, select the Edit User Labels button from the Signaling Out or Red Light menu items:

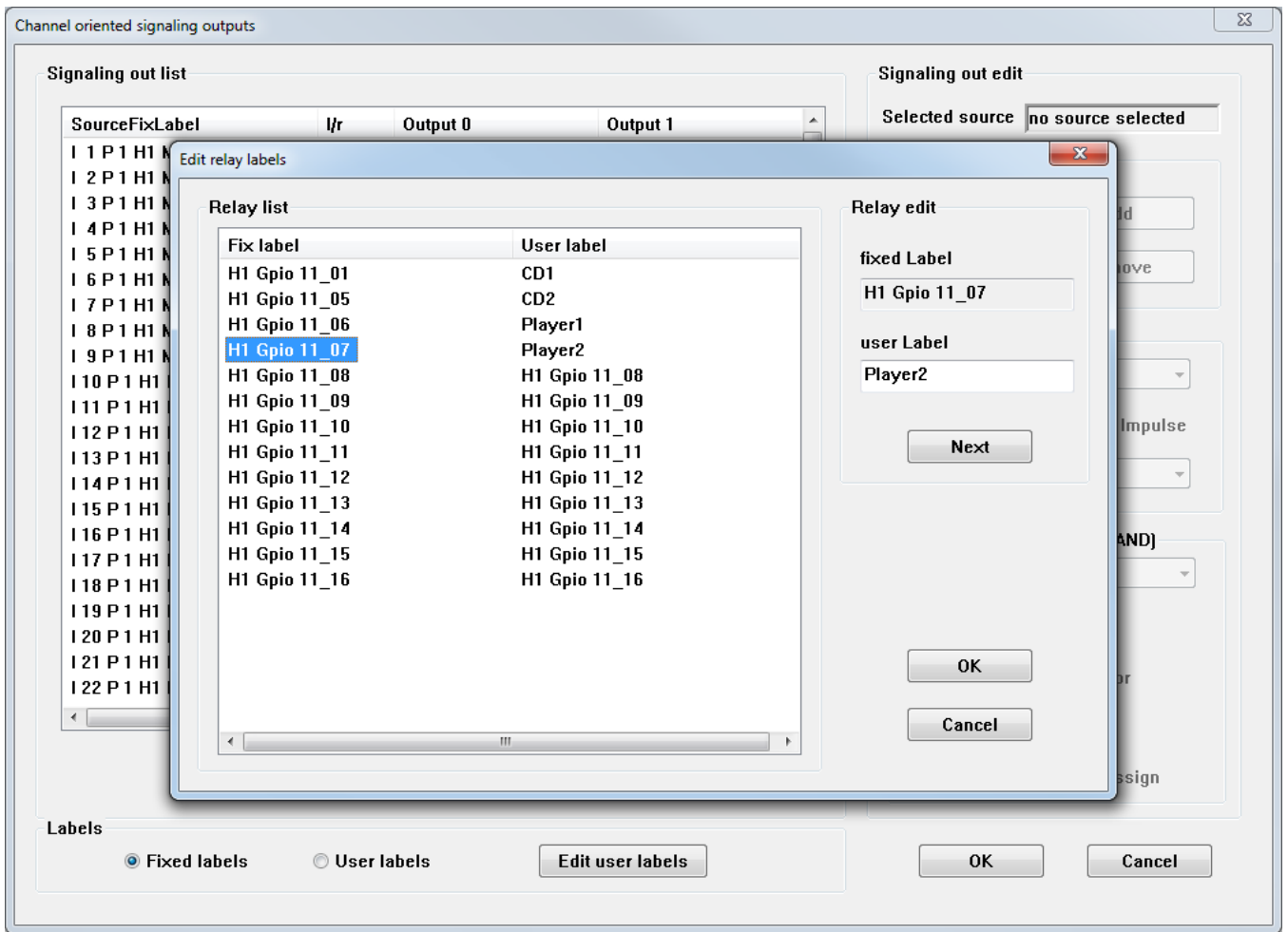

This action will open the Edit relay labels page and first allow selection of the desired relay, and then to enter a user label for each relay. Be sure to click ok when finished; otherwise all changes will be lost.

The fixed relay labels have been automatically generated by the Vista system. They have the format **SIGOUT0_REL01**, where **SIGOUT0**, **SIGOUT1**, etc. define the relay card number, and **REL01**, **REL02**, etc. define the relay number on a particular card.

There are 16 relays per card. Some of the physically present relays may be assigned to internal system functions and may therefore not be available for the Signaling Configuration.

Source labels can be edited in the Patch pages; refer to [chapters 4.4.2 and 4.4.3](#).

Signal Out Configuration

Signaling Outputs are generally relay contacts installed in the monitoring frame. They may be used for various purposes, such as:

- Fader Start
- Microphone ON actions (loudspeaker muting, etc)
- Parallel Record/Ready mode of DAW tracks.

Up to four different relays may be configured for each source. They may feature different Trigger Setups (see later). For each relay, Latching or Impulse

operation modes can be selected.

Multiple sources can be configured to one single relay, forming a logical OR combination.

There are four steps in the Signaling Configuration:

1. To configure the Signaling, first select a source in the Signaling Out List,
2. Within the Signaling Out Edit window, select the desired output 0 to 3. In most cases the correct Output (the next one that is unassigned) will be selected automatically. Now you can add or remove a relay to/from this source.

Click to Remove all Assigned Relays

Up to 4 Relays can be Selected per Source

Select which of 4 Outputs

Set User-Defined Triggers

3. Now you need to select the desired relay (use the arrow button to open a list of relays), and to determine its mode of operation to either latching (contact closed when trigger conditions are fulfilled) or impulse (contact closed for a short time when trigger conditions are fulfilled, and then opened again). Impulse mode closure time can be set to 100 or 200 ms.

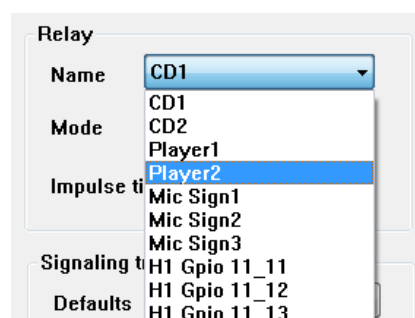

4. The Triggers have to be set according to the application of the selected relay. All Triggers always work in a logical AND fashion:

- The desired Source must be patched to the appropriate Channel (implicitly understood and done in the Patch), and

There is the possibility to check up to five other Triggers to finally trigger the relay:

- User key 1, *and*
- User key 2, *and*
- Input Selector, *and*
- Channel On (MUTE), *and*
- Fader open.

Any combination of the five possibilities above can be used. It is also possible to select from a default list of pre-configured Trigger combinations:

- Fader start, *or*
- User Defined.



Typical fader start setup for two stereo sources (I77/I78 and I79/I80):

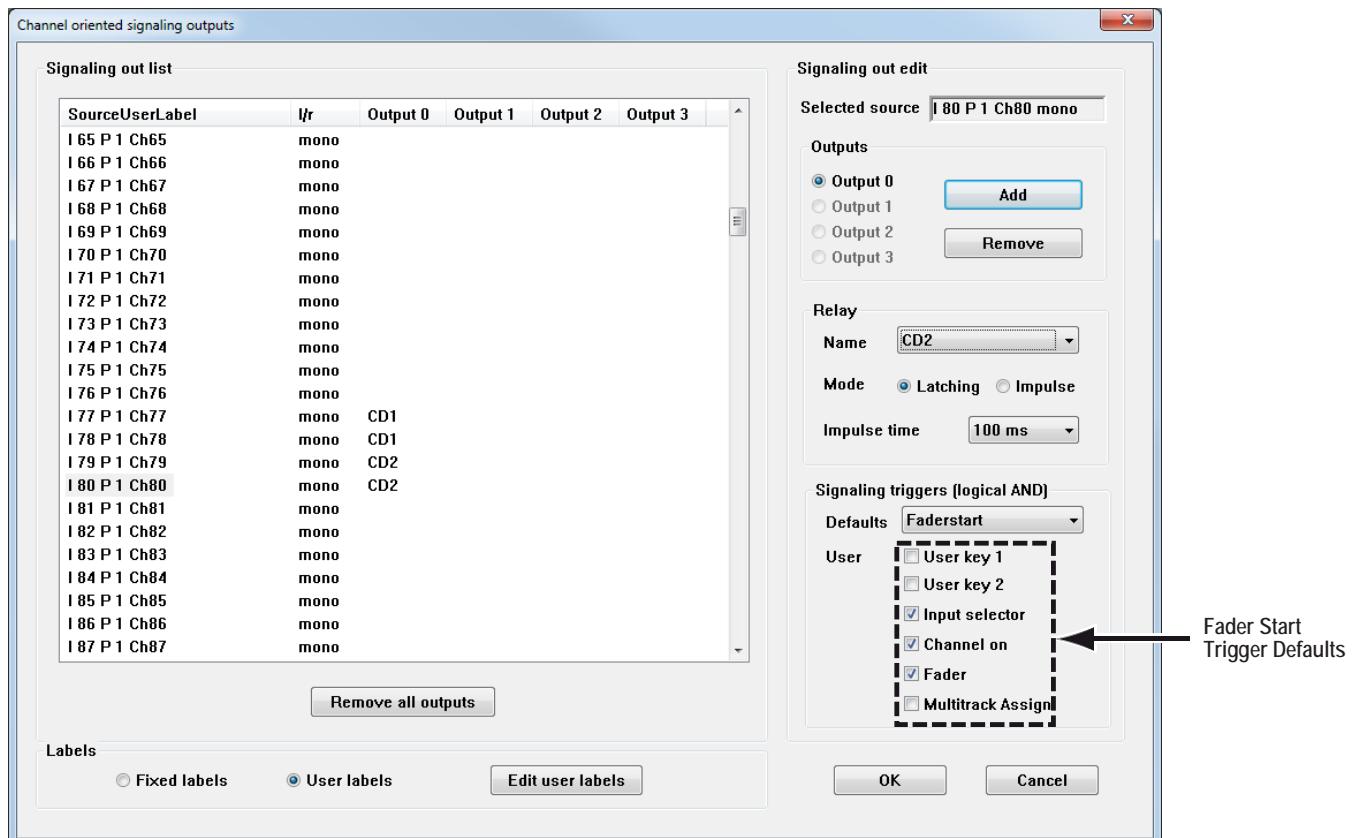

The typical Fader Start Trigger combination is:

- Input selector, *and*
- Channel on (MUTE), *and*
- Fader (open).

You can also remove all assigned relays from the list by clicking on the Remove all outputs button.

- ☞ **Tip** For a typical stereo source, such as a CD player, the same relay should be configured for both the left and the right signal part, as shown in the example above for I77/I78 (relay *cd1*) and I79/I80 (relay *cd2*). This action ensures that the CD player will start even if it is connected to two Mono Input Channels, and only *one* of the faders is opened.

Red Light Configuration

Generally, Red Light Outputs are relays installed within the monitoring frame. Only one relay is normally used for the global Red Light Signaling, but several relays can be configured independently if more than one Studio exists.

The Trigger conditions for a Red Light relay to be activated are fixed to the following:

- A Source configured for Red Light is patched to a Channel, *and*
- The Input Channel Input Selector is set to the above Source, *and*
- The Input Channel Fader is open, *and*
- The Input Channel ON (MUTE) is open, *and*
- The Input Channel is routed to at least one Master Bus, *and*
- The Master Channel Input Selector is set to the above Source, *and*
- The Master Channel Fader is open, *and*
- The Master Channel ON (MUTE) is open.

In other words, the audio signal has a fully open path from the Source to the Master Channel output. If an Input Channel is routed to a group only, then the Group has to be routed to a Master, etc., to fulfill the Trigger conditions. Multiple sources are usually configured to one single relay – they form a logical OR. For instance, all Mic Inputs from the same room would be configured to the same Red Light relay.

There are four steps in the Red Light Configuration:

1. To configure the Red Light, first select a source in the Red Light List;
2. You can then add or remove a relay to/from this source in the Red Light Edit window.

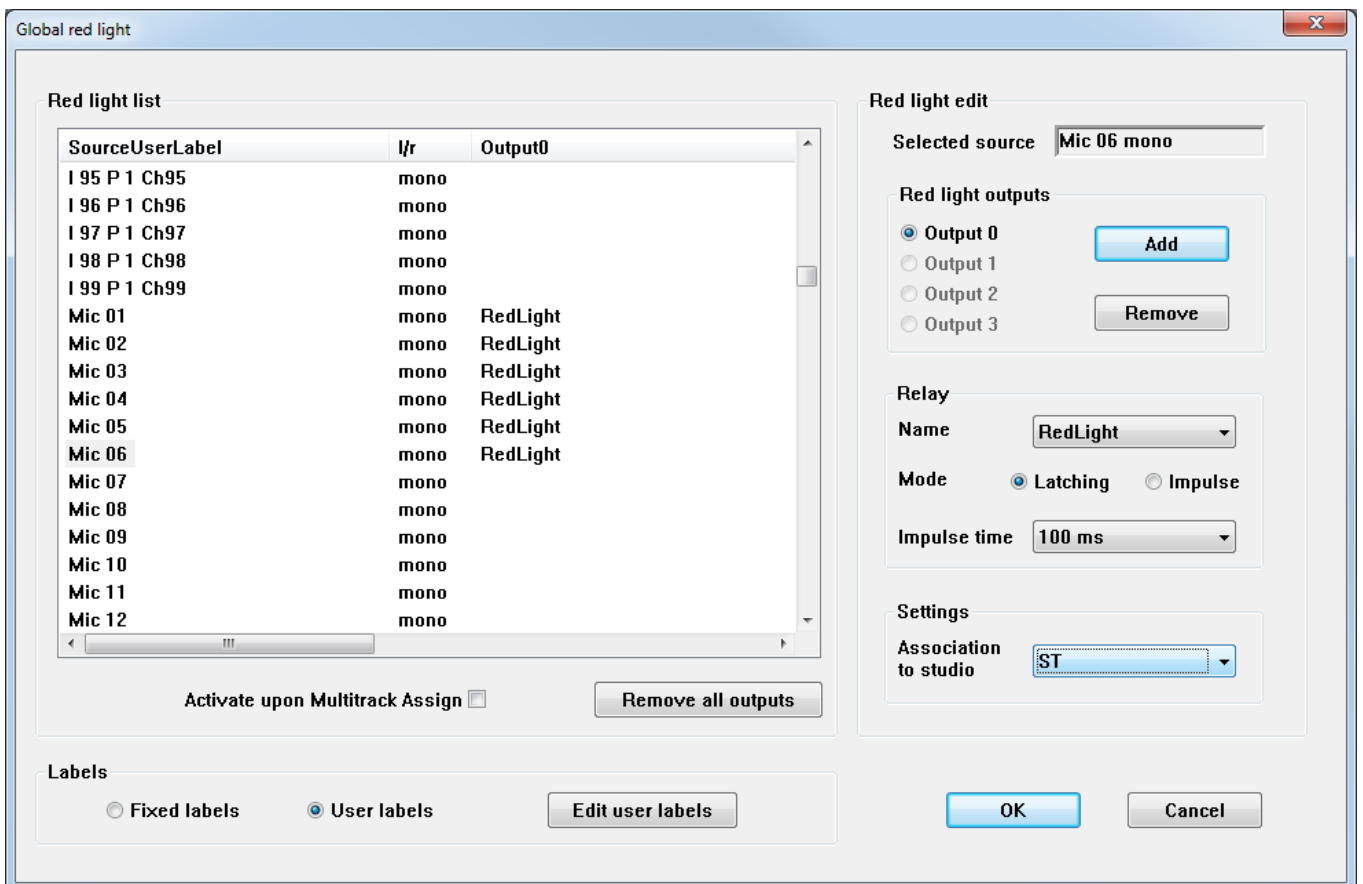

- Now you have to select the relay itself (use the arrow button to open a list of relays), and to determine its mode of operation to either latching (contact closed when trigger conditions is fulfilled) or impulse (contact closed for a short time when trigger conditions is fulfilled, and then opened again). Impulse mode closure time can be set to 100 or 200 ms. Obviously, the actual relay that is externally wired for Red Light must be selected.
- In the Settings window, an association to a Studio can be set. Usually, only one Studio is being used. If, however, more than one Studio should be present, each may require its own Red Light relay and its configured Sources. In this case, several relays can be configured independently. To select a Studio, click on the arrow button, and select a studio from the list. If a Studio is associated, the Red Light will also be shown on the Desk's Studio monitor Unit.

You can also remove all assigned relays from the list, by clicking on the Remove all outputs button.

4.6.1.3.1 Load Signaling Configuration

This action opens a window that allows selection from existing Signaling Configurations to load into the Vista. The `c:\D950SYSTEMDB` directory will usually be displayed first, and a Session Configuration must be selected. The Signaling Configuration files have a `*.sig` extension. This process will load all saved relay assignments for both the Signaling Out and the Red Light Configurations, and the relay user labels.

4.6.1.3.2 Save Signaling Configuration As

This action opens a window that allows entry of a new name for the Signaling Configurations to be saved. The `C:\D950SYSTEMDB` directory will usually be displayed first, and a Session Configuration must be selected. The Signaling Configuration files have a `*.sig` extension. This process will save all relay assignments for both the Signaling Out and the Red Light Configurations, and the relay user labels. Any number of such Configurations can be saved and loaded at a later date.

Note: Each title contains at least one `*.sig` file that holds the signaling settings of the time when the title was closed or saved manually.

4.6.1.4 CGM

4.6.1.4.1 Control Group Basics

Control Group Master

A Control Group is a group of console channels controlled by a Control Group Master (CGM), similarly to the VCA groups in analog consoles.

The Control Group Master is a dedicated channel of a special type. The sole purpose of the Control Group Master is to control the audio functions of its Members.

Up to 32 Control Group Master channels can be defined by the currently loaded configuration. The number of each Control Group Master is shown on the 7-segment display in the channel strip of each CGM, following the rule:

| Control Group No. | Display |
|-------------------|---------|
| 1 | 0 |
| 2 | 1 |
| ... | ... |
| 10 | 9 |
| 11 | A |
| 12 | b |
| 13 | C |
| 14 | d |
| 15 | E |
| 16 | F |
| 17 | 0. |
| 18 | 1. |
| ... | ... |
| 26 | 9. |
| 27 | A. |
| 28 | b. |
| 29 | C. |
| 30 | d. |
| 31 | E. |
| 32 | F. |

The Control Group Master channel controls the audio functions of the Members. Master channels can be assigned to desk strips in the same way as any other console channel. The desk strip to which a Control Group Master is assigned will display the following:

- Control Group Master numbers in the seven-segment display next to the fader: 0 through 9, characters A through F (and, for numbers above 16, the same but followed by a decimal point, as shown in the table above);
- The fixed label is set to CGM (Control Group Master), but can be set to display user labels such as DRUM, LVOX, BVOX, RTHM, etc. in the Control Group Filter dialog box in the GC.

Control Group Members

Control Group Members can be selected to and deselected from a Control Group during the console operation. This is done in a special Control Group Edit mode. Any console channel can be selected as a member in a Control Group. The members can be 'stolen' from one Control Group to another. When a channel is selected as a member in a Control Group, its channel strip displays the Control Group in the seven-segment display next to the fader in the same manner as described above.

Operating an audio parameter on the Control Group Master influences that parameter on all members (if that parameter has been selected in the Control Group Filter Dialog Box during Control Group Edit mode). It offsets the member value by the move amount of the Master. Operating the parameter on the member influences only that member's parameter.

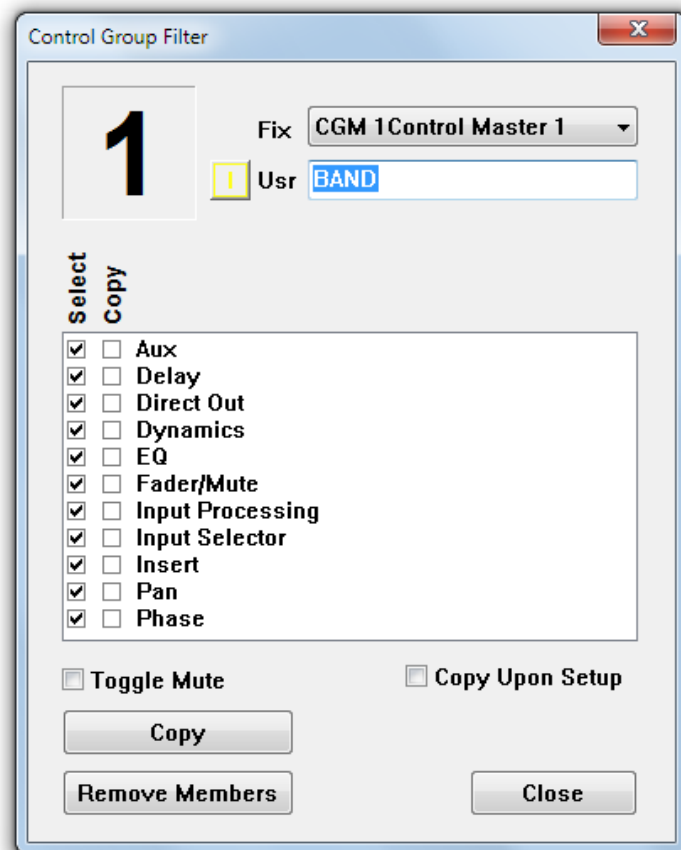

4.6.1.4.2 Control Group Setup

The Control Groups are edited in the Control Group Setup Mode. This mode is activated through the **SETUP: GROUPS** key.



On first press, the **SETUP: GROUPS** key is lit to show that an activity has been started but not yet finished. All **LINK/SEL** keys of Control Group Master channels are half-lit. Pressing one of these enables setting up the corresponding Control Group. The **LINK/SEL** keys of the Control Group members are lit, the ones of non-members are half-lit. The graphical controller automatically activates the Control Group Filter dialog (see above) for the selected Control Group.

When a Control Group is selected for editing, member channels can be added or removed from the Control Group by using their **LINK/SEL** keys. If the **MULTI SEL** key is deactivated, all members are cleared upon pressing any **LINK/SEL** key, similar to creating a gang. During editing, the Control Group is not active, i.e. the setting of the Control Group Master can be changed without influencing the members. This can be used to adjust the offset between the Master and the Members if required.

Editing a control group can be terminated either by pressing the **LINK/SEL** key of the master, or by exiting setup mode by pressing the **SETUP: GROUPS** key in the control bay. If you now want to proceed with editing of another control group, first deselect (using the **LINK/SEL** key) the Control Group Master you have just finished with, and then select the new one that you wish to edit.

4.6.1.4.3 Control Group Filter

When Control Group Editing is activated, the graphical controller automatically activates the Control Group Filter dialog box for the selected Control Group (see screenshot on the previous page).

In the Control Group Filter dialog, the user can define functions to be grouped or not. To group the desired function, the appropriate **Select** checkbox must be checked. If **Select** is unchecked, the functions' control can be moved freely without influencing the members. Normally, when the members are grouped, their local values of **Fader/Mute** are left untouched when the group is formed – they are grouped in a relative way. If absolute grouping is desired, values can be copied from the master to the members:

- By checking the **Copy Enable** checkbox and clicking on **Copy**;
- By completing the editing of a group while the **Copy Upon Setup** checkbox is checked.

There is also a context menu available, called up by right-clicking within the edit dialog:

- If the cursor is placed over the **Select** items, the menu allows to check or clear all select boxes;
- If the cursor is placed over the **Copy** column, the menu allows to check

and clear all copy parameters;

- and if it is placed over a white space, it does both.

Note: The Control Group Filter dialog box can also be started by clicking on the Control Group Filter item on the Options menu of the graphical controller. Clicking on the Close button does *not* terminate the Desk editing mode.

Absolute/Relative Faders are implicitly controlled in a relative way. This means that all the members will remain in relative positions to each other when the Master Fader (or other control) is moved. The member Faders can be forced to match the Master Fader using the Copy function in the Control Group Filter dialog, see above.

Muting can be controlled in absolute and relative mode. The relative (Toggle) mode for the Mutes can be selected by the user in the Group Filter dialog. If selected, the Mutes can be set to On or Off on the members and will be toggled when the Master Mute is used. If Toggle is not selected, all Mutes on the members will be forced to the same status as the Master Mute the next time the Master Mute is used, regardless of their original status.

Member Behavior When a new member is added to a Control Group, it keeps its values until a change is made in the Control Group Master. At that moment, the change is transferred to all members. When a member is separated from a Control Group it keeps its current setting which includes the Master offset(s) that have been applied along the way. Member values can be changed locally at any time, without affecting the status of the other members or of the Control Group Master.

Over-Range All controls can have an over-range. The over-range condition can occur if the Member Fader has reached its top or bottom position while the Master Fader is still moving. During over-range, the relative levels of the members are kept intact, even if the Fader (and the audio level) can not move anymore. Over-range can be positive or negative. The maximum value of over-range can be twice the normal working range of the Fader (100 dB) in both up and down directions.

The over-range of a Member can be zeroed easily. Simply move the Fader of a Member in over-range by a bit, and the over-range will be zeroed.

Note: This will, however, clear the initial relative level of that particular Member with respect to the other Members.

Snapshots Control Groups are part of the snapshot. Their data comprise three parts:

- Members of a Control Group (which channels are Members in a Control Group);
- Control Group settings (filter and Copy settings);
- Parameter values of the Control Group Masters.

4.6.1.4.4 Control Group Assignment

A Control Group Assignment dialog window can be started from the SysAdmin (system administration) menu in the graphical controller. This window allows to view the members for a selected Control Group and to edit the members by clicking or dragging them graphically on the screen. Selection of the control group to be edited is not synchronized with the Desk selection – so two different control groups can be viewed at a time.

The Control Group Assignment window serves a similar function as the

SETUP: GROUPS key on the control surface, except assignments are made via software, and the Control Group Filter window does not open.

To assign a channel to a Control Group, select a Control Group Master using the pop-up menu in the field at the top of the window. Channels can be assigned or de-assigned by double-clicking the channel's name. Keep in mind that a channel can belong to only one Control Group at a time. If assigned, a yellow N will appear in the box to the left of the channel name, and the number of the Control Group will be displayed in the channel's fader. Control Group Assignments are saved within snapshots and presets.

4.6.1.4.5 Hierarchical CGMs

It is possible to have control group masters (CGMs) being a member of other CGMs. The indication of the control group number on master channels has therefore slightly changed: The green display next to the fader is constantly showing to which master a channel belongs. If there is no further hierarchical level above a CGM, this area is dark. The number of the CGM itself can be seen in the second line of the label display area.

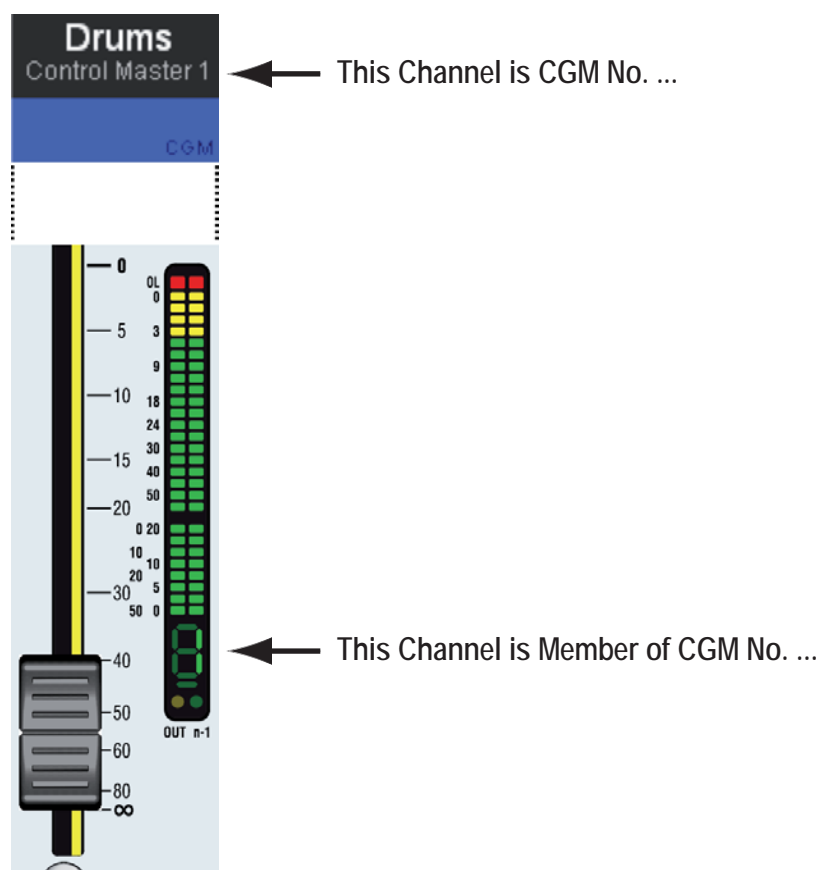

4.6.2 The Settings Ribbon Tab

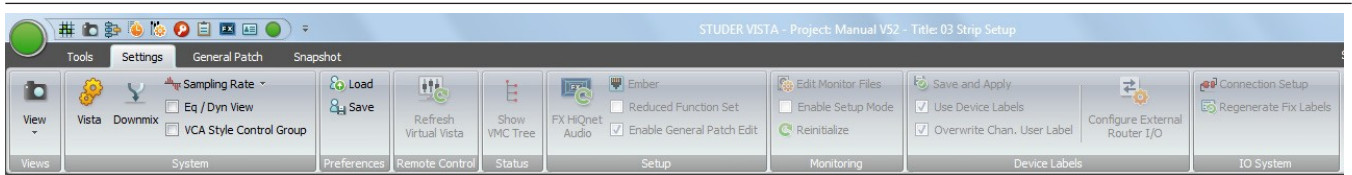

The Settings Ribbon Tab is divided into two categories :

- **System** (System settings)
- **Preferences** (Preferences can be saved and loaded)

.. as well as another six categories which can only be accessed when logged-in as System Administrator :

- **Remote Control**
- **Status**
- **Setup**
- **Monitoring**
- **Device Labels**
- **I/O System**

These six categories are explained in [chapter 4.7](#)

4.6.2.1 System

4.6.2.1.1 Vista Settings

The Vista Settings window allows different adjustments, most of them self-explanatory; there are six tabs for selection of Desk (timeout and delay time settings), Console Lighting, Machine Control, Speaker Calibration, Misc(ellaneous), and View settings.

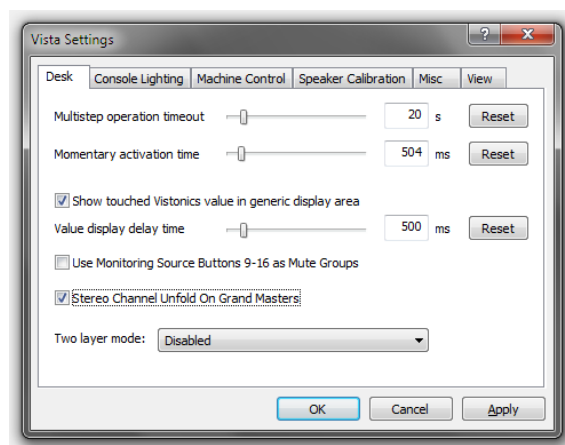

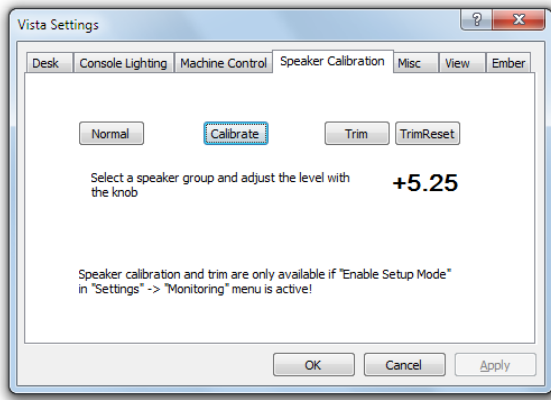
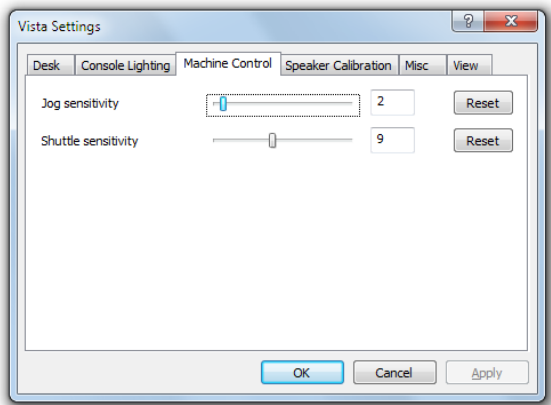
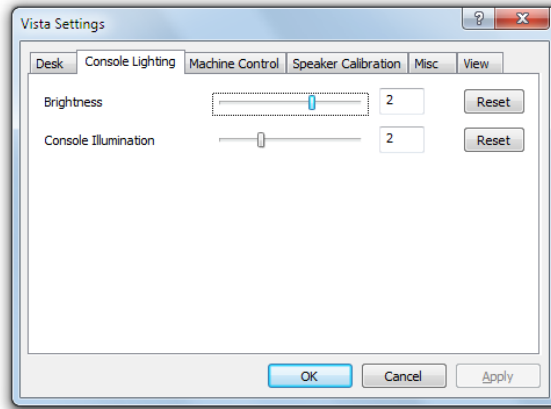

Speaker Calibration

Calibrate Mode

Trim Mode

To allow access to the speaker calibration, the Enable Setup function must be enabled. Please refer to [chapter 4.7.8](#).

Calibrate mode allows setting a level offset for a whole monitor group (**MAIN**, **ALT** or **NEARFIELD**) relative to the other two. To activate this mode, click the ‘Calibrate’ button and select a monitor group on the control surface monitoring section. The offset range is from –20 dB to +10 dB. The current calibration offset will be displayed in the display box. The calibration offset can be changed in steps of ¼ dB.

Trim mode allows setting an offset for a single loudspeaker relative to others in a group. The offset range is ±10 dB. Trim mode is selected by clicking the ‘Trim’ button. Select the monitor group (**MAIN**, **ALT** or **NEARFIELD**) and **SOLO** the speaker to be offset on the on the control surface monitoring section. The current Trim value of the selected speaker will be displayed in the window. The Trim offset can be changed in steps of ¼ dB. To clear all Trim offsets within the selected monitor group, click the ‘TrimReset’ button.

Misc (-cellaneous Settings)

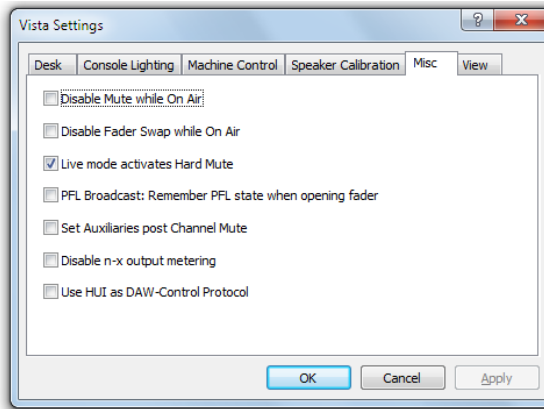

- The MUTE key may be disabled whenever the console is in ‘On Air’ (live) mode.
- The state of sending the alternate n-x signal instead of the regular one may be restored after opening and closing the fader.
- If the broadcast PFL mode (also referred to as ‘PFL cut on channel active’ function) is enabled, audio signals are cut from the PFL bus if the channel is ON and the fader is open; the channel will also go back into PFL state when the fader is closed again.
- If ‘Set Auxiliaries post Channel Mute’ is selected, all auxiliary busses are muted if the channel MUTE key is activated. If this option is not active (default), only the auxiliary busses switched to post-fader are muted upon channel mute.
- The n-x signal output metering may be disabled.
- For controlling a DAW, either the Mackie HUI protocol or the Mackie Control Protocol can be selected. If ticked here, HUI is active.

(Graphic EQ) View

When the 30-band graphic EQ is switched to the faders of a 32-fader console, all faders except the two control bay master faders are used anyway. For 42-fader consoles however, it can be defined here in which fader bay the leftmost EQ band is represented.

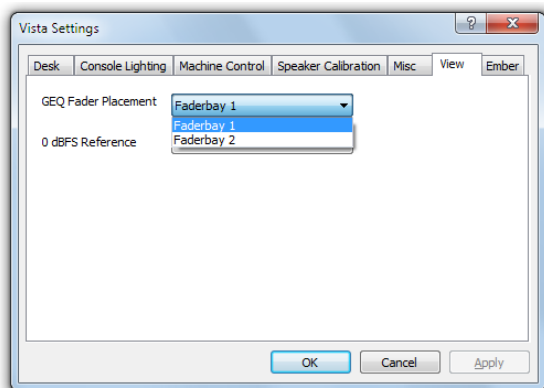

(0dBFS Reference) View

The 0dBFS Reference setting adapts the readout of the Mic Gain dB value to the systems analog reference level.

The analog reference level is given through the calibration of the systems analog D21m Line Input- and Line Output cards. On these D21m cards, the level is calibrated with DIP switches and potentiometers.

The systems analog reference level is calibrated to the customers specification when a system is ordered.

Important : The 0dBFS Reference setting influences only the readout of the Mic Gain dB value. No levels are changed by changing this setting !

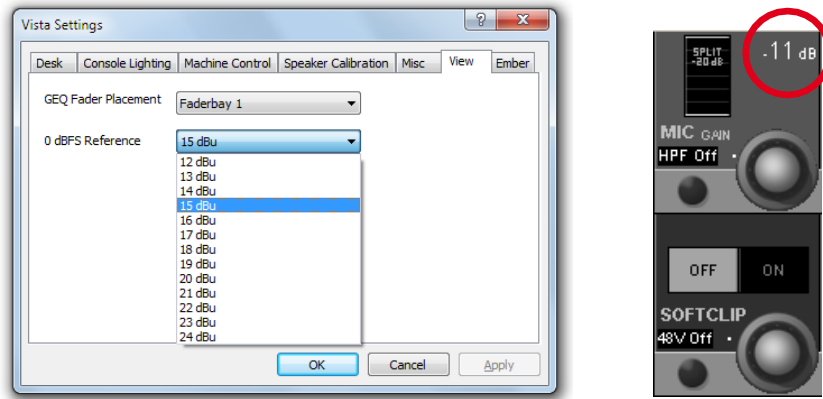

4.6.2.1.2 Downmix Settings

This item allows defining the way in which surround channels are downmixed to stereo outputs as well as their level contributions.

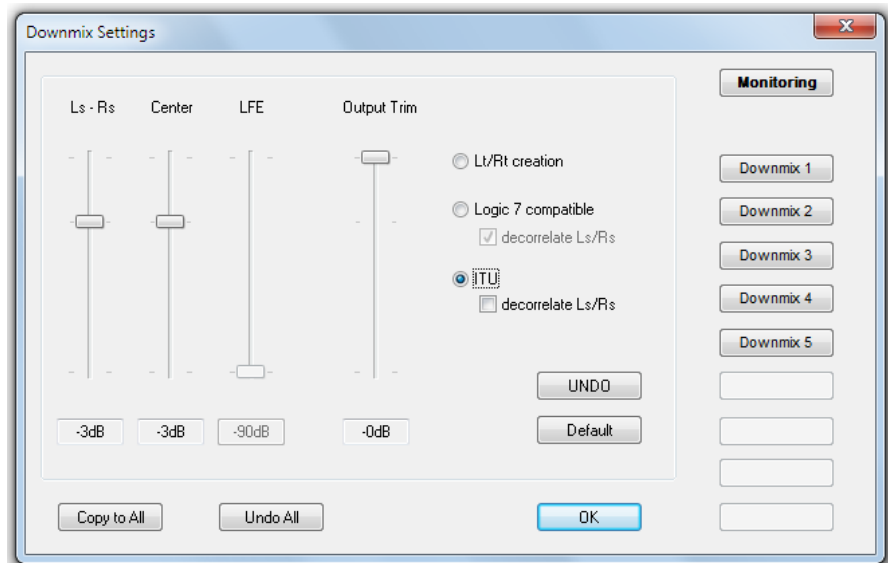

4.6.2.1.3 Sampling Rate

This item allows selecting the audio sampling rate from 44.1, 48 (default), 88.2 and 96 kHz.

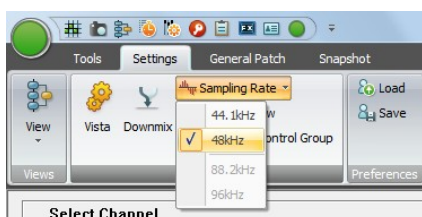

4.6.2.1.4 EQ/Dyn View

The EQ/Dynamics View option can be checked or unchecked. If *checked*, the graphical controller will display an EQ and/or a Dynamics screen.

EQ Screen The EQ screen is displayed for the channel on which any of the rotary encoders is touched or operated while the channel's controls are in the EQ/Filter page. Please note that the EQ screen will appear when any EQ/Filter control is touched. However, for the EQ screen to be displayed, *EQ/Filter must be engaged* in the channel.

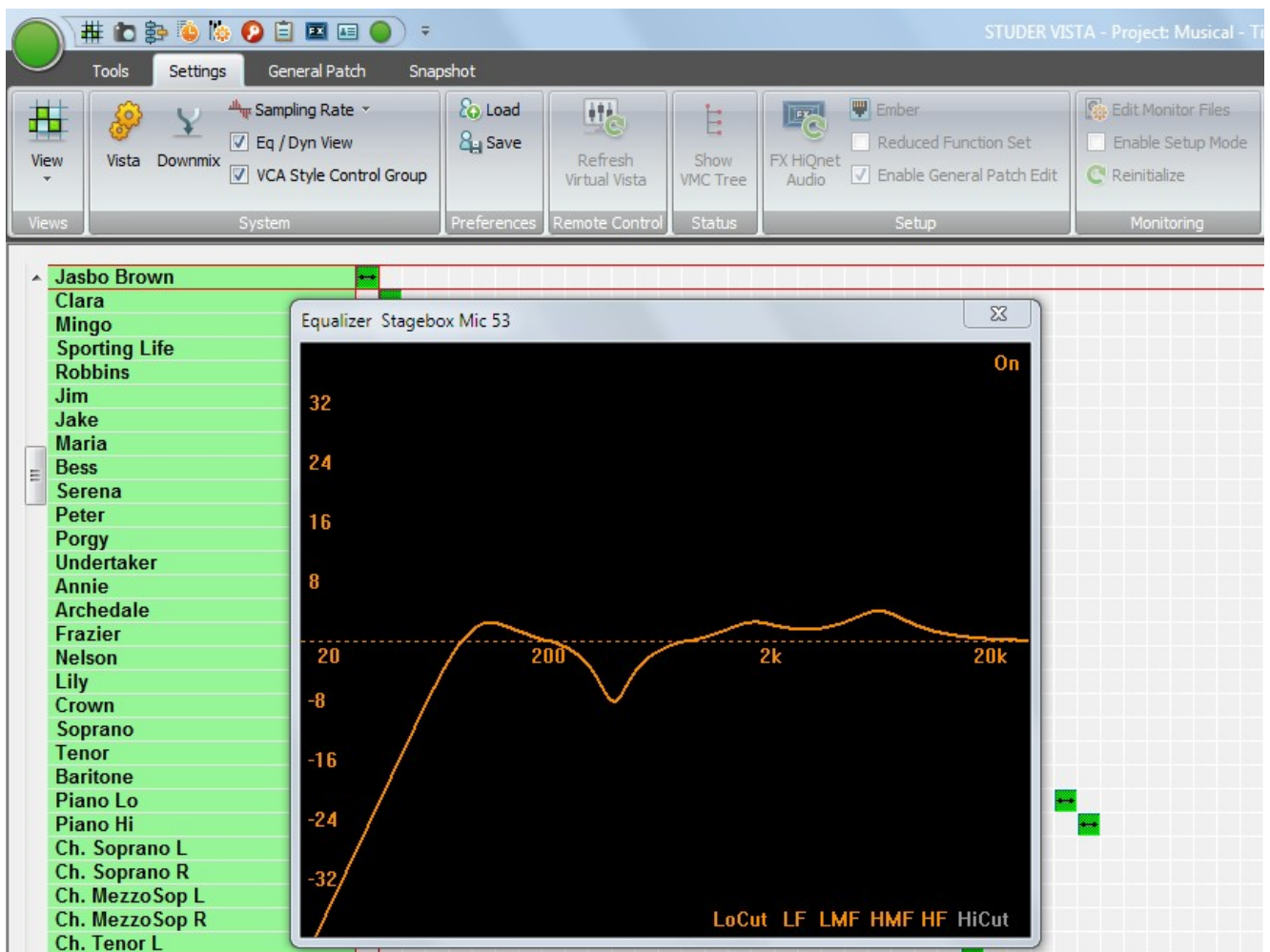

The EQ screen is time-limited and will automatically disappear several seconds after the last touch, or when pressing ESC. It is always on top of any other screens/pages.

Dynamics Screen The Dynamics screen will appear when any Dynamics control is touched. However, for the Dynamics screen to be displayed, *at least one of the LIM, COMP, EXP, or GATE functions must be engaged in the channel.*

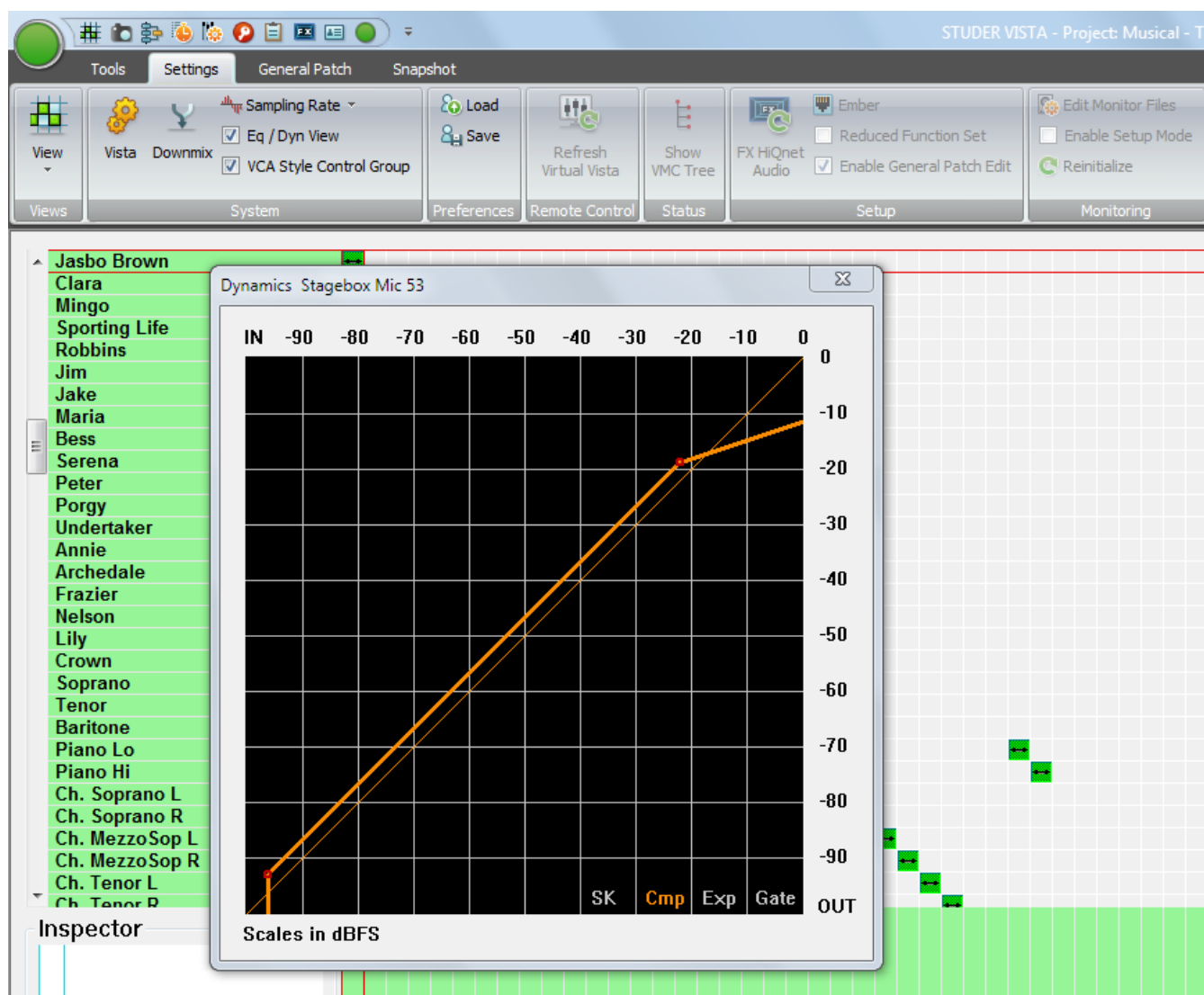

The dynamics screen is time-limited and will automatically disappear several seconds after the last touch, or when pressing ESC. It is always on top of any other screens/pages.

4.6.2.1.5 VCA Style Control Groups ('Motors Off')

The 'Control Group Masters' in a classic sense were implemented in such a way that all channel faders belonging to a certain control group would automatically move whenever the master fader was moved. This has the advantage that you always visually see the audio settings currently active in the DSP core. However, there are two drawbacks to this behavior:

When the Control Group Master fader is closed, the user cannot adjust the balance between the member channels, since they are moved down together with the master fader.

When the master fader is closed, it is still possible that there is some audio

passing through some of the member channels, since their fader is not completely closed.

With software release 3.4, there is now an alternative way of how the control group master channels can work, that is very similar to the VCA groups of an analog mixing console. Sometimes, this new behavior is also called ‘motors off’. In this mode, the value set on the control group master channels (as seen on their scale) is added to or subtracted from all member channels, and the resulting (audio) level is set in the DSP core. The faders of the member channels don’t move up/down, and so it is possible to have the master fader closed but still to correct the balance between the member faders. In addition, the user can be sure that whenever the master channel is closed, no audio can be heard from the member channels. Since the fader of a member channel doesn’t represent the real audio value anymore, the digits below the label display are indicating the *real* audio value.

Notes If ‘VCA style’ operation is active, you may see member channels change their fader values as soon as they are added to a control group. This is the case if the master channel is already set to a value different from 0 dB at the moment when a new slave channel is added to the group. This behavior is by intention, in order not to have any audio changing when adding or subtracting member channels from a control group. Example: You have set a microphone channel to –15 dB, and you add it to a ‘VCA’ group the master channel of which is already set to –10 dB. In the moment the microphone channel is added to that group, the user will see the microphone fader jump up to –5 dB. This results in no audio change, as requested.

The **VCA style Control Groups** option can be found in the Option menu of the graphical controller screen.

4.6.2.2 Preferences

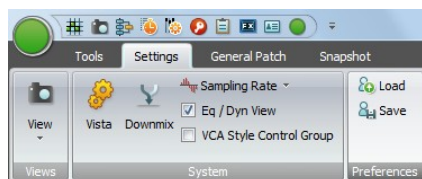

The User menu allows the users to individually save various preferences including page layout, size, and position of various windows.

4.6.2.2.1 Load

This action opens a dialog box that allows selection of a User Preference file for loading. The dialog box will usually display the `c:\D950SYSTEMDB` directory with all the available Session Configurations.

Enter the desired Session Configuration directory, and select the Preference file to open. Click Open or double-click on the file to load.

4.6.2.2.2 Save

This action opens a dialog box that allows selection of a name for a new Preference file, and to create a new Preference file. You can freely create any number of Preferences. The dialog box will usually display the `c:\D950SYSTEMDB` directory with all the available Session Configurations. The User Preference files are best saved together with the current Session Configuration in the Session Configuration directory, because they will probably change only when the users change, and not with every production/title.

Enter a name for the new Preference file, or select an existing Preference file to be overwritten, and then click Save to finish.

The User Preference files have the extension `*.pfc`, which is added automatically; you do not have to type it.

Tip If you should have forgotten to save your preferences, don't worry. The system will save the last-used screen layout at shutdown. When you restart the system, the screen will come up as you left it.

4.7 Fourth Level: SysAdmin functions

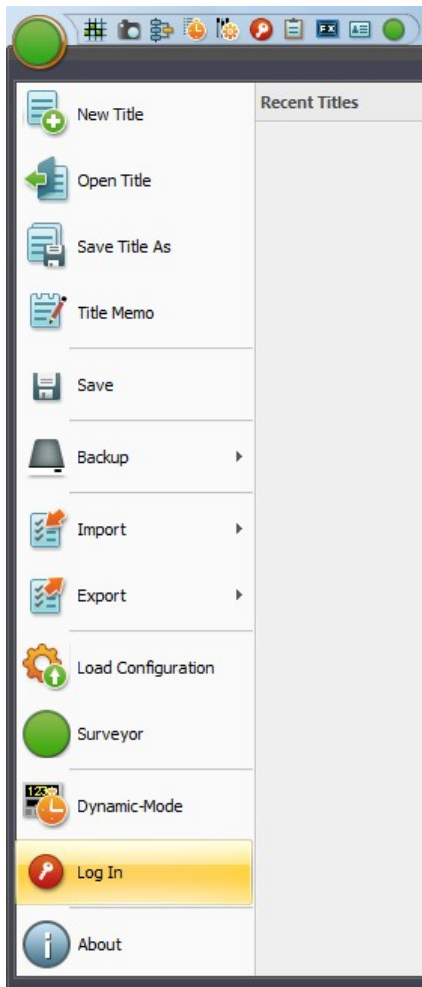

The SysAdmin (system administration) menu items are normally greyed out within the Console's standard operating mode, because they are functions that are only useful during building the console and setting it up for operation. The SysAdmin menu items include various test and configuration possibilities that are not required during normal operation.

Nevertheless, some of the SysAdmin functions will be explained here, since they may be useful if the console is radically reconfigured, the monitoring or signaling systems are expanded, or some detailed troubleshooting is required.

Activating SysAdmin Mode from Standard Mode:

Click on the Log In icon in the Application menu. You will be asked to enter the system administration Password. After completing that, all greyed out SysAdmin menu items become accessible.

Once logged in, the Log In menu item automatically becomes the Log Out function, which allows to leave the System Administrator mode again.

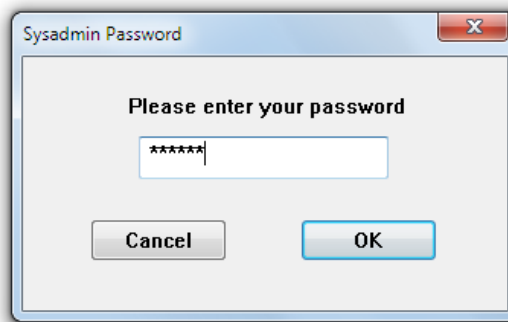

Here is an overview of all SysAdmin menu items, distributed over the four main Ribbon Tabs (Tools, Settings, General Patch and Snapshot) :

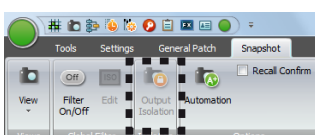
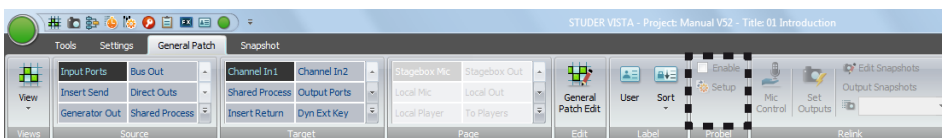
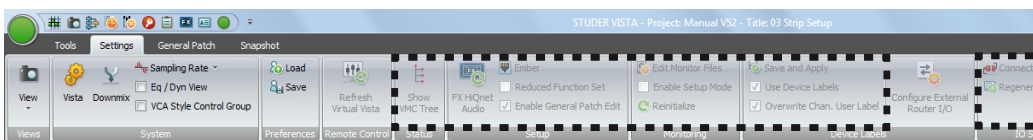
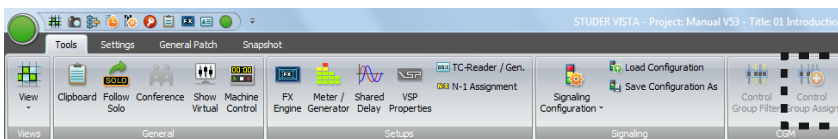

4.7.1 Tools: Control Group Assign

There is a CGM setup window which allows the setup of Control Groups without using the desk operating elements.

It is probably the fastest way to use the desk operating elements for CGM setup, as described in [chapter 2.6.9.1](#).

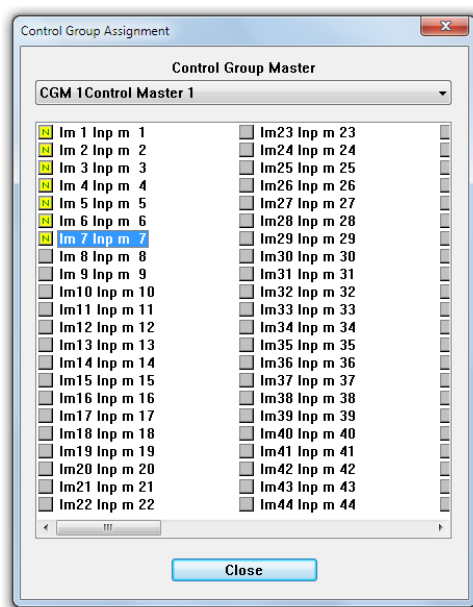

4.7.2 Settings: Show VMC Tree

This feature is primarily used in troubleshooting and typically is not used in normal operation.

Show VMC Tree: This action will bring up the VMC tree View. This page will display a list of all channels, inputs, outputs, busses, and other system elements that are defined within the currently loaded configuration. Double-clicking on one of these items will display the contents of that item's branch. Opening of subsequent branches will take further and further inside the VMC tree. If the item has a changeable parameter, such as EQ high frequency, that parameter may be controlled directly from the VMC tree.

4.7.3 Settings: FX HiQnet Audio

This button is used for the setup procedure if VistaFX are used with the system. Please refer to [chapter 9](#). for VistaFX and the setup process.

4.7.4 Settings: Ember Control

Ember is a control protocol implementation which allows certain console settings to be controlled over TCP/IP.

Ember control provides seamless integration of Vista consoles with 3rd-party broadcast or newsroom automation systems, such as those from Grass Valley, Ross, Sony and Mosart.

Ember connectivity allows the external equipment to transfer signal labels,

and to control input channel levels, solo, mutes, plus Aux send levels and mutes, along with N–X (mix-minus) bus levels and mutes. Master channel levels and mutes can also be addressed, along with Group and Aux master channels. In addition to the control of the mentioned parameters, also console snapshots can be stored and recalled.

Since Ember supports multiconnection setups, it is well suited for installations requiring redundancy concepts.

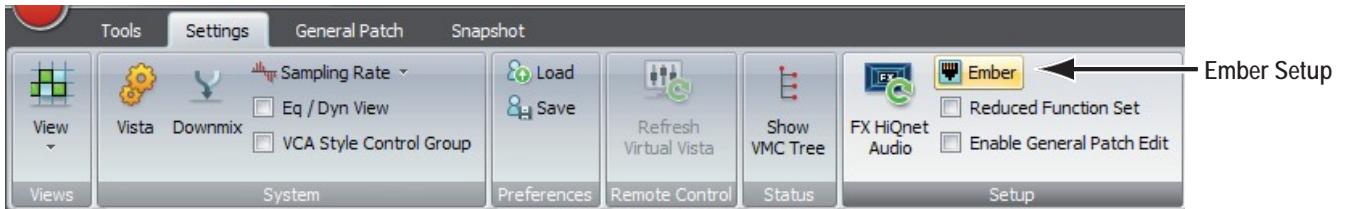

On the **Settings** ribbon tab, the Ember setup window can be opened.

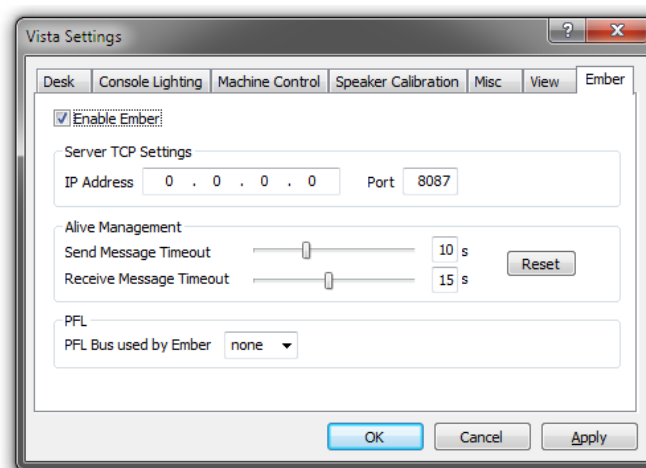

Enter the IP address of the port on the Vista desk PC that you wish to use to connect to the Ember client (automation system). Enter the port, 8087 is default. It is useful to allocate an additional PFL bus for use with Ember to avoid conflict with the desk PFL bus, should both be in use at the same time. It may be necessary to add an additional PFL bus to the DSPconfig, use the config tool in the usual way. Set the Enable Ember check box and click Apply. The automation client must be set to find the Vista desk on the IP address and port you have just entered.

Ember PFL

The Ember PFL functionality is decoupled from the Vista desk PFL functionality and thus is also decoupled from the Vista monitoring. The Ember PFL function uses its own PFL bus, which can be patched to an output in order to connect it to a separate monitoring system. This means that an additional, unused PFL bus must be configured for Vista (Vista Configuration) in order to use Ember PFL. For a Vista 1, Vista 5 or Vista V which use “Bus Pfl s 1” for PFL, a second bus “Bus Pfl s 2” needs to be configured for Ember PFL. For a Vista 9 and Vista X which use “Bus Pfl s 1” for main PFL and “Bus Pfl s 2” for ALT PFL, a third bus “Bus Pfl s 3” needs to be configured for Ember PFL. VistaEmber does not automatically detect which PFL bus it has to use. This needs to be configured by setting the PFL bus number.

For a full list of the Ember controllable parameters, please refer to the service manual.

4.7.5 Settings: Reduced Function Set

Whis this setting, the more complex GC functions are hidden from the user GUI. The hidden functions are :

- Fader Ramps
- TC Reader/Generator
- N-1 Assign
- Signaling Configuration
- VSP Properties

4.7.6 Settings: General Patch Edit

When logged in as SysAdmin, the Enable General Patch Edit mode can be activated :

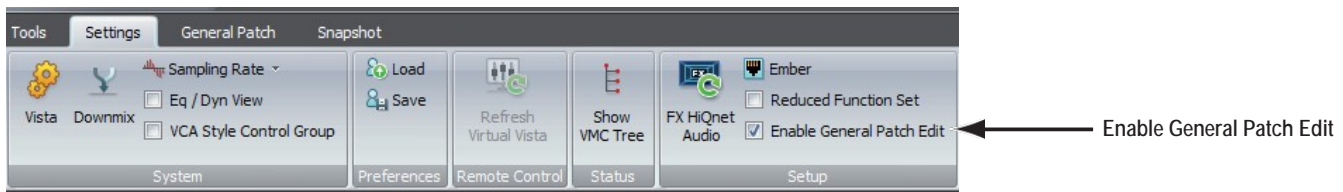

Then, the General Patch ribbon tab shows the Edit General Patch icon :
Now, two things are possible :



1. Change the place of a patch group
2. Create or edit user patch groups

Here the three areas where the Source groups, Target groups and the Page groups are found :



- Source Groups Are patch groups that navigate the source side of the generale patch only.
- Target Groups Are patch groups that navigate the target side of the generale patch only.
- Page Groups Are patch groups that can navigate both sides of the generale patch.

Change the place of a patch group Right-click on the group that you would like to change its place, and select

<Pick: Input Ports>

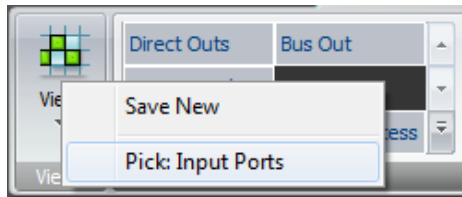

Then go to the desired new position and right-click again.

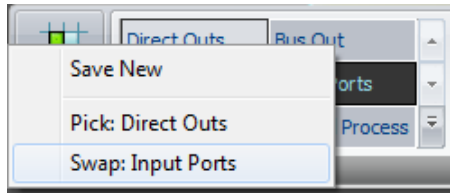

Now, select <Swap: Input Ports>. The two groups then swap their position.

Create or edit User Patch Groups

When in “General Patch Edit” mode, the General Patch view changes to Edit View. In addition to the vertical source list on the left side and the horizontal target list at the bottom of the matrix, the patch grid (matrix) disappears and is replaced by additional horizontal source- and target lists with search text-boxes on top. The content of these additional source / target lists matches the Patch Groups selected in the ribbon’s Source and Target patch group frames.

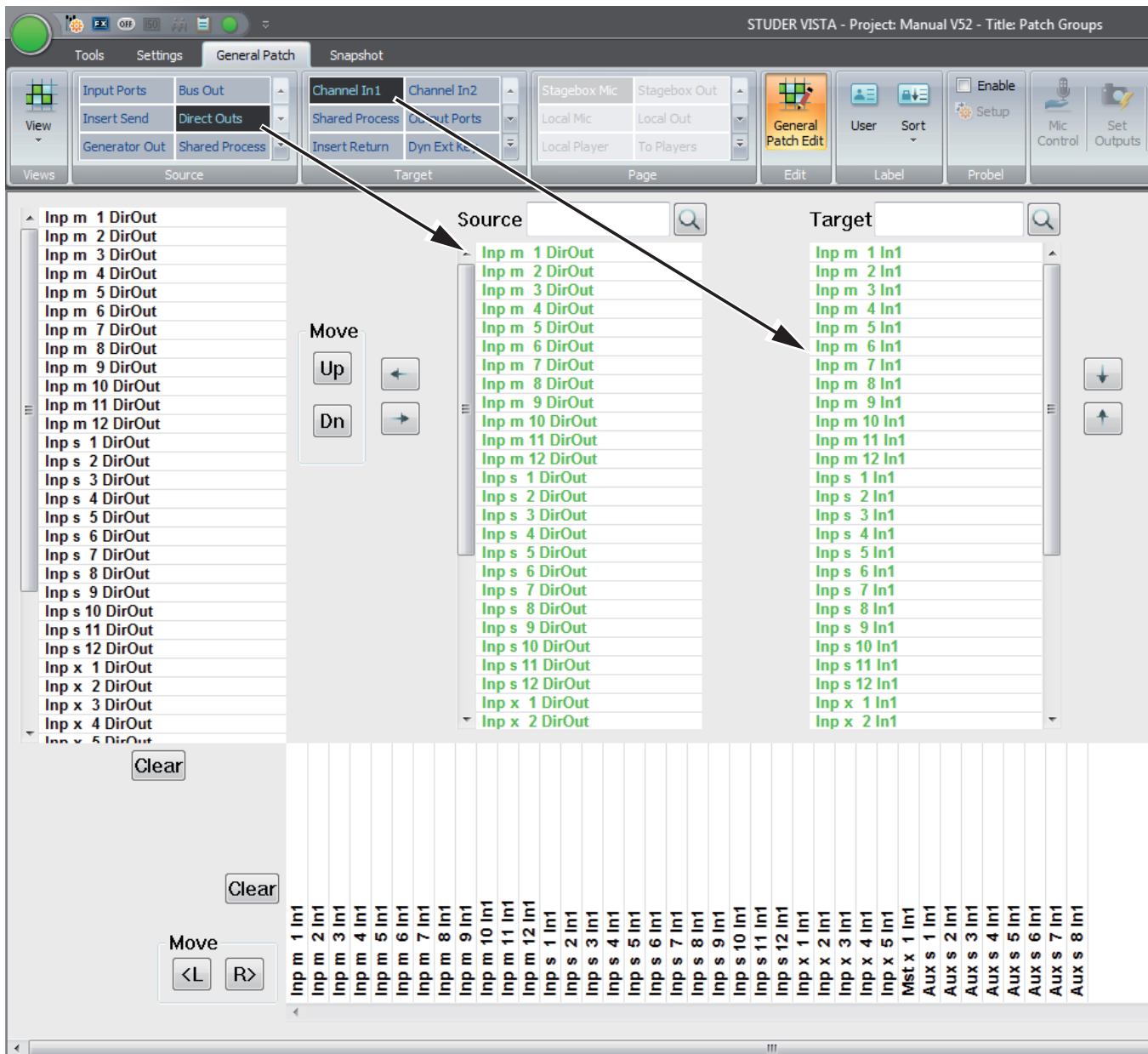

When in the General Patch Edit mode, the vertical source list on the left side and the horizontal target list on the bottom will show the sources and targets within the selected source and target groups which have been chosen before entering the edit mode. These source and target lists are the ones that get stored when saved to a User Patch Group. To start source and target groups from scratch, just press the **Clear** buttons next to the vertical and horizontal lists.

Adding Sources and Targets

The sources and targets shown in the two vertical source and target lists in the middle of the GUI can be assigned to the vertical source list on the left side and the horizontal target list at the bottom. If a source or target gets assigned, its colour changes to green in the two vertical lists in the center. Sources and Targets which are not assigned are in black font.

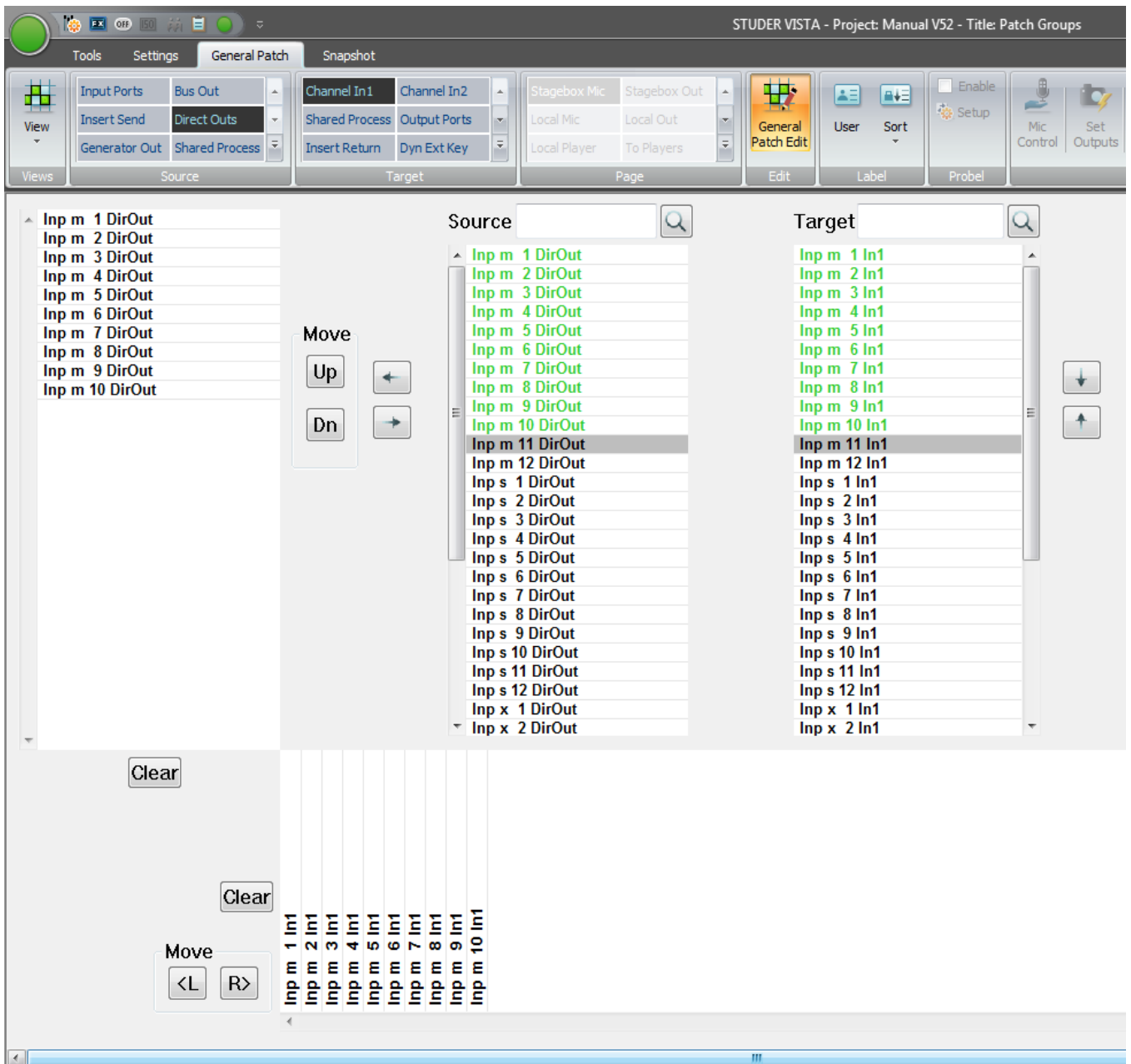

Assign a source or target to the list by double-clicking it. Deassign them by double-clicking on them in the list on the left and bottom. Multiple sources and targets can also be assigned and de-assigned by selecting several items (using Shift or Ctrl on the keyboard) at once and then using the arrow keys on the GUI.

It is possible to mix different source and target types within the Patch Group you are creating. For example, it is possible to create a source list that contains some Bus Outs, some Direct Outs etc.

In Edit mode, you can simply select another source or target Patch Group and add channels from these to the list which you are editing.

By using the Move Up / Move Down buttons, it is possible to change the source / target order of appearance in your edited /created Patch Group.

Save an edited / created User Patch Group

Now the edited source and target lists can be saved as new Source, Target or Page-Groups. If User Patch Groups already exist, it is also possible to save the edited lists by overwriting an existing User Patch Group.

Save as User Source Patch Group

Right-clicking on an existing User Source Group will open a context menu. Select either **Save New** to create a new User Source Patch Group or select **Update** and the User Patch Group you right-clicked will get overwritten. When saving, only the edited vertical source list on the left side will be saved to the User Source Patch Group.

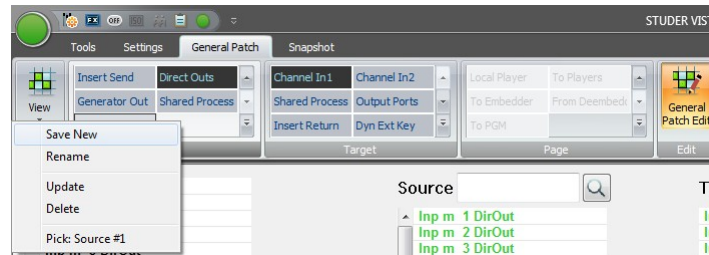

Save as User Target Patch Group

Right-clicking an existing User Target Group will open a context menu. Select either **Save New** to create a new User Target Patch Group or select **Update** and the User Patch Group you right-clicked will get overwritten. When saving, only the edited horizontal target list at the bottom will be saved to the User Target Patch Group.

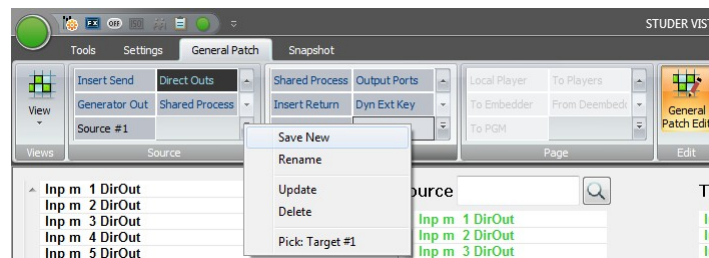

Save as User Page Patch Group

Right-clicking an existing User Page Group will open a context menu. Select either **Save New** to create a new User Page Patch Group or select **Update** and the User Patch Group you right-clicked will get overwritten. When saving, both the edited vertical source list on the left side and the horizontal source list at the bottom will be saved to the User Target Patch Group.

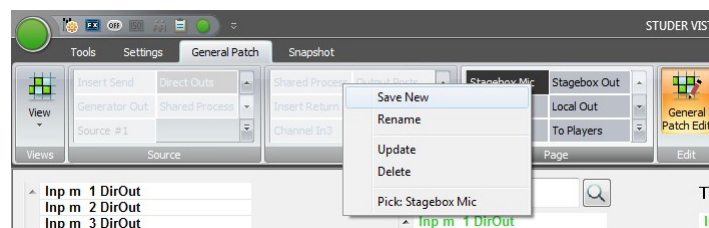

4.7.7 Settings: Edit Monitoring Files

The Monitoring menu item contains several functions regarding the Vista loudspeaker control:

Edit Monitor File:

This action brings up the Monitoring Setup editing utility. The title bar will display the name and location of the currently loaded monitor configuration.

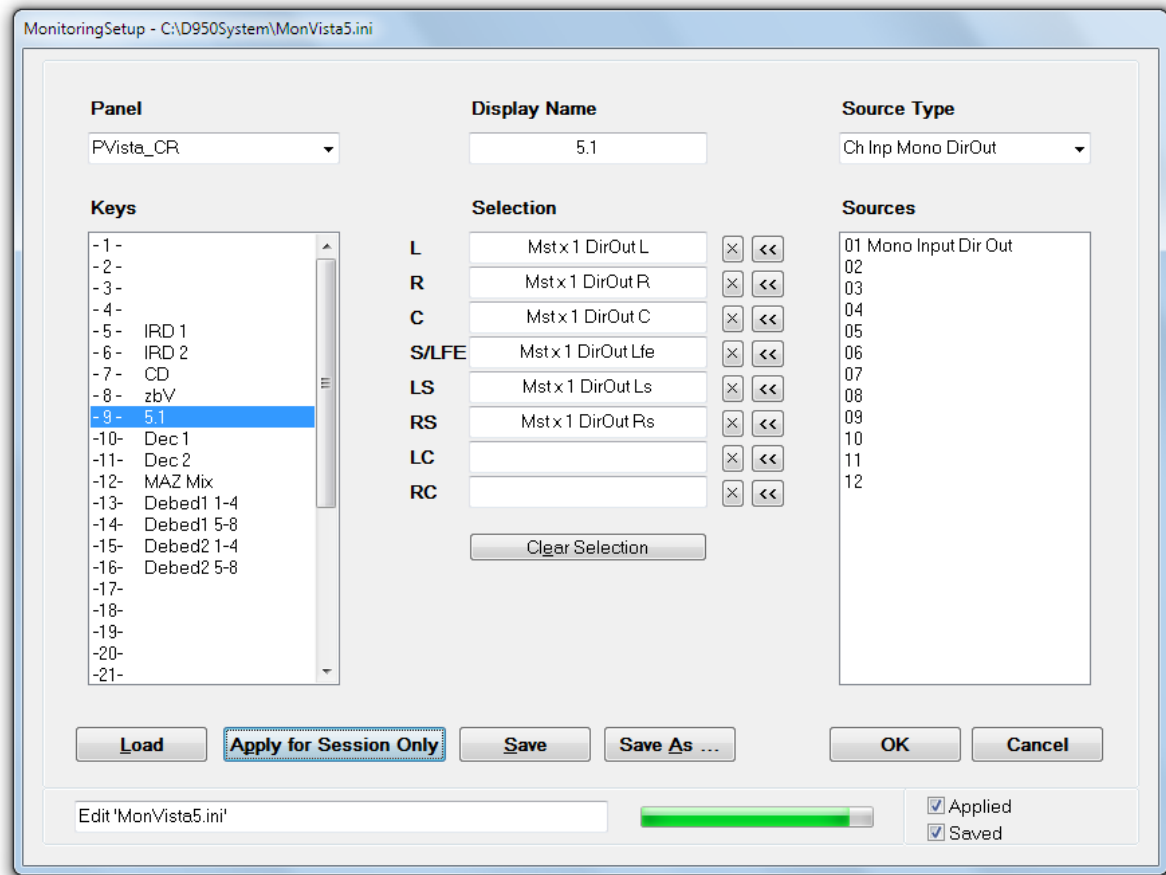

Panel Selection box: This box provides a pop-up menu used to select a control room or studio Assignable Source Selector panel installed in the control surface for editing. The Source Selector keys for the selected panel will be displayed in the Keys box, where they can be selected for editing. The name of the panel may also be edited using this box.

Note: *The four subpanels popping up on the screen upon activated option (experts only!) show up as individual panels with 12 source selectors each.*

Key Selection box: This box is used to select a specific Monitor Source Selector key for editing.

Display Name entry box: This is a name entry box for the selected Source Selector key. It will display the name of the selected key, which can be edited.

Speaker/Source Selection entry boxes: These fields are used to connect a digital audio source (such as a direct output) to a specific loudspeaker feed (such as left, right, center, etc.). This is accomplished by highlighting a source from the Source Selection list and assigning it to the desired loudspeaker feed using the appropriate double-arrow button (<<). When such an assignment is made, the source name will appear in the selected loudspeaker field. Selections may be cleared using the X buttons.

Clear Selection button: This button will clear all Speaker/Source selections made for that Monitor Source Selector key.

Source Type Selection box: This box provides a pop-up menu used to select the type of digital source for assignment (such as a mono master direct output or an AES interface). Once an item has been selected, all the sources of that type will be displayed in the Sources list below.

- Source Selection box:* This box displays a list of digital sources of a specific type that are available for assignment to loudspeaker feeds.
- Load button:* This button brings up a familiar Windows box from which an existing monitor configuration file can be loaded.
- Apply button:* This button applies the current monitor configuration file to the Vista. This is handy when testing a recently edited file or recalling a previously saved file.
- Save and Save As... buttons:* The Save button allows a previously saved monitor configuration file to be updated after editing. The Save As... button allows a new file to be named and created.
- OK and Cancel buttons:* The OK button accepts the current monitor setup and closes the window. Clicking OK does *not* apply or save the monitor configuration file. The Cancel button exits the monitor setup screen.
- Monitor File Name entry box:* This field is used to enter a name for a new monitor Configuration.
- Application Progress indicator:* This meter displays the progress of the loading of the monitor configuration file when it is applied to the console.
- Applied and Saved Status boxes:* These boxes display the status of the current monitor configuration file. If checked, the current file is applied to the console and/or saved.

To create a new monitor configuration file:

- First open the Monitoring Setup utility from the Monitor section of the SysAdmin menu.
- Select the desired Assignable Source Selector panel and key, using the lists on the left.
- Select a source type and source from the lists on the right.
- Highlight the selected source and click on the double-arrow (<<) button next to the desired loudspeaker feed in the Selection boxes. The source name will appear in the selected location. Once a key is selected, its name may be changed using the Display Name field.
- Repeat these steps to complete the necessary assignments. Once finished, the new file can be saved and applied to the console.

Please note that the edited file must be applied to the console before it takes effect.

Existing monitor configuration files can be edited by recalling them with the Load button and using the procedures described above.

4.7.8 Settings: Enable Monitoring Setup-Mode

To allow access to the speaker calibration, the Enable Setup function must be enabled. Please refer to [chapter 4.6.2.1.1](#).

4.7.9 Settings: Reinitialize Monitoring

This action will reinitialize the monitor system and reload the last used monitor configuration file. The monitors will mute during this operation.

4.7.10 Settings : Device Labels (Save and Apply)

This menu item lets you set-up the console for use with Device Labels. It is used for setup only !
For a detailed description, please refer to [chapter 4.4.2.6](#)

4.7.11 Settings: Use DeviceLabels

This option must be checked for using the console with Device Labels. It must be checked (active) for proper Device Labels functionality.
For a detailed description, please refer to [chapter 4.4.2.8](#).

4.7.12 Settings: Overwrite Channel User Label

This option must be checked for using the console with Device Labels. It must be checked (active) for proper Device Labels functionality.
For a detailed description, please refer to [chapter 4.4.2.8](#).

4.7.13 Settings: Configure ExternalRouter I/O

This opens a dialog window for External Router I/O Configuration - but only in the case if external router control is enabled on the system.

4.7.14 Settings: Connection Setup

If this button is pressed, the D23m/D21m I/O system will be reinitialized. This button is not used in normal operating mode, only when changes in the I/O system have happened, this button can be used for trouble shooting.

4.7.15 Settings: Regenerate Intelligent Fix Labels

Audio coming through the D21m I/O components is reaching the core over Studer's proprietary HD (high density) link in case of the SCoreLive. This link is present between the local hub(s) and the SCoreLive. Each link may carry up to 96 audio channels. Instead of displaying these channel numbers in the general patch, the software is able to give more intelligent names to the input and output ports shown in the general patch. You will then see frame numbers as well as card types and channel numbers within each card. This generation is automatically active whenever the D21m I/O system is present and the hub frame is connected to the console via a serial link. However, when recalling a snapshot containing the 'non intelligent' fixed labels (e.g. from older productions), this will overwrite the fixed labels as well and make the 'intelligent fixed labels' disappear. In this case, select **Regenerate Intelligent Fixed Labels** and update this snapshot.

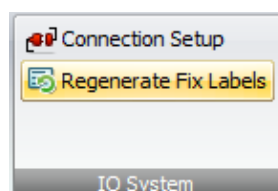

4.7.16 General Patch: Enable Pro-Bel Setup

This option must be checked (active) to enable the ProBel Setup functionality explained below.

4.7.17 General Patch: Pro-Bel Setup

This button starts the Pro-Bel setup process as explained in detail below :

4.7.17.1 3rd-Party Control of Console Patch (Native Pro-Bel P-02/08 Support)

Since SW version 3.5 of the Vista Software, these products are able to support Pro-Bel enabled devices natively, and so a second PC is no more necessary for this functionality. However, we do not recommend that existing installations are altered that are already in use with a second PC for Pro-Bel interfacing. *The explanations below are therefore intended for installation personal and not for the console operators.*

Supported Functionality Our implementation enables the ability to map certain Pro-Bel connect requests to a set of definable patch connections. The control of patch points is not restricted to set output patch points. It is possible to set any patch points within the console patch upon reception of a Pro-Bel command. The set-up procedure is done from the General Patch screen, where certain patches can be selected (by just selecting the affected targets) and which are being mapped to a Pro-Bel source/destination combination with a single click on a dialog.

Enabling Pro-Bel Setup In order to activate and see the **Setup Pro-Bel** button on the General Patch window, the system has to be in SysAdmin mode. The SysAdmin menu contains a General Patch sub menu and a **Use Pro-Bel on General Patch** item.



This setting will be written to the `D950System.ini` as well, resulting in the same behavior as if it was edited by hand in the first place. The button will then be visible whenever the system enters SysAdmin mode.

Enabling COM Ports for Use with the Pro-Bel Protocol

Ports that are used for Pro-Bel need to be specified in `D950System.ini` in the `[d950SerialPorts]` section. This gives the possibility to use non-standard data rates and parity settings.

```
[d950SerialPorts]
1= {p} COM1 baud=115200 parity=N data=8 stop=1
2= {b} COM6 baud=38400 parity=E data=8 stop=1
```

'b' is used to indicate Pro-Bel use. Only the COM ports defined in this way will be available in the Pro-Bel set-up dialog.

Pro-Bel Set-up Dialog With Pro-Bel Setup enabled, the Pro-Bel category displays the additional Setup - button.



When clicking on this button the system brings up the set-up dialog and enters Pro-Bel set-up mode.

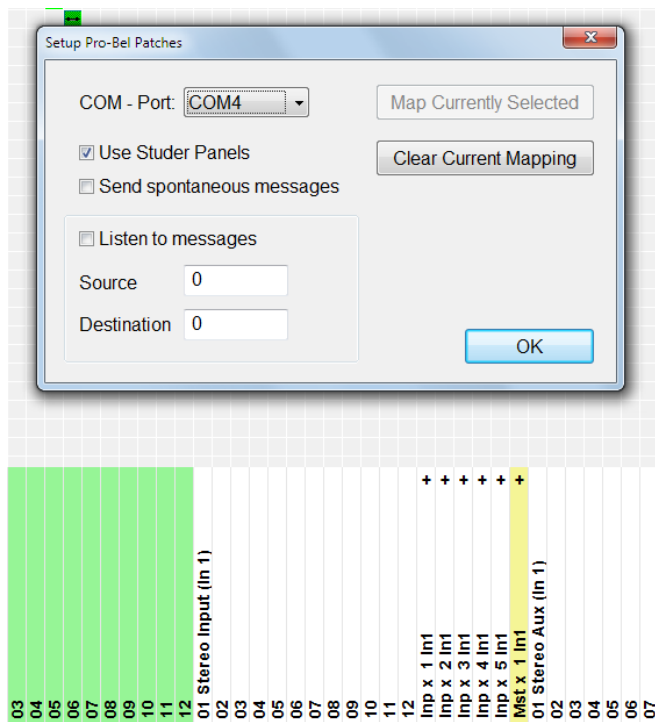

Targets with their respective connections can be selected by clicking on them in the list on the general patch. Selected targets change their color to pink to show their selection state.

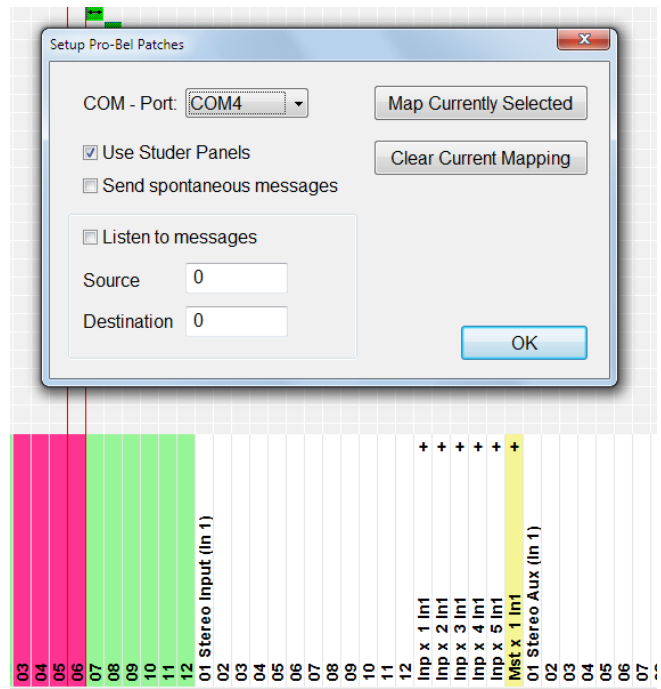

Clicking on the **Map Currently Selected** button maps the patches for the selected targets (the pink-colored ones) to the Pro-Bel connect command specified on the left.

With **Listen to messages** enabled, incoming connect messages are mapped to the edit fields on the dialog. To select targets affected by this connect command simply click on them in the target list of the general patch (color is set to pink).

Make sure to always associate the same Pro-Bel destination to the same set of targets.

Any connection on the patch may be mapped to certain Pro-Bel connect commands. You are not limited just to outputs or inputs!

With **Send spontaneous messages** enabled, the corresponding CONNECTED message is sent whenever one of the defined patch combinations matches the same combination as when they were defined.

Files Used to Save Pro-Bel Set-up

The system creates human-readable files (ini format) in the D950System directory to save the set-up. The files are named according to the COM port used: PortX.Pro-Bel – with X being the COM port used.

Example for a .Pro-Bel File

```
[TARGET_1 SOURCE_6]
Im23 Inp m 23 In1 left=D12L AES B 1 In4L left
Im24 Inp m 24 In1 left=D12L AES B 1 In4L left
[TARGET_1 SOURCE_7]
Im23 Inp m 23 In1 left=D11R AES B 1 In3R left
Im24 Inp m 24 In1 left=D11R AES B 1 In3R left
[TARGET_1 SOURCE_4]
Im23 Inp m 23 In1 left=
Im24 Inp m 24 In1 left=
[TARGET_0 SOURCE_0]
Im23 Inp m 23 In1 left=D11R AES B 1 In3R left
Im24 Inp m 24 In1 left=D11R AES B 1 In3R left
Im25 Inp m 25 In1 left=
Im26 Inp m 26 In1 left=
```

This file basically has a section for each used Source/Target combination. The fixed labels are being used; 'left' is appended for left or mono sources/targets, and 'right' is appended for right sources/targets.

Alternatively a short form of this file may be used in order to support the standard case where all combinations of certain inputs and outputs should be under control of an external device, there is a new file format introduced allowing to only list the required inputs and outputs.

The alternate file format looks as follows:

```
[TARGETS]
1=i 1 B 1 Ch 1 left
[SOURCES]
1=I 1 B 1 Ch 1 left
```

This example defines Pro-Bel destination 1 to be 'i 1' output interface and Pro-Bel source 1 to be 'I 1' output interface using the patch points fixed label syntax.

The format is:

`destination | source=fixed label of patch element + left`

The appended 'left' is kept on purpose in order to keep both formats compatible.

Note: If a source or destination is listed twice by accident, once in the simple format and once in an x/y combination, the simple format has priority, and the x/y listing isn't recognized. This situation is regarded as an error and should not occur in regular cases.

4.7.17.1.1 Pro-Bel P-08 support

In case the user wants to extend the number of controlled patch points to above 1'000 it is recommended to use the Pro-Bel P-08 protocol. This protocol also supports transferring labels from 3rd party router systems at the same time. However, no control over internal patches such as patching from an input port to an input channel is provided. Only one port can be used for P-08. Therefore continue to use P-02 in case of multiple controllers present or if you want to set system internal patches, e.g. channel input patches.

A special mapping file is present in the system translating Vista interfaces to Pro-Bel P-08 commands (no 'fixed labels' used):

```
Pro-Bel SW-P-08 Issue 21
2/1/0/0/0/0,1,1,0,
2/1/0/0/0/1,2,1,0,
2/1/0/1/0/0,2,2,0,
2/1/0/1/0/1,1,1,5,
2/4/0/0/0/0,9,0,0,
2/4/0/0/0/1,0,9,0,
2/4/0/1/0/0,0,0,9,
```

The format is as follows:

IO/InterfaceType/BoardNumber/PortNumber/ChannelNumber/PatchNumber, Index, Matrix, Level

| | |
|----------------------|--|
| InterfaceType | 1 = AES in, 3 = Madi in, 9 = IO21 in 4 = AES out, 8 = Madi out, 10 = IO21 out |
| BoardNumber | Certain interfaces use board numbers |
| PortNumber | Certain interfaces use port numbers |
| ChannelNumber | Interfaces do not use channel numbers and it's usually 0 |
| PatchNumber | The zero-based index of the patch of the selected board and port |
| Index, Matrix | Index and Matrix as defined in the Probel specification |
| Level | Level is evaluated for sources only. <i>As this might be used differently with OnAir 3000 systems, we recommend using 0 for the Level.</i> |

4.7.17.1.2 Exclude Certain Patch Targets from Being Changed by Snapshots

Some customers are using our consoles as audio routers for other studio installations, controlling the internal router by protocols such as Pro-Bel or ARMI. When recalling console snapshots, the patch points set by these devices are reset to the value of the snapshot, even if this was not always requested. Since software release 3.4 it is possible to define certain patch targets as 'isolated from snapshot recalls'. In other words, the user defines the patch outputs are controlled by Pro-Bel/ARMI devices and therefore makes those targets completely independent from snapshot recalls by the console operator. This set-up is typically done once on a system. See service instructions for information on how to set-up this isolation.

4.7.17.1.3 Label Import from 3rd-Party Systems

In addition to getting patch control it is possible to exchange label information with external router systems, such as Pro-Bel and Grass Valley. Using a serial connection, a permanent label exchange can be set up in such a way that the 'device labels' used in Vista and D950 systems are permanently overwritten by received labels from the 3rd party router. This means that you will automatically see the name of the original sources on your channel strip, even if a large routing system is placed before your console.

Studer supports two label exchange protocols: Pro-Bel SW-P-08 and Grass Valley Group Series 7000. Normally this feature is only used for label *import* from the external devices. However, when using the Pro-Bel SW-P-08 proto-

col, also *export* of output interface labels is supported. It is therefore possible to connect two Vistas together and get the labels automatically from one Vista transferred to the second.

Note: The Pro-Bel P-08 interface also allows patch control and not only transfer of labels.

4.7.17.1.4 Support of External Monitoring Source Selector Panels

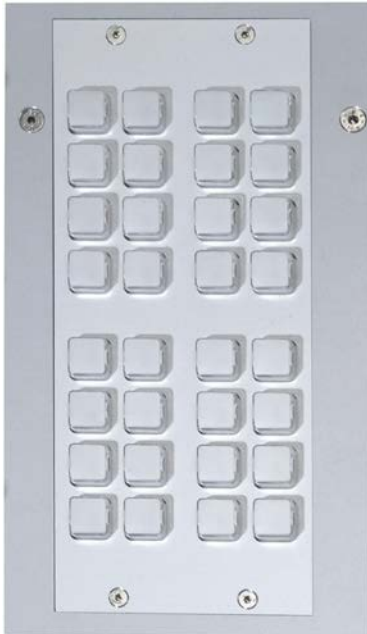

As an alternative to controlling patch points of the console by using 3rd-party controllers (Pro-Bel protocol), Studer offers a ‘mini’ Pro-Bel controller module. The module may be mounted within the Vista console or anywhere externally. It hosts 32 freely programmable keys to set any number of patch points within the console. Each key may be defined to set a certain patch point (or a set of patch points.) The keys on the hardware panel are illuminated, if all of the defined patch points are currently set. As soon as one of them is cleared or changed, the key gets dark. This intelligence allows free grouping of the 32 keys to e.g. 16 groups of two sources each, or to one single group of 32 sources. Any combination in between is possible. It is also possible to use 16 keys as one group while using the remaining keys as two groups of eight, for example.

If a set of keys are setting patch points to the same destination they are automatically recognized as a group and therefore their illumination will automatically indicate the correct patch state. Rule: A key is illuminated as long as all defined patch points are set. If at least one of them is changed (e.g. by pressing another source selector or by the console’s touch pad) the key becomes dark.

Note: Switching patch points is not only possible to outputs of the console, but everywhere within the patch (e.g. input patches to input channels or inserts). Therefore the Studer panel may also be used to switch any number of input patches of the console to different inputs.

Patch Point Isolation

These patch points cannot be isolated against changes by snapshot recalls, unless the inputs of the channels are isolated. The general function of isolating patch points against snapshot recalls may be applied to output patches only.

Patch Mapping Setup

The setup on the console side happens in the same way as when setting up normal Pro-Bel control. The panel itself needs an address set. This address will guarantee that multiple panels may work at the same time. Multiple panels may be connected to one serial port of the console. Please refer to the service manual for more details.

4.7.18 Snapshot: Output Snapshot Isolation

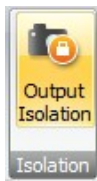

By pressing the button Output Isolation, output patch connections can be protected against changes from snapshot recalls.

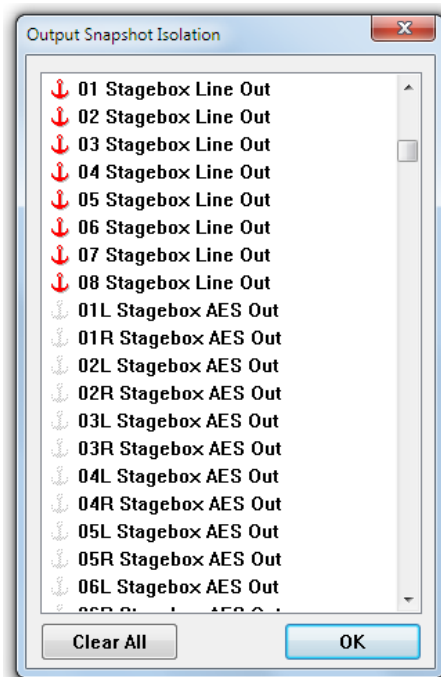

4.8 Fifth Level: The Surveyor

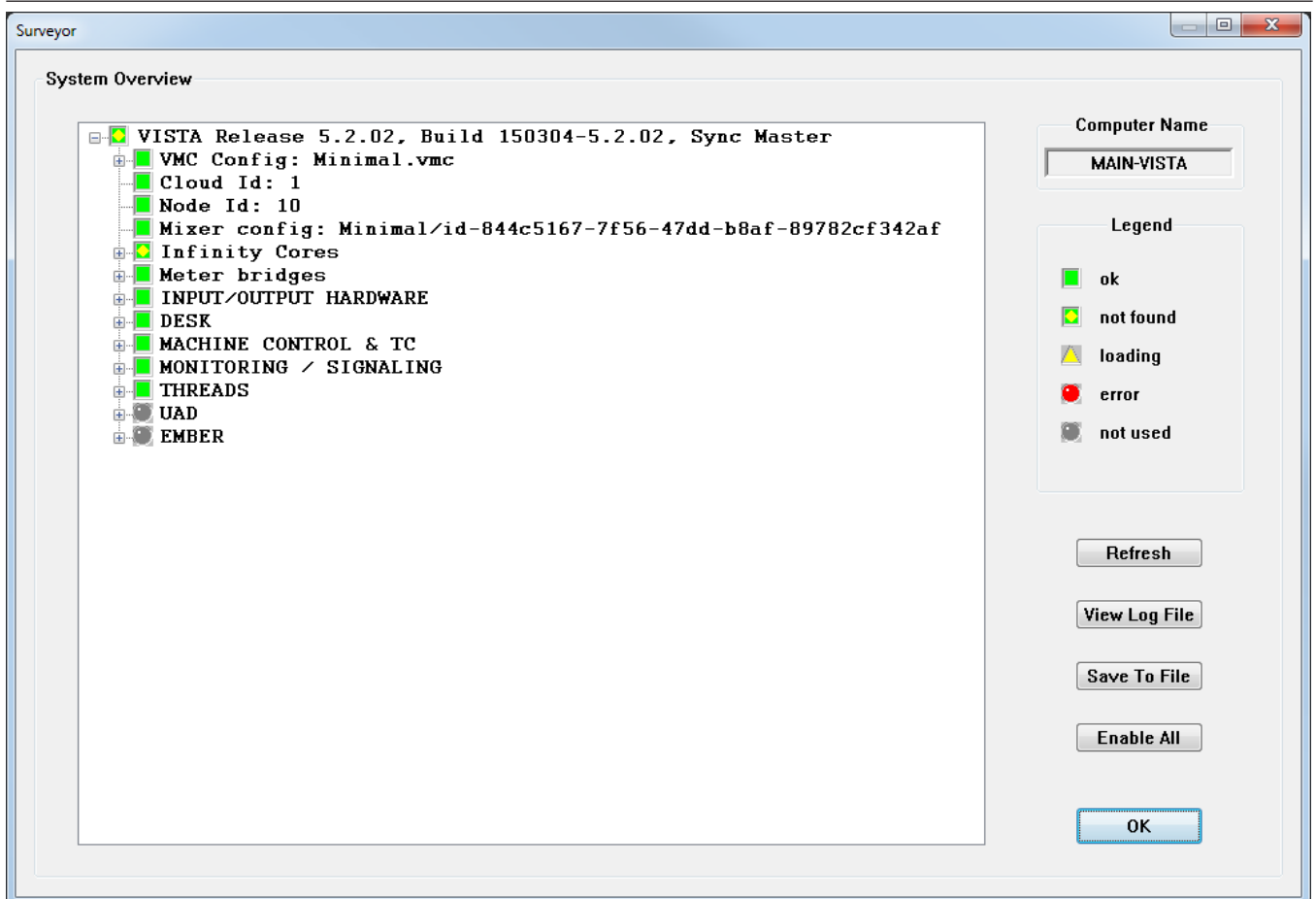

Vista constantly monitors the status of all major hardware and software systems. This information is provided to the user via the Surveyor. The Surveyor is also the primary diagnostic tool used for troubleshooting and fault finding. The Surveyor displays its information in two ways:

- The Icon/Button shown on the left hand side of the Ribbon menu bar;
- The Surveyor page.

The Surveyor Icon/Button: The Surveyor Icon/Application Menu Button is always located in the Ribbon menu bar. It is intended to keep the operator informed about general system status. The icon changes to indicate the overall condition of the Vista. These indications are as follows:



Grey circle: The system is starting up.



Green circle: The system is working and OK.



Green circle with yellow exclamation mark: Not Found. A system element cannot be found. This is sometimes seen while a configuration is loading. If this icon remains on, a problem is indicated



Red circle: Error. An error, fault, or failure is detected in the system. If this icon remains on, a problem is indicated..

Surveyor Page: The Surveyor page may be opened from the SysAdmin menu or by clicking on the Surveyor button. The main window contains all the major system elements displayed as a directory tree. The status icon at the start of each directory indicates the general status of its contents. These icons utilize the same indication system as the Surveyor button (see above).



Green square: OK. This system element operates normally;



Green square with yellow diamond: Not Found. A system element cannot be found. This is sometimes seen while a configuration is loading. If this icon remains on, a problem is indicated.



Tip Sometimes an element cannot be found simply because it has not been switched on.



Yellow triangle: Loading. This system element is booting (info in the status bar);



Red circle: Error. An error, fault, or failure is detected in this system element.



Grey circle: Not Used. A system element is defined but is not in use.

If all elements display the OK icon (green square), the system will operate normally. If any of the directories display the Error icon, it can be opened to determine which of its contents has a problem. Since some system elements have many subsystems, several nested subdirectories might be contained within the main directories. As with the typical Windows directory system, directories that contain subdirectories have a '+' symbol on the left of the status icons. To open these directories either click on the '+' symbol or double-click the directory name or status icon. It might be necessary to open several directories to find the specific element that is having a problem.

Surveyor Tools: The Surveyor features several tools to enhance its operation. These are available as buttons on the Surveyor page:

- *Refresh:* Real-time updates of system element icons are not provided when the Surveyor page is open. If a fault is corrected during troubleshooting, the system must be re-interrogated before the Surveyor page will display the result. Clicking the Refresh button will survey the entire system and display the current the status of all elements.
- *View Log File:* This tool allows the Vista log files to be viewed from within the Surveyor.
- *Save Log File:* This button saves the current Vista log file.
- *Enable All:* It is possible to tell the Surveyor to ignore some problems by right-clicking on one of the red symbols. This will make the main symbol in the task bar remain green, even if there is an error reported in some sub-area. 'Enable All' clears these exceptions and makes the Surveyor work as usual. *Inactivated sub-areas are always re-activated upon system startup for safety reasons.*
- *OK:* Clicking this button will close the Surveyor page.

Surveyor Information: When it is initially opened, the Surveyor displays some information without the need to open any directories or subdirectories:

- *Computer Name:* This field displays the name of the PC that is being used to control the Vista system;

- *Vista System*: This is the main directory in the Surveyor, which contains all of the other system element subdirectories. It's name displays the Vista software Application Release number (version) and the Build number. This directory will always be open to show the primary system element subdirectories (and their status) when the Surveyor is opened;
- *VMC Session Config*: This item displays the currently loaded Session Configuration file in a directory name format, such as: `C:\D950SYSTEM\VMC directory name\VMC name.vmc`.

☞ **Tip** Other current system files (such as monitor files) may be found in the Surveyor, but will be nested within subdirectories.

CHAPTER 5

| | | |
|----------|---|----------|
| 5 | AutoTouch Plus Dynamic Automation | 4 |
| 5.1 | Basics..... | 4 |
| 5.2 | Getting Started Quickly | 8 |
| 5.2.1 | The Virtual ACU (Automation Control Unit) Window..... | 8 |
| 5.2.2 | Automation Keys on the Vista 5 BE Desk | 10 |
| 5.2.3 | Mix Passes..... | 11 |
| 5.2.4 | Write Zones | 12 |
| 5.2.5 | How to..... | 13 |
| 5.3 | The Details..... | 15 |
| 5.3.1 | About this Chapter | 15 |
| 5.3.2 | Features | 16 |
| 5.3.3 | Operational Philosophy | 18 |
| 5.4 | Essential Concepts..... | 20 |
| 5.4.1 | Static and Dynamic Objects | 20 |
| 5.4.1.1 | Static Objects | 20 |
| 5.4.1.2 | Dynamic Objects..... | 22 |
| 5.4.1.3 | Mix Snapshot | 22 |
| 5.4.2 | Touch & Un-Touch Events | 23 |
| 5.5 | File Management | 24 |
| 5.5.1 | Mix Tree..... | 25 |
| 5.5.1.1 | Passes in the Mix Tree..... | 26 |
| 5.5.1.2 | Active Pass | 28 |
| 5.5.1.3 | Mix Tree Display Modes | 28 |
| 5.5.1.4 | Mix Tree Click Functions..... | 31 |
| 5.5.2 | Creating a New Mix | 33 |
| 5.5.3 | Loading an Existing Mix..... | 34 |
| 5.6 | Mix Pass | 35 |
| 5.6.1 | Mix Pass Stack | 36 |
| 5.6.1.1 | Mix Comparison..... | 37 |
| 5.6.1.2 | Undo/Redo | 37 |
| 5.6.1.3 | Dump..... | 39 |
| 5.7 | Control Modes | 40 |
| 5.7.1 | Read | 41 |
| 5.7.2 | Write | 42 |
| 5.7.3 | Trim..... | 43 |
| 5.7.4 | Isolate..... | 46 |
| 5.7.5 | Control Mode Entry | 46 |
| 5.7.5.1 | Global Mode Entry..... | 47 |
| 5.7.5.2 | Mode Entry..... | 49 |
| 5.7.6 | Control Mode Indicators | 49 |

| | | |
|-----------|---|----|
| 5.8 | Touch and Hold | 52 |
| 5.8.1 | Touch and Un-Touch | 52 |
| 5.8.2 | Touch Record..... | 53 |
| 5.8.3 | Touch Hold | 54 |
| 5.8.4 | Touch Record + Touch Hold..... | 55 |
| 5.8.5 | Held Controls..... | 56 |
| 5.8.5.1 | Held Plays Mix | 56 |
| 5.8.6 | ISO (Auto Mode) Key Function | 57 |
| 5.8.6.1 | Modified Un-touch Inverts | 58 |
| 5.8.6.1.1 | Option Modified Un-Touch Inverts <Touch Record> | 58 |
| 5.8.6.1.2 | Option Modified Un-Touch Inverts <Touch Hold>..... | 59 |
| 5.9 | Global Record..... | 62 |
| 5.9.1 | Preselectors | 62 |
| 5.9.2 | Manual Punch-In/-Out | 63 |
| 5.9.3 | Write Zone | 63 |
| 5.9.4 | Auto Punch-In/Out..... | 66 |
| 5.9.5 | Auto Global Punch-In/Out..... | 66 |
| 5.10 | Data Transition Behavior..... | 67 |
| 5.10.1 | Write To: | 67 |
| 5.10.2 | Extend Back To: | 71 |
| 5.10.3 | Glide | 73 |
| 5.11 | Switch Automation | 76 |
| 5.11.1 | Switch Classifications..... | 76 |
| 5.11.2 | Switch Control Modes | 78 |
| 5.11.3 | Switch Operation | 79 |
| 5.11.3.1 | Press and Release | 80 |
| 5.11.3.2 | Press and Hold..... | 81 |
| 5.11.3.3 | Modified Press Function..... | 82 |
| 5.12 | Graphical Controller Automation | 83 |
| 5.12.1 | General Patch..... | 83 |
| 5.12.2 | Channel Patch..... | 85 |
| 5.13 | Other Automated Functions | 88 |
| 5.13.1 | Bus Assignments..... | 88 |
| 5.13.2 | Snapshots/Presets..... | 89 |
| 5.13.3 | GC Menu Items..... | 90 |
| 5.14 | Mix Protection | 92 |
| 5.14.1 | Protection Sets | 93 |
| 5.14.1.1 | Creating Protection Sets | 93 |
| 5.14.1.2 | Saving Protection Sets | 95 |
| 5.14.1.3 | Loading Protection Sets..... | 96 |
| 5.14.2 | Applying Mix Protection | 97 |
| 5.14.3 | Removing Protection | 98 |
| 5.14.4 | Isolate via Protection | 99 |

- 5.15 Miscellaneous Controls/Modes 100
 - 5.15.1 Mix On 100
 - 5.15.2 View Dynamic 100
 - 5.15.3 Scene Capture/Recall 101
- 5.16 Special Operating Modes 102
 - 5.16.1 Stop Frame Automation 102
 - 5.16.2 Read Lock 103
- 5.17 Offline Mix Editing 104
 - 5.17.1 Event List Editing 104
 - 5.17.2 OFLA Editing 109
 - 5.17.2.1 Object Picker 112
 - 5.17.2.2 Channel Selector Window 113
 - 5.17.2.3 Object Selector Window 114
 - 5.17.2.4 Channel/Object Tree Display Area 115
 - 5.17.2.5 Function Controls 118
 - 5.17.3 Mix Controls 119
 - 5.17.3.1 Active Mix 119
 - 5.17.3.2 Spread Source Mix 121
 - 5.17.3.3 Merge Mix 122
 - 5.17.3.4 Update Snap Source Mix 124
 - 5.17.4 Timecode Controls 125
 - 5.17.4.1 General Information 125
 - 5.17.4.2 Editing Timecode Entries 125
 - 5.17.4.3 Timecode Entry Controls 127
 - 5.17.4.4 Locking Timecode Fields 128
 - 5.17.5 Selected Objects Display 130
 - 5.17.6 Edit Types 131
 - 5.17.7 Offline Editing Tutorial 132
- 5.18 User Files 133
- 5.19 Virtual ACU Window Survey 136
- 5.20 Desk Automation Controls 140
- 5.21 Auto Touch Plus Window 143
- 5.22 Mix Options 146
 - 5.22.1 Saving/Loading Mix Options 147
 - 5.22.2 Control Mode Options 150
 - 5.22.3 Glide 151
 - 5.22.4 Hold 153
 - 5.22.5 Master Panel 154
 - 5.22.6 End Of Pass 156
 - 5.22.7 Miscellaneous 157
- 5.23 GC Automation Menu 158
- 5.24 Hot Keys 159

5 AUTOTOUCH PLUS DYNAMIC AUTOMATION

5.1 Basics

Since SW V4.2, the AutoTouchPlus dynamic automation (up to then used on the larger Vista consoles only) was made available for Vista 5 BE as well, making it even more versatile.

Dongle In order to activate the hardware keys described below, a dongle is required. It is plugged into the **CUSTOM PANEL GPIO** socket at the rear of the desk (32-fader version shown):

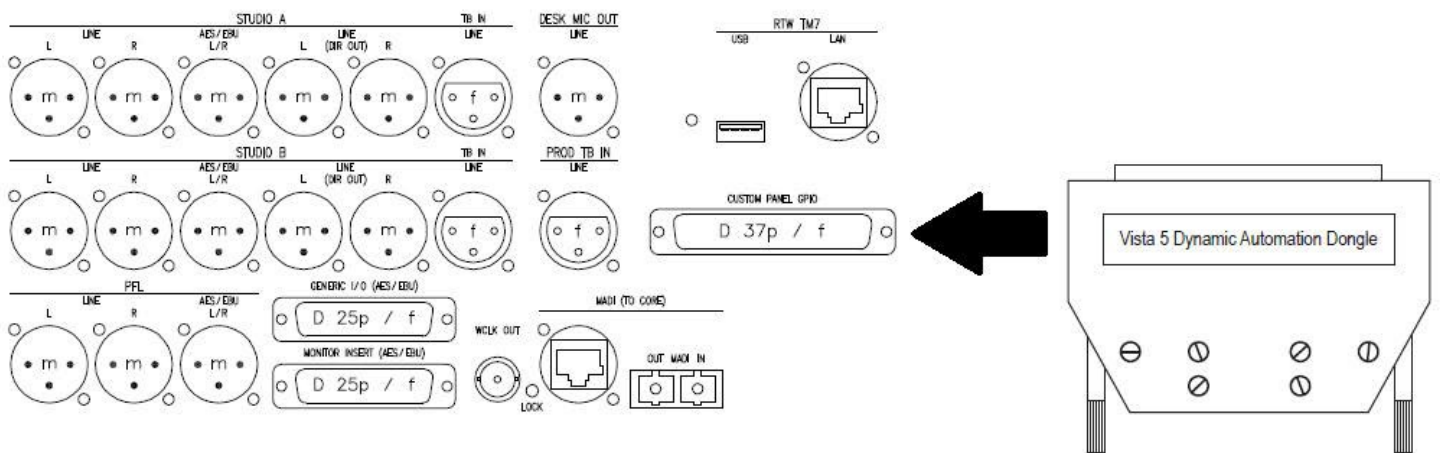

System Start Depending on the desired operating mode (static, i.e. snapshot automation, or dynamic, i.e. with AutoTouchPlus dynamic automation), start the system using one of the two GC screen icons.

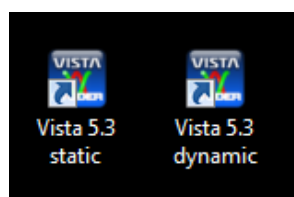

Note *Static (snapshot) and dynamic automation cannot be used at the same time.*

If *Virtual Vista* (chapter 2.11) is used for controlling the DSP core in parallel with the desk, it always starts in the same mode – static or dynamic – as the console was started in. In dynamic mode, however, operation is much more convenient with the touch-sensitive desk controls. In dynamic mode, Virtual Vista has a limited range of applications, such as entering and editing labels.

Time Code Vista 5 BE utilizes MIDI time code. For synchronization to LTC, an external, third-party converter such as the one in the picture below is required.



Operation:

Three GC windows are provided for AutoTouchPlus operation, as shown below:

Virtual ACU Due to space restrictions on the Vista 5 BE operating desk, most of the AutoTouchPlus functions are operated from the GC screen, using the 'virtual' automation control unit window (ACU). In order to open it, system administrator (admin) rights are required. If logged-in as administrator, the Automation tab will have an additional Virtual ACU item, as shown below:

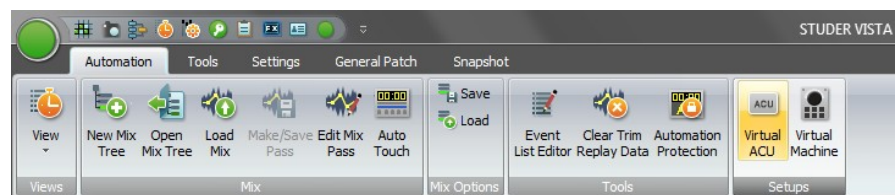

Activating it will open the ACU window in the GC. The other two windows also needed during AutoTouchPlus operation (the Generator and the Auto Touch Plus windows) can be opened by a click on their respective icons, as shown in the screenshot below.

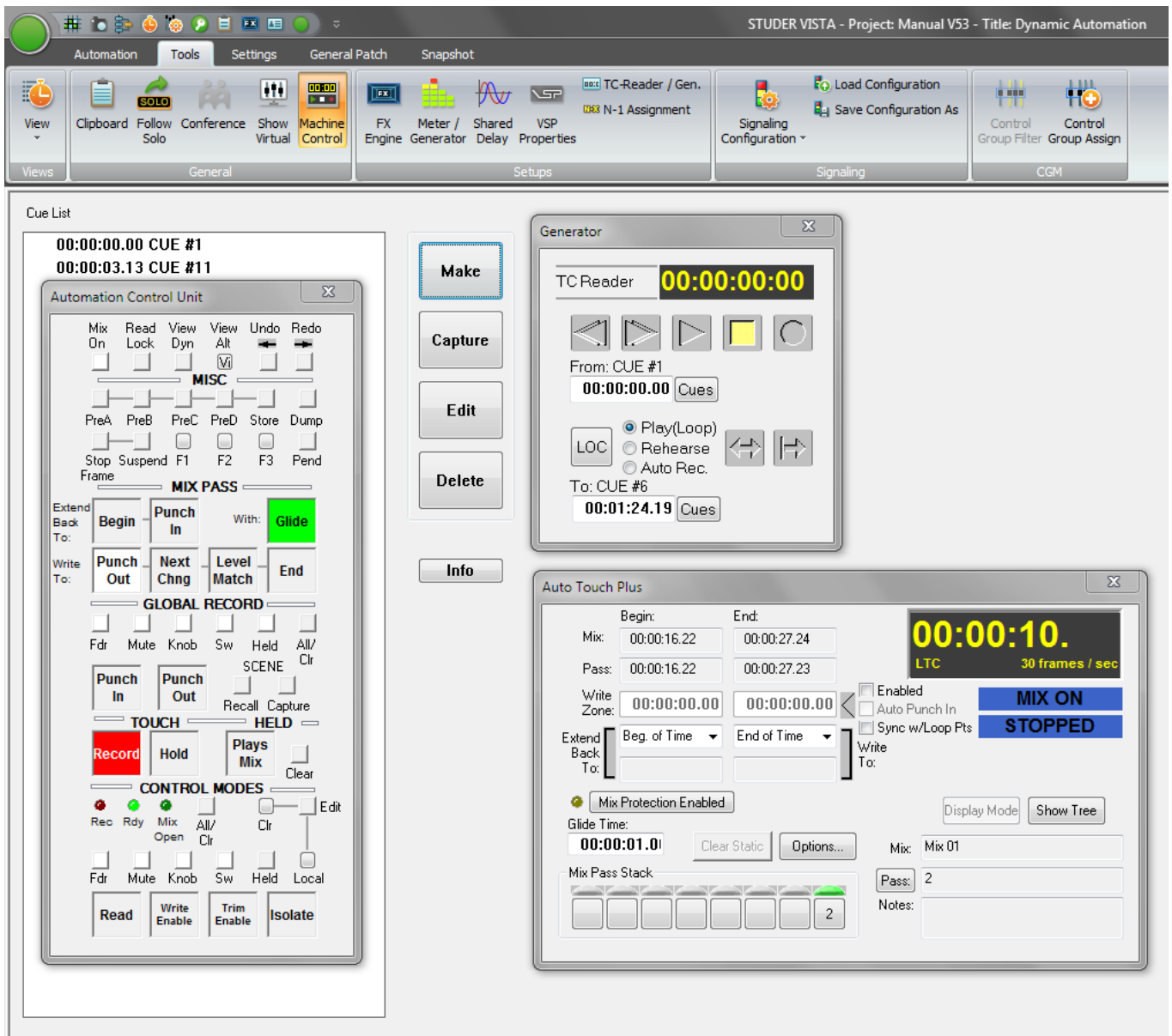

Definitions:

Objects

An 'object' in the context of the AutoTouchPlus automation is any channel parameter, such as a fader, a key (for e.g. switching an EQ on and off), or a knob (for adjustment of anything like gain, etc.).

'Held' Objects

This is an object being touched with a finger (or an object after being un-touched, but with the un-touch suppressed by a special mode). Held objects are indicated by displayed and underlined parameter values (such as the fader value in dB).

5.2 Getting Started Quickly

This short introduction to the AutoTouchPlus Automation is meant to give the user an easy entry point in order to start working with the dynamic automation. For simplicity some facts are not totally accurate and may have exceptions. Also it is possible to modify the behavior of AutoTouchPlus automation very much by varying option settings. In order to get a detailed overview of all available functions, please refer to [chapters 5.3](#) and up.

For Beginners We recommend to reset the automation system to the factory default settings. This is done by exiting the Vista application and deleting the C:\D950system\D9500f1a.mop file. After restarting the application, you have the factory default settings applied.

5.2.1 The Virtual ACU (Automation Control Unit) Window

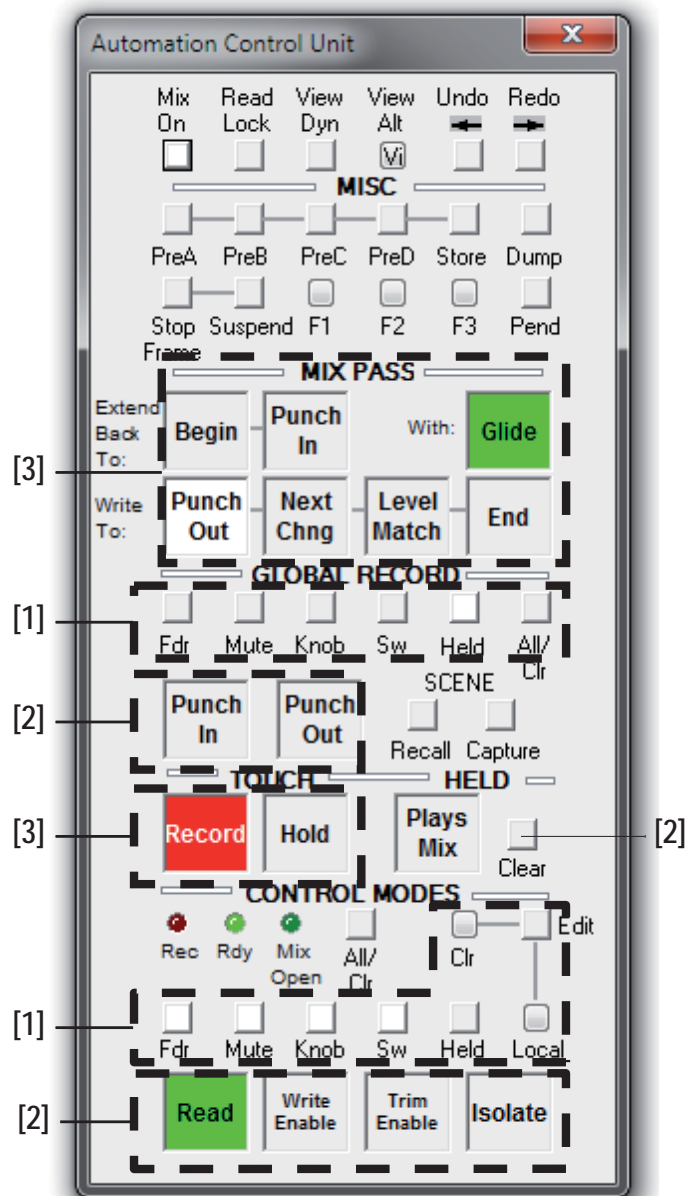

Most buttons in this window can be roughly divided into three groups:

- [1] **Preselector Buttons** These buttons select the group of functions that will be influenced by the action buttons located below them: **Fdr**, **Mute**, **Knob**, **Sw**, or all currently **Held** objects. The preselectors for faders, mutes, encoders/knobs, and switches influence the whole desk, not only specific channels.
- [2] **Action Buttons** These buttons perform an immediate action when clicked, such as:
- **Punch In, Punch Out**
 - Set objects into **Read**, **Write Enable**, **Trim Enable**, or **Isolate** mode
 - **Clr** (clear) the ‘held’ state of all held objects.
- [3] **Mode Buttons** These buttons put the automation into a specific mode, influencing its behavior for the next time the corresponding event occurs, e.g.:
- **Glide** will switch on or off the glide mechanism for *upcoming* punch-outs.
 - **Hold** will suppress the *detection* of the physical un-touch of an object. The object will therefore stay in a ‘held’ state.
- Note:** This button will only influence *future* physical un-touch of objects.
- **Record** tells the system whether it should punch-in when (upcoming) touches are being detected. If **Record** is off, the automation is in an ‘audition’ or ‘rehearse’ mode.
 - **Write to: Level Match, Next Chng, End, and Punch Out** will write the value *at the time of punch-out* possibly further ahead, rather than immediately stop recording. The neutral setting is **Punch Out**. This will record no more after punch-out.
 - **Write to: Begin, Punch In:** These buttons can only be activated *before* starting a mix pass. They will write the value at the time of punch-out as a constant value back to the begin (setting **Begin**) or back to the point where the user punched in (setting **Punch In**).

Examples

In Write Enable mode:

1. Correcting a constant value throughout a mix (**Write to: Begin**)
2. In a music mix, when a solo is played: For finding a value while listening and applying the final value to the whole passage (**Write to: Punch In**).

In Trim Enable mode:

1. Trim an object back to the beginning of a mix while keeping its movements (**Write to: Begin**)
2. Trim an object by a constant value between punch-in and punch-out point, while keeping the movements (**Write to: Punch In**).

5.2.2 Automation Keys on the Vista 5 BE Desk

Desk Controls The controls used for automation on the Vista 5 BE desk are marked below:

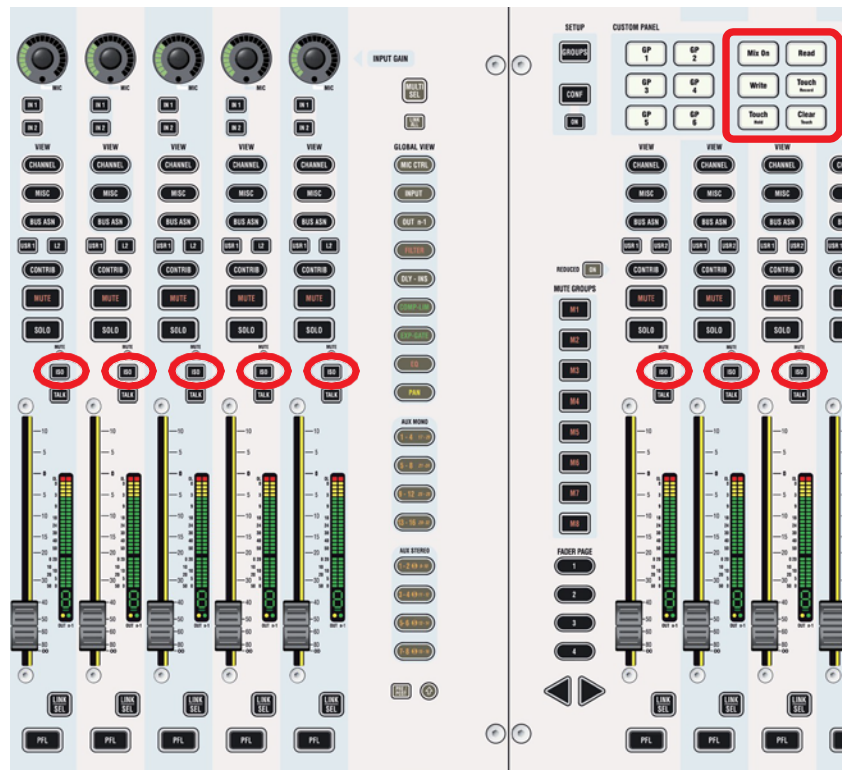

ISO (AUTO MODE) Toggles between different automation modes: READ, WRITE, TRIM, ISOLATE. As a standard, only the objects selected in the ‘preselector area’ of the ACU window (e.g. FADER) are toggled, but not the whole channel. This key has also the important function to suppress the detection of a physical touch or un-touch of any objects. It is therefore possible to modify a value without putting the object into ‘held’ mode. Or – vice versa – it is possible to physically un-touch an object while that the automation doesn’t detect the un-touch (object is still considered as ‘held’). For this reason the **ISO (AUTO MODE)** key is sometimes also referred to as ‘modifier key’.

Hardware Keys The most important AutoTouchPlus commands have been assigned to the six **CUSTOM PANEL** keys shown below.

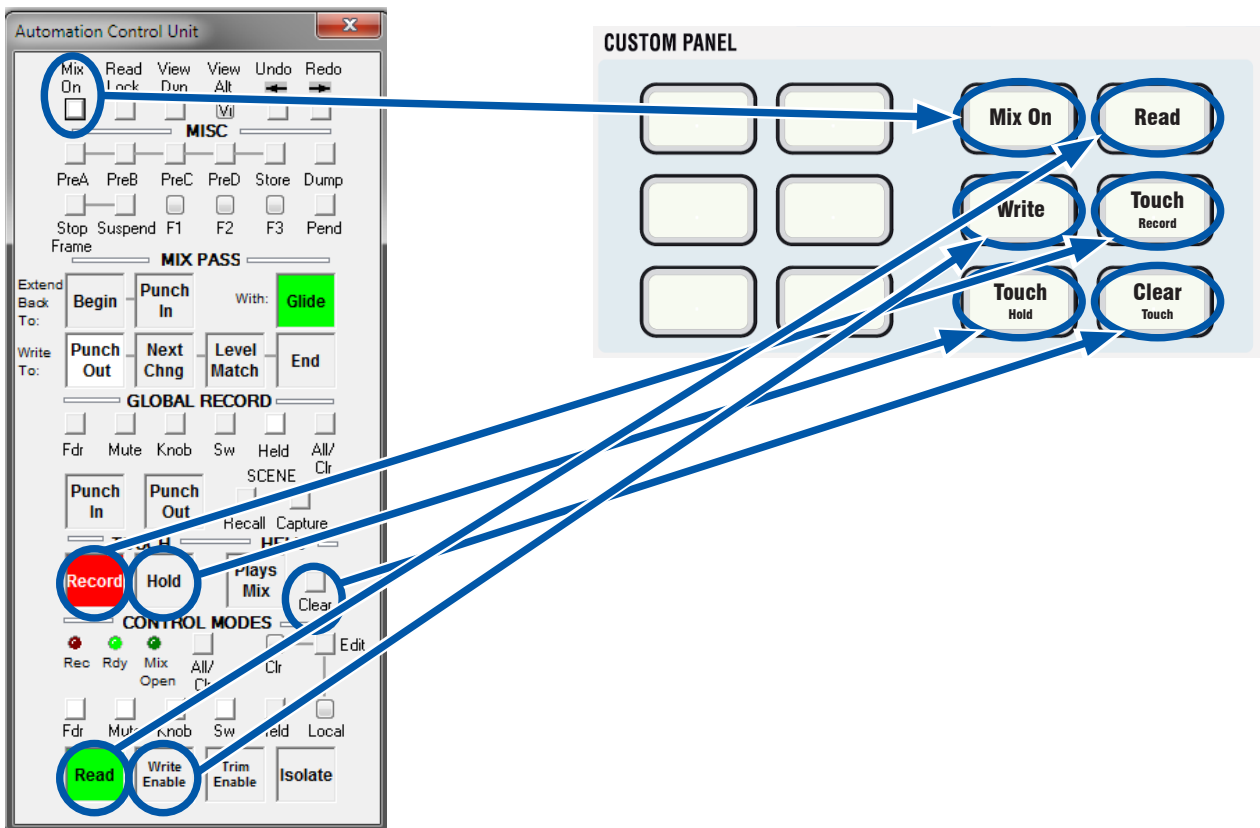

5.2.3 Mix Passes

Normally a new mix pass is automatically being created when play speed of incoming timecode is detected. A mix pass finishes upon detection of non-play speed.

In order to record slower than play speed (slow motion) or even write automation data between two locate points, it is necessary to start and stop a mix pass manually.

A mix pass is manually started by switching Stop Frame automation on by using the **Stop Frame** button. It is finished when this button is switched to off again.

Note: The automation cannot record backwards; it records data up to any incremented timecode value. Therefore it is not possible to erase data by going backwards using the transport buttons on the **Machine Control** window.

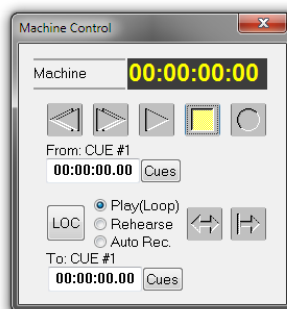

In order to locate precisely to a certain frame without ‘overshooting’, it might be useful to suspend the reading of timecode while searching for that specific frame. This can be done by activating the **Stop Frame – Suspend** button.

Example The user wants to write data between 1:00:01:00 and 1:00:09.20, using the transport buttons on the **Machine Control** window to locate both points precisely.

Procedure:

1. Find the starting point with the transport buttons.
2. Start a mix pass by switching **Stop Frame** on.
3. Punch-in requested objects.
4. Activate **TC OFF**.
5. Locate the end point 1:00:09:20 using the transport buttons (the user can freely ‘jog’ around this point and even overshoot in order to locate precisely). It is possible to use locate commands as well.
6. Deactivate **TC OFF** ⇒ Automation data is written up to the current timecode value.
7. Finish the mix pass by switching **Stop Frame** off.

5.2.4 Write Zones

In order to protect any passages from being overwritten by automation data, it is possible to define a write zone in the graphical controller. If activated, it is not possible to write any data outside that zone. When working together with machine control (looping), it is possible to synchronize this write zone constantly with the set In and Out points of the machine control.

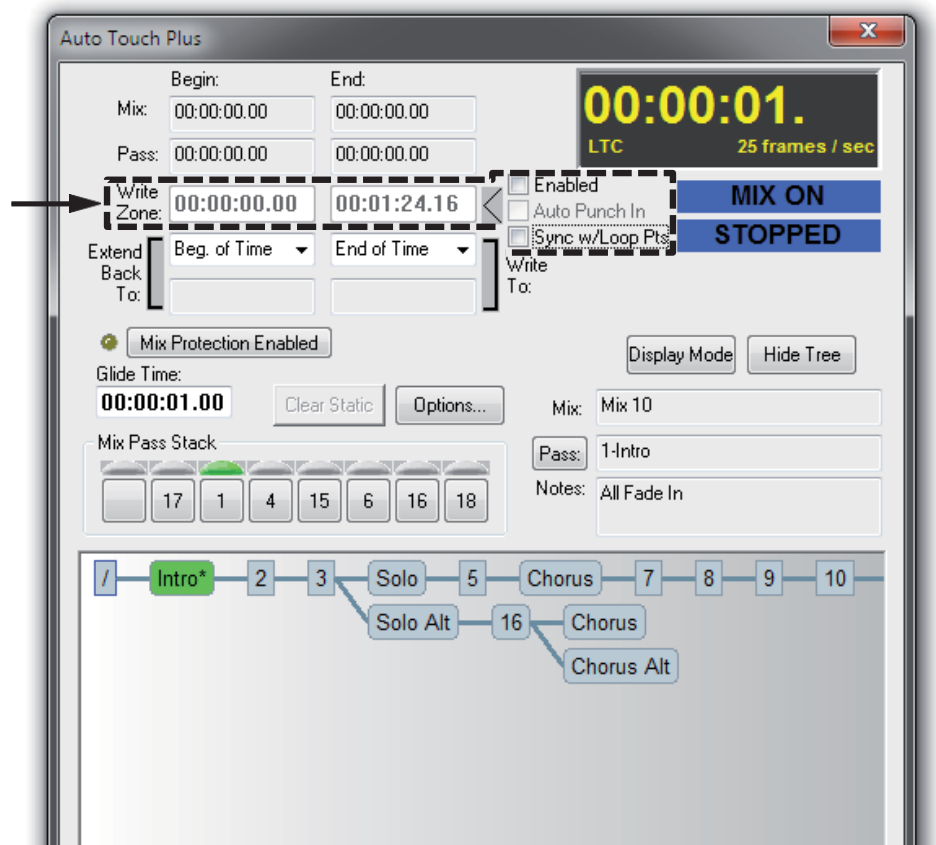

5.2.5 How to...

...put the whole console into write mode?

Activate preselector buttons Fdr, Mute, Knob, Sw (or click the All/Clr button) and click **CONTROL MODES – Write Enable** (make sure you have **TOUCH – Record** active in order to record any changes against timecode).

...put all faders into write mode?

Select **GLOBAL RECORD – Fdr** as preselector and click **Write Enable** underneath in order to put all faders into write mode (make sure you have **TOUCH Record** active in order to record any changes against timecode).

<Option>

There is an optional setting (see menu ‘Automation Options...’, ‘Control Modes’, ‘Mode Enable sets non-selected to READ’, also refer to [chapter 5.22.2](#)) which determines whether the non-selected functions (e.g. Mute, Knob, Sw) will change their state to READ or whether they don’t change their automation state when putting the faders into WRITE.

...put a group of faders into write mode?

Select **GLOBAL RECORD – Fdr** as preselector and create a gang of the channels that should change their automation mode to Write. Then toggle through the automation modes by pressing the **ISO (AUTO MODE)** key in any of the linked channels several times, until the automation state indication on the TFT says ‘**W**’ (make sure you have **TOUCH – Record** active in order to record any changes against timecode).

...use ‘Rehearse’ mode?

Basically you just have to switch off the **RECORD** button. This will prevent all upcoming touches from switching into recording. To rehearse some settings, you will normally have **HOLD** on, since you want your settings to stay when you physically un-touch an object. In this way you will see all objects you changed in order to rehearse some alternate settings indicating ‘held’ state, either by underlined values (Vistonics module) or in the fader case by the displayed dB values. You can now stop the tape, rewind, and all objects will stay ‘held’. Now you activate the **HOLD** button from the preselectors of the section **GLOBAL RECORD** (Punch In / Punch Out) and play the tape again. When you click the Punch In or Punch Out button, you will now put all your rehearsed objects in and out of recording.

Note

If objects are moved in rehearse mode, you will always hear what you see. However, if you want to switch over and hear the underlying original mix, simply activate the **HELD – Plays Mix** button.

...correct a mix pass and let the automation take over whenever the level matches?

Select Write To...: **Level Match**. Please note that these Write To... buttons will only affect automated objects *after* they are punched out. This is to prevent unwanted punch-outs while you are still touching an object and doing corrections. In order to move e.g. a fader manually over the point of level match and make it punch-out upon level match, you need to punch-out first and afterwards touch the fader again ‘without the automation detecting the touch’. This means you will have to hold down the **ISO (AUTO MODE)** modifier key when touching the fader again. Now you can move the fader towards the point of expected level match. As soon as this level is reached, this fader will stop recording.

There is also an alternate way of suppressing the detection of the touch: Switch **TOUCH – Record** off and then touch the fader, followed by a manual movement over the point of matching levels.

...activate a glide on one channel while another one shouldn't glide back?

As stated above, **Glide** is a mode button and does only influence upcoming punch-outs. You can switch this button while mixing.

E.g.: **Glide** is off and you punch-out channel 8. It will punch-out without gliding. Then you switch **Glide** on and punch-out channel 9. Since **Glide** mode is now activated, channel 9 will punch-out and glide back to the value of the last mix pass.

...keep an object in 'held' mode while another one should not be held?

There are two easy ways for this. The first one is similar to activating and deactivating **Glide**: Switch **TOUCH – Hold** on and physically un-touch an object – it will stay 'held'. Change the **TOUCH – Hold** state to off, and the next time you physically un-touch an object it will also come out of 'held' state.

A second way is to hold down the **ISO (AUTO MODE)** modifier key while releasing an object. This will invert the **TOUCH – Hold** state for that specific event.

Note The behavior of the modifier key can be defined in the automation options (Misc, Modified Un-touch Inverts) whether **TOUCH – Record** or **TOUCH – Hold** will be modified.

...make an object louder for the entire mix while keeping its movements?

In the Extend Back To.../Write To... sections, activate **BEGIN** and **END**. Select **Trim Enable** mode for the desired objects (section **CONTROL MODES**, use preselectors). Start a mix pass and move the desired objects by the amount you want them to be corrected.

In this case the movements of the objects will be kept, only the 'offset' will be written to the new mix pass.

Note When **Trim Enable** mode for **Fdr** is selected, the faders will jump to the 0 dB position and therefore indicate the correction level rather than the real fader values.

The real values will still be displayed in the touch-screen area. On rotary controls, Vista will display the amount of corrections in digits while displaying the real values graphically.

...erase all movements of an objects on the entire mix? Or, how to...**...turn a 'dynamic object' back into a 'static object' again?**

In the Extend Back To.../Write To... sections, activate **BEGIN** and **END**. Select **Write Enable** mode for the desired objects (section **CONTROL MODES**, use preselectors). Start a mix pass and set the desired objects to the value you want to have for the entire mix. This will write the level at the time of punch-out to the time between **END** and **BEGIN**.

Note The exact meaning of **END** and **BEGIN** can be defined on the graphical controller screen, but defaults to 'begin of mix' and 'end of mix'.

5.3 The Details

AutoTouchPlus provides a powerful and comprehensive automation system that is easy and efficient to use. All users will find the flexibility to work in the way most appropriate for the task at hand without overly complicated procedures. Users will also find the power to efficiently create and fine-tune the optimal mix.

AutoTouchPlus allows any control defined within a VMC file to be automated. This includes faders, encoders, switches, and bus assignments. Connections made within the new and improved General Patch, audio oriented objects in the Channel Patch, and select Graphical Controller (GC) menu items may also be automated.

5.3.1 About this Chapter

Assumptions This chapter is designed to explain the operation of the Studer AutoTouchPlus dynamic automation system. It will prepare the reader for basic to advanced operation of the system. It assumes the user will have basic familiarity and operational proficiency with the Vista consoles. The full understanding of many of the terms and concepts depends on this familiarity. Refer to the Console Operation chapters of this manual as necessary.

Redundant Information In several chapters information is repeated. This is to accommodate those who will use this document as a reference, only going to the chapter(s) in which help is needed. Redundant chapters will become obvious to those who will read this document as a text, and may be skipped as desired. This chapter is designed to provide information for both new as well as long-time Vista users. Basic information is sometimes presented and is not intended to offend advanced users.

5.3.2 Features

There is an impressive array of features built into AutoTouchPlus. A summary of these features follows.

Mix Management Automation Mix files are managed via the Mix Tree System (MTS). The MTS will work in conjunction with the expanded Mix Pass Stack (8 Mix Passes). Each and every Mix Pass will be automatically saved and archived within the Mix Tree. Multiple Mix Trees can be created within a Title. Any previous mix can become the Active Pass (or Read Mix Pass) for a subsequent Record Mix Pass. The MTS is maintained between sessions, so that when a mix is recalled days or weeks later, the entire Mix Tree will be available to the new session. The Mix Tree may also be hidden so that all mix management can be done within the Mix Pass Stack. At any time the Mix Tree may be made fully visible again. Mix Passes may be named and comments may be added. A full mix link history is maintained.

Static Objects When a mix is first created (when a Mix Tree is first opened) all automatable controls are Static Objects. Static objects act just like manual controls except that their final setting is remembered by the automation. All controls remain Static until a Dynamic move is recorded.

Any switch, fader or knob (automation objects) may be classified as a Static object. They may be adjusted at any time during the mix process without needing to put them into a **Write Enable** or **Record** automation mode (similar to mixing on an analog console). The value of all static objects is maintained on a pass-by-pass basis. This simplifies the ‘tweaking’ of the hundreds of controls within a mix session that must be adjusted, but will never change at timecode locations. Should a Dynamic move be required for a Static object, the move can be simply written into the mix, and the object is transformed automatically into a Dynamic automation object. This simple and effective system will greatly enhance the mix process and dramatically improve mix efficiency.

Independent Automation Modes Different channels may be in different automation Control Modes. For example some channels may be in **Write Enable** while others may be in **Trim Enable**. In addition, different controls (objects) within channels may be in different modes. For example the fader may be in **Trim Enable**, while the mute is in **Write Enable**, and the rotaries are in **Read**. Any combination is possible.

TOUCH – Record Function **TOUCH – Record** allows an enabled control to enter **Record** when touched. With **TOUCH – Record** turned off, a control be auditioned before it is punched-in to Record. With **TOUCH – Record** engaged, touching a Held-enabled control will permit an intentional ‘jump level’ punch-in if the Audition value is different from the **Read** Mix value.

TOUCH – Hold Function With **TOUCH – Hold** engaged, the setting of a touched control will be maintained when it is released. If **TOUCH – Record** was enabled before the control was touched, it will stay in **TOUCH – Record** upon release. **TOUCH – Hold** can function for faders, rotaries, and switches and can work in **Read**, **Write Enable**, and **Trim Enable** modes.

Held Plays Mix This feature allows the read mix to be heard, even though one or more objects are being held in an audition state awaiting a punch-in. This allows true emulation of the resultant mix, while the mix pass is being run.

| | |
|---------------------------------|--|
| Mix Pass Control | Full flexibility is allowed for how a new Mix Pass automatically merges with the Active Pass Read Mix data. The setting of a control when it is punched out may be written to the punch-out point; the next data change in the read mix; when a level match occurs (auto-takeover); or the end of the mix, the end of time (23:59:59:2x), or a fixed cue point. In addition, the setting at the punch-out point may be extended back to the punch-in point, the beginning of the mix, the beginning of time (00:00:00.00), of a fixed cue point. |
| Enhanced Glide Control | When the Glide function is active, every transition between the Read Mix data and the new pass will glide from one to the other according to the current glide time. In addition, some Glide transitions may be optionally set to 'back time' the glide so that they are completed at the desired edit point, rather than started there. Also, specific glide transitions may be suppressed while others are allowed. |
| Scene Capture | Any specific set of controls, their settings, and automation modes can be saved in the Scene buffer. This allows the exact settings of those controls to be punched into the mix at a later time when the scene occurs again. |
| Read Lock | This forces the automation system to playback the current Active Mix and ignore any and all key and control changes. This ensures a perfect audition playback or layback to the final master record machine. |
| Real Time Switch Editing | Switch data may be edited in real time allowing the movement of the in-point and or the out-point, as well as adding or deleting Mutes and Ins or Outs. |
| Event List Editor | All automation events may be edited (moved, copied, or deleted) offline using the Event List Editor. |
| Full Offline Editing | The OFLA (Off-Line Automation) application is integrated in AutoTouchPlus. Mix data comprising the entire mix, or any specified objects for any specified time range may be changed, merged, or copied with other mixes or itself. |
| Protection | Any set of controls may be placed in a protected status. Protected controls playback their recorded moves, but are prevented from being enabled for Write or Trim operations. This is useful for protecting channels or controls that have already been written, while working on other aspects of the mix. |
| Write Zone | A Write Zone may be specified so that no data can be written outside the time range specified. This is useful for working on a specific scene or section while protecting the rest of the mix from accidentally writing into it. This will also facilitate the automatic punch-out (with or without glide) at the end of the Write Zone. |
| Auto-Punch | When Auto-Punch is active the system will automatically punch Write Enabled controls into Record at the beginning of the Write Zone. |
| Stop Frame Automation | The Stop Frame automation feature makes it possible to write specific control values between timecode locations. The user can stop timecode playback at a specific location, set any number of controls to desired values, and move to the next location forward in time where values may again be adjusted. The initially set values will be recorded between the timecode locations. |

5.3.3 Operational Philosophy

The automation system follows the paradigm that there is audio under each control. It is as if this were a conventional analog moving fader system, in which case the fader position *always* represents the audio level. This is referred to as WYSIWYH ('What You See Is What You Hear'). However, in order to enhance the operation of the system, this rule is broken from time to time. Those cases will be noted and they are the exception. The general rule is WYSIWYH.

Formula Based System

In order to make a very powerful system that is also easy to understand, the system is based on a set of consistent Rules that pertain to the behavior of each mode or function. It is the consistency of these Rules, that allow the system to be simple to understand, yet very deep and powerful.

To these Rules, Conditions and Options may be imposed that further define the behavior of the basic modes or functions. It is these Conditions and Options that add extra facility and flexibility to the system.

Options essentially 'fine-tune' the functionality or operation of specific areas of the system.

The combination of Rules, Conditions, and Options allows the user to start using the system in a basic and easy to use manner. As familiarity increases (and based on the needs of the production), more complex operations may be carried out by applying the appropriate Conditions and/or Options. The system also provides extreme flexibility so operation may be essentially 'customized' to the task at hand and/or the working style of the user. The net result is a powerful and flexible automation system, that is easy to use, but can address even the most complex needs of any production.

Rules Rules define the basic behavior of a control, a function or a feature. The basic Rules are simple and straightforward. In the simplest form, these Rules will dictate the basic functionality of the system. In this regard, Rules mostly apply to the basic modes of operation, but it should be noted that all aspects of the system have their own set of rules.

In some cases the Rules will be broken or modified, and the exact function will be determined by a given set of Conditions and Options.

Conditions Conditions further define the behavior(s) of a control, function, or feature. They are imposed by the selection of combinations of modes/features and in some cases by way in which controls are operated. Conditions may be influenced by the selected set of Options.

Options Options apply operational or functional details to specific areas of the system. Options further define the behavior of the associated mode, control, feature, or function. In some cases, Options may influence the system independently of the Rules and Conditions being applied. Options are set by selecting the appropriate tab in the Mix Options page. They are indicated throughout this document within brackets, i.e. <Option>.

Operational Formula

The essential aspect to understanding the system is the following formula:
Rules + Conditions + Options = Exact Function

The key to efficient operation is knowledge of this formula and the elements within. Rules provide the basis of operation and functionality, Conditions further define behaviors, and Options provide specific parameters to the various elements being used.

In some instances (such as Switch and GC automation), the operation of the control will also influence its functionality. However, in the majority of cases the formula above will apply.

***Document Note** When appropriate, this document will organize information with the operational formula in mind.*

Functional Formula Three basic areas should be kept in mind when conducting most AutoTouch-Plus operations:

- Selected Control Mode: Basic operating modes (**Read, Write Enable, Trim Enable, and Isolate**). Refer to [chapter 5.7](#).
- Selected Touch and Hold Functions: Determine the effects of touching a touch-sensitive control or operating a switch. Refer to [chapter 5.8](#).
- Transition of data: How the data transitions between previously recorded data and newly recorded data. Refer to [chapter 5.10](#).

If these areas are considered, especially when learning the system, logical and predicted results will routine.

5.4 Essential Concepts

In addition to the various Rules, Conditions, and Options, there is a small set of ‘essential concepts’ that must be understood when operating AutoTouchPlus. An explanation of these concepts follows.

5.4.1 Static and Dynamic Objects

One of the primary tenants of the AutoTouchPlus system is the concept of Static and Dynamic controls. By definition, the value of a Static control is remembered by the system, but does not change during the course of a Mix Pass. Dynamic controls are defined by having one or more changes recorded at specific timecode locations within a Mix Pass.

Note The terms ‘objects’ and ‘controls’ may be used interchangeably.

5.4.1.1 Static Objects

The addition of Static (objects) controls allows mixes to be created in much the same way as mixes would be made on an analog console with fader/mute automation, but with the power to automate any audio control as needed (not just faders and mutes). Once set to the desired values, the vast majority of controls will not need to be automated. However during the course of a mix, the engineer may need to periodically adjust the settings of these controls (such as ‘tweaking’ an EQ). As with an analog console, the new values will be applied with the expectation that settings will be retained from Mix Pass to Mix Pass. In AutoTouchPlus, Static controls will perform in this manner and allows the user to work in a very familiar and intuitive fashion.

Static Objects A Static object is defined as any automatable control that has no dynamic changes recorded within the Mix Pass. Therefore, Static objects retain one value throughout a Mix Pass. Any switch, fader, rotary control and some GC items (automation objects) may be classified as a ‘Static object.’ Static objects act just like manual controls except that their final setting is remembered by the automation. They may be adjusted at any time during the mix process without needing to put them into a Write or Record automation mode or needing to update the Mix Snapshot. The value of all Static objects is maintained on a pass-by-pass basis. This simplifies the ‘tweaking’ of the hundreds of controls within a mix session that must be adjusted, but will never move against timecode.

All objects are Static until a dynamic move is recorded. Should a dynamic move be required for a static object, the move can be simply written into the mix, and the object is transformed automatically into a Dynamic automation object.

Note If a control is put into Isolate, it’s static value will not change. If changed while in Isolate, the control’s current value will be heard, but its Static value will not be updated in subsequent Mix Passes.

Changing Static Values When a new mix (Mix Tree) is first opened, the Static value for every control is stored in the first Mix Pass. The stored Static values will be the current

values of all controls at the time the new Mix Tree was created. This value will be retained in subsequent passes unless the Static value is changed.

Any time a control is adjusted (without being in Record), its Static value will change. In other words, Static values may be changed as long as **Record** is not engaged for the control.

Static Data Buffer Changed Static values are temporarily stored in the ‘Static Data Buffer.’ The next time a new Mix Pass is created (usually by recording a Dynamic change on another control), the contents of the Static Data Buffer will be stored in the new pass. The old Static values will be retained in the previous pass. The new values will be retained in any new Mix Passes made from the just created pass. The Static Data Buffer may be cleared by clicking the **Clear Static** button in the **AutoTouchPlus** window.

‘Clear Static’ Button The **Clear Static** button in the **AutoTouchPlus** window has two functions:

- When lit, the **Clear Static** button indicates there is information in the Static Data Buffer and there is a difference between the current Static values and those stored within the Active Mix Pass.
- Clicking the **Clear Static** button clears the values in the Static Data Buffer and restores those stored within the Active Mix Pass. Clearing the Static Data Buffer cannot be undone.

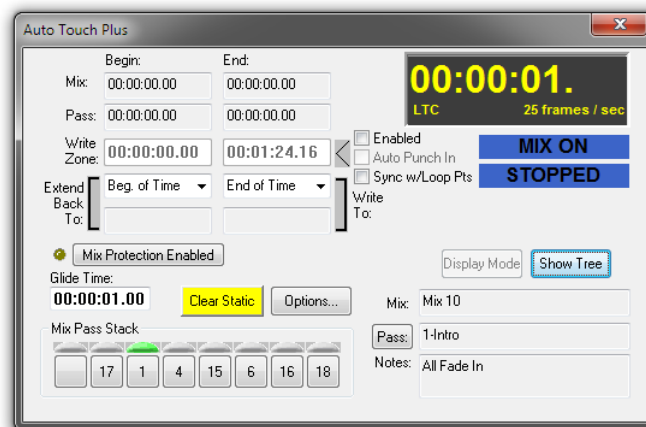

When the first Static object is changed within a Mix Pass, the **Clear Static** button illuminates. As mentioned above, this indicates that there is data in the Static Data Buffer. The values in the Static Data Buffer will be retained and the button will remain lit until one of two things occur:

- A new Mix Pass is created;
- The **Clear Static** button is clicked.

Note Static values can only be cleared on a global basis and cannot be cleared individually.

When a new Mix Pass is created, the current Static values are written to the new pass and the Static Data Buffer clears. When the Static Data Buffer is cleared with the **Clear Static** button, the temporary Static values are erased and the Static values stored in the current pass (Active Pass) are restored. In either case the **Clear Static** button goes out.

<Option> In the Automation Options... menu, item Misc (also refer to [chapter 5.22.7](#)), static objects can be protected under certain circumstances.

5.4.1.2 Dynamic Objects

A Dynamic object is defined as any automatable control whose value changes at one or more timecode locations within a Mix Pass. Any switch, fader, rotary control, and some GC items (automation objects) may be classified as a 'Dynamic object'. All moves applied to a Dynamic object are remembered by the automation and replayed at the corresponding timecode location.

Dynamic controls may be adjusted at any time during the mix process and recorded to a new Mix Pass using **Write Enable** or **Trim Enable** automation modes. In this way, the value of selected Dynamic objects is updated from pass to pass. Dynamic controls may also be Auditioned and/or 'pre-set' before a punch-in.

All objects will remain static until a move is recorded. Once a move is recorded, the object becomes a dynamic control. A dynamic control may be made static by erasing all recorded moves for that control for the entire pass.

The majority of this document discusses the automation of Dynamic controls.

View Clicking **View Dyn** will cause the lights for all dynamic controls currently on the desk to illuminate. This provides a very quick and easy means of identifying dynamic controls.

5.4.1.3 Mix Snapshot

The Mix Snapshot contains two types of data:

- The values for Static objects.
- The initial values for Dynamic objects from the beginning of the Mix Pass up to the first recorded change.

Every Mix Pass has a Mix Snapshot. When a Mix Tree is first opened, a Mix Pass is created that contains a Mix Snapshot with a Static value for each control. The Static value stored in the Mix Snapshot is the current value of the control at the time the Mix Tree was first opened. As a mix progresses the following operations occur:

- Changes to Static values are written directly to the Mix Snapshot each time a new Mix Pass is created.
- Changes made to Dynamic objects are written to timestamps (timecode locations) within the Mix Pass.

When changes are made to Static Objects, the Mix Snapshot is automatically updated when the next Mix Pass is generated.

The Mix Snapshot for Dynamic objects may be updated in two ways:

- Using the **Extend Back To: Begin** Mix Pass function. The value of the control at the time of a punch-out will be written back to the beginning of the Mix Pass (essentially updating the Mix Snapshot).
- Performing an 'Update Mix Snap' edit using the OFLA offline mix editor.

In normal operation, use of the Mix Snapshot is mostly transparent to the user and there is no need for manual updates.

5.4.2 Touch & Un-Touch Events

Another crucial but easy to understand concept is that of Touch and Un-touch. AutoTouchPlus is a very tactile system and relies on physical actions for efficient operation. Faders and encoders are touch-sensitive and can be made to respond in different ways depending on the mode and operation being performed. Switches and automatable GC items are not sensitive to physical touch, but their actuation can generate similar messages as faders and encoders.

Touch Events The physical touching of a fader or encoder produces a 'Touch Event'. Actuating an automatable switch or GC item may also generate a Touch Event, depending on the current mode.

Un-touch Events The physical release of a fader or encoder produces an 'Un-touch Event'. Automatable switches and GC items may also generate an Un-touch Event, depending on the current mode.

Events and AutoTouchPlus In most cases, Events come in Touch and Un-touch pairs... that is, a Touch followed by an Un-touch. An example would be touching a fader, moving it for a short period of time, and then releasing it. When the fader was first touched, a Touch Event will be sent and when released an Un-touch will be sent. AutoTouchPlus will either use both Events, ignore both Events, or suppress one or the other. Details of how these events are used and the operations this makes possible are discussed throughout this document.

5.5 File Management

Mix File Structure There may be multiple mixes within each Title. Each Mix has its own name and a folder in which its files are kept. There is one Mix Tree for each Mix. A Mix Tree is a collection of Mix Passes, along with a Mix Tree file. Each Mix Tree and its files are kept in the Mix Folder. This really eliminates clutter within the Title folder because no matter how many Mix Passes are stored, they are all within their own separate folder.

Mix File Organization The files and folders created and used by AutoTouchPlus are identified as follows:

- The Mix tree database file has an .mt extension (filename.mt);
- Each Mix Pass ends in the pass number with a .mix extension (file-name-004.mix);
- The folder that the mix tree file and mix pass files resides in is the name of the mix (filename).

The following example shows the file structure for a Mix named ‘Baby Blues’:

D950Projects (Main projects folder)
 ---**Mixdown July** (Project folder)
 ----**Album E** (Title folder)
 -----**Song 04** (Mix folder)
 -----**Song 04.mt** (Mix tree)
 -----**Song 04-001.mix** (Mix passes)
 -----**Song 04-002.mix**
 -----**Song 04-003.mix**
 -----**Song 04-004.mix**
 -----**Song 04-005.mix**
 etc.

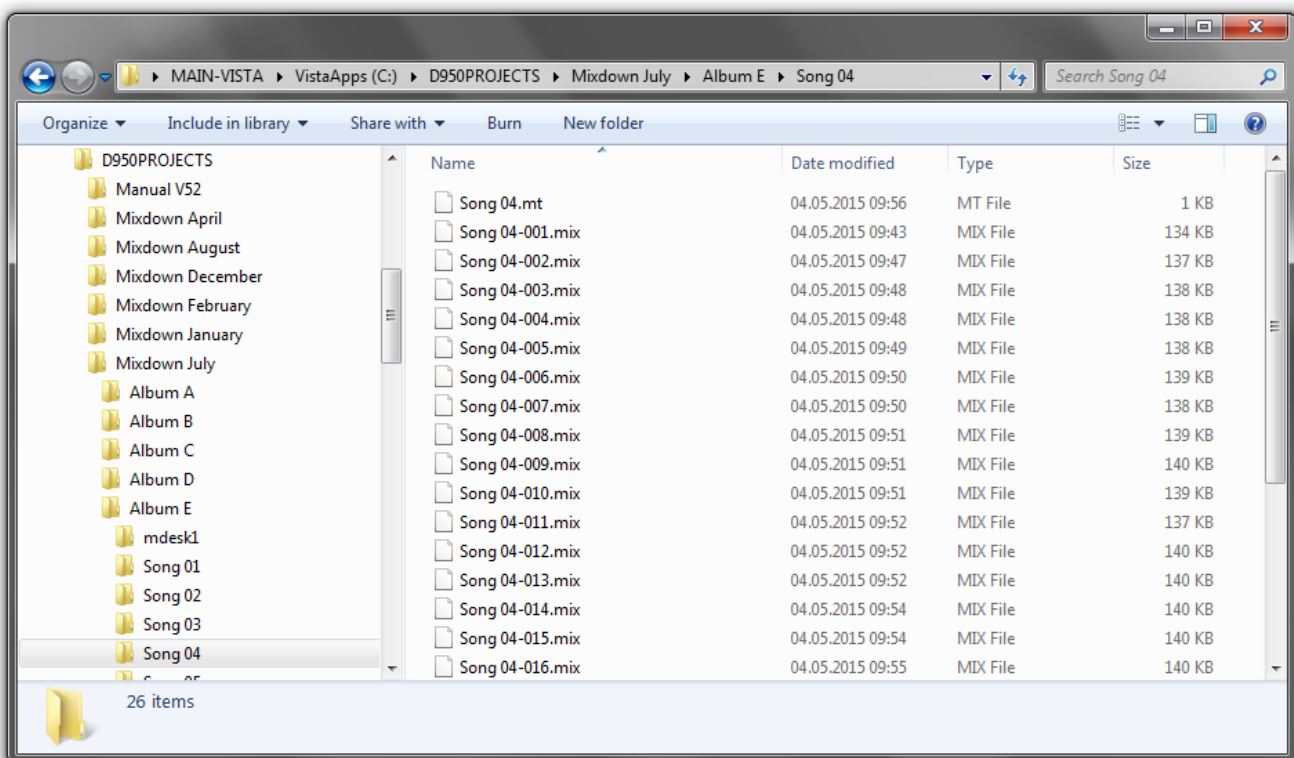

5.5.1 Mix Tree

Automation Mix files are managed via the Mix Tree System (MTS). Each and every Mix Pass is automatically saved and archived within the Mix Tree.

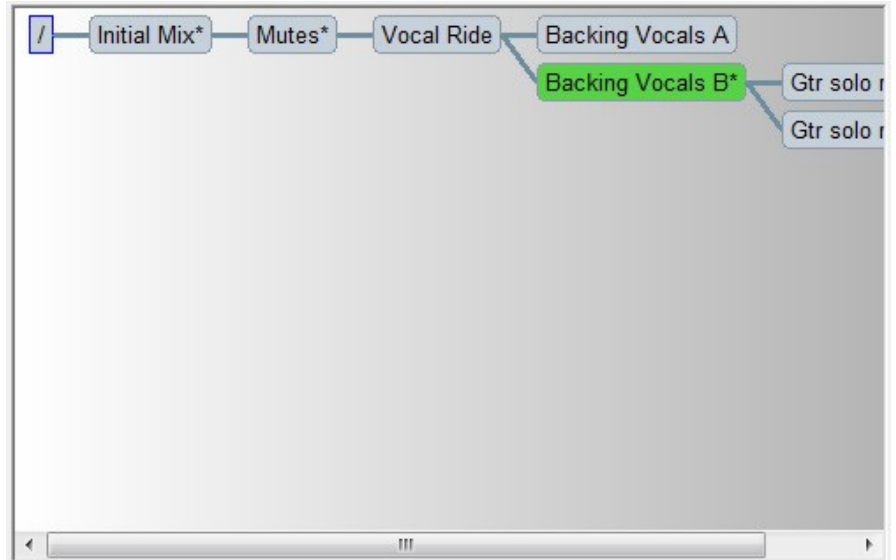

Used in a linear fashion, the Mix Tree will have no branches. If at some point a previously written Mix Pass becomes the Active Pass, a new branch of the Mix Tree will start growing as new passes are generated. In this way, the Mix Tree provides a graphic representation of the evolution of all Mix Passes. See above.

Each Mix Pass is displayed as well as its linked history (the branch of the Mix Tree from which the pass evolved). Working in conjunction with the Mix Pass Stack, the Mix Tree provides an efficient means of organizing the multiple Mix Passes that are created during the course of a mix. This is particularly useful when creating several final versions of a mix.

The MTS is maintained between sessions, so that when a Mix is recalled days or weeks later, the entire Mix Tree will be available to the new session. All Mix Passes will be recalled and placed in their proper positions when the Mix Tree is opened. The last Active Pass used will be loaded to the top of the Mix Pass Stack and becomes the Active Pass. (The Mix Pass Stack is not maintained when the Mix Tree is closed.)

Any number of new Mix Passes may be generated. Any existing Mix Pass from any Title may be added to the Mix Tree.

5.5.1.1 Passes in the Mix Tree

- Mix Pass Info** Each completed Mix Pass has the following information:
- Assigned Mix Pass Number
 - Mix Pass Name
 - Mix Pass Notes

Mix: Song 01

Pass: 3-Vocal Ride

Notes:

- Assigned Mix Pass Numbers** Assigned Mix Pass Numbers are used by the system to identify each Mix Pass. For example, a Mix Pass is identified only by its number when it's part of the Mix Pass Stack.

As Mix Passes are added to the Mix Tree, an Pass Number is automatically assigned to each. Mix Pass numbers are assigned in the order in which passes were added to the Mix Tree. For a new Mix Pass, the assigned number will serve as a temporary Mix Pass Name unless a new one is entered. For an existing Mix Pass, the assigned number will be displayed before the stored pass name as it appears in the Mix Tree.

- Mix Pass Names** As mentioned above, the assigned Mix Number will serve as a temporary Mix Pass Name for new Mix Pass. This name will persist until the current Mix Tree or Title is closed (or a new Mix Tree or Title is opened). If no name is entered, the assigned pass number will appear as the Mix Pass Name in the Mix Tree. The resultant stored file name will be the name of the Mix Tree and pass. For example, if a name is not entered, 'Dulcimer-002.mix' would become the stored file name for the second Mix Pass in the Mix Tree named 'Dulcimer.' The next time this Mix Tree is opened, this Mix Pass would appear as the second Mix Pass in the Mix Tree and have the pass name '2.' If this same Mix Pass was loaded in another Mix Tree, it would appear as 'Dulcimer_Pass_002' with the number of its position within the current Mix Tree.

- Editing Mix Pass Name** A Mix Pass must be the Active Mix Pass before it's name can be entered or edited. To enter or change a Mix Pass Name, use the following procedure:
1. Make the Mix Pass to be named or renamed the Active Mix Pass by clicking its icon in the Mix Pass Stack or double-clicking its icon in the Mix Tree.
 2. Click the 'Pass:' button next to the current Mix Pass Name (to the right of the Mix Pass Stack). The Pass Info entry box will appear with the Pass Name highlighted.

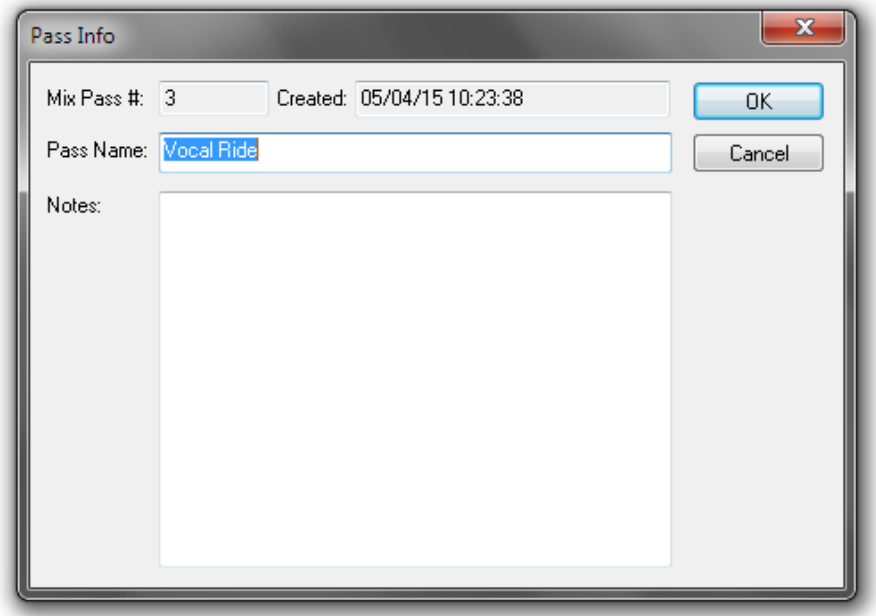

3. Type the new name for the pass and click **OK**. The new Mix Pass Name will appear in the Pass Name field and in the Mix Tree.

Mix Pass Notes A set of notes can be entered and stored for each Mix Pass. Combined with the Mix Pass Name, this can greatly benefit the organization of a large number of passes.

Editing Mix Pass Notes A Mix Pass must be the Active Mix Pass before notes can be entered or edited. To enter or change Mix Pass Notes, use the following procedure:

1. Make the desired Mix Pass the Active Pass if it is not already. (Click its icon in the Mix Pass Stack or double-click its icon in the Mix Tree.)
2. Click the 'Pass:' button next to the current Mix Pass Name (to the right of the Mix Pass Stack). The Pass Info entry box will appear. See #2 above.
3. Type the new notes in the 'Notes:' field and click **OK**. The first few lines of the new Mix Pass Notes will appear in the AutoTouchPlus window whenever that Mix Pass becomes active. If the notes are lengthy, the complete set may be viewed by opening the Pass Info entry box.

5.5.1.2 Active Pass

The Active Mix Pass provides the Read Mix data for subsequent Record Mix Passes.

When a Mix Pass becomes Active the following events occur:

- In the AutoTouchPlus window:
 - The name and assigned number of the Mix Pass appears in the **Pass:** field
 - The name of the Mix Tree appears in the **Mix:** field
 - Any notes belonging to the pass appears in the **Notes:** field
 - The Green Light illuminates above the associated position in the Mix Pass Stack
- In the Mix Tree window:
 - The Mix Pass is highlighted in green



The Active Mix is normally the mix on the top of the stack. Refer to [chapter 5.6.1](#) for details regarding the Mix Pass Stack.

5.5.1.3 Mix Tree Display Modes

‘Hide Tree’/‘Show Tree’ Button

AutoTouchPlus may be operated with or without the Mix Tree displayed. The Mix Pass Stack will be available in either case and can be used without the Mix Tree if desired (as in V2.5). To facilitate working without the Mix Tree, it may be hidden so that all Mix management can be done within the Mix Pass Stack. The Mix Tree is hidden by clicking the **Hide Tree** button in the AutoTouchPlus window.



The Mix Tree will disappear as indicated below and the **Hide Tree** button changes to **Show Tree**. At any time, the Mix Tree may be made fully visible again by clicking the **Show Tree** button.

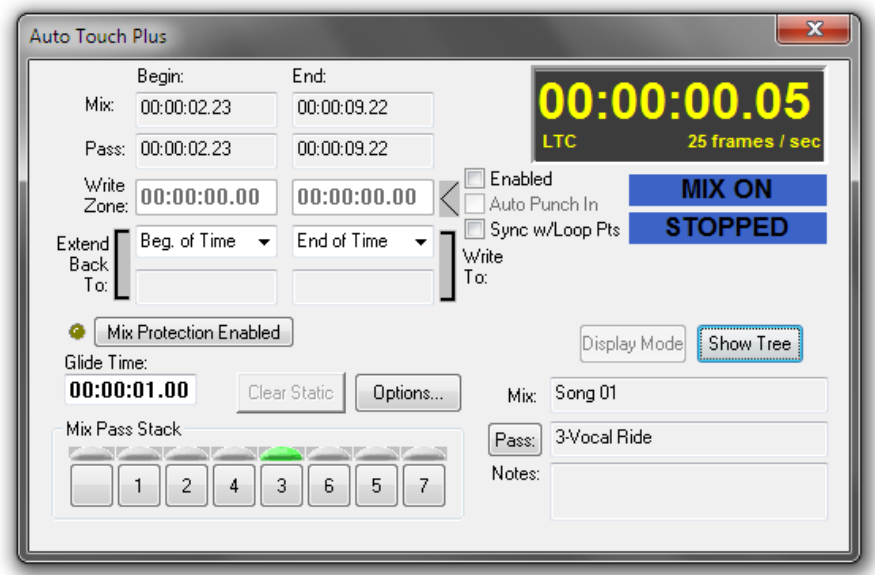

Whether or not the Mix tree window is displayed, the Mix Pass number, name, and notes are always displayed for the currently selected Active Mix. See above.

Mix Pass Display Modes

Within the Mix Tree, Mix Passes are displayed in one of three ways:

- Pass Name:

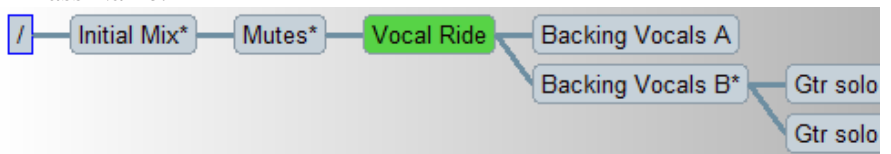

- Pass Number:

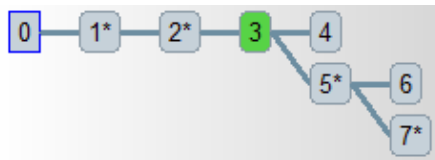

- Pass Name and Number:

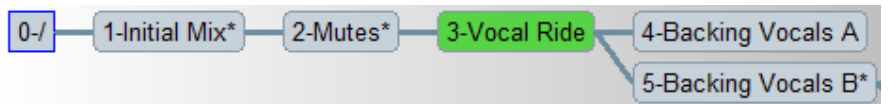

Changing the Display Mode

There are two methods to change the Mix Pass display modes:

- Display Mode button: Clicking the Display Mode button will cycle through the three display modes. The Display Mode button is located in the AutoTouchPlus window.

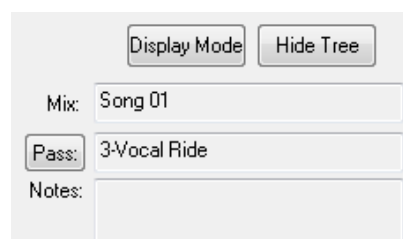

- **Display Options menu:** Right-clicking within the Mix Tree window will bring up the Mix Tree menu. Selecting **Display Options** from this menu will open a context menu which contains the three display modes. The desired mode can be selected from this menu.

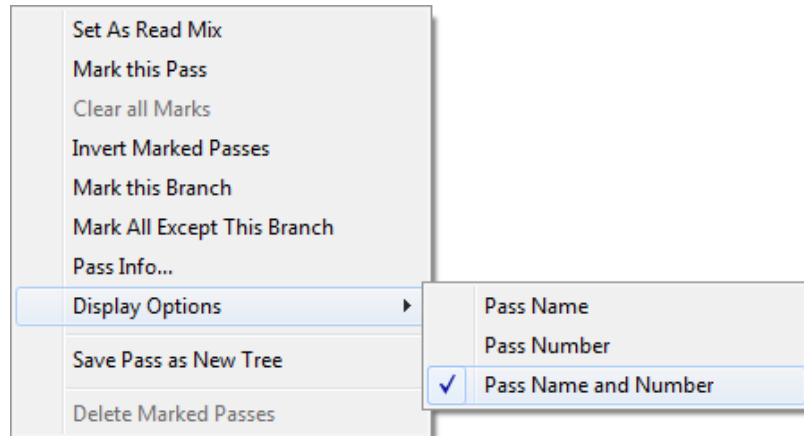

Notes Until a Pass Name is entered, the name defaults to the pass number. The system detects this and when the display mode is set to display the name AND number, if they match, only the number is displayed. The Mix Pass number, name, and notes for the Active Mix are always displayed in the AutoTouchPlus window.

Round and Square Corners Mix Passes within the Mix Tree have either rounded or squared corners. Rounded corners indicate the Mix Pass is part of the Mix Pass Stack. Squared corners indicates it is not. See graphic below.

Green Highlight The Active Mix Pass is highlighted in green in the Mix Tree and by a green LED symbol in the Mix Pass Stack.

Asterisk An asterisk will appear in the Mix Tree icons for all Mix Passes that contain Mix Pass Notes. This condition will persist regardless of the chosen Display mode, see the graphic below.

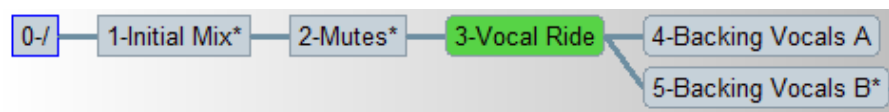

5.5.1.4 Mix Tree Click Functions

A variety of ‘click functions’ are available within the Mix Tree. These functions range from

- Left-Click Functions**
- Single-clicking a Mix Pass within the Mix Tree will ‘mark’ that pass by highlighting it in red. Clicking a marked pass will ‘unmark’ it and remove the red highlight. Only one mix at a time may be selected using this method.
 - Control-clicking (holding the **Ctrl** key and single-clicking) allows individual Mix Passes anywhere within the Mix Tree to be marked or unmarked. Any combination of passes may be marked.
 - Shift-clicking (holding the **Shift** key and single-clicking) two Mix Passes allows these passes and those in-between to be marked or unmarked. The passes must be within the same branch or root-branch of the Mix Tree. In this way, multiple passes may be marked. More importantly, the link history of these passes is maintained.
 - Double-clicking a Mix Pass adds it to the top of the Mix Pass Stack and makes it the Active Pass. The Active Pass will be highlighted in green in the Mix Tree.
- Right-Click Functions**
- Right-clicking within the Mix Tree will open the Mix Tree Menu. Only the items that do not pertain to individual passes or branches are shown.

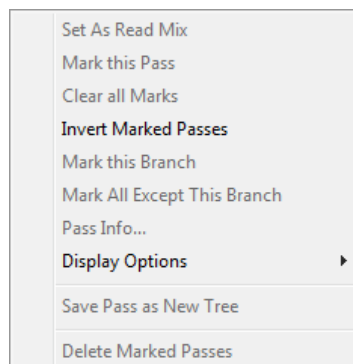

- Right-clicking a Mix Pass within the Mix Tree will open the Mix Tree Menu with all available items shown.

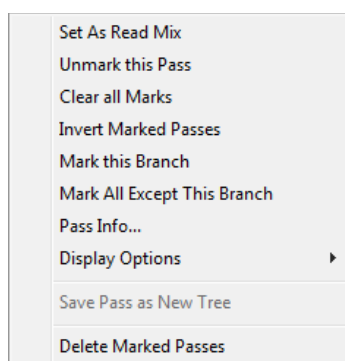

The **Mix Tree** menu items function as follows:

- **Set As Read Mix:** Makes the selected Mix Pass the Active Pass (this is the same as double-clicking a Mix Pass in the Mix Tree)
- **Unmark This Pass:** Unmarks the selected Mix Pass
- **Clears All Marks:** Unmarks all marked Mix Passes (always available when any passes are marked)
- **Invert Marked Passes:** Reverses which Mix Passes are marked and which are unmarked. (always available)
- **Mark This Branch:** The selected Mix Pass and all subsequent passes made from this pass will be marked
- **Mark All Except This Branch:** All branches except the one in which the selected Mix Pass is a member will be marked. Selecting a Mix Pass in the middle of a branch will prevent any member of that branch from being marked whether they were made before or after the selected pass. All other branches will be marked.
- **Pass Info...:** Opens the Pass Info entry box for the selected Mix Pass. The selected pass does not need to be the Active Pass in order to open the Pass Info entry box in this way.
- **Display Options:** Opens the context menu for Mix Tree Display modes. Name, Number, and Name & Number may be selected. (always available)
- **Save Pass As New Tree:** Creates a new Mix Tree with the selected Mix Pass loaded as the first pass. This function is only available for the Active Pass. The newly created Mix Tree will not automatically open, but may be opened as needed.
- **Delete Marked Passes:** Any marked passes will be deleted. Because this action is not undoable, the user will be prompted to verify this action.

5.5.2 Creating a New Mix

New Mixes To create a new Mix use the following procedure:

1. Select New Mix Tree... from the Automation menu in the GC.

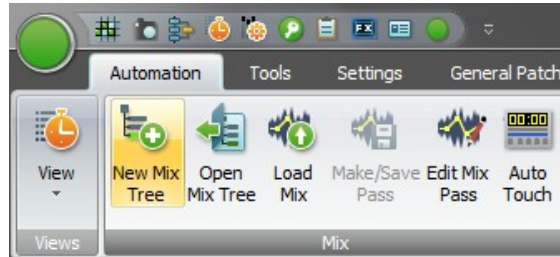

The New Mix Tree box will open and a display of existing Mixes will be shown.

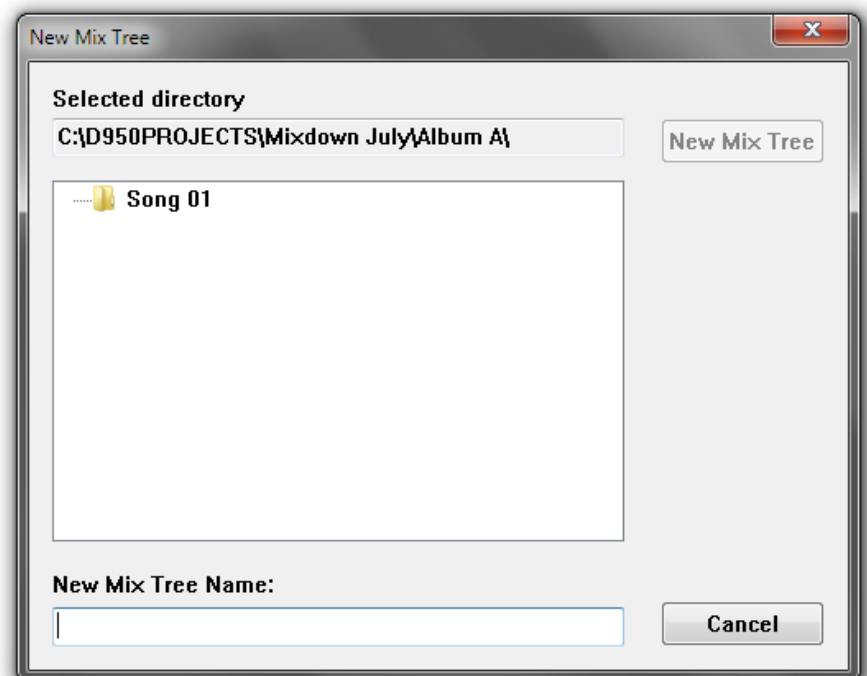

2. Enter a name for the Mix in the New Mix Tree Name: entry field. *Please note that the selected directory is given by the opened Project and Title and cannot be edited.*
3. Click the New Mix Tree button. A new Mix folder, Mix Tree file, and first Mix Pass file will be created in the Title folder.

A new Mix Tree will appear on the screen underneath the AutoTouchPlus window. A Mix Pass (#1) will be at the start of the tree and will be the Active Pass in the Mix Pass Stack.

5.5.3 Loading an Existing Mix

Existing Mix Trees and Mix Passes made with software V3.0 or later may be loaded by selecting the following from the Automation menu:

- **Open Mix Tree...**: Loads an entire Mix Tree. A directory of existing Mix Trees within the current Title will be displayed.

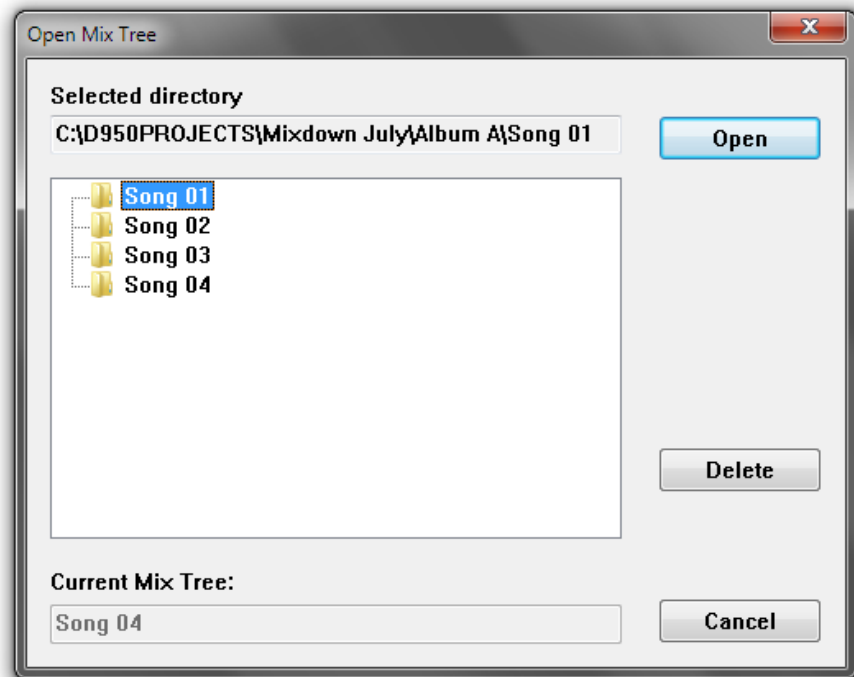

Double-clicking the desired Mix Tree (or selecting it and clicking Open) will load that tree. The last used Mix Pass will be loaded in the top position of the Mix Pass Stack and becomes the Active Mix.

- **Load Mix...**: Loads a single Mix Pass into the current Mix Tree. A directory of existing Mix Trees within the current Title will be displayed.

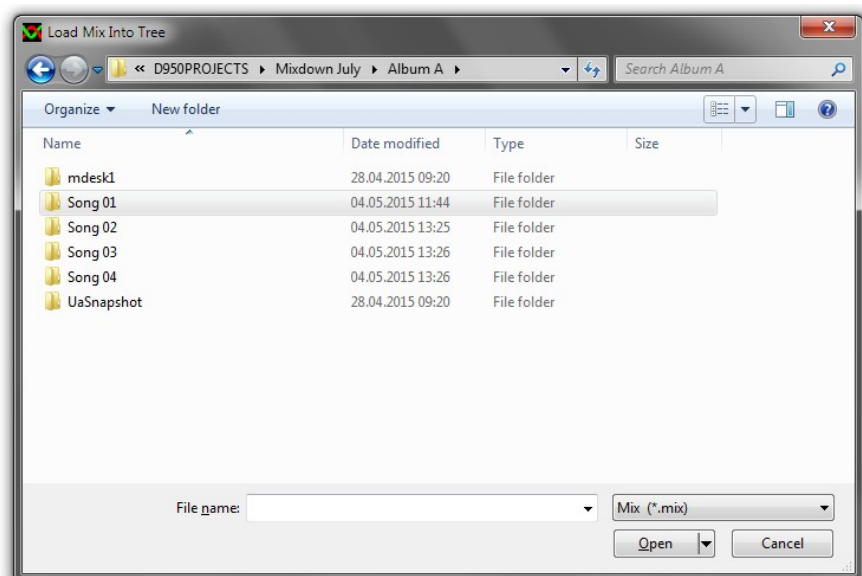

Double-clicking the desired Mix Tree folder will open that tree and the Mix Passes within will be displayed. The desired Mix Pass may be loaded by double-clicking its name or icon. The newly loaded Mix Pass will be loaded in the top position of the Mix Pass Stack and becomes the Active Mix. Mixes may also be loaded from other Titles.

Use the Import function (menu **File – Import – Mix**), select the Mix Pass in the desired Project/Title/Mix Tree, and click Open.

Now you can select the Project/Title/Mix Tree folder to save the selected Mix Pass. It is even possible to rename the Mix Pass if required.

Use the Load Mix function to load the Mix Pass into the current Mix Tree.

- Notes** Whenever a single Mix Pass is loaded, it starts a new branch at the start of the Mix Tree.
- The Mix Pass Stack is not maintained after the Mix Tree is closed. However, the last Active Mix Pass is loaded at the top of the Mix Pass Stack when an existing Mix Tree is opened.

5.6 Mix Pass

A Mix Pass contains a set of records for each dynamic control, fader Trim Replay Data if any, and a set of values for static controls.

- Creating a Mix Pass** A new Mix Pass is created whenever any of the following occur:
- A change in a dynamic control is recorded (such as using **TOUCH – Record** or Global Punch-in/Out);
 - **Make/Save Pass** is selected from the GC Automation menu;
 - An offline edit is performed with either OFLA or the Event Editor

In all cases above, the new Mix Pass is added to the Mix Tree and to the top of the Mix Pass Stack. It also becomes the Active Mix Pass.

As part of the Mix Tree, each new Mix Pass is stored to the hard drive. Because of this, every Mix Pass created is retained by the system unless purposely deleted. Refer to [chapter 5.5](#), File Management.

- Notes** Mix Tree folders or Mix Passes need to be deleted in the Windows Explorer. Making changes to Static controls or using Audition modes will not generate a new Mix Pass.

5.6.1 Mix Pass Stack

There is an eight-position Mix Pass Stack which holds up to eight Mix Passes in memory for immediate use. Mix Passes can only be played back from the Mix Pass Stack. The Mix Pass Stack is located in the AutoTouchPlus window on the GC.



Organization The eight positions of the Mix Pass Stack are represented by eight Mix Pass boxes arranged horizontally. The number of the Mix Pass will appear within the Mix Stack position (box) in which it is stored. A Mix Pass can appear only once within the Mix Pass Stack.

The box the furthest to the right is the position where Mix Passes are added to the stack. As Mix Passes are added, any existing passes shift to the left. When the Mix Pass Stack is full and a new pass is added, the Mix Pass in the last position (far left position) will be deleted from the stack as one to its right is shifted down.

In the example above, only three Mix Passes are loaded into the Mix Pass Stack and the #5 pass is Active.

Adding a Pass to the Stack Mix Passes are added to the Mix Pass Stack in the following ways:

- Creating a new Mix Pass: The newly created Mix Pass will be added to the top of the Mix Pass Stack and becomes active. See ‘Creating a New Mix Pass’ above.
- Double-clicking a Mix Pass in the Mix Tree: The selected Mix Pass will be added to the top of the Mix Pass Stack and becomes active.
- Right-clicking a Mix Pass in the Mix Tree: The Mix Tree Right Click menu will open. Selecting **Set As Read Mix** will cause the selected Mix Pass to be added to the top of the Mix Pass Stack and become active.

Active Mix Pass The ‘Active Mix Pass’ is the one played back and will be the basis for a new Mix Pass if any changes are made. It contains the ‘Read Mix Data’ that is used as new passes are created. The Active Mix Pass is indicated by a green light above the active position and the box containing the pass number is highlighted.

The Active Mix Pass may also be referred to as the Active Pass or Read Mix Pass.

Selecting an Active Mix Pass The Active Mix Pass is selected from the Mix Pass Stack in one of three ways:

- Clicking a Mix Pass in the Mix Pass Stack: That Mix Pass will become active.
- Double-clicking a Mix Pass in the Mix Tree: If that Mix Pass is already in the Mix Pass Stack it will become active. If it is not already in the stack, the selected Mix Pass will be added to the top of the Mix Pass Stack and becomes active.

- Creating a new Mix Pass: The newly created Mix Pass will be added to the top of the Mix Pass Stack and becomes active.
- Right-clicking a Mix Pass in the Mix Tree: The Mix Tree Right Click menu will open. Selecting ‘Set As Read Mix’ will cause the selected Mix Pass to be added to the top of the Mix Pass Stack and become active.

Conditions The Active Mix Pass cannot be changed while RECORD is engaged.

5.6.1.1 Mix Comparison

One of the unique features of AutoTouchPlus is the ability to compare Mix Passes while the mix is running. Any Mix Pass in the Mix Pass Stack can be accessed at any time, even while a mix is being played back.

Comparing Mix Passes

Mix Pass comparisons can be performed in one of two ways:

- Clicking a Mix Pass in the Mix Pass Stack: The clicked Mix Pass will become active after a short processing delay. Using this method, passes in the Mix Pass Stack can be activated in any order.
- Undo/Redo buttons: The Undo/Redo buttons activate adjacent Mix Passes in the Mix Pass Stack (see below).

Conditions Mix comparison is disabled once Record has been entered.

Note

A fair amount of processing must take place when switching between Mix Passes. Due to the time it takes to perform this processing a slight delay is normal.

5.6.1.2 Undo/Redo

Undo and Redo buttons are located in the top row of the ACU Window. They allow the user to essentially ‘undo’ and ‘redo’ changes as they are made within the course of a mix. They also provide a method for real-time mix comparison.



Undo and Redo

Using these buttons activates adjacent Mix Passes within the Mix Pass Stack, with **Undo** moving backward through the stack and **REDO** moving forward.

Note The **Undo** and **Redo** buttons move consecutively through the Mix Pass Stack. The order of passes heard while using the **Undo** and **Redo** buttons may not necessarily be in numeric order, depending on the order in which passes were added to the stack.

Undo / Redo The precise functions of the **Undo** and **Redo** buttons are as follows:

- **Undo:** Clicking the **Undo** button will activate the most previous Mix Pass in the Mix Pass Stack from the currently active position. In other words, clicking **Undo** will allow the previous adjacent Mix Pass to be activated.
- **Redo:** Clicking the **Redo** button will activate the next Mix Pass in the Mix Pass Stack from the currently active position. In other words, clicking **Redo** will allow the next adjacent Mix Pass to be activated.

Consecutive clicks of either button will continue through the Mix Pass Stack in the direction the button indicates (**Undo** = backward or to the left, **Redo** = forward or to the right). If the first pass in the Mix Pass Stack is the Active Pass, the system provides eight levels of undo/redo.

Conditions **Undo** and **Redo** are disabled once **RECORD** has been entered.

Notes Since all Mix Passes are stored in the Mix Tree, it is always possible to retrieve any Mix Pass at anytime. However, passes must be in the Mix Pass Stack to be played. In addition, the **Undo** and **Redo** buttons do not apply to the Mix Tree and activate only the passes in the Mix Pass Stack. The **Undo** and **Redo** buttons only allow activation of adjacent passes within the Mix Pass Stack. The order of passes may or may not follow the branches of the Mix Tree. This is depending on the order in which Mix Passes were added to the Mix Pass Stack.

Using Undo and Redo

- **Discarding an Undesired Pass:** If a new Mix Pass was just completed, the new pass will be at the top of the stack and will become active. If it contains unsuccessful moves, going back to the previous pass is as easy as clicking **Undo**. When **Undo** is clicked, the previous Mix Pass will become active and therefore the basis for the next new pass. In this regard, consecutive clicks of **Undo** will allow the user to 'back up' to a Mix Pass that provides a suitable point from which to restart.
- **Real-time Mix Comparison:** Clicking **Undo / Redo** while a Mix Pass is being replayed, adjacent passes in the Mix Pass Stack may be compared in real-time.

5.6.1.3 Dump

The **Dump** function prevents a new pass from being written if flaws are detected while a new Mix Pass is being created. This is useful if a mistake is made during a Record pass and the resultant pass would not be worth keeping.

The **Dump** button is located next to the **Undo / Redo** buttons in the ACU window.

Dumping a Mix Pass If **Dump** is engaged when timecode is stopped, the new mix pass will not be written. To prevent a new Mix Pass from being written, click the **Dump** button *before* playback of timecode stops.

Note **Dump** may be engaged and disengaged at any time while timecode is being played back. This allows the user to kill a pass and then change his or her mind before the timecode is stopped. As long as timecode hasn't stopped, Kill pass may be toggled on an off at will. The Kill Pass state that exists when timecode is stopped will dictate the fate of the Record Mix Pass

Dump will always disengage at the end of a Mix Pass.

Conditions Dump functions only when Record passes are in progress.

<Option>

- With <Protect Static From Kill Pass> checked in the Misc Options page, changes made to Static controls are retained when **Dump** is used; also refer to [chapter 5.22.7](#).

Note The Mix Options window is opened by clicking the 'Options...' button in the AutoTouchPlus window. Clicking the appropriate Tab will open the corresponding page.

5.7 Control Modes



There are four Control Modes used in the AutoTouchPlus mix system:

- **Read**
- **Write Enable**
- **Trim Enable**
- **Isolate**

Each automatable control within the system is always in one of these four modes.

Rule-Based System

As mentioned before, the system is based on a set of consistent rules that pertain to the behavior of each mode or function. It is the consistency of these rules that allows the system to be simple to understand, yet very deep and powerful. The key to using the system is simply to learn the rules. The rules define how an control or feature will function under a given set of conditions. The conditions that define the exact function of each mode are determined by the selection of other functions, selected options, and record status. With this in mind, it may be helpful to think about Control Mode as the primary function which maybe modified to yield the precise operation the user desires. In a few cases the basic rules will be broken, but these will be clearly noted.

Independent Control Modes

Different channels may be in different automation modes. For example, some channels may be in **Write Enable** while others may be in **Trim Enable**. In addition, different controls within channels may be in different modes. For example the fader may be in **Trim Enable**, while the mute is in **Write Enable**, and the rotaries are in **Read**. Any combination is possible.

Read Lock

With **Read Lock** engaged, all controls are placed in Read mode. All mode changes are locked out, Audition mode is defeated, and only written values will be heard. In this regard, **Read Lock** over-rides Control Mode selections.

Note

In describing the behavior of each Control Mode it is assumed that the **Mix On** function is active and timecode is running. If **Mix On** is not active then all controls behave as if there were in **Isolate** mode.

Document Note

The next several chapters will provide a set of basic rules for each Control Mode. A set of conditions and options that further define the mode's operation will also be provided. The most pertinent conditions and options for each mode will be discussed, but it would be impractical to list every permutation. Some system conditions and options will be discussed as stand alone elements and their effects upon other areas will be noted.

5.7.1 Read

Read is the data replay mode of the system. Controls in **Read** mode will playback changes written in the Mix Pass.

Read Rules

Record Off:

- **REPLAY:** The control plays back the mix data to timecode.
 - Static controls will be set to the value stored within the Mix Pass. (Static values are not timecode stamped.)
 - Dynamic controls will be set to their stored values and subsequent changes will be replayed.
- **AUDITION:** If the control is moved or prevented from following written changes, the audio changes to reflect the 'audition' level.
 - When released the control will snap back to its written value
 - A new Mix Pass is not generated when controls are auditioned.

Record On:

- A control in **Read** cannot be placed into record.

Conditions

- If touched, the control will enter AUDITION for the duration of the touch. When released (un-touched) the control snaps back to its written value.
- With **TOUCH – Hold** engaged, the control will enter AUDITION when touched and holds the audition value when released (un-touched).

<Option>

- With <Read Safe> checked on the Misc. Options page, AUDITION mode is defeated for controls in **Read** and only written values will be heard.

Static Controls

Changes may be made to Static controls while AutoTouchPlus is in **Read** (or any other mode). Changes to Static values are temporarily stored in a global memory buffer (Static Buffer). If a new Mix Pass isn't written, changes to Static controls will be retained in the buffer over time. For example, a section of a song might be looped while adjustments to EQ, Pans, and other controls are made. Changes to these Static controls will accumulate in the Static buffer until a new Mix Pass is generated or the Static Buffer is cleared. The values in the Static Buffer will be saved as part of the next Mix Pass created.

5.7.2 Write

Write Enable is the primary data recording mode of the system. Controls in **Write Enable** are armed for recording and those in **Record** will write changes to a new Mix Pass.

Write Enable Rules

Record Off:

- **Write Enable:** The control acts the same as if it were in **Read** (replaying the mix Read data), but is armed to go into **Record**.
 - A new Mix Pass is not generated unless **Record** is engaged.

Record On:

- **Record:** The absolute value (level) of the control is written into a new Mix Pass.
 - Read mix values are overwritten.
 - At the end of a pass in which at least one control was in **Record**, a new Mix Pass is generated based upon the Active Mix Pass and the newly recorded data.

Note **Record** is a destructive mode in regard that previously written data is overwritten. However, mix data is never lost because a new Mix Pass is generated at the end of every **Record** pass. All Mix Passes are retained in the Mix Tree unless purposely deleted.

The Vistonics concept allows displaying the current and replay values of rotary and fader controls in a very clear and comfortable way.

Rotary Values

Current and replay value of the rotary control: If the current value is different from the one within the last mix pass, a pink colored element indicates the value of the last mix pass, while the main display is indicating the current value.



Fader Values

Current and replay value of the fader: If the current value is different from the one in the last mix pass, a pink colored element indicates the value within the last mix pass, while the main display is indicating the current value.



- Conditions**
- If touched and not in **Record**, the control will enter AUDITION for the duration of the touch. The control will snap back to its Read value upon release.
 - With **TOUCH – Record** engaged, the control will enter **Record** (Punch-in) when touched and return to **Write Enable** (Replay) when released (Punch-out). When released the control will snap back to its Read value unless **Glide** is engaged. If glide is engaged the control will glide back to its Read value.
 - With **TOUCH – Hold** engaged, the control will enter AUDITION mode when touched and holds the audition value when released.
 - With **TOUCH – Record** and **TOUCH – Hold** engaged, the control will enter **Record** (Punch-in) when touched and stays in **Record** when released. The control will stay in **Record** until punched out or the Mix Pass has ended.

Note Refer to [chapter 5.8.5.1](#) for information regarding HELD PLAYS MIX.

- Entering Record** Controls in **Write Enable** can change to **Record** using any of the following three methods:
1. Local Touch (Touching the control on the Channel Strip) or CGM Touch. **TOUCH – Record** engaged or the **ISO (AUTO MODE)** modifier desk key must be used.
 2. Global punch-in via **GLOBAL RECORD – Punch In** button or Auto-Punch or GPI (see [chapter 5.9.5](#)).

5.7.3 Trim

Trim is the update mode of the system. Controls in **Trim Enable** are armed for recording offsets and allows Trims to be Auditioned. Those in **Record** will apply the offset to previously written mix data and the resultant values will be written to a new Mix Pass.

- Faders vs. Other Objects** Trim is handled slightly different for faders than for other automation objects. In both cases, Trim offsets are applied to the Read Mix Data for the Active Pass, and a new Mix Pass is generated. The Read Mix data in the new pass contain the values of the previous Active Pass plus the Trim offset. In addition, for faders, the Trim offset values are stored separately as Trim Replay Data.

- Trim Replay Data** For faders not only is the Trim offset applied to Read Mix data to generate a new Mix Pass, but the offset is stored within the new pass as Trim Replay Data. Trim Replay Data are absolute values that are used to offset fader Read Mix values. Since the Trim Replay Data is separate from the Read Mix Data, it may be manipulated as an independent entity. This means that Trim Replay Data can be rewritten, modified, disabled from replay, and cleared.

Note Since the trimmed fader values are merged with the Read Mix data in the new Mix Pass, the new pass has integrity even if the Trim Replay Data is disabled or cleared.

- Null Indications** When a control is being trimmed, a Null indication is provided. In basic terms, the null indication provides information regarding of the Trim offset value. However, null indications are handled differently for faders than for other controls.

Faders The first time a fader is placed in Trim, the null point is 0 dB and the fader will snap to this position. It should be noted that the fader is showing the null value rather than the Read Mix values and in this case it is 0 dB. As the pass is played, the changes in the Read Mix values will be heard with a 0 dB offset and the fader will not move. When the fader is moved from 0 dB, an offset equivalent to the amount of the move will be applied to the Read Mix data and the net result will be heard.

The offset is displayed by a pink bar (replay value) and a gray bar (current value).

When a recorded Trim is played back with **Trim Enabled**, the fader will move to indicate the Trim offset from 0 dB. If the value of the Trim Replay Data is recorded at -3 dB and then moves to -5 dB, the fader will move to -3 dB and then to -5 dB at the appropriate time. The underlying Read Mix data will be heard with the Trim offset applied. The Trim Replay Data may be updated using Trim Record techniques, thus allowing Trims to be modified. It should be noted that faders in Trim do not follow the WYSIWYH (What You See is What You Hear) paradigm. The recorded moves plus Trim offsets will be heard, but only the Trim Replay values will be shown by the fader.

Encoders Any time an encoder is placed in Trim, the null point will be 0 dB and the encoder will 'auto-null' to this value. Since there is no Trim Replay Data for encoders, the null value can show only the offset of Read Mix values from 0 dB. The null point for encoders is always a 0 dB offset from the Read Mix value.

Whenever an encoder is put in Trim, a 0 dB offset will be used. When a recorded Trim is played back with **Trim Enabled**, the encoder will move to indicate the Trim offset from 0 dB. As the pass is played, the changes in the Read Mix values will be heard with a 0 dB offset and the encoder will not move. When the encoder is moved from 0 dB, an offset equivalent to the amount of the move will be applied to the Read Mix data and the net result will be heard.

The pink-colored bar or dot (replay value) is used to match the current value to the replay value.

Trim Rules **Record Off:**

- **Trim Enable:** The control is armed to go into TRIM RECORD. Faders move to their Trim Replay values and both the Read Mix Data and Trim Replay Data are replayed. The Read Mix values plus the Trim offset will be heard. Any changes made to the Trim value (+/- from the nominal Trim Replay value), will offset the Trim Replay value by that amount. The first time **Trim Enable** is used, faders will display a nominal Trim value of 0 dB. Since the default offset value is 0 dB, the Read Mix Data will be heard unaltered if the control is not moved. While Read Mix data will be heard, it will not be indicated by the fader's position. Encoders display a nominal Trim value. The nominal value will vary depending on the control (i.e. 0 dB for levels/gains, center for stereo panner, etc.). Read Mix Data (Written changes plus any previous Trims) is played back. Any changes made to the Trim value (+/- from the nominal Trim value), will offset the Read Mix values by that amount.

The Read Mix (replay value) is roughly indicated by a pink-colored element.

- If the control is moved while in **Trim Enable** (no Touch modes engaged), the Trim value will be AUDITIONED. The Trim values will offset the Read Mix Data and the net result will be heard. In other words, if the control is moved, the audio reflects the sum of the Read Mix Data plus the offset from the nominal Trim value of the control. So, if the Read Mix Data had a moving value, you will hear that same moving value, except it will be offset by the amount that the control has been moved from the nominal trim value.
- If changes to Trim values have been previously written, faders in **Trim Enable** will normally replay the Read Mix Data (which incorporates the previous Trim values) and the Trim Replay values will be shown on the faders and null indicators. Other controls will replay the Read Mix Data (which incorporates the previous Trim values). Changes to Trim values will be displayed by the control.

Record On:

- TRIM RECORD: Everything is the same as with **Record** Off, except that the Trim values are written into a new Mix Pass. For all controls, the Trim offset is combined with the Read Mix data in the new pass. The Trim Replay data is also modified for faders.
 - Previous Trim values are updated (modifying a trim).
 - At the end of a pass in which at least one control was in TRIM RECORD, a new Mix Pass is generated that contains the previous Mix Pass Read data plus the Trim offset. For faders, the newly recorded Trim Replay Data is generated as well.

Note TRIM RECORD is a destructive mode in regard that previously written Trim data is updated. However, Trim data is never lost because a new Mix Pass is created at the end of every TRIM RECORD pass. All Mix Passes are retained in the Mix Tree unless purposely deleted.

- Conditions**
- If touched and not in **Record**, the control will enter TRIM AUDITION for the duration of the touch. The control will snap back to its Trim value upon release.
 - With **TOUCH – Record** engaged, the control will enter TRIM RECORD (Punch-in) when touched and return to **Trim Enable** (Replay) when released (Punch-out). When released the control will snap back to its Trim value unless **Glide** is engaged. If **Glide** is engaged the control will glide back to its Trim value.
 - With **TOUCH – Hold** engaged, the control will enter TRIM AUDITION mode when touched and holds the audition value when released.
 - With **TOUCH – Record** and **TOUCH – Hold** engaged, the control will enter TRIM RECORD (Punch-in) when touched and stays in TRIM RECORD when released. The control will stay in TRIM RECORD until punched out or the Mix Pass has ended.
- <Option>**
- With <Disable Trim Replay> checked on the Misc Options page, the offset of fader Read Mix Data using Trim Replay Data is defeated and untrimmed audio is heard (also refer to [chapter 5.22.7](#)).

- Automation Menu**
- Selecting **Clear TRIM Replay Data** from the Automation menu in the GC deletes the fader Trim Replay Data and creates a new Mix Pass with 0 dB recorded as the new Trim Replay value.

- Entering TRIM RECORD** Controls in **Trim Enable** can change to **Trim Record** using any of the following methods:
- Local Touch (Touching the control on the Channel Strip) or CGM Touch. **TOUCH – Record** engaged or the **ISO (AUTO MODE)** modifier key must be used.
 - Global punch-in via **GLOBAL RECORD – Punch In** button, or Auto-Punch, or GPI (refer to [chapter 5.9.5](#)).

5.7.4 Isolate

Isolate is the system's manual mode. Controls in **Isolate** neither respond to or create new mix data. In other words, the control is essentially removed from the automation system; it becomes strictly a manual control.

- Note** A control in **Isolate** mode differs from a Static control in regard that changes in an Isolated control's position are not written to Mix Passes. Likewise, Static values are not applied to Isolated controls.

- Isolate Rules**
- Record Off:**
- **Isolate:** The control acts like a manual control and is unaffected by any previously written Read and Trim Replay data.
 - The audio follows the control position
- Record On:**
- A control in **Isolate** cannot be placed into record.

5.7.5 Control Mode Entry

Controls may be put into the various Control Modes using different methods:

- Globally using the Global **CONTROL MODES** Activator buttons and other controls in the ACU window.
- Locally using the channel strip **ISO (AUTO MODE)** key.
- When AutoTouchPlus is turned On using the **Mix On** button in the ACU window (or the **Mix On** desk key). Activating the system will engage the Control Mode selected in the Panel Presets Options page.

- Note** Multiple Control Modes may be active on the console simultaneously.

5.7.5.1 Global Mode Entry

Global Control Mode Entry The primary method to enter automation Control Modes is using the Global **CONTROL MODES** section of the ACU window. Controls that are to enter the mode are ‘preselected’ using **CONTROL MODES** preselector buttons. The preselected controls are then entered into the desired mode using the Global **CONTROL MODES** Activator buttons.

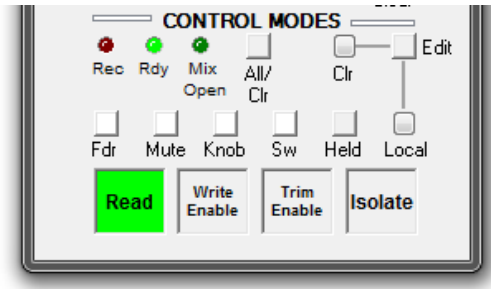

CONTROL MODES Activators There is an activator button for each Control Mode. Clicking one of these buttons puts the preselected controls on all channels into that mode. The controls affected are filtered by the preselectors that are currently active. For example, when only the Fdr preselector is active and the **Write Enable** activator is clicked, only the faders on all channels will change to **Write Enable**. Any other Control Modes that were set on controls other than faders will retain their mode state **<Option>**.

Note When a Global **CONTROL MODES** Activator button is lit, it indicates the Control Mode for all channels. Mode changes made on individual channels will cause the light to go out. Resetting all the Control modes to match on the local level will not cause Global **CONTROL MODES** Activators to re-light.

CONTROL MODES Preselectors Control Mode preselectors determine which controls are selected when a new Control Mode is activated. Multiple preselectors may be active at a time. Any and all combinations are allowed. Preselectors will illuminate when activated. The following describes the control classifications as defined by the **CONTROL MODES** preselectors:

- Fdr (Fader): The fader of all channel types
- Mute: The Mute of all channel types
- Knob (rotary encoders): All continuous controller type encoders (knobs or rotaries). This does *not* include knobs that control ‘selectors’ such as pan format, or phase inversion, for example.
- Sw (Switches): All switches (keys) and selectors (keys and knobs)
- Held (Held Controls): All controls that are currently in a ‘Held’ status (this could be any combination of faders, mutes, switches, and encoders); refer to [chapter 5.8.3, TOUCH – Hold](#).

Note If no preselectors are active, then no controls will be put into the mode of the clicked **CONTROL MODES** Activator.

- All / Clr
- All / Clr: Permits the changing of all of the preselectors at once. This button functions as follows:
 - If one or more preselectors are active, then clicking All / Clr clears all of the preselectors.
 - If no preselectors are active, then *all* preselectors become active.
 - Clicking All / Clr followed by a click on a Control Mode activator will bypass the preselector and select all controls.

This is very handy as follows. If the user wants to set only the fader to a Control Mode and some preselectors are active, it is not necessary to manually disengage each of the currently lit selections. Clicking All / Clr followed by **GLOBAL RECORD – Fdr** will clear all active preselectors and then select fader. This will save several button clicks and improve efficiency.

Another Shortcut If the user wishes to set all of the controls into a specific Control Mode the following method may be used. Rather than clicking All / Clr until all the preselectors are active, just click on All / Clr and the Global **CONTROL MODES** Activator afterwards for the desired Control Mode. *All* control types will be set into that mode and the preselectors will remain in the state that they were.

Other Control Mode Entries Control Modes may entered as part of other automation operations. These operations are as follows:

- Turning Automation on for the First Time: Control Modes are entered based upon the options selected in the Panel Presets Options page. See Options below.
- Setting the Mix Status to on: Control Modes are entered based upon the options selected in the Control Mode Options page. See Options below.
- Recalling a Scene: Controls that have been stored within the Scene Buffer are set to **Write Enable** and come back in a Held state. The stored values are also reset upon recall.
- Engaging **Read Lock**: All controls are placed in READ mode. All mode changes are locked out, AUDITION mode is defeated, and only written values will be heard.

- <Options>
- <When Mix Status is Set to on> (also refer to [chapter 5.22.2](#)): Radio buttons in the Control Modes Options page allow the selection of one of the following options to take effect when Mix Status is set to on (after the first time AutoTouch has been turned on for the first time):
 - <Maintain Object Modes>: When the **Mix On** button in the ACU window (or the **Mix On** desk key) is turned off, all controls are isolated from automation and operate as manual controls. With <Maintain Object Modes> selected, knowledge of the Control Mode for each control is maintained. When the system is turned back on, the Control Mode of all controls is restored.
 - <Set All to Read>: Turning the **Mix On** button (or the **Mix On** desk key) on, after having turned it off, will set all controls to READ.
 - <Set preselector Objects to WRITE>: Any controls that are selected in the Global Control Modes preselector will be set to WRITE. All others will be set to READ.
 - <Set preselector Objects to TRIM>: Any controls that are selected in the Global Control Modes preselector will be set to TRIM. All others will be set to READ.
 - With <Mode Enable sets non-selected to READ> checked in the Control Modes Options page, all controls not preselected are placed in READ

when a new Control Mode is enabled. In other words, only the controls that have been preselected will enter the new mode and all others change to READ.

- <When Loading a Preset>: Radio buttons in the Panel Preset Options page allow the selection of one of the following options to take effect when a Panel Preset is loaded:
 - <Maintain Object Modes>: Loading a Panel Preset will not change the control modes of any of the controls in the console. Current modes will be retained.
 - <Set All to Read>: Loading a Panel Preset will set all controls to READ.
 - <Apply Stored Control Mode>: The Control Modes and preselectors stored within the recalled Preset will be applied.

5.7.5.2 Mode Entry

Local Control Mode Entry Refer to [chapter 5.7.5.2](#)

Global Control Mode Entry Global Control Mode entry is made as described above. However it should be noted that the Global **CONTROL MODES** Activators are located in the **CONTROL MODES** section of the ACU window.

5.7.6 Control Mode Indicators

In automation mode, the channel strips and Vistonics indicators hold additional indications for detailed display of the current status. This chapter shows all possible indications of automation status and explains their meaning.

MUTE Desk Key Record indicators integrated within the channel strip’s recording keys: Current and replay value of the channel mute. If the current value is different from the one in the last mix pass, this key indicates the value within the last mix pass, while the **MUTE LED** indicates the current value.
The MUTE LED is also used for mute indication if ‘solo in place’ is active.

MUTE Rec Recording of the channel mute. If half-lit: Channel mute is armed (i.e., in **Trim Enable** or **Write Enable** mode). If fully lit: Channel mute is recording. Pressing this key will either punch-in the current **MUTE** status, or punch it out of recording.

Displayed Value The meaning of the different Vistonics indicators is as follows: The *displayed value* (e.g. ‘-7.6 dB’) is always the current value, except when the control is in TRIM mode. Then it shows the offset from TRIM null point. It is underlined whenever the control is touched (‘hold’ in automation).



Rotary Value *Current and replay value* of the rotary control. If the current value is different

from the one within the last mix pass, a pink colored element indicates the value of the last mix pass, while the main display is indicating the current value.



Fader Value *Current and replay value of the fader. If the current value is different from the one in the last mix pass, a pink colored element indicates the value within the last mix pass, while the main display is indicating the current value.*



Recording *Recording and recording mode indicator:* This always refers to the associated control. Characters without a frame indicate the status of the rotary control (**I** = Isolate, **R** = Read, **T** = Trim, **W** = Write). A red frame behind the **W** or **T** indicates that the rotary control is currently recording.

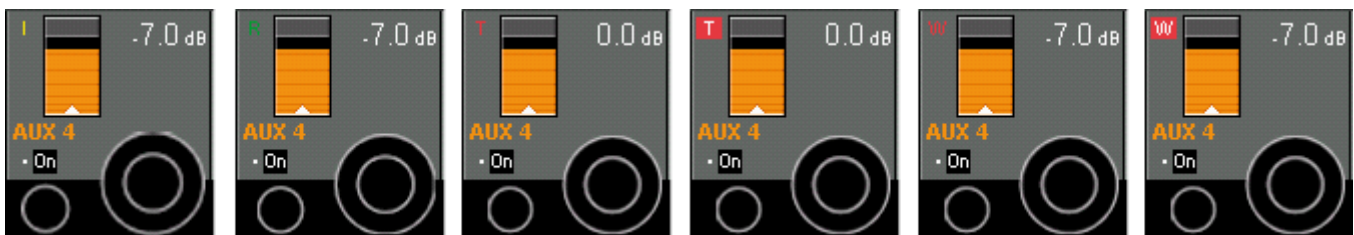

Recording *Recording mode of the fader (in the Visonics generic display area):* Characters without a frame indicate the status of the fader (**I** = Isolate, **R** = Read, **T** = Trim, **W** = Write). A red frame behind the **W** or **T** indicates that the rotary control is currently recording.

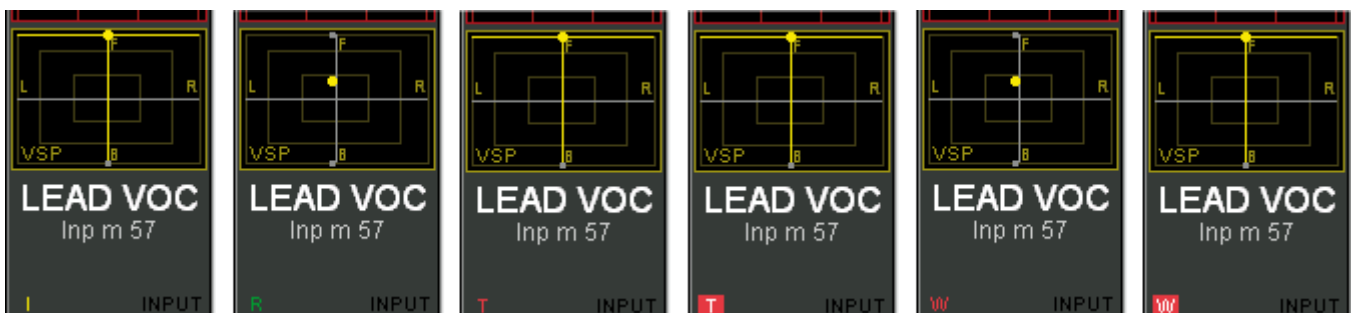

n-1 x **n-1 x** indicates that the channel is the owner of an n-1 bus, together with its bus number - e.g. 'm 1' for 'mono 1'.

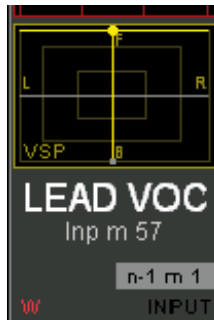

Rotary Dynamic/Static *Dynamic/static view of the rotary control:*
 When clicking the View Dyn button in the ACU window, this display changes to **DYN**, if this control contains dynamically automated elements



Fader Dynamic/Static *Dynamic/static view of the fader:* When clicking the View Dyn button in the ACU window, this display appears and indicates **FADER DYN**, if the fader is dynamically automated.



5.8 Touch and Hold

Touch and Hold functions are key aspects of understanding the AutoTouch-Plus system. Knowledge of these functions and their permutations is essential to the operation of the system. As with Control Modes, there are rules, conditions, and options that determine the precise function of these features.

Faders and Encoders on the channel strip are touch-sensitive. Switches are touch-sensitive in regard that touch events are recognized by the system when a switch is actuated.

Note This chapter will emphasize how touch events relate to Faders and Encoders. Switch automation information will be included, but for complete information regarding Switch automation refer to [chapter 5.11](#).

The activator buttons for Touch and Hold functions are found in the **TOUCH / HELD** section of the AutoTouchPlus window.

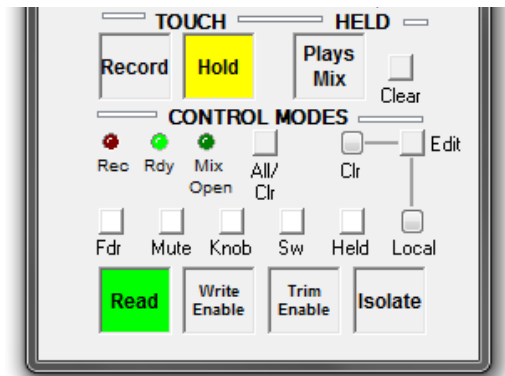

5.8.1 Touch and Un-Touch

Touch/Un-Touch Events Touching a Fader or Encoder is registered by the system as a ‘Touch’ event. Releasing the control is registered as an ‘Un-touch’ event. AutoTouchPlus uses these events to trigger various operations and to toggle between states.

Switches Switches present a special case. This chapter discusses Touch and Un-touch events as they apply to faders and encoders. Please refer to [chapter 5.11](#) for Switch Automation details.

Note It is important to recognize that Touch and Un-touch events are separate and independent events and are used by AutoTouchPlus in different ways. However, Touch and Un-touch are often linked during many operations.

Examples of possible operations that can be triggered by Touch and Un-touch events:

- Touch
 - Enter the enabled mode for that control (i.e. Audition)
 - Punch-in that control (i.e. Enable to Record)
- Un-touch
 - Exit the enabled mode for that control (i.e. Audition)
 - Punch-out that control (i.e. Record to Enable)

Touch-sensitivity is *always* active on the desk, even if **TOUCH – Record**

and/or **TOUCH – Hold** are not active. It should also be noted that when necessary, Touch and Un-touch events can be suppressed to facilitate specific functionality.

- Basic Touch/Un-touch Events** Touch/Un-touch events can be registered without **TOUCH – Record** or **TOUCH – Hold** engaged. These events perform the following functions when dynamic controls are in the Control Modes indicated:
- **READ:** Touch/Un-touch will toggle the control in and out of AUDITION. The control will change from READ to AUDITION when touched and will snap back to recorded values (READ) when released.
 - **WRITE ENABLE:** Touch/Un-touch will toggle the control in and out of AUDITION
 - **TRIM ENABLE:** Touch/Un-touch will toggle the control in and out of TRIM AUDITION
 - **ISOLATE:** Touch/Un-touch events of Isolated controls are not recognized by AutoTouchPlus.
- <Option>**
- With <Read Safe> checked in the Misc Options page, AUDITION mode is defeated for controls in READ and only Read Mix values will be heard (also refer to [chapter 5.22.7](#)).

5.8.2 Touch Record

With **TOUCH – Record** (ACU button or desk key) engaged, touching a **Write** or **Trim Enabled** control will change it from ENABLE to RECORD. This will effectively perform a ‘Punch-In’ for that control. Touching a control in READ will change it to AUDITION.

When released, a control in RECORD will change back to ENABLE, effectively ‘Punching-Out’ (if **TOUCH – Hold** is not engaged). Subsequent Touch/Un-touch events will toggle that control in and out of RECORD. Likewise a control in AUDITION will revert to READ when released.

To sum it up, if **TOUCH – Record** is used alone (without **TOUCH – Hold**) controls will change to either RECORD or AUDITION for the duration of the human contact with the control.

- TOUCH – Record** With only **TOUCH – Record** engaged (without **TOUCH – Hold**), Touch/Un-touch events perform the following functions when dynamic controls are in the Control Modes indicated:
- **READ:** Touch/Un-touch will toggle the control in and out of AUDITION.
 - **WRITE ENABLE:** Touch/Un-touch will toggle the control in and out of RECORD. The control will change from WRITE ENABLE to WRITE RECORD when touched and will snap back to recorded values (WRITE ENABLE) when released. The control will glide back if **Glide** is engaged.
 - **TRIM ENABLE:** Touch/Un-touch will toggle the control in and out of RECORD. The control will change from TRIM ENABLE to TRIM RECORD when touched and will snap back to recorded Trim values (TRIM ENABLE) when released. The control will glide back if **Glide** is engaged.
 - **ISOLATE:** Touch/Un-touch events of Isolated controls are not recognized by AutoTouchPlus.

Note The examples above assume that Write To: **Punch Out** is active. Refer to [chapter 5.10.1](#).

- <Option>**
- With <Read Safe> checked in the Misc. Options page, AUDITION mode

is defeated for controls in READ, and only written values will be heard.

- The **TOUCH – Record** button may be overridden by checking options in the <Master Panel Overrides> section of the Master Panel Options page. Faders and Encoders can have **TOUCH – Record** set to <ON>, <OFF>, or to follow the ACU window <Follows Panel>. **TOUCH – Record** for Switches can also have <ON> and <OFF> overrides or be set to follow the ACU window <Follows Panel>.

5.8.3 Touch Hold

With **TOUCH – Hold** (ACU button or desk key) engaged, touching a control will change it to being in a ‘held’ state.

- Held Controls** Controls that are in Held status have specific functional qualities:
- They maintain their current status when physically released (Un-touched)
 - They may be selected as a group (Held Objects) for additional automation operations (such as a preselector set).

When **TOUCH – Hold** is activated the Touch event is registered by the system and the Un-touch event is suppressed. Touching a control will change it to the next mode available. More importantly, the control will ‘hold’ that mode when it is released.

When released, a control in RECORD will not punch-out and change back to ENABLE, it will stay in RECORD. Likewise a control in AUDITION will not revert to READ when released.

To sum it up, if **TOUCH – Hold** is used alone (without **TOUCH – Record**), controls will change to their AUDITION modes and stay there when released.

- TOUCH – Hold** With only **TOUCH – Hold** engaged (without **TOUCH – Record**), Touch events perform the following functions when dynamic controls are in the Control Modes indicated (remember Un-touch events are suppressed):
- READ: Touch will change to and stay in AUDITION.
 - WRITE ENABLE: Touch will change to and stay in AUDITION.
 - TRIM ENABLE: Touch will change to and stay in TRIM AUDITION.
 - ISOLATE: Touch/Un-touch events of Isolated controls are not recognized by AutoTouchPlus.

- <Option>**
- With <Read Safe> checked in the Misc Options page (see [chapter 5.22.7](#)), AUDITION mode is defeated for controls in READ, and only written values will be heard.
 - The **TOUCH – Hold** button may be overridden by checking options in the <Master Panel Overrides> section of the Master Panel Options page (see [chapter 5.22.5](#)). Faders and Encoders can have **TOUCH – Hold** set to <ON>, <OFF>, or to follow the ACU window <Follows Panel>. **TOUCH – Hold** for Switches can also have <ON> and <OFF> overrides or be set to follow the ACU window <Follows Panel>.

5.8.4 Touch Record + Touch Hold

TOUCH – Record and **TOUCH – Hold** can be used together to create a condition where controls will change to RECORD (if currently enabled) or AUDITION (if currently in READ) when touched and stay in that mode when released.

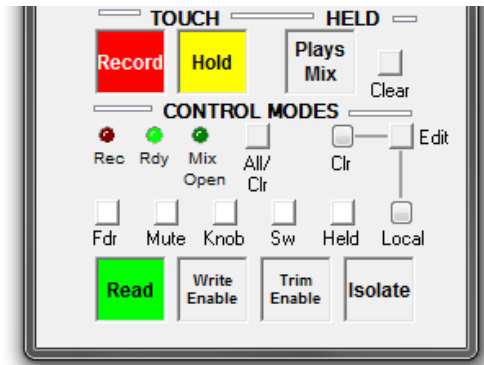

With both **TOUCH – Record** and **TOUCH – Hold** engaged, touching a control will change it from its current state to the next mode available and then will ‘hold’ that mode (remember, when **TOUCH – Hold** is activated, the Touch event is registered by the system and the Un-touch event is suppressed).

When released, a control in RECORD will not punch-out and change back to ENABLE, it will stay in RECORD. Likewise a control in AUDITION will not revert to READ when released.

TOUCH–Record + TOUCH–Hold With both **TOUCH – Record** and **TOUCH – Hold** engaged, Touch events perform the following functions when dynamic controls are in the Control Modes indicated (remember Un-touch events are suppressed):

- READ: Touch will change to and stay in AUDITION.
- WRITE ENABLE: Touch will change the control from WRITE ENABLE to WRITE RECORD and stay in WRITE RECORD when released.
- TRIM ENABLE: Touch will change the control from TRIM ENABLE to TRIM RECORD and stay in TRIM RECORD when released.
- ISOLATE: Touch/Un-touch events of Isolated controls are not recognized by AutoTouchPlus.

- <Option>
- With <Read Safe> checked in the Misc Options page (see [chapter 5.22.7](#)), AUDITION mode is defeated for controls in READ, and only written values will be heard.
 - The ACU window **TOUCH – Record** and **TOUCH – Hold** buttons may be overridden by checking options in the <Master Panel Overrides> section of the Master Panel Options page (see [chapter 5.22.5](#)). Faders and Encoders can have **TOUCH – Record** and **TOUCH – Hold** set to <ON>, <OFF>, or to follow the ACU window <Follows Panel>. **TOUCH – Record** and **TOUCH – Hold** for Switches can also have <ON> and <OFF> overrides or be set to follow the ACU window <Follows Panel>
 - The Un-touch function of either **TOUCH – Record** and **TOUCH – Hold** may be changed by using the **ISO (AUTO MODE)** modifier key. For details, refer to [chapter 5.8.6](#).

5.8.5 Held Controls

A control that is touched with **TOUCH – Hold** engaged becomes a ‘held’ control. Held controls are also known as ‘Held Objects.’ Controls that are held not only stay in their Touched mode when released, they are identified by the system as being held.

HELD Controls Buffer As controls are placed into a held status, they are added to a list of controls stored in the ‘Held Controls Buffer.’ The **HELD – Clr** button in the **HELD** section of the ACU window will light if one or more control is held. The Held Controls list is used as a filter for the **HELD** preselectors in the Control Modes and Global Record sections of the ACU window.

Clearing Held Controls *Clear Held Controls Buffer:* Clicking the **HELD – Clr** button will take all Held controls out of hold. It will also clear the list of controls in the Held Controls Buffer.

Clear Held Controls Modes: Controls may be taken out of hold in the following ways:

- When **TOUCH – Hold** is turned OFF <Option>
- Upon Punch-Out <Option>
- At the end of a Mix Pass <Option>

- <Option> • With <When Touch Hold Turned Off> checked in the <Clear Held Objects> section of the Hold Options page (also refer to [chapter 5.22.4](#)), all held controls are cleared when **TOUCH – Hold** is turned Off.
- With <Upon Punch-Out> checked in the <Clear Held Objects> section of the Hold Options page, any Held control is cleared upon punch-out.
- With <Held Objects> checked in the <End of Pass Clears> section of the End of Pass Options page, all held controls are cleared at the end of each Mix Pass.

Note The **TOUCH – Hold** button in the ACU window may be overridden by checking options in the <Master Panel Overrides> section of the Master Panel Options page (also refer to [chapter 5.22.5](#)). Faders/Encoders and Switches can have **TOUCH – Hold** set to <ON> as a default option. When using this option, care should be taken not inadvertently place controls into Hold.

5.8.5.1 Held Plays Mix

When the **HELD – Plays Mix** button is engaged, all Held controls play their Read Mix data when not in RECORD, but the controls can be set to different physical positions.

The Read Mix data is heard, even though one or more controls are being held in AUDITION. This allows a held control to be pre-positioned while awaiting a punch-in. The result is true emulation of the resultant mix, while the Mix Pass is being run.

- <Option> • With <Disabled While Touched> checked in the <Held Plays Mix> section of the Hold Options page (also refer to [chapter 5.22.4](#)) and **HELD – Plays Mix** engaged, all held controls that are touched will change to AUDITION for the duration of the touch. The AUDITION value will be heard while the control is being touched. Upon release held controls revert to playing the Read mix. This is useful when pre-positioning the control before the

punch. This ‘TOUCH AUDITION’ mode allows the Punch-In value to be determined by touching and moving the control to the desired position and releasing it to return to hearing the Read mix. The control retains its AUDITION value awaiting Punch-In while the Read mix is heard.

5.8.6 ISO (Auto Mode) Key Function

ISO (AUTO MODE) Key The channel strip ISO (AUTO MODE) key is also known as ‘modifier key.’



ISO (AUTO MODE) Key Function

Holding the ISO (AUTO MODE) key down temporarily reverses the state of the **TOUCH – RECORD** key on a local basis. For example, if **TOUCH – Record** is activated in the ACU window, holding down the ISO (AUTO MODE) key will deactivate **TOUCH – Record** on that channel as long as the key is held down. If however **TOUCH – Record** is not active, holding the ISO (AUTO MODE) key will activate it for that channel.

Using the ISO (AUTO MODE) Key

The ISO (AUTO MODE) key may be used as follows:

- Global **TOUCH – Record** Active:
 - Holding the ISO (AUTO MODE) key will deactivate **TOUCH – Record** for that channel. This will allow enabled controls to be auditioned on a local basis without being punched-in.
 - Touching an enabled control will punch it in, holding it will keep it in RECORD. Pressing and holding the ISO (AUTO MODE) key before the control is released will deactivate **TOUCH – Record**. When it is released, the control will not punch-out and will stay in RECORD in a Held state.
- Global **TOUCH – Record** Inactive:
 - Holding the ISO (AUTO MODE) key will activate **TOUCH – Record** for that channel. This will allow enabled controls to be punched-in on a local basis.
 - Holding the ISO (AUTO MODE) key and releasing a control that is in RECORD will punch that control out. In this case, the control may be touched at any time, but the ISO (AUTO MODE) key must be pressed at the time of release for a punch-out to occur.

Note To achieve the function mentioned above when Global **TOUCH – Record** is inactive, the ‘Modified Untouch Inverts’ option (radio button **TOUCH – Record**) must be selected (also refer to [chapter 5.22.7](#)).

5.8.6.1 Modified Un-touch Inverts

As an option, **TOUCH – Record** or **TOUCH – Hold** may have their modified Un-touch function inverted. In other words, if the **ISO (AUTO MODE)** key is held down when a control is Un-touched (released) the normal Un-touch function of **TOUCH – Record** or **TOUCH – Hold** will be reversed.

Either **TOUCH – Record** or **TOUCH – Hold** may be selected for Un-touch inversion, but not both.

- <Option>
- Either the **TOUCH – Record** or **TOUCH – Hold** function may be selected for Modified Un-touch Inversion when the **ISO (AUTO MODE)** key is held. This selection is made by clicking the desired radio button in the <Modified Un-touch Inverts> section of the Misc Options page (also refer to [chapter 5.22.7](#)).

5.8.6.1.1 Option Modified Un-Touch Inverts <Touch Record>

Both Global TOUCH – Record and Global TOUCH – Hold inactive:

- 1a** Holding the **ISO (AUTO MODE)** key when an enabled control is touched, will punch that control in RECORD. As long as the **ISO (AUTO MODE)** key is held down, a touched control will be in RECORD. Un-touching the control will return the status from RECORD to ENABLE.
- 1b** If the control is touched and the **ISO (AUTO MODE)** key is released before the control is physically un-touched, the control will remain in RECORD even if the control is physically un-touched.
Even if the control remains in RECORD, the un-touch information is suppressed.
- 1c** A control being in RECORD can be punched out by holding the **ISO (AUTO MODE)** key, and touching and un-touching the control while the **ISO (AUTO MODE)** key is being pressed. The control changes from RECORD to ENABLE when the control is physically un-touched.

Global TOUCH – Record active, Global TOUCH – Hold inactive:

- 2a** While pressing the **ISO (AUTO MODE)** key, touching of a control that is in ENABLE mode will not punch it into RECORD.
- 2b** Touching the control (causing it to change from ENABLE to RECORD) and pressing the **ISO (AUTO MODE)** key while still touching the control, then releasing the control while still pressing the **ISO (AUTO MODE)** key will cause the control to remain in RECORD and HELD status.

Global TOUCH – Record inactive, Global TOUCH – Hold active:

- 3a** Keep the **ISO (AUTO MODE)** key pressed. Touching and untouching a control in ENABLE mode will punch the control in and out of RECORD. *Please note that the control is in HELD status, regardless whether it is in RECORD or not.*
- 3b** Keep the **ISO (AUTO MODE)** key pressed and touch a control that is currently in ENABLE mode. Keep the control touched and release the **ISO (AUTO MODE)** key. The control will remain in RECORD.

- 3c** A control being in RECORD mode can be punched out by keeping the **ISO (AUTO MODE)** key pressed, then touching and un-touching the control. At the moment the control is released, it punches out of RECORD but remains in HELD status.

Both Global TOUCH – Record and Global TOUCH – Hold active:

- 4a** While keeping the **ISO (AUTO MODE)** key pressed, touching a control in ENABLE mode will not PUNCH-INTo RECORD. The control will remain in HELD status.
- 4b** A control being in RECORD status can be punched out by keeping the **ISO (AUTO MODE)** key pressed, then touching and un-touching the control. At the moment the control is released, it punches out of RECORD while remaining in HELD status.

5.8.6.1.2 Option Modified Un-Touch Inverts <Touch Hold>

Both Global TOUCH – Record and TOUCH – Hold inactive:

- 5a** While keeping the **ISO (AUTO MODE)** key pressed, touching a control in ENABLE mode will switch it to RECORD and HELD status. When releasing the control it will remain in RECORD and TOUCHED.

Global TOUCH – Record active, TOUCH – Hold inactive:

- 6a** While keeping the **ISO (AUTO MODE)** key pressed, touching a control in ENABLE mode will switch it to HELD but not to RECORD status, if the control is released before the **ISO (AUTO MODE)** key.
- 6b** While keeping a control in ENABLE mode touched, press the **ISO (AUTO MODE)** key. Then release the control before releasing the **ISO (AUTO MODE)** key, causing the control to switch to RECORD and HELD status.

Global TOUCH – Record inactive, TOUCH – Hold active:

- 7a** While keeping the **ISO (AUTO MODE)** key pressed, touching a control in ENABLE mode will switch it to RECORD but not to HELD mode, if the control is released before the **ISO (AUTO MODE)** key.

Both Global TOUCH – Record and TOUCH – Hold active:

- 8a** While keeping the **ISO (AUTO MODE)** key pressed, touching a control in ENABLE mode will not punch the control into RECORD. When releasing the control while the **ISO (AUTO MODE)** key is still pressed, the control will not jump back to the replay value.
- 8b** A control being in RECORD can be punched-out by pressing the **ISO (AUTO MODE)** key, then touching the control and releasing it while the **ISO (AUTO MODE)** key is still pressed. At the same time the control's HELD status is cleared.

| Ref. | Step | Global Record | Global Hold | ISO (AUTO MODE) Key Action | Control Action | Control Status Condition/Reaction |
|------|------|---------------|-------------|----------------------------|----------------|-----------------------------------|
| 1a | | OFF | OFF | | | ENABLE |
| | 1 | OFF | OFF | Press + Hold | | ENABLE |
| | 2 | OFF | OFF | Hold | Touch | RECORD |
| | 3 | OFF | OFF | Hold | Un-touch | ENABLE |
| 1b | | OFF | OFF | | | ENABLE |
| | 1 | OFF | OFF | Press + Hold | | ENABLE |
| | 2 | OFF | OFF | Hold | Touch + Hold | RECORD |
| | 3 | OFF | OFF | Release | Hold | RECORD |
| 1c | | OFF | OFF | | | RECORD |
| | 1 | OFF | OFF | Press + Hold | Touch | RECORD |
| | 2 | OFF | OFF | Hold | Un-touch | ENABLE |
| | | | | | | |
| 2a | | ON | OFF | | | ENABLE |
| | 1 | ON | OFF | Press + Hold | | ENABLE |
| 2b | | ON | OFF | | | E (no change) |
| | 1 | ON | OFF | | Touch | RECORD |
| | 2 | ON | OFF | Press + Hold | Hold | RECORD |
| | 3 | ON | OFF | Hold | Un-touch | RECORD + HELD |
| 3a | | OFF | ON | | | ENABLE + HELD |
| | 1 | OFF | ON | Press + Hold | | ENABLE + HELD |
| | 2 | OFF | ON | Hold | Touch | RECORD + HELD |
| | 3 | OFF | ON | Hold | Un-touch | ENABLE + HELD |
| 3b | | OFF | ON | | | ENABLE |
| | 1 | OFF | ON | Press + Hold | | ENABLE |
| | 2 | OFF | ON | Hold | Touch + Hold | RECORD |
| | 3 | OFF | ON | Release | Hold | RECORD |
| 3c | | OFF | ON | | | RECORD |
| | 1 | OFF | ON | Press + Hold | | RECORD |
| | 2 | OFF | ON | Hold | Touch | RECORD |
| | 3 | OFF | ON | Hold | Un-touch | ENABLE + HELD |
| 4a | | ON | ON | | | ENABLE |
| | 1 | ON | ON | Press + Hold | | ENABLE |
| | 2 | ON | ON | Hold | Touch | ENABLE + HELD |
| 4b | | ON | ON | | | RECORD |
| | 1 | ON | ON | Press + Hold | | RECORD |
| | 2 | ON | ON | Hold | Touch | RECORD |
| | 3 | ON | ON | Hold | Un-touch | ENABLE + HELD |
| 5a | | OFF | OFF | | | ENABLE |
| | 1 | OFF | OFF | Press + Hold | | ENABLE |
| | 2 | OFF | OFF | Hold | Touch | RECORD + HELD |
| | 3 | OFF | OFF | Hold | Un-touch | RECORD + HELD |

| Ref. | Step | Global Record | Global Hold | ISO (AUTO MODE) Key Action | Control Action | Control Status Condition/Reaction |
|------|------|---------------|-------------|----------------------------|----------------|-----------------------------------|
| 6a | | ON | OFF | | | ENABLE |
| | 1 | ON | OFF | Press + Hold | | ENABLE |
| | 2 | ON | OFF | Hold | Touch | ENABLE |
| | 3 | ON | OFF | Hold | Un-touch | ENABLE + HELD |
| 6b | | ON | OFF | | | ENABLE |
| | 1 | ON | OFF | | Touch + Hold | RECORD |
| | 2 | ON | OFF | Press + Hold | | RECORD |
| | 3 | ON | OFF | Hold | Un-touch | RECORD + HELD |
| 7a | | OFF | ON | | | ENABLE |
| | 1 | OFF | ON | Press + Hold | | ENABLE |
| | 2 | OFF | ON | Hold | Touch | RECORD |
| | 3 | OFF | ON | Hold | Un-touch | RECORD (not HELD) |
| 8a | | ON | ON | | | ENABLE |
| | 1 | ON | ON | Press + Hold | | ENABLE |
| | 2 | ON | ON | Hold | Touch | ENABLE |
| | 3 | ON | ON | Hold | Release | ENABLE |
| 8b | | ON | ON | | | RECORD |
| | 1 | ON | ON | Press + Hold | | RECORD |
| | 2 | ON | ON | Hold | Touch | RECORD |
| | 3 | ON | ON | Hold | Release | ENABLE (not HELD) |

5.9 Global Record

Controls can be ‘punched in and out’ on a global basis. Global punch-ins and punch-outs are accomplished in one of three ways:

1. Manually: Using the **Punch In** and **Punch Out** activator buttons in the **GLOBAL RECORD** section of the ACU window
2. Automatically: Enabling the Write Zone and **Punch In/Out** in the ‘Auto-Touch Plus’ window of the Graphical Controller (GC). Refer to [chapter 5.9.4](#), Auto Punch-In/Out.
3. Automatically via a GPI input (refer to [chapter 5.9.5](#)).

Conditions If no controls of the type chosen of the **GLOBAL RECORD** preselector are enabled, Global **Punch In** has no effect. Likewise, if no controls of the type chosen of the **GLOBAL RECORD** preselector are in record mode, Global **Punch Out** has no effect.

Note Individual controls can be punched in and out independently of the **GLOBAL RECORD** functions. This is done locally on the channel strip.

5.9.1 Preselectors

Preselectors Regardless of the punch method used, the **GLOBAL RECORD** preselectors determine which controls are affected when a global PUNCH-IN occurs.



Multiple preselectors may be active at a time. Any and all combinations are allowed. Preselectors will illuminate when active.

The following describes the control classifications as defined by the **GLOBAL RECORD** preselectors:

- **Fdr (Fader)**: The fader of all channel types
- **Mute (Mute)**: The Mute of all channel types
- **Knob (Encoders)**: All continuous rotary type encoders. This does *not* include knobs that control ‘selectors’, such as pan format or phase inversion.
- **Sw (Switches)**: All switches (keys) and selectors (keys and knobs)
- **Held (Held Controls)**: All controls that are currently in a ‘Held’ status. (This could be any combination of faders, mutes, switches, and encoders). Refer to [chapter 5.8.3](#).

Note If no preselectors are active, then no controls will be punched-in or out.

- All / Clr**
- Permits changing all preselectors at once:
 - If one or more preselectors are active, then clicking **All / Clr** clears all of the preselectors.
 - If no preselectors are active, then **ALL** preselectors get active.
 - Clicking **All / Clr** followed by a click on **Punch In** or **Punch Out** will bypass the preselector and select all controls.

5.9.2 Manual Punch-In/-Out

The manual **Punch In** and **Punch Out** activators are located in the **GLOBAL RECORD** section of the ACU window. As described above, the controls to be punched in and out are chosen using **GLOBAL RECORD** preselectors and then manually ‘punched in and out’ of Record using the **Punch In** and **Punch Out** activator buttons.

- Punch In / Punch Out Activators**
- **Punch In:** Clicking **Punch In** puts the preselected controls on all channels into RECORD (if enabled). As with Control Mode entries, the controls affected are filtered by the preselectors that are currently active.
 - **Punch Out:** Clicking **Punch Out** takes the preselected controls on all channels out of RECORD (if enabled). As with Control Mode entries, the controls affected are filtered by the preselectors that are currently active.

Note Whenever any control is in RECORD the **Punch In** and **Punch Out** buttons are lit.

5.9.3 Write Zone

The **Write Zone** is a region between two user-specified timecode locations. When the **Write Zone** is enabled, recording may take place only within that timecode region.

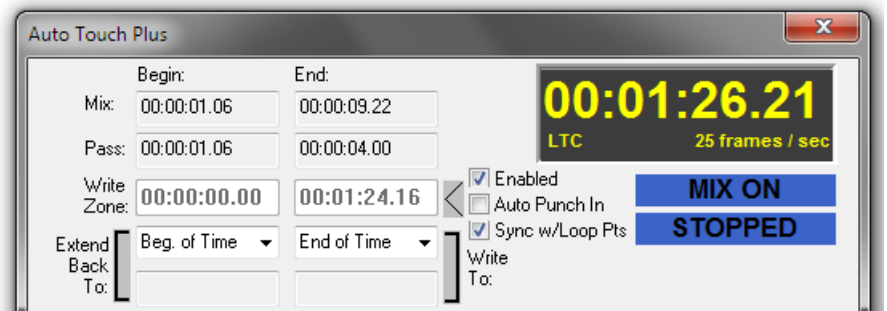

- Write Zone Functions**
- When **Write Zone** is enabled, the following conditions are in place:
- Record is locked out before the **Write Zone - Begin Time**.
 - Record is locked out after the **Write Zone - End Time**.
 - Recording is allowed only between the **Write Zone - Begin** and **End Time**.
 - Any controls in RECORD will punch-out at the **Write Zone - End** if timecode is played through the **End Time** (with or without **Auto Punch In** engaged).
 - If **Auto Punch In** is engaged, enabled controls will punch-in at the **Write Zone - Begin Time** if timecode is played through the **Begin Time**.

Enabling the Write Zone The **Write Zone** is enabled by checking the ‘**Write Zone Enabled**’ box in the **AutoTouchPlus** window. If this box is unchecked the **Write Zone** has no affect.

Write Zone - Begin Time The **Write Zone - Begin Time** is the timecode location before which recording is locked out, assuming the **Write Zone** is enabled. Recording is allowed only after the **Write Zone - Begin Time**, but only up to the **Write Zone - End Time**.

Auto Punch In If **Auto Punch In** is engaged, a punch-in will occur for enabled controls when the **Write Zone - Begin Time** is encountered.

Write Zone - End Time The **Write Zone - End Time** is the timecode location after which Recording is locked out, assuming the **Write Zone** is enabled. Recording is allowed only before the **Write Zone - End Time**, but only after the **Write Zone - Begin Time**.

Sync w/Loop Pts Checking the **Sync w/Loop Pts** function allows to set the **Write Zone In** an **Out points**, according to the selected cue points in the **AutoTouchPlus** window.

Any controls in **RECORD** will punch-out when the **Write Zone - End Time** is encountered. This happened whether **Auto Punch In** is engaged or not.

Write Zone-Begin/End Time Entry The **Write Zone - Begin** and **End times** may be entered in the following ways:

- Highlighting all or part of the **Begin** or **End Time** entry field and typing in the new time;
- Highlighting all or part of the **Begin** or **End Time** entry field and rolling the time up or down using click/drag methods
- Highlighting all or part of the **Begin** or **End Time** entry field and using the up or down arrow buttons
- Selecting a time from the **Right-Click** menu
- Clicking + or – followed by a numeric value
- Using the **Sync w/Loop Pts** function.

The **Write Zone** must be enabled before **Begin/End Time** entry is permitted.

Hot Keys Hot Keys are provided to aid in the entry of fixed **Begin** and **End** timecode locations. A complete description of Hot Key functions is provided in [chapter 5.24](#).

Entry Field Right-click Menu Right-clicking either Write Zone entry fields will open the Entry Field Right-click menu.

This menu contains several items that assist the user in quickly entering timecode values. These items are organized in five basic areas:

- Significant System Times: Mix Begin, Mix End, Current Time, Clear (00:00:00.00), and End of Day (23:59:59.23)
- Cue List Times: Allows access to the Title Cue List and provides the means to sort and go to cues,
- Copy/Paste/Undo Changes: Entry field clipboard functions
- Most Recent: A list of the most recently used timecode locations is maintained by the system. Timecode locations from this list may be selected for the entry field value. The most recent timecode (current value) may be locked as the entry field value, to prevent it from being changed. A timecode may be manually added to the list. The list may be sorted and deleted.

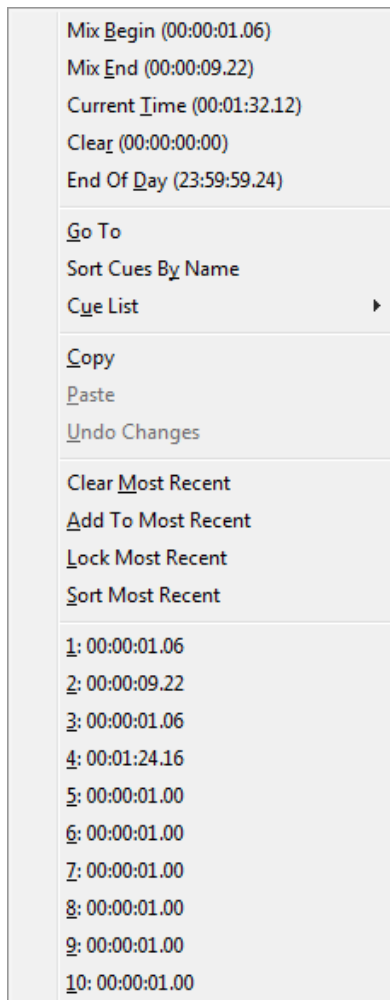

5.9.4 Auto Punch-In/Out

Automatic punch-in/punch-out is controlled via the AutoTouchPlus window of the GC.

- Write Zone** To set up an Auto Punch In/Out, a Write Zone with a Begin and End time must first be established. These will be the In and Out points for the Auto Punch In/Out. The times displayed were the last In and Out times used by the system. Direct entry of Begin and End times is possible once the Write Zone is enabled. Refer to [chapter 5.9.3](#) for details.
- Auto Punch In** To activate the Auto Punch In feature, the Write Zone must first be enabled, which is done by checking the Enabled box next to the End time field. Once the Write Zone is enabled, it is then possible to enable the Auto Punch In facility. This is accomplished by checking the Auto Punch In box located below the Write Zone Enabled box.

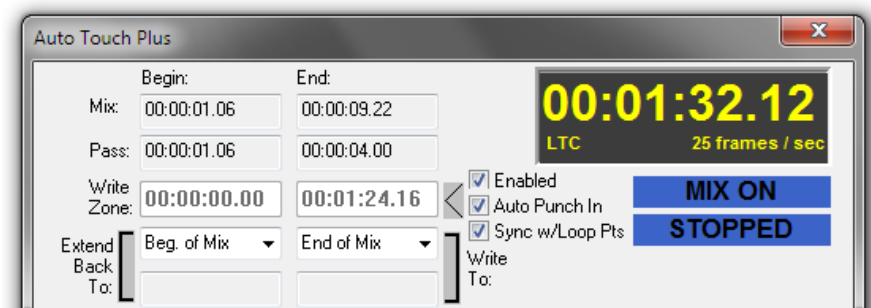

- Performing the Punch** Once Auto Punch In is enabled and the desired controls are enabled, play back timecode (media). During the pre-roll before the Begin Time, the affected controls will act as if in RECORD ENABLE, but will not punch-in until the Write Zone Begin time.

At the Begin time, the system will automatically punch in and any enabled controls will change to RECORD. Recording will continue until the End time is reached, where the controls are automatically punched out.

- Notes** It is possible to punch-out any individual control at any time within the Write Zone using the **ISO (AUTO MODE)** key. Global punch-outs may also take place before the end of the Write Zone. It is not possible to punch-in before the Begin time or after the End time when the Write Zone is enabled. Glide functions may be used with Auto Punch-In/Out. Since changes to the Read Mix are prohibited after the Write Zone End time, the Backtime Glide function must be used if Auto Punch-out is used.

5.9.5 Auto Global Punch-In/Out

Global Punch-Ins and Punch-Outs can also be done via the GPI input. This will basically make the Punch In and Punch Out buttons available to external systems or external keys.

If such functionality is required, the `signaling.ini` file needs to be adapted accordingly. Please contact Studer Service & Support to do the necessary changes in that file.

5.10 Data Transition Behavior

Data Transitions In simplest terms, a Data Transition takes place whenever new data meets old data. In more formal terms, a data transition is where Record Mix Data transitions to Read Mix Data and vice versa. This means a transition takes place when Read Mix Data transitions to Record data (such as at a punch in) and when the Record Data transitions to Read Mix Data (such as a punch out).

Note: Data Transitions are not limited to punch-in and punch-out locations.

Last Recorded Value The Last Recorded Value is always the current value of the control at the time it is punched out. However, it should be noted that this value might have been set well before the actual punch-out. In this case, the location of the Last Recorded Value is earlier than the punch-out location.

By definition, the Last Record Value is a Dynamic value. However, it should be noted that it is a singular, non-moving value.

Understanding Behaviors One of the key aspects to AutoTouchPlus is understanding where the Last Recorded Value transitions to and from Read Mix data and how it makes the transitions.

The ‘where’ behavior is determined in two ways:

- **Write To:** Where Record Data transitions to Read Mix Data
- **Extend Back To:** Where Read Data transitions to Record Data

The Last Recorded Value may be applied up to or beyond the punch-out point. It may also be applied back to the punch in point or before. These behaviors will be discussed below.

The ‘how’ behavior is determined by whether the **Glide** function is On or Off and the Glide Options enabled.

5.10.1 Write To:

The choice of **MIX PASS – Write To:** function determines where the Record Data-to-Read Mix Data transition takes place. In essence, the concept is as follows:

‘Take the last recorded value and write it to: _____!’

The blank can be filled in with one of following **Write To:** locations:

- **Punch Out:** Apply the last recorded value to the punch-out location
- **Next Chng:** Apply the Last Recorded Value to the location of the next recorded change
- **Level Match:** Apply the Last Recorded Value until the it matches the Read Mix value
- **End:** Apply the Last Recorded Value to the specified End Time.

These locations are also known as **Write To:** Functions.

Note Unlike other automation systems, the transition from Record Data to Read Mix Data does not necessarily have to take place at the punch out location. In fact, selecting **Write To: Punch Out** is the only time that both happen simultaneously.

Write To: Buttons The **MIX PASS** – Write To: buttons determine the point at which the transition from Record Data to Read Mix Data will take place. As noted above, there are four different Write To: functions, one of which must be selected. The selected function button will illuminate when that function is active. Only one function can be active at a time.

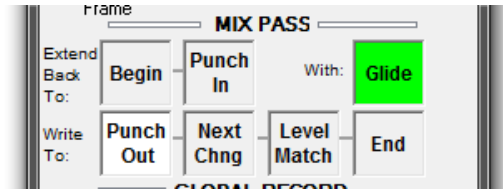

The four Write To: functions behave as follows:

- **Punch Out:** The Last Recorded Value (punch out value) will be applied until the Punch out point. At the punch out point, the Record Data will transition to the Read Mix Data. **Punch Out** is the default Write To: function.
- **Next Change:** The Last Recorded Value will be applied until the next recorded change in the Read Mix Data. At that point, the Record Data will transition to Read Mix Data.
- **Level Match:** The current value of the control (by definition the Last Recorded Value) will be written until it matches the Read Mix Data. At this point, the Record Data will seamlessly transition to the Read Mix Data and a punch out will occur. If a punch out occurs without the level being matched, the control will not actually punch out until the levels match. Any moves that are made before the levels match will be recorded. Matching level may be accomplished by either moving the control to match the Read Mix value or positioning the control where the Read Mix values will intercept the physical position.
- **End:** The Last Recorded Value will be applied until the user-specified **End** Time. All previously recorded values between the Last Recorded Value (typically Punch Out) and the **End** Time will be erased.

The **End** Time is defined in three different ways:

- End of Mix: The Last Recorded Value will be applied until the End Time of the Active Mix.
- End of Time: The Last Recorded Value will be applied up to the last possible timecode location (i.e. 23:59:59.2X). The number of frames will be determined by the selected timecode frame rate.
- Fixed...: The Last Recorded Value will be applied up to a 'fixed' user-selected End Time. See Setting a Fixed End Time below.

Post Pass Processing

Next Change, **Level Match**, and **End** transitions do not have to be performed in real-time. The active **Write To:** function will take place even after timecode playback has stopped at the end of Record Pass. This saves time by eliminating the need to perform complete real-time passes when a control's value can be written to a known location. This also means it is possible to overwrite mix data in locations that have not been heard. Care is suggested while using **Write To:** functions.

Important Note

Write To: Next Change, **Level Match**, and **End** are destructive functions in the regard that they will overwrite existing mix data until transitioning at their respective **Write To:** locations. Even though previous Mix Passes are retained, for efficient operation care should be taken when using these functions.

Setting a Fixed End Time

Fixed **End** Times are set using the **Write To End Time** pull-down menu in the AutoTouchPlus window of the GC. The pull-down menu will allow the selection of an End Time definition (End of Mix, End of Time, or Fixed...).

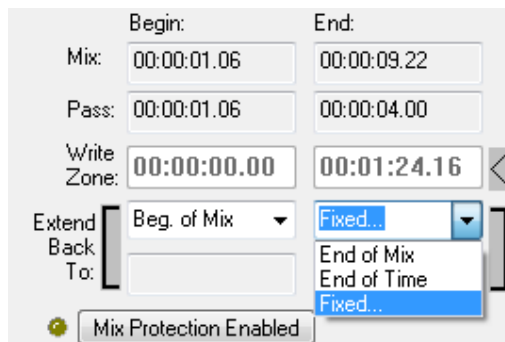

The **End of Mix** time is predetermined by the End Time of the Active Mix Pass and cannot be altered via this field. **End of Time** is always the last possible timecode location (i.e. 23:59:59.2X) and cannot be altered. When **Fixed End Time** is selected a T.C. (timecode) entry box appears.

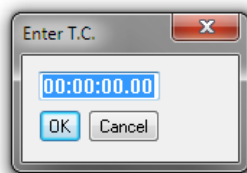

The desired **Fixed End Time** may be entered via this box by typing in a timecode location or using the click-and-scroll method (timecode locations cannot be pasted into this field) and clicking **OK**. When **Fixed End Time** is selected, the entered timecode location will be shown in the display field directly below the **End Time** pull-down menu. Changes or direct entries are not allowed using this field. To edit the **Fixed End Time**, **Fixed** must be selected from the pull-down menu.

Right-clicking in the **Enter T.C.** field will open the Entry Field Right-click menu. This menu contains several items that assist the user in quickly entering timecode values.

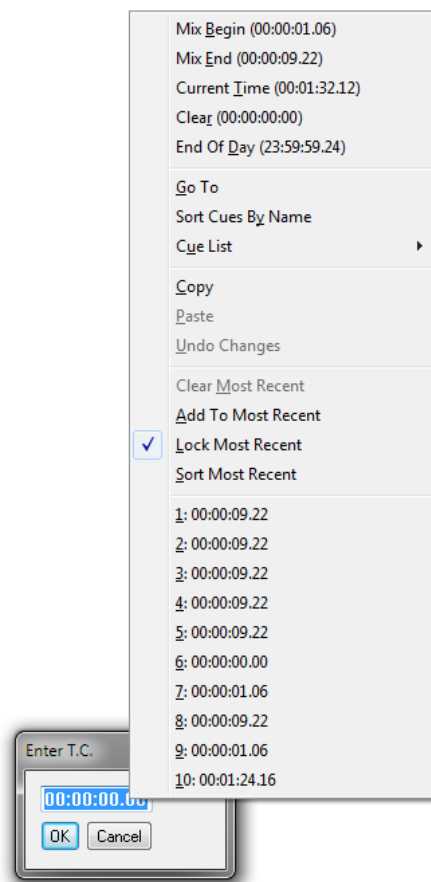

These items are organized in five basic areas:

- Significant System Times: Mix Begin, Mix End, Current Time, Clear (00:00:00.00), and End of Day (23:59:59.23)
- Cue List Times: Allows access to the Title Cue List and provides the means to sort and go to cues
- Copy/Paste/Undo Changes: Entry field clipboard functions
- Most Recent: A list of the most recently used timecode locations is maintained by the system. Timecode locations from this list may be selected for the entry field value. The most recent timecode (current value) may be locked as the entry field value, to prevent it from being changed. A timecode may be manually added to the list. The list may be sorted and deleted.

Hot Keys Hot Keys are provided to aid in the entry of fixed End timecode locations. A complete description of Hot Key functions is provided in [chapter 5.24](#).

<Option> **<End of Pass Clears>**: The End of Pass options (also refer to [chapter 5.22.6](#)) determine the behavior of specific functions when a mix pass is terminated by stopping timecode. The behaviors that take place are determined in the End of Pass Options page. Check boxes allow the selection of the following options:

With **<Write To End>** checked, the **Write To: End** function is disabled after the end of every Mix Pass and Punch Out is reset as the default state. This ensures that **Write To: End** is only used for one pass without being reset as the **Write To:** function.

5.10.2 Extend Back To:

The choice of Mix Pass Extend Back To: function determines where the Read Mix Data-to-Record Data transition takes place. In essence, the concept is as follows:

‘Take the last recorded value and extend it back to: _____!’

The blank can be filled in with one of two Extend Back To: locations:

- **Punch In:** Extend the Last Recorded Value back to the punch in location
- **Begin:** Extend the Last Recorded Value back to the specified Begin Time. These locations are also known as Extend Back To: Functions.

Note

Unlike other automation systems, the transition from Read Mix Data to Record

Extend Back To: buttons

The Mix Pass Extend Back To: buttons determine the point at which the transition from Read Mix Data to Record Data will take place. As noted above, there are two different Extend Back To: functions. The selected function button will illuminate when that Extend Back To: function is active. Only one function can be active at a time.

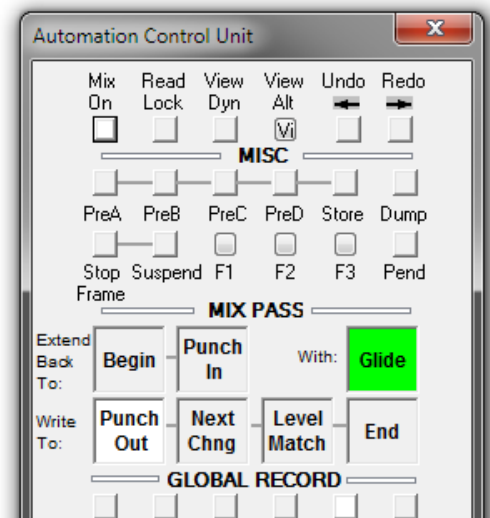

Buttons for Extend Back To: functions are located in the Mix Pass section of the ACU window.

The two Extend Back To: functions behave as follows:

- **Punch In:** The Last Recorded Value (typically the value at the time of the punch out) will be extended back to the punch in point. At the punch in point, the Read Mix Data will transition to the Record Data.
- **Begin:** The Last Recorded Value will be extended back to the user-specified Begin Time. All previously recorded values between the Last Recorded Value (typically Punch out) and the Begin Time will be erased. The Begin Time is defined in three different ways:
 - Beginning of Mix: The Last Recorded Value will be extended back to the Begin Time of the Active Mix.
 - Beginning of Time: The Last Recorded Value will be extended back to the first possible timecode location (i.e. 00:00:00.00).
 - Fixed...: The Last Recorded Value will be extended back to a ‘fixed’ user-specified Begin Time. See Setting a Fixed Begin Time below.

Post Pass Processing By definition, **Extend Back To:** transitions are performed as a post pass process. This also means it is possible to overwrite mix data in locations that have not been heard. Care is suggested while using **Extend Back To:** functions.

Important Note **Extend Back To: Punch In** and **Begin** are destructive functions in the regard that they will overwrite existing mix data back to their respective **Extend Back To:** locations. Even though previous Mix Passes are retained, for efficient operation care should be taken when using these functions.

Setting a Fixed Begin Time Fixed Begin Times are set using the methods employed to setting Fixed End Times. Refer to ‘Setting a Fixed End Time’ in [chapter 5.10.1](#) above.

Hot Keys Hot Keys are provided to aid in the entry of fixed Begin timecode locations. A complete description of Hot Key functions is provided in [chapter 5.24](#).

- <Option>**
- **<End of Pass Clears>**: The End of Pass options (refer to [chapter 5.22.6](#)) determine the behavior of specific functions when a mix pass is terminated by stopping timecode. The behaviors that take place are determined in the End of Pass Options page. Check boxes allow the selection of the following options:
 - With **<Extend Back To Begin>** checked, the **Extend Back To: Begin** function is disabled after the end of every Mix Pass. This ensures that **Extend Back To: Begin** is only used for one pass without being reset.
 - With **<Extend Back To PUNCH-IN>** checked, the **Extend Back To: Punch In** function is disabled after the end of every Mix Pass. This ensures that **Extend Back To: Begin** is only used for one pass without being reset.
 - With **<Extend Back To PUNCH-IN Selects Write to Punch Out>** checked in the Master Panel Options page (refer to [chapter 5.22.5](#)), **Write To: Punch Out** is automatically selected when **Extend Back To: Punch In** is selected. This is convenient since these functions are often used together, especially when Auditioning a level and then using that level between punch in and punch out locations.
 - The ACU window **Extend Back To: Punch In** and **Begin** buttons may be overridden by checking options in the **<Master Panel Overrides>** section of the Master Panel Options page. Faders and Encoders can have **Extend Back To: Punch In** and/or **Begin** set to **<OFF>** or to follow the ACU window **<Follows Panel>**. **Extend Back To: Punch In** and/or **Begin** for Switches can also be set to **<OFF>** or be set to follow the ACU window **<Follows Panel>**.

5.10.3 Glide

AutoTouchPlus provides extensive **Glide** functions. Glide determines how the new data transitions to old data and vice versa. The behavior of the **Glide** functions are determined by the specified Glide Time and the enabled Glide options.

Glide allows Record Data to transition to and/or from Read Mix Data over a user-specified period of time. Controls can ‘glide’ from their Record values back to their Read Mix values at the desired Write To: location. Unlike many other automation systems, controls can also Glide from the Read Mix value to the Record values at the desired Extend Back To: location.

Real-time/Post Process Glides

Glide operations may take place in real-time or as a post Record pass process. Refer to the Write To: or Extend Back To: paragraphs above.

Glide functions are engaged by clicking the **Glide** button in the Mix Pass section of the ACU window. When Glide is active the **Glide** button will illuminate.

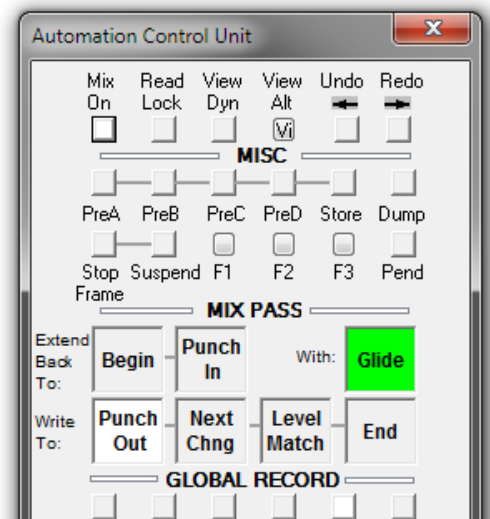

Note If no Glide Options are selected in the Glide Options page, then no glide functions will take place within the system even if the **Glide** button is active.

Glide Behaviors

Glide can be set to operate before or after the Write To: transition points <Option>. **Glide** will always operate after the Extend Back To: transition points when enabled.

Glide behaviors at transition points are described below:

- **Glide** After Transition Point:
 - Write To: At the Record Data-to-Read Mix Data transition, Glide functions will start at the transition point and continue until the Read Mix Data values have been restored. Glide will take place after the Punch out, Next Change or Fixed End location (if possible).
 - Extend Back To: At the Read Mix Data-to-Record Data transition, Glide functions will start at the transition point and continue until the Record Data values have been reached. The **Glide** will take place after the **Punch In** or **Begin** location.

- **Glide Before Transition Point (Back Time enabled <Option>):** This feature is only available for **Write To:** data transitions and at the end of the Write Zone when AutoPunch is used.
 - **Write To:** At the Record Data-to-Read Mix Data transition, **Glide** functions will start before the transition point by the amount of the Glide Time. The Glide will continue until the Read Mix Data values have been restored (at the specified transition point). The Glide operation will be completed by the Next Change or End location. For example, if a three second Glide is applied with ‘back time’ enabled, the control will start gliding back to its Read Mix data three seconds before its **Write To:** transition point.

Setting the Glide Time

The Glide Time period of time it takes for controls to glide from their Record values to their Read Mix values. This time can be any value between 00:00:00.00 and 23:59:59.2x and is specified via the Glide Time entry field in the AutoTouchPlus window on the GC. Glide times can be typed in or entered using the click-and-scroll method.

Right-clicking the Glide Time entry field will open the Entry Field Right-click menu. This menu contains several items that assist the user in quickly entering timecode values.

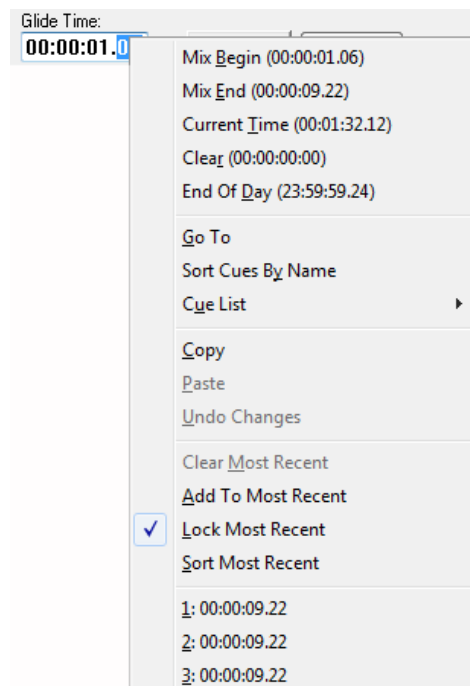

- **Significant System Times:** Mix Begin, Mix End, Current Time, Clear (00:00:00.00), and End of Day (23:59:59.23)
- **Cue List Times:** Allows access to the Title Cue List and provides the means to sort and go to cues
- **Copy/Paste/Undo Changes:** Entry field clipboard functions
- **Most Recent:** A list of the most recently used timecode locations is maintained by the system. Timecode locations from this list many be selected for the entry field value. The most recent timecode (current value) may be locked as the entry field value, to prevent it from being changed. A timecode may be manually added to the list. The list may be sorted and deleted.

- Hot Keys** Hot Keys are provided to aid in the entry of glide times. A complete description of Hot Key functions is provided in [chapter 5.24](#).
- <Option>** Glide can be applied to all transition points used within the system. The affected points are selected by checking the options in the Glide Options page (also refer to [chapter 5.22.3](#)).
- <Apply Glide to the following transition points when Glide is ON:>
- <Write To:> Glide will be applied to the following Write To: transition points:
 - <Punch Out>
 - <Next Change>
 - <End>
 - <Write Zone End (Auto Punch Out)>
 - <Extend Back To:> Glide will be applied to the following Extend Back To: transition points:
 - <Begin>
 - <PUNCH-IN>
 - <Back Time Glide (End and Write Zone End Only)>: Glide will ‘back time’ from the transition point. The Glide will start before the transition point by the amount of the Glide Time. The Glide will finish at the transition point. This feature does not apply to Extend Back To: transition points.

5.11 Switch Automation

Switch automation using AutoTouchPlus is both easy to use and flexible enough to facilitate numerous functions and modes of operation.

Real-time Switch Editing

The location of switch state changes may be edited in real-time. Adding or deleting switch events may also be easily accomplished.

In general, the following types of switch events may be created and edited:

- Mute On/Off: Turns the channel Mute on and off
- Process In/Out: Engages and disengages the configured processes
- Process Control Switches: Performs switch functions within configured processes

Note: Channel Mute operates within AutoTouchPlus as a switch, but since it has its own Status key, some Mute functions are performed differently as other switches. These differences in operation will be noted where needed.

Other system controls that are seen by AutoTouchPlus as ‘switches’ but have alternative means of control. These controls are discussed in detail elsewhere in this document, but warrant mention here:



- Selectors: Choosing the routing of audio or audio processor functions (Channel Input Selector or Filter Slope for example). See below.
 - General Patch Connections: Making or breaking General Patch Connections. Refer to [chapter 5.12.1](#), General Patch.
 - Channel Patch Direct Out Tap: Changing the location from where the channel Direct Output is derived. Refer to [chapter 5.12.2](#), Channel Patch.
 - Channel Patch Meter Tap: Changing the location from where the channel Meter feed is derived. Refer to [chapter 5.12.2](#), Channel Patch.
 - Channel Patch Processor Order: Changing the location of processor blocks within the channel. Refer to [chapter 5.12.2](#), Channel Patch.
- <Option>**
- With <Read Safe> checked in the Misc Options page (refer to [chapter 5.22.7](#)), AUDITION mode is defeated for controls in READ and only Read Mix values will be heard.

5.11.1 Switch Classifications

The multiple switches on the channel strip can be defined as being either VMC oriented or control oriented. The classification of the switches (and other controls) is determined by whether or not they are defined in VMC file. If they are not defined by the VMC, they are control oriented by default.

- VMC-oriented controls: By definition, the objects (controls in this case) that appear in the VMC are audio oriented. These objects directly affect the audio and/or its routing.
- Control-oriented controls: By definition, these controls have an operational orientation and do not directly affect audio. These controls perform system oriented functions.

- VMC Switches** VMC oriented switches can be automated using AutoTouchPlus. These switches are as follows:
- **MUTE**: Channel Mute
 - Encoder Parameter Switches: The switch associated with each of the four channel strip rotary encoders.
 - Rotary Selectors: This also includes rotary encoders that are used as Selectors. (See ‘Selectors’ below)
 - Processor Block In/Out Switches: **HI CUT, LO CUT, DELAY, INS, COMP-LIMIT, EXP-GATE, EQ, PAN**
 - Auxiliary In/Out Switches: **AUX MONO 1..., AUX STEREO 1...**
 - Input Selector Switches (See ‘Selectors’ below): **IN 1, IN 2, GEN**

- Control Switches** Switches that are control-oriented are outside the AutoTouchPlus system and therefore cannot be automated. Switches outside of the control of AutoTouchPlus are as follows:
- **LINK / SEL** Key: Channel select key
 - **PFL/SOLO** key
 - Layer switch: **L2**
 - Clipboard Control Switches: **CLR**,  (Copy/Paste),  **A** (Copy/Paste All)
 - **TALK**
 - User Key: **USR 1**

- Selectors** Selectors are a special group of controls that typically use the encoder knobs as a means of physical control, but function as ‘switches’ within AutoTouchPlus. This differs from switches that operate as ‘toggles’, alternating between two states only.

Selectors perform one of two functions:

- Audio Routing: Input Selector, Direct Out tap location, Meter tap location, Processor Block Order, etc.
- Processor Parameter Selector: Input Function, Filter Slope, etc.

Selectors may be assigned to switches, knobs, or to the Channel Patch for a means of control. However, they may only be preselected using the **SW** preselectors.

- Notes:** The Channel Input Selector is a special case in regard that it has a key for each input on the channel strip. However, these keys function collectively as a Selector. The input may also be selected from the Channel Patch.

5.11.2 Switch Control Modes

Since switches and selectors are not continuous controllers like faders or encoders, Control Modes affect switches in a unique manner.

Switch operations will perform the following functions when dynamic switches are in the Control Modes indicated:

READ The Read Mix data will determine the switch state. AUDITION mode is available.

- Press and Release Actuation:
 - Without **TOUCH – Hold** engaged, Switch Press will toggle the switch state and put the switch in Audition. The switch state will toggle back at the next recorded change of state.
 - With **TOUCH – Hold** engaged, Switch Press will toggle the switch state and put the switch in Audition in a Held state. The switch will hold its alternate state and stay in Audition until Held controls are cleared.
- Press and Hold Actuation:
 - Switch Press will toggle the switch state and put the switch in Audition. The switch will exit Audition when released. If its state does not match the Read Mix state, it will toggle to match upon release.

WRITE While in RECORD previously written switch states will be overwritten. WRITE AUDITION mode is available.

- Press and Release Actuation:
 - Without **TOUCH – Record** or **TOUCH – Hold** engaged, Switch Press will toggle the switch state and put the switch in Audition. The switch state will toggle back at the next recorded change of state.
 - With **TOUCH – Hold** engaged, Switch Press will toggle the switch state and put the switch in Audition in a Held state. The switch will stay in Audition until Held controls are cleared.
 - With **TOUCH – Record** engaged, Switch Press will toggle the switch state and punch the switch into RECORD. The switch will hold its alternate state and stay in RECORD until Held controls are cleared.
- Press and Hold Actuation:
 - Without **TOUCH – Record**, Switch Press will toggle the switch state and put the switch in Audition. The switch will exit Audition when released. If its state does not match the Read Mix state, it will toggle to match upon release.

- With **TOUCH – Record** engaged, Switch Press will toggle the switch state and punch the switch into RECORD. The switch will punch-out when released. If its state does not match the Read Mix state, it will toggle to match upon release.

TRIM While in TRIM previously written switch states may be edited. TRIM AUDITION mode is available.

- Press and Release Actuation:
 - Without **TOUCH – Record** engaged, Switch Press will toggle the switch state and put the switch in Audition. The switch state will toggle back at the next recorded change of state.
 - With **TOUCH – Record** engaged, Switch Press will toggle the switch state and punch the switch into RECORD. The switch will hold its alternate state and stay in RECORD until the next recorded change of state. The switch state will toggle to its Read Mix state and will punch-out at the next recorded change of state.
- Press and Hold Actuation:
 - Using Press and Hold actuation on **Trim Enabled** switches yields the same results as if the switches were **Write Enabled**.

The Trim of a switch cannot persist past the next recorded change of state for that switch.

ISOLATE State changes of Isolated switches are not recognized by AutoTouchPlus.

Note All Mix Pass Write To: and Extend Back To: conditions apply as appropriate.

5.11.3 Switch Operation

Switches and Touch-sensitivity Switches are not ‘touch-sensitive’ in the same regard as faders or encoders. Mere physical contact with a switch is not sufficient enough to be registered by the system. For switches to have an effect within the system, they must be pressed.

Unlike faders and encoders (knobs) switches are ‘touch-sensitive’ only when engaged and disengaged. Because of this, and the toggle function of most switches (all switches except Selectors), the automation of switch functions differs from faders and encoders. The differences are operational mostly in nature and will be described in this chapter.

Switch Functions Pressing a switch performs two basic functions:

- Audio Function: The switch state is toggled to its alternate position.
- Automation Functions:
 - Switch Press
 - Switch Release

Under normal circumstances, a Switch Press produces a Touch event. However, unlike faders and encoders, switches do not produce a Un-touch event when they are released. The Switch Press audio toggle (switch state toggle) event may be suppressed by holding down the ISO (AUTO MODE) modifier key when the switch is actuated.

AutoTouchPlus recognizes Switch Press and Switch Release as separate and independent events. The Touch event produced by a Switch Press serves a separate from the Switch Press itself. This system allows the user to determine what will take place when a key is pressed and also when it is released.

This independence allows switches to take on different behaviors depending on which functions Switch Press and Switch Release are allowed to perform. The result is the ability for switches to operate in different modes depending on the needs of the user.

Switch Operating Modes

Switches may operated using the following modes:

- Press and Release: Momentary Press and Release; Pressing the key and immediately releasing it.
- Press and Hold: Pressing and holding the key down beyond a predetermined time threshold.
- Modified Press Function: Holding the ISO (AUTO MODE) key will suppress the audio toggle function, but produces the Touch event when a key is pressed. This mode allows the switch to be punched-in without toggling its state.

Each of these functions are described below. The Modified Press Function may be used with either Press and Release or Press and Hold operations.

***Document Note** The next three chapters make the assumption that the switches actuated are in the proper enabled Control Mode as operations are carried out.*

5.11.3.1 Press and Release

Press and Release is defined as using switches in a momentary manner. To perform a Press and Release operation, press a desk key and immediately release it. The key is not held down any longer than it takes to toggle the switch state.

Press and Release operations perform the following functions:

- Switch Press:
 - Toggles the switch state
 - Produces a Touch event
- Switch Release:
 - An Un-touch event is not produced.

With Press and Release operations, switches toggle to their alternate state when pressed and then hold that state until one of several conditions is met. The behaviors that occur as the result of a Press and Release switch operation is depending on the switch's Control Mode and whether **TOUCH – Record** and/or **TOUCH – Hold** is engaged. Refer to [chapter 5.11.2](#).

Note If a switch is held down too long, it will change to Press and Hold operation. The length of time a switch may be held down is determined by the Switch Press and Hold Threshold in the `D950desk.ini` file in the `D950System` folder.

5.11.3.2 Press and Hold

Press and Hold is defined as using switches in a temporarily sustained manner. To perform a Press and Hold operation, press a switch and hold it down for a period of time before releasing it. AutoTouchPlus senses how long the key is down and its mode of operation changes if it is held down longer than a specified period of time (typically 500 ms or so). The function becomes similar to touching a fader, keeping a finger on it, and then releasing it later.

Press and Hold operations perform the following functions:

- Switch Press:
 - Toggles the switch state
 - Produces a Touch event
- Switch Release:
 - Punch-out

With Press and Hold operations, switches toggle to their alternate state when pressed and then hold that state as long as the key is held down. When the switch is released, it may or may not toggle depending on the state recorded in the Read Mix Data at the time of release.

If **TOUCH – Record** is engaged, the switch will punch-in as well as toggle its alternate state when it is pressed. The switch will stay in that state and in RECORD as long as the switch is held down. Upon release, the switch will punch-out. It may or may not toggle states depending on the state recorded in the Read Mix Data at the time of release. The change of state may be Written or Trimmed depending on the selected Control Mode.

The behaviors that occur as the result of a Press and Hold switch operation is depending on the switch's Control Mode and whether **TOUCH – Record** and/or **TOUCH – Hold** is engaged. Refer to [chapter 5.11.2](#), Switch Control Modes.

Press and Hold Threshold

Whenever a desk key is pressed, AutoTouchPlus monitors the duration the key is held down. If the time a key is held down is longer than the Switch Press and Hold Threshold value, Press and Hold becomes active. If the hold duration is less than the threshold time the Press and Release functions are maintained.

5.11.3.3 Modified Press Function

It is possible to suppress the toggle function when a switch is pressed, but still allow the Touch event to be produced. This allows a punch-in or Audition to be performed by pressing a switch without toggling its state. This 'Modified Press Function' is very useful when the punch-in switch state matches the Read Mix state.

This Modified Press Function is available for both Press and Release and Press and Hold operations.

The key press may be modified by holding the ISO (AUTO MODE) key while a desk key is pressed. In this regard, the ISO (AUTO MODE) key functions as a modifier key.



Example With **TOUCH – Record** engaged, press and hold the **ISO (AUTO MODE)** key, then press and hold a record-enabled key. When the key is pressed, it will punch-in but its status will not toggle. If the **ISO (AUTO MODE)** key is released before the key is, toggle suppression is turned off. Now when the key is released, it will toggle its status, and the key release will cause the control to punch-out.

5.12 Graphical Controller Automation

As discussed in the Switch Automation chapter, controls that are defined in the VMC may be automated. While most of these controls are desk oriented, some controls are found only in the Graphical Controller.

Automated Items Automatable items in the Graphical Controller are as follows:

- General Patch Connections
- Channel Patch:
 - Input Selector
 - Processor Block Order
 - Dynamic Sidechain Link Setup
 - Dynamic Sidechain Link Enable
 - Dynamic Key Input Routing
 - Direct Output Tap Location
 - Meter Feed Tap Location

5.12.1 General Patch

Connections within the General Patch may be automated. Both ‘Make Connection’ and ‘Break Connection’ operations may be stored as Static objects or recorded as Dynamic objects. All types of General Patch connections may be recorded.

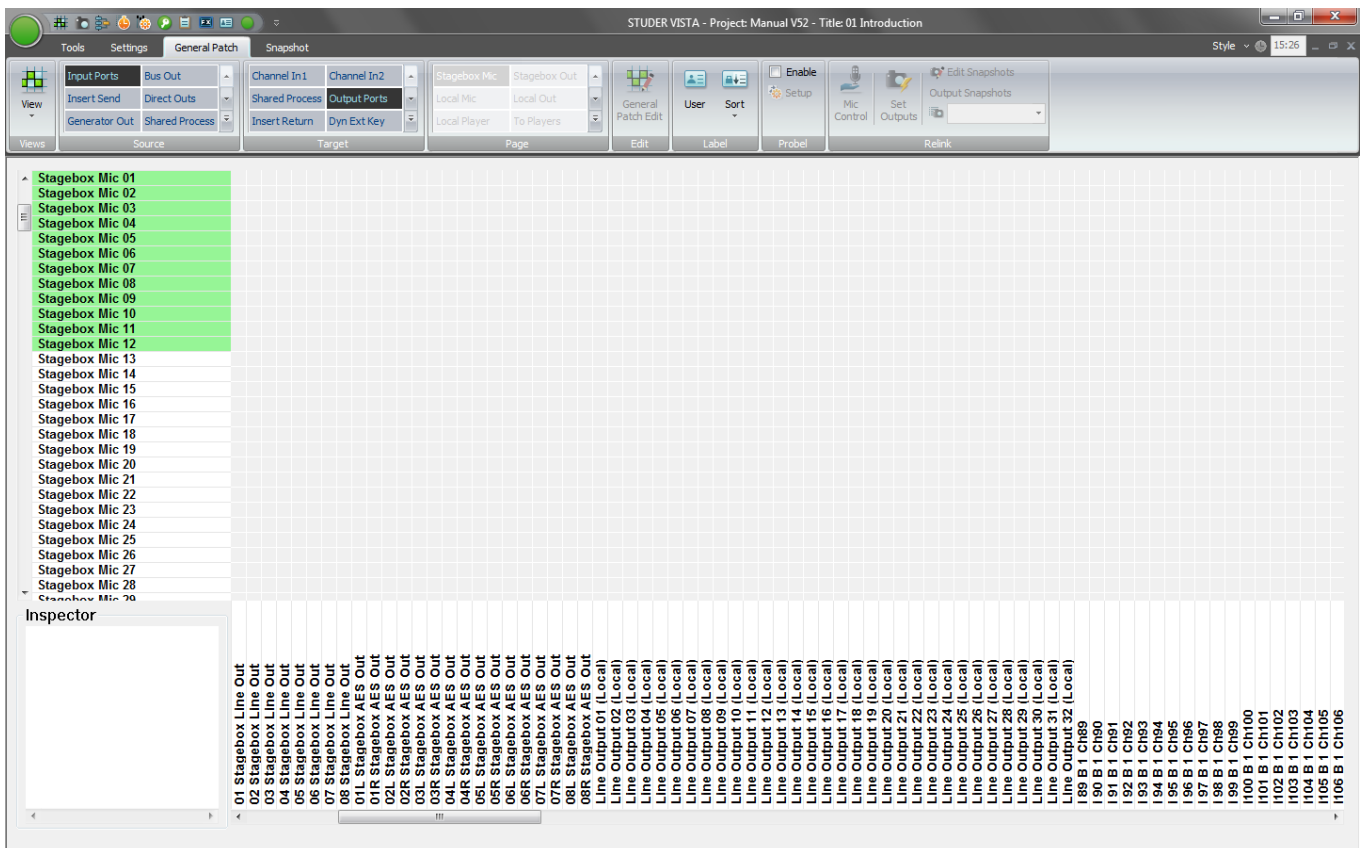

Connection Behavior

The General Patch does not have dedicated automation controls. The current global automation modes apply to the General Patch. The SW preselector must be used to select global modes. General Patch connections follow the rules of a Press and Release switch operation. Refer to [chapter 5.11.3.1](#).

As with any control, changes to General Patch connections may be Auditioned.

Record a General Patch Change

To automate a connection in the General Patch, use the following procedure:

1. Select the desired global Control Mode. **Write** will overwrite previous changes, both location and connection type.
2. Select **TOUCH – Record**.
3. Select the desired Write To: and Extend Back To: functions.
4. Open the General Patch if it is not already open.
5. Select the connection point to be automated (single click at the desired location).
6. Make/break the desired connection as follows:
 - To make a simple mono-to-mono connection, press the **MAKE CONNECT** function key above the trackball. (Double-clicking the connection location will bring up the connection menu where a mono-to-mono connection may be made.)
 - To make a complex connection (mono-to-stereo, stereo-to-stereo, stereo-to-mono), double-clicking the connection location will bring up the connection menu where the desired connection may be made.
 - To break any connection, press the **BREAK CONNECT** function key above the trackball. (Double-clicking the connection location will bring up the connection menu where a connection may be broken.)
7. Upon the selection of the desired connection type, AutoTouchPlus will punch-in. Following the rules for Press and Hold, the new connection state will persist until the Write To: conditions are met or a Global Punch-out occurs.
8. When timecode is stopped, a new Mix Pass will be generated.

Note Like any other object within AutoTouchPlus, all General Patch connection points are Static objects until a change state is recorded in the system. Therefore, General Patch connections may be updated in the same manner as any other Static control.

5.12.2 Channel Patch

There are several items within the Channel Patch that may be automated. These items may be stored as Static objects or recorded as Dynamic objects.

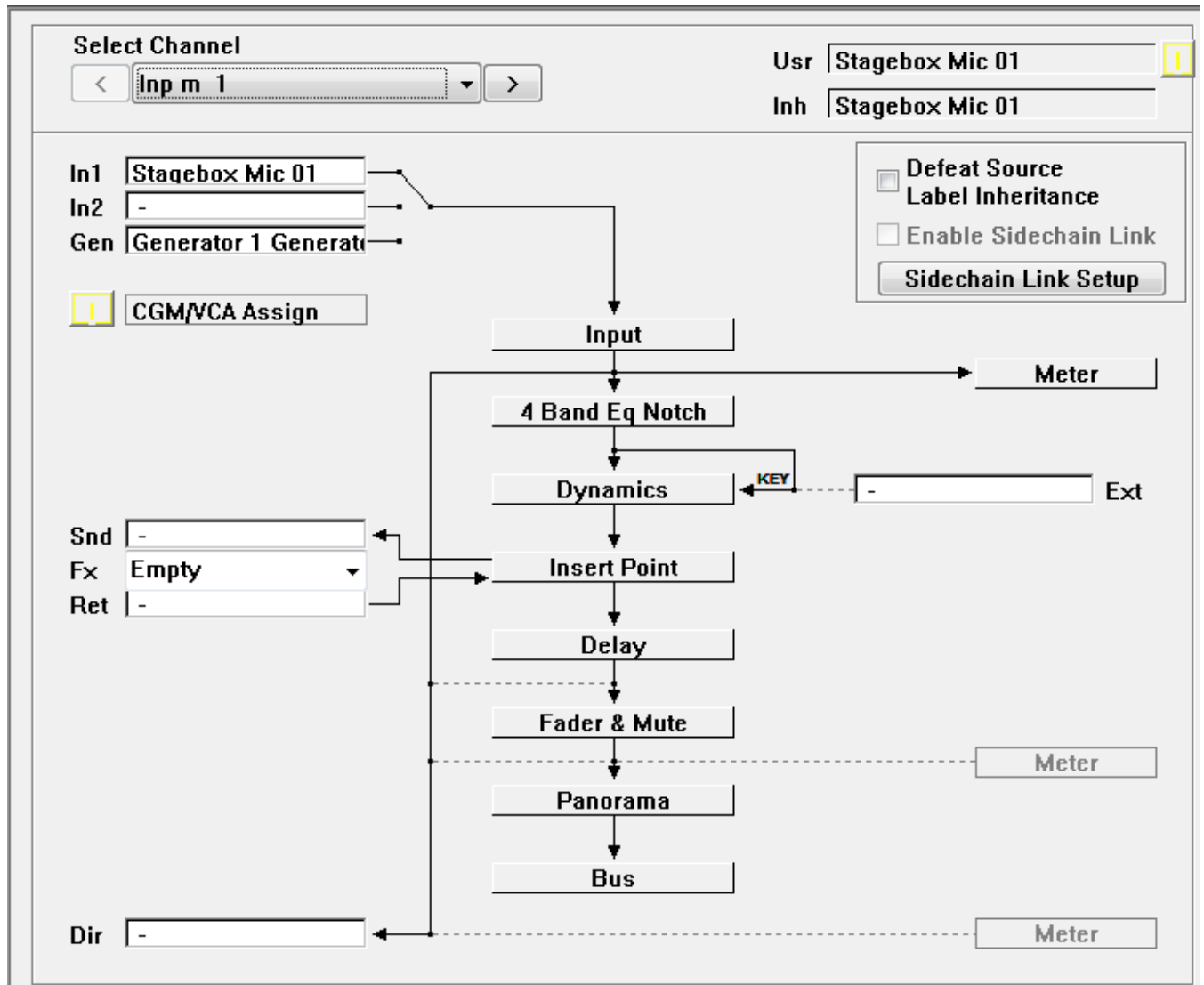

The following Channel Patch items may be automated:

- Input Selector: Changes to the selected channel input may be automated (In1, In2, Gen)
- Processor Block Order: Changes to the order of the channel processor blocks may be automated (EQ, Dynamics, Insert, Delay, and Fader)
- Dynamic Sidechain Link Setup: The addition of channels to the Dynamic Sidechain Link Setup may be automated
- Dynamic Sidechain Link Enable: The 'Enable Sidechain Link' button may be automated (Enable/Disable)
- Dynamic Key Input Routing: The selection of the Dynamic unit Key Input may be automated (Channel/External)
- Direct Output Tap Location: The location from where the channel Direct Output is fed may be automated (Post Input, Pre Fader, Post Fader)
- Meter Feed Tap Location: The location from where the channel Meter is fed may be automated (Post Input, Post Fader, Direct OutAssignment)

Notes Like any other object within AutoTouchPlus, all Channel Patch items are

Static objects until a change state is recorded in the system. Therefore, Channel Patch items may be updated in the same manner as any other Static control.

The following Channel Patch items have switches on the channel strip that duplicate the Channel Patch functions:

- Input Selector
- Dynamic Sidechain Link Enable
- Dynamic Key Input Routing

The channel Meter location can be set globally using the controls in the ‘Meter/Generator’ item in the GC Options menu (not the AutoTouchPlus Options selector).

Item Behavior The Channel Patch does not have dedicated automation controls. The current global automation modes apply to the Channel Patch.

The following Channel Patch items operate as Selectors:

- Input Selector
- Processor Block Order
- Dynamic Key Input Routing
- Direct Output Tap Location
- Meter Feed Tap Location

The SW (SW) preselectors are used to select global modes.

Press and Release Selectors Some Channel Patch Selectors operate as Press and Release switches and therefore follow Press and Release switch operation rules. Refer to [chapter 5.11.3.1](#).

The following Channel Patch items operate as Press and Release Selectors:

- Input Selector
- Dynamic Key Input Routing
- Meter Feed Tap Location

Note The channel Input Selector may be operated via the Channel Patch or by using the keys on the channel strip. Since input selection is controlled with a Selector, Press and Hold operations are not possible.

One Shot Selectors Other Channel Patch Selectors operate as ‘One Shot’ switches. One Shot selectors operate as true momentary switches. The user has no control over the duration of the held down state and release is immediate. A One Shot operation produces both a Touch and a Un-touch event. In **TOUCH – Record**, when a One Shot switch is operated, punch-in and punch-out is almost immediate. Under normal circumstances this could produce an audible glitch, depending on the operation being completed. However, functions assigned to One Shot Selectors will persist in their changed state after punch-out. All Mix Pass Write To: and Extend Back To: conditions apply, except ‘Write To : Punch Out.’

The following Channel Patch items operate as One Shot Selectors:

- Processor Block Order
- Direct Output Tap Location

These items follow the rules for One Shot Selectors as described above.

- Channel Patch Operations** Channel Patch items are operated as follows:
- **Input Selector:** Place the cursor on or near the Input Selector icon. Each trackball click will cycle the selector through the inputs. A Touch event will be produced for each click.
 - **Processor Block Order:** Click and hold the processor block to be moved, drag it to the new location, and release the trackball button (click and drag). A Touch event will be produced when the trackball is released.
 - **Dynamic Sidechain Link Setup:** Clicking Sidechain Link Setup will open the Sidechain Link window where channels may be added to the available Sidechain Links. A Touch event will be produced when the 'ADD' button is clicked.
 - **Dynamic Sidechain Link Enable:** Clicking the Check Box will toggle the switch state. A Touch event will be produced when the box is checked or unchecked.
 - **Dynamic Key Input Routing:** The route with the solid line is the current state. Clicking the dashed line will select that route and a Touch event will be produced.
 - **Direct Output Tap Location:** The route with the solid line is the current state. Clicking the dashed line will select that route and a Touch event will be produced.
 - **Meter Feed Tap Location:** Clicking the alternate location (shown grayed-out) will select that location and a Touch event will be produced.

- Channel Patch Switches** Two Channel Patch items operate as toggle Switches:
- Dynamic Sidechain Link Setup
 - Dynamic Sidechain Link Enable

From the Channel Patch, these switches follow the rules of Press and Release switch operations. However, if these functions are accessed via the channel strip keys, they may use either Press and Release or Press and Hold operations. Press and Hold functions are not available via the GC.

As with any control, changes to Channel Patch items may be Auditioned.

- Record a Channel Patch Change** To automate an item in the Channel Patch, use the following procedure:
1. Select the desired global Control Mode. **Write** will overwrite previous changes, both location and connection type.
 2. Select **TOUCH – Record**.
 3. Select the desired **Write To:** and **Extend Back To:** functions.
 4. Open the Channel Patch if it is not already open.
 5. Perform the desired operation within the Channel Patch.
 6. At the time the desired operation is performed, AutoTouchPlus will punch-in. The new item state will persist until the **Write To:** conditions are met or a Global Punch-out occurs.
 7. When timecode is stopped, a new Mix Pass will be generated.

5.13 Other Automated Functions

There are several ancillary functions that may be automated. These functions are described below.

5.13.1 Bus Assignments

Bus Assignments may be automated. Both 'assignment' and 'de-assignment' operations may be stored as Static objects or recorded as Dynamic objects. Bus Assignments follow the rules of a Press and Release or Press and Hold switch operation. Refer to [chapter 5.11](#). All Mix Pass Write To: and Extend Back To: conditions apply, except 'Write To : Punch Out.'

As with any control, changes to Bus Assignments may Auditioned.

Record a Bus Assignment

To automate a Bus Assignment, use the following procedure:

1. Select the desired global Control Mode. **Write** will overwrite previous changes, both location and connection type.
2. Select **TOUCH – Record**.
3. Select the desired Write To: function.
4. Activate **BUS ASN** in the Touch Screen Area below the Vistonics™ section.
5. Press the desired bus number to make the assignment.
6. Press and Release or Press and Hold switch rules will apply depending on how the switch is operated.
7. When timecode is stopped, a new Mix Pass will be generated.

Note Like any other object within AutoTouchPlus, all Bus Assignments are Static objects until a change state is recorded in the system. Therefore, Bus Assignments may be updated in the same manner as any other Static control.

5.13.2 Snapshots/Presets

VMC Snapshots and Presets may be recalled while AutoTouchPlus is in use. The control values contained within Snapshots and Presets may be applied to the console while AutoTouchPlus is in operation, but only for controls that have been properly enabled. All Mix Pass Write To: and Extend Back To: conditions apply.

Snapshot and Preset control values may be recalled and stored as Static values by recalling the desired Snapshot/Preset without engaging Write or Trim enable. The Static values will be updated and saved the next time a Mix Pass is written.

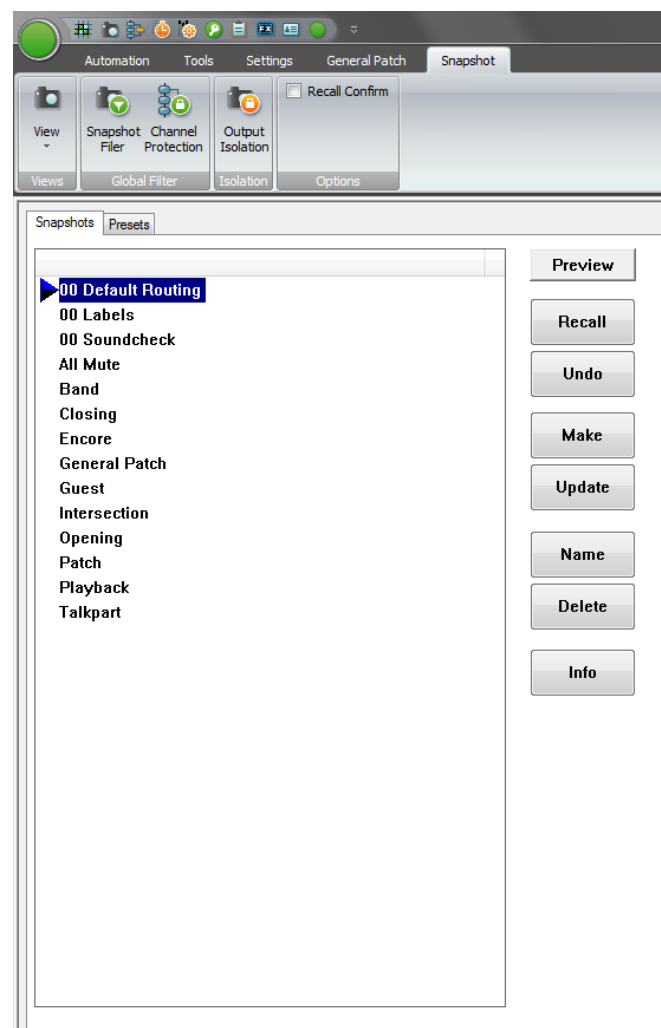

Recall Behavior The Snapshot page does not have dedicated automation controls. The current global automation modes apply when Snapshots or Presets are recalled. Any preselector may be used to select global modes, depending on the controls/functions the user wishes to enable.

Switches and Selectors recalled using Snapshots or Presets will follow the rules of a Press and Release switch operation. Refer to [chapter 5.11.3.1](#).

Since values are being applied to VMC controls, the affects of recalling Snapshots or Presets may be auditioned.

- Record Recalled VMC Values** To record Snapshot or Preset values to controls, use the following procedure:
1. Select the desired global Control Mode.
 2. Select **TOUCH – Record**.
 3. Select the desired Write To: function (Trim will default to ‘Next Change’).
 4. Open the Snapshot page in the GC if it is not already open.
 5. Recall the desired Snapshot or Preset.
 6. Global conditions will apply to the controls that were enabled.
 7. When timecode is stopped, a new Mix Pass will be generated.

Note Recalling the channel strip clipboard has the same affect as recalling a Snapshot or Preset, except values are only applied on one channel at a time. Recording recalled clipboard values may be done as described above.

5.13.3 GC Menu Items

Some operational GC menu items may be automated. During normal operation, these items are found in the GC Option menu. However, since all VMC objects are available in the ShowVMCTree menu (in the SysAdmin menu), these menu items may be automated as well.

- Automatable Option Menu Items** The following Option menu items contain automatable controls:
- Meter/Generator: Global channel Meter locations and Generator parameters may be automated. Changes made to these items will produce Touch/Un-touch events.
 - N–1 Assignments: N–1 Assignments may be automated. Changes made to these assignments will produce Touch/Un-touch events.
 - Control Group Filter: Changes made within each Control Group may be automated. Changes made within a Control Group will produce Touch/Un-touch events.
 - VSP Microphones and Reverb: Changes made Reverb Bus Assignments and Microphone Characteristics (polar pattern and placement) may be automated. Changes made within the VSP Microphones and Reverb menu items will produce Touch/Un-touch events.

Menu Item Behavior The GC menus do not have dedicated automation controls. The current global automation modes apply to the automatable GC menu items. For an Option menu item use either the **Sw** or **Knob** preselectors to select global modes, depending on item to be automated. For ‘ShowVMCTree’ items, any preselector may be used, depending on the controls/functions the user wishes to enable.

Menu item switches and selectors will follow the rules of a Press and Release switch operation, refer to [chapter 5.11.3.1](#). All Mix Pass Write To: and Extend Back To: conditions apply.

As with any control, changes to menu items may be auditioned.

- Record a Menu Item Change** To automate a menu item, use the following procedure:
1. Select the desired global Control Mode. **Write** will overwrite previous changes, both location and connection type. Trim will allow the locations of changes to be moved without changing connection types.
 2. Select **TOUCH – Record**.
 3. Select the desired **Write To:** function.
 4. Open the appropriate GC menu and select the desired item.
 5. Perform desired operations to be automated.
 6. At the time the desired operation is performed, AutoTouchPlus will punch-in. The new item state will persist until the **Write To:** conditions are met or a Global Punch-out occurs. (*trimmed* status will persist until the Next Change by default.)
 7. Upon punch-out a new Mix Pass will be created.

Note Like any other object within AutoTouchPlus, menu items are Static objects until a change state is recorded in the system. Therefore, menu items may be updated in the same manner as any other Static control.

5.14 Mix Protection

Mix Protection allows individual controls or sets of controls to be 'Protected' or locked out from changes. Mix Protection may also be applied to the General Patch.

When Protected, a control is essentially in a 'read only' mode. The Read Mix data for the Active Pass will be heard for all Protected controls. All the READ LOCK conditions apply to Protected controls (just not on a global basis).

Controls and the General Patch may also be isolated from the mix using Mix Protection techniques.

'Mix Protection Enabled' Button

The 'Mix Protection Enabled' button opens the 'Automation Protection' window. The yellow LED symbol to the left of the button illuminates when any controls are in a Protected State. The 'Mix Protection Enabled' button is located in the AutoTouchPlus window.

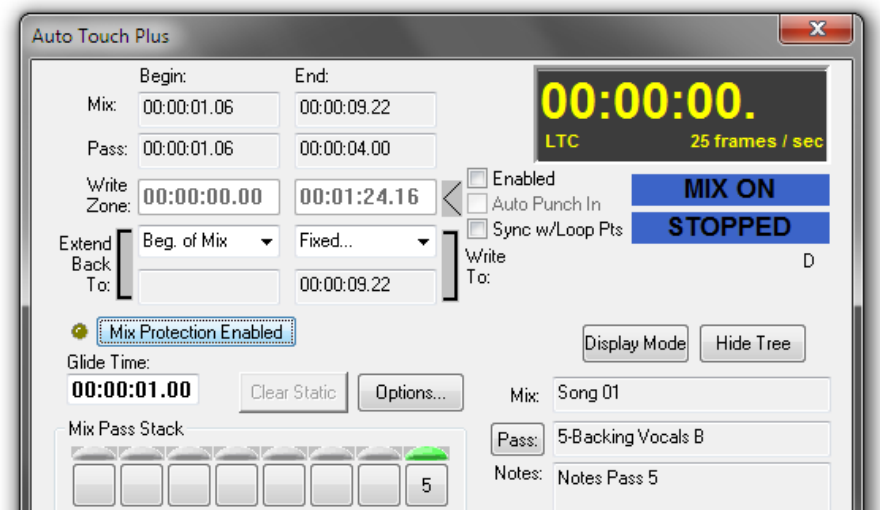

The Automation Protection window can also be opened by selecting 'Protection' from the GC Automation menu.

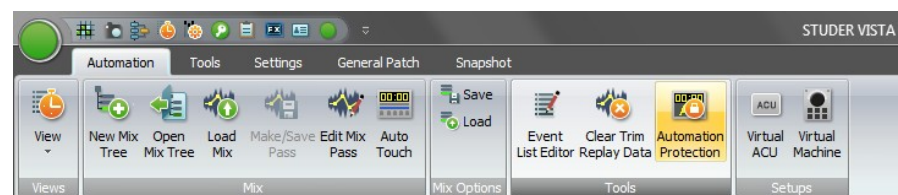

- **<Option>** With <Protect Static For Protected Controls> checked on the Misc Options page (also refer to [chapter 5.22.7](#)), the values of Static controls are replayed, but changes to those values are not allowed.

5.14.1 Protection Sets

Protection Sets Any combination of controls on any combination of channels may be organized into 'Protection Sets.' These may be created, saved, and recalled as needed. Any number of Protection Sets may be created and stored. Protection Sets are available to any Mix Pass within the Title.

5.14.1.1 Creating Protection Sets

To create a Protection set, execute the following procedure:

1. Click the 'Mix Protection Enabled' button to open the 'Automation Protection' window. The first time it is opened no Protection Sets will be available and the various fields will be blank.

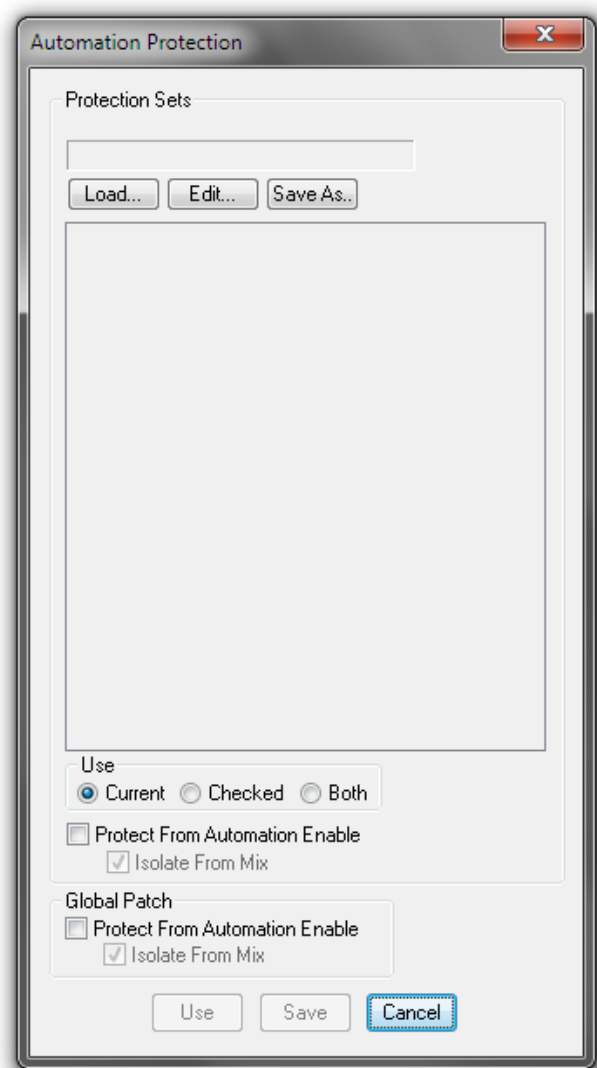

2. Click the 'Edit...' button. The 'Object Picker for Select Objects to be Removed From Automation Scope' will open. Using this picker, controls may be selected for Protection. For example, Mutes on channels 1...12 may be selected as a Protection Set. Refer to [chapter 5.17.2.1](#) for information regarding the operation of the Object Picker.

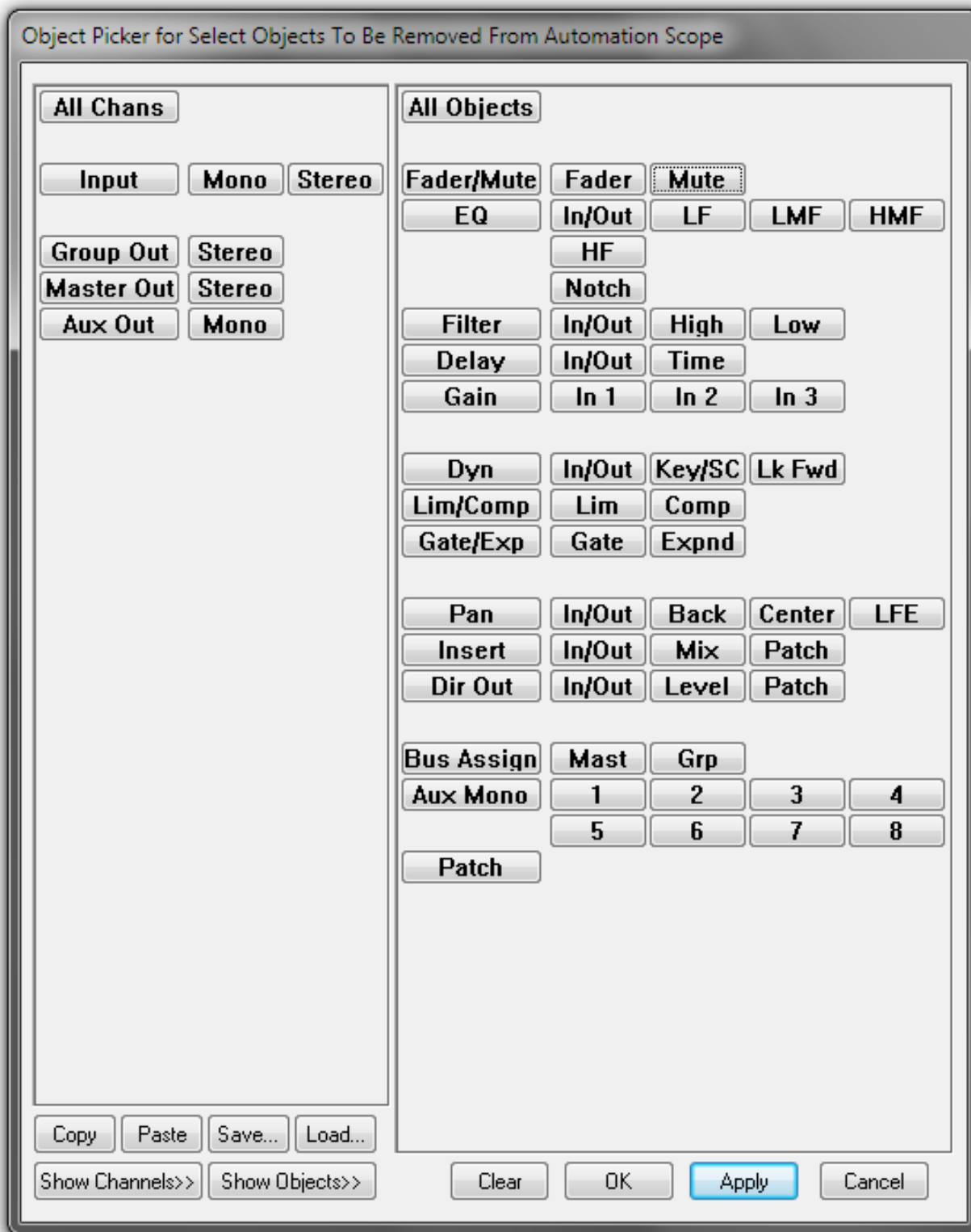

- Once controls have been selected for Protection, click 'Apply' or 'OK' at the bottom of the object picker (OK will close the picker, Apply will keep it open). A temporary Protection Set will be created and made the current set. 'Current Protection Set ****Modified****' will appear in red above the current set field to indicate changes have been made to the current set. (As in the previous example, the Mutes on channels 1-12 would constitute the ****Modified**** set.)

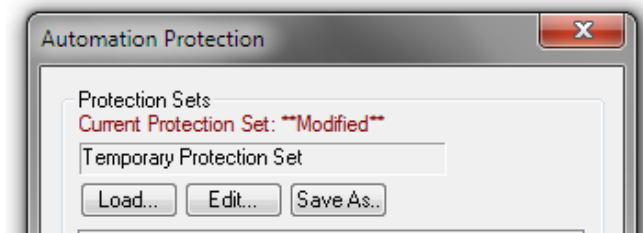

- 4 Check 'Protect From Automation Enable' for the selected set of controls and/or the General Patch. Click the 'USE' button to enable Protection for the selected Protection Set.

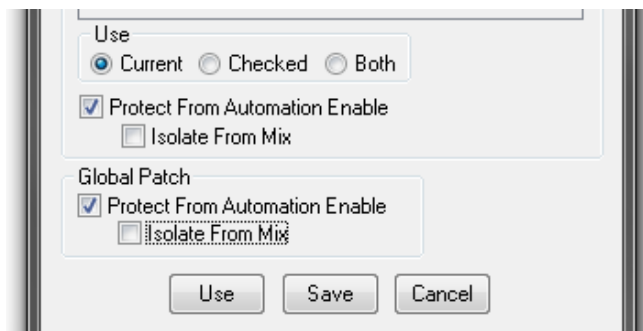

Note Either the 'Current' or 'Both' radio button in the 'Use' section of the Automation Protection window *must* be selected to enable the 'Edit' button.

5.14.1.2 Saving Protection Sets

Any number of Protection Sets may be created and saved. A temporary Protection Set will persist in the system unless it is overwritten, even if the Mix Tree and Title are closed. Temporary and modified sets may be saved at anytime.

Using the following procedure, Protection Sets may be saved:

- 1 Once a Protection Set has been created or modified, click the 'Save As...' button. The Protection Set save box will open.

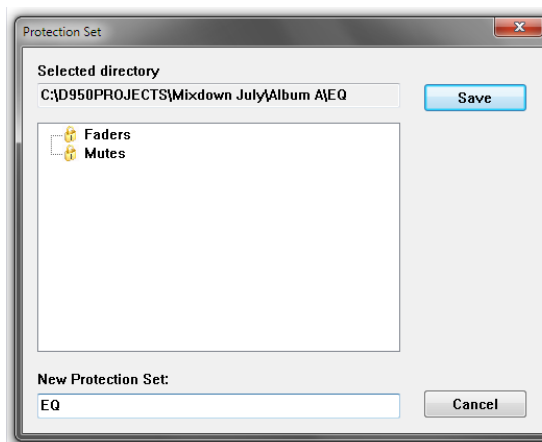

- 2 Enter a name for the new set in the 'New Protection Set:' field. Click 'Save' and the new set will be created and assigned the entered name. The newly saved set will become the current Protection Set and will be added to the list of available sets (which appears in the Protection Set section of the Automation Protection window).

5.14.1.3 Loading Protection Sets

To make a Protection Set the current set, it must be Loaded unless it was the last set used or saved.

Using the following procedure, previously created Protection Sets may be loaded:

1. Click the 'Mix Protection Enabled' button to open the 'Automation Protection' window if it is not already open.
2. Click the 'Load...' button and a selection box containing the available Protection Sets will be displayed. The current Protection Set will be displayed at the bottom of the box in the 'Current Protection Set:' field. The current set will also be shown in blue in the Protection Set list. All others will be in black.

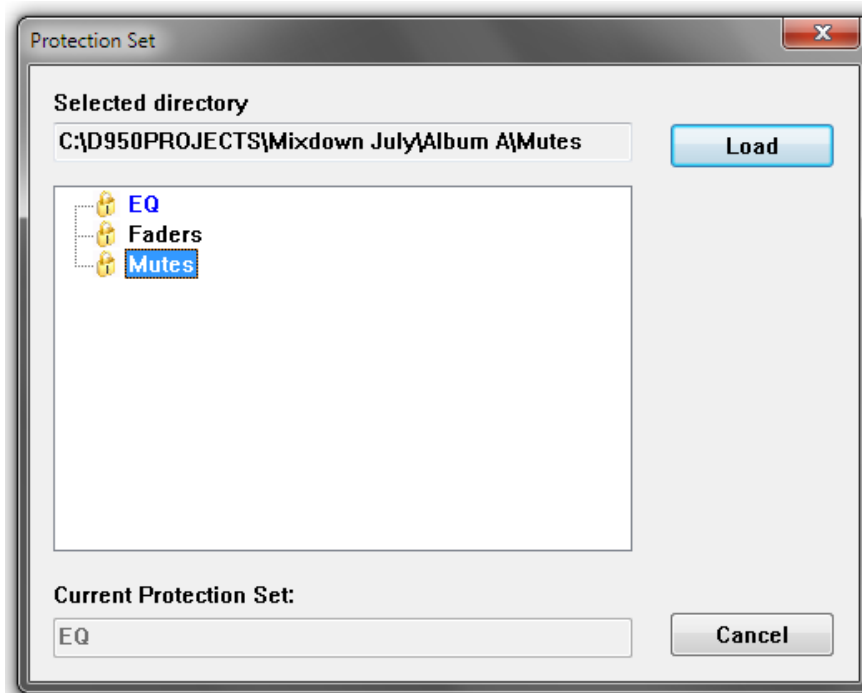

3. Double-click the desired Protection Set or click it and 'Load'. The selected set will become the current set and the selection box will close.

Note Protection Sets cannot be loaded from other Titles. Protection Sets made within a Title are only available to that Title. Protection Sets made within a Title are available to all Mix Passes within that Title.

5.14.2 Applying Mix Protection

One or more Protection Sets may be applied simultaneously. This affords multiple layers of protection, which may be built up during the course of a mix. These layers of protection may be quickly applied and removed as needed. If a Title is being used as a production template, the saved Protection Sets may be used with any Mix Pass created using that template.

Important Note

When Mix Protection is enabled, Protection is applied to the Active Pass. All protected controls will be protected regardless of which Mix Pass is made active.

Selecting Protection Sets

How Protection Sets are selected is determined by selecting the desired radio button in the 'Use' section of the 'Automation Protection' window.

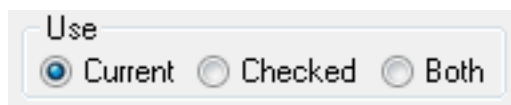

These radio buttons allow the selection of Protection Sets one of three ways:

- **Current:** The current Protection Set will be selected.
- **Checked:** The checked Protections Sets will be selected. A list of Protection Sets is displayed in the Protection Set section of the Automation Protection window. Each Protection Set has a box which may be 'checked' to include that set in the list of checked sets. The current Protection Set is not selected.

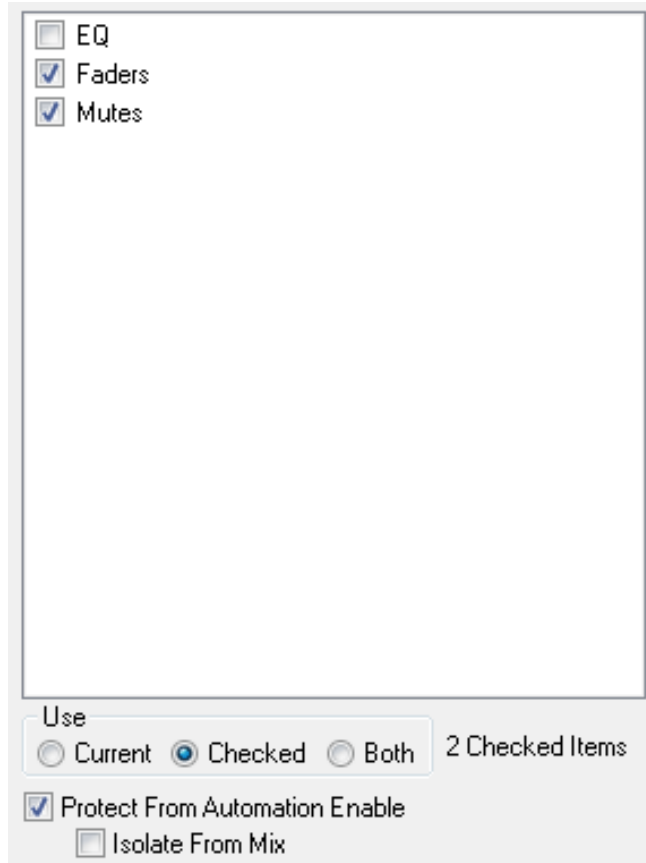

- Both: The current Protection Set and any checked sets will be selected.

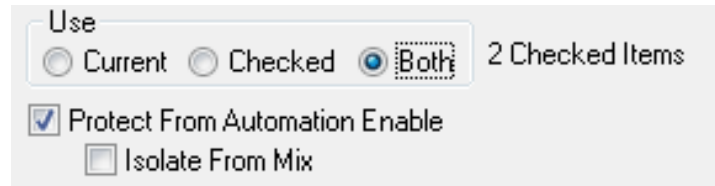

Applying Protection Sets

To apply one or more Protection Sets, use the following procedure:

1. Click the 'Mix Protection Enabled' button to open the 'Automation Protection' window if it is not already open.
2. Click 'Current', 'Checked' or 'Both' in the 'Use' section as appropriate. If 'Checked' or 'Both' are selected, check the needed Protection Set(s).
3. Check the 'Protect From Automation Enable' box in the 'Protection Set' section to apply Protection to the selected set(s) (Mutes on channels 1-12 per the example).
4. If desired, check the Global Patch 'Protect From Automation Enable' box to apply Protection to the General Patch.
5. Click the 'Use' button at the bottom of the window. The window will close and Protection will be applied to the controls included within the Protection Set (Mutes on channels 1-12 in the example). The 'Mix Protection Enabled' LED will illuminate.

Note If neither Protection Set nor Global Patch 'Protect From Automation Enable' box is checked, Protection will not be applied.

5.14.3 Removing Protection

Just as Protection may be applied in layers, it may be removed in layers or entirely.

To remove one or more Protection Sets, use the following procedure:

1. Click the 'Mix Protection Enabled' button to open the 'Automation Protection' window if it is not already open.
2. Click 'Current', 'Checked' or 'Both' in the 'Use' section as appropriate. If 'Checked' or 'Both' are selected, uncheck the unneeded Protection Set(s).
3. If desired, uncheck the Global Patch 'Protect From Automation Enable' box to remove Protection from the General Patch.
4. Click the 'Use' button at the bottom of the window. The window will close. Any selected Protection Sets will remain active and those deselected will be removed. Protection will be removed from the controls included within the deselected Protection Set (Mutes on channels 1-12 in the example). The 'Mix Protection Enabled' LED remains lit if any controls remain Protected.

Shortcuts

To quickly remove Protection from all controls, uncheck the 'Protect From Automation Enable' box in the Protection Sets section of the 'Automation Protection' window and click the 'Use' button.

To quickly remove Protection from the General Patch, uncheck the 'Protect From Automation Enable' box in the Global Patch section of the 'Automation Protection' window and click the 'Use' button.

5.14.4 Isolate via Protection

Controls and the General Patch can be forced into ISOLATE using the Mix Protection selection methods. This is different from selecting the ISOLATE Control Mode in that Isolation persists only as long as the Protection Isolation is applied. This provides a convenient method of temporarily Isolating controls in any Mix Pass without creating new passes.

To apply Isolation via Protection, the same methods are used as when creating and applying Protection Sets. The only difference is 'Isolate From Mix' is checked for either Protection Sets, Global Patch, or both before Protection is applied.

Use

Current Checked Both

Protect From Automation Enable
 Isolate From Mix

Global Patch

Protect From Automation Enable
 Isolate From Mix

Use Save Cancel

5.15 Miscellaneous Controls/Modes

A variety of controls and modes that are not explained elsewhere are described below.

5.15.1 Mix On

Engaging the **Mix On** button (or the **Mix On** desk key) activates the AutoTouch-Plus system. A **Mix Tree** must be open before the system may be turned On. When the system is On, the **Mix On** button and desk key illuminate.

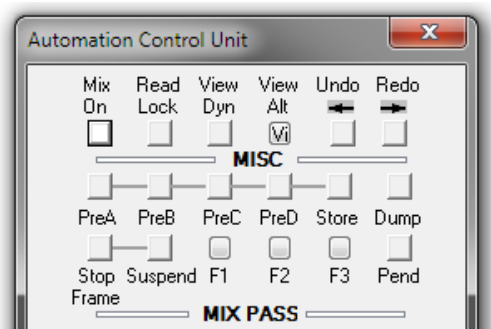

5.15.2 View Dynamic

Clicking **VIEW** will cause the lights for all dynamic controls currently on the Desk to illuminate. Static controls will not light. This provides a very quick and easy means of identifying which controls have Dynamic moves recorded and which are Static controls. See Graphic above.

5.15.3 Scene Capture/Recall

A Scene is a global ‘snapshot’ of the automation status of each control within the system. There are two buffers in which Scenes may be stored. Scenes will be stored and can be recalled during subsequent sessions.

Note The term ‘snapshot’ is not the same as a Snapshot in the GC. Snapshot in this regard refers to a picture of the automation status console-wide.

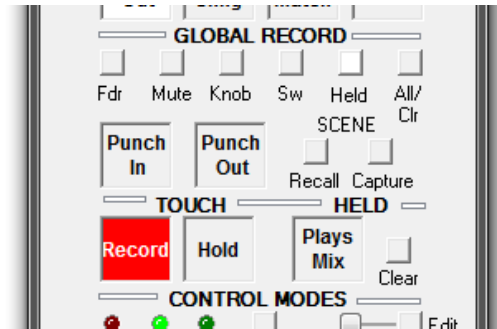

Scene Capture Clicking the **Store** button followed by a click on **SCENE – Capture** will ‘capture’ a Scene in the first buffer. Holding the **ISO (AUTO MODE)** and **STORE** keys and pressing **ISO (AUTO MODE)** and **SCENE – Capture** will ‘capture’ a Scene in the second buffer.

The **SCENE – Recall** button will illuminate when a Scene has been captured in the first buffer. There is no indication of the status of the second Scene buffer.

The following controls will be stored within a Scene:

- Controls in **RECORD**
- Controls that are Held
- Controls that are being touched when the Scene is captured

A list of controls and their values will be stored when a Scene is captured.

Note If no controls are in the states listed above, the existing Scene buffer will remain intact.

Scene Recall Clicking the **SCENE – Recall** button will ‘recall’ the Scene stored in the first buffer. Holding **ISO (AUTO MODE)** modifier key and clicking the **SCENE – Recall** button will recall the Scene stored in the second buffer.

When a Scene is recalled, the controls on the list come back Held and **WRITE Enabled**. The values for the controls in the buffer will be reinstated as well. If **TOUCH – Record** is active, the controls in the list will punch-in to **RECORD** upon Scene Recall

Clearing a Scene Buffer Clicking the **GLOBAL RECORD – All / Clr** button followed by a click on **CLR / ALL** and **RCL** will ‘clear’ a Scene in the first buffer. Clicking **GLOBAL RECORD – All / Clr**, holding **ISO (AUTO MODE)** followed by a click on **SCENE – Recall** will clear the second Scene buffer.

Note The data in the Scene Buffer is *not* saved as part of a Mix Pass, Mix Tree, or Title. Therefore, it will *not* persist from session to session.

5.16 Special Operating Modes

AutoTouchPlus offers a series of special operating modes and features to accommodate specific production requirements and working styles.

5.16.1 Stop Frame Automation

The Stop Frame automation feature makes it possible to write specific control values between timecode locations. The user can stop timecode playback at a specific location, set any number of controls to desired values, and move to the next location forward in time where values may again be adjusted. The initially set values will be recorded between the timecode locations.

Stop Frame automation may also be used with the internal timecode generator and LOCATE button when working with an EDL (Edit Decision List). This allows automation data to be recorded in a 'pseudo offline' fashion without the work media.

Stop Frame Automation may be enabled at any point. After control values are written at a specific location, the media can be moved forward to the next location, and the next set of values can be written. If locations are not known, Stop Frame may be 'suspended' as the media is searched.

Stop Frame Controls

There are two buttons in the ACU window associated with Stop Frame automation.

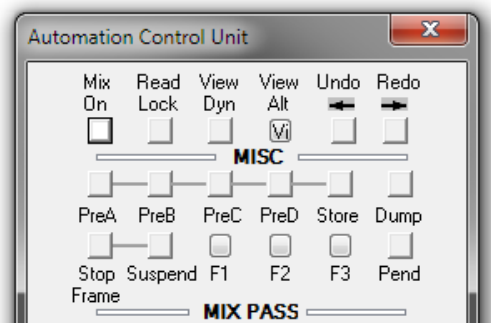

The Stop Frame buttons perform the following functions:

- **STOP FRAME:** When engaged, all enabled controls will switch to their active RECORD state. The values of these controls will be recorded at the current timecode location. If timecode is advanced, these values will be recorded to each consecutive location. At any time, the user may stop timecode playback and make further adjustments to the controls. The new values will be recorded at the current location and any consecutive ones if the media is moved forward. It is important to note that control values will not be recorded if the timecode is moved backward.
- **SUSPEND:** When engaged, Stop Frame recording is suspended. This allows timecode to be moved backward or forward so a the next timecode location may be found. No control values will be written while SUSPEND is engaged.

Using Stop Frame Automation

The procedures for using Stop Frame Automation are as follows:

1. Select **Write Enable** or **Trim Enable** and the desired preselector(s).
2. Engage **TOUCH – Record** so that touched, enabled controls change to RECORD. Also engage **TOUCH – Hold** so controls won't snap back to previously written values when un-touched.
3. Move the media forward and stop media at a desired timecode location.
4. Enable Stop Frame by clicking the **Stop Frame** button, if it is not already on. The **Stop Frame** button will illuminate and record status will change to 'Ready.'
5. Adjust enabled controls to the desired values while sitting at that location. Any touched control will enter RECORD and its value can be set. The final value for each control will be recorded at that location and every consecutive timecode location played into the system. This is typically to the next Stop Frame location, but transitions will be applied according to the chosen Write To: function.
6. Clicking the **Stop Frame - Suspend** button will release Stop Frame from timecode. This allows the media to searched forward *and backward* in order to find the next timecode location.
7. Once values have been recorded at all desired locations, turn Stop Frame off, by disengaging the **Stop Frame** button. A new Mix Pass will be created and added to the Mix Tree and Mix Pass Stack.

5.16.2 Read Lock

READ LOCK forces all controls into Read and locks out all changes. While in this mode, playing back the Read Mix data from the Active Pass is the only operation possible. This assures the Active Pass will be played back exactly as saved, which can be quite useful when printing a final mix or layback.

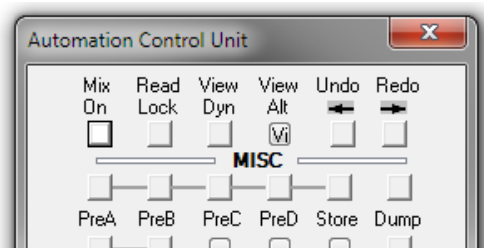
**Conditions**

With **READ LOCK** engaged, the following conditions exist:

- All controls are placed into the READ Control Mode and then locked in READ. Only the stored values of the Active Pass will be heard. Changes to control values are not possible. All controls are Protected.
- Changes may not be made to Static controls, the Channel Patch, or the General Patch
- Control Mode changes are locked out
- Controls may not be placed in a Held state (**TOUCH – Hold** defeated)
- All Record functions are defeated (**TOUCH – Record**, GLOBAL RECORD PUNCH-IN/PUNCH-OUT)
- All Audition functions are defeated
- SCENE RCL is defeated

5.17 Offline Mix Editing

There are two methods of offline editing of Mix Passes:

- **Event List Editing:** The location of automation records may be moved or 'slipped in time.' Automation records may also be deleted. Control values may not be edited.
- **OFLA Editing:** Allows the value of automation records to be changed within a timecode window. Controls can also be reset to their default values or have their values frozen or spread across the timecode window. Controls can be made Static and Mix Passes may be merged.

Together, these methods provide powerful and easy-to-use means of fine tuning Mix Pass data or working with Edit Decision Lists. Each Method of editing is described below.

5.17.1 Event List Editing

Automation data may be edited using the Event List Editor within AutoTouchPlus. Being fully integrated within AutoTouchPlus, the Event List Editor provides quick and easy means of moving the location of automation records (Events). Automation events can also be deleted.

Accessing the Event List Editor

The Event List Editor is available by selecting 'Event List Editor' from the GC Automation menu.

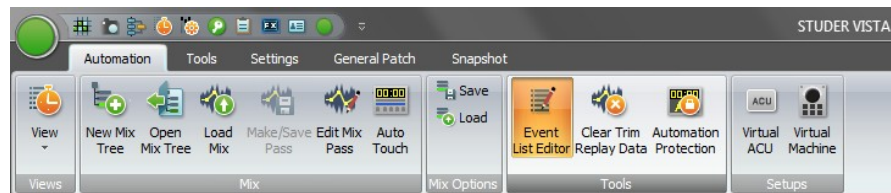

This action will open the Event List Editor window.

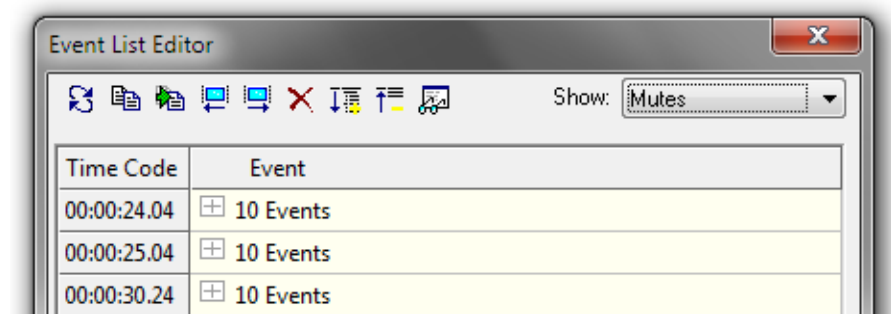

Events and Event Lists

As a mix progresses, Events (automation records) are recorded at timecode locations within a Mix Pass. These Events are organized by timecode and displayed in the Event List Editor. If more than one Event is recorded at the same timecode location, an Event List is created at that location. The Event List will contain all Events recorded at that location.

| Time Code | Event |
|-------------|-------------|
| 00:00:24.04 | ⊕ 10 Events |
| 00:00:25.04 | ⊕ 10 Events |
| 00:00:44.08 | ⊕ 10 Events |

Only the timecode location of an Event may be edited. Events may copied to new locations or be deleted from the new Mix Pass.

Important Note Control values may not be changed using the Event List Editor.

Displayed Events Since a vast number of Events may be generated during a mix, Event Lists become both very numerous and very large. In a large or complex project, the number of events can grow to be overwhelming. To solve this problem, the Events to be displayed may be selected in one of two ways:

- Show Menu Selections: The Event Editor will display only the items selected in this menu
- Event List Filter: The Event Editor will display only the items selected by the Event List Filter

Show Menu Selecting an item from the ‘Show:’ pull-down menu will select the Events for that item’s controls to be displayed in the Event List Editor.

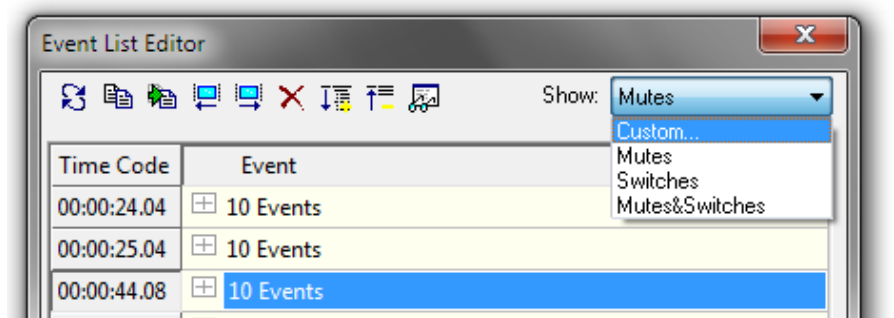

The following sets of Events are available in the ‘Show:’ menu:

- Custom...: Allows a customized set of Events to be displayed. Selecting this item will open the Event List Filter where an exact set of Events may be chosen for display (see below). If a set of custom set of Events has already been selected, choosing ‘Custom...’ will display the Events within that set.
- Mutes: Only Mute Events will be displayed in the Event List Editor
- Switches: Only Switch Events will be displayed in the Event List Editor
- Mutes & Switches: Only Mute and Switch Events will be displayed in the Event List Editor

Event List Filter Using the Event List Filter, Events for specific controls can be selected for display in the Event column of the Event List Editor window.

To access the Event List Filter, click the  icon.

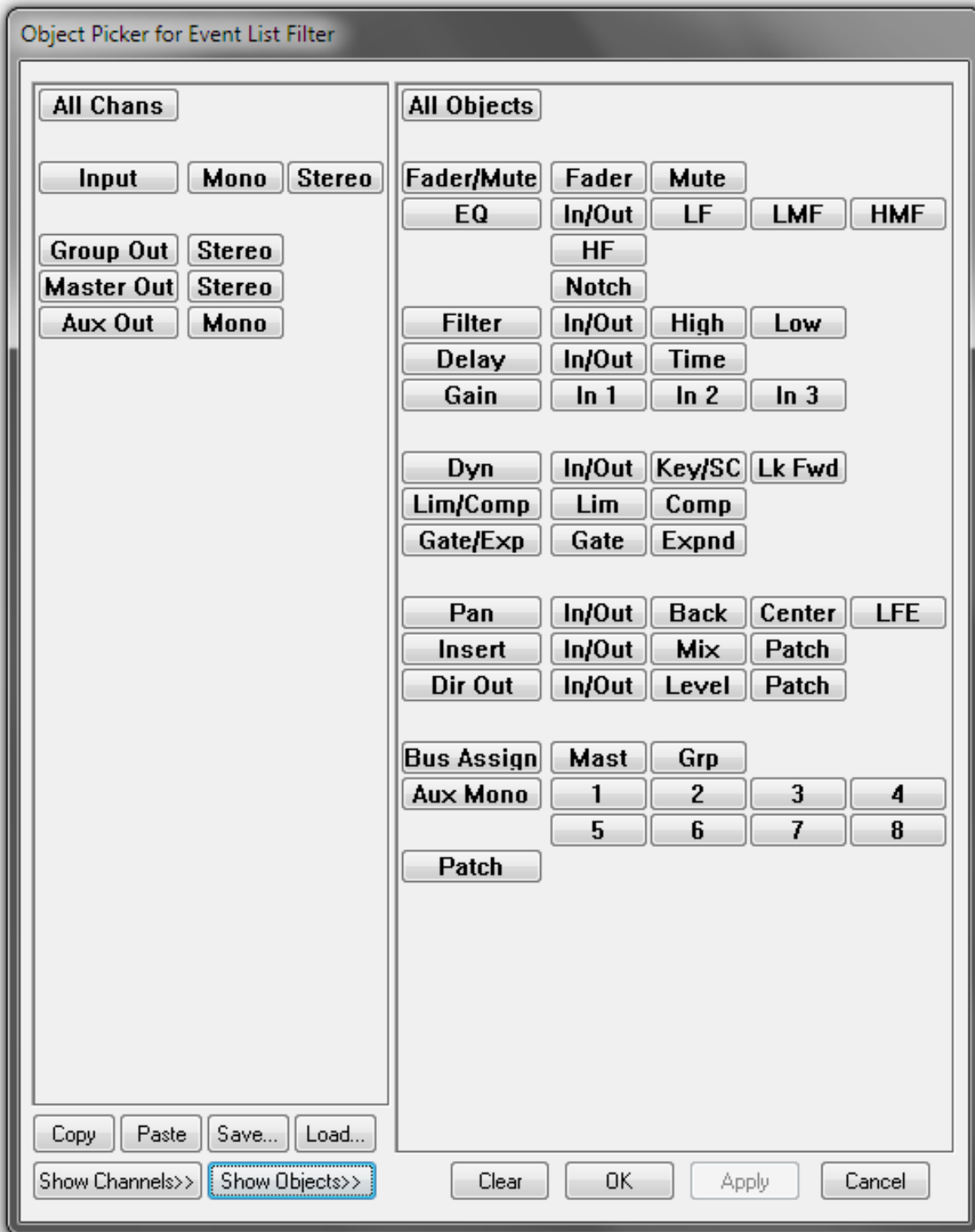

The Event List Filter provides the means to select desired controls within desired channels for display within the Event column. This set of Events is not limited to Mutes and Switches. Any combination of channels and controls is possible. Using the Object Picker for the Event List Filter, it is possible to select an exact set of controls for which Events will be displayed. For example, to edit Mute locations, only the Events for Mutes on selected channels may be chosen for display. This will remove all other Events from view and provide an efficient means of performing Mute Event edits.

Notes Automated Graphical Controller items are not selectable using the Object Picker for the Event List Filter.
If objects are selected for display that do not have recorded Events, the Event List will be empty.

Event List Display

Selected Events may be displayed in a number of ways.

- Individual Events: Individual Events will be displayed next to their time-code location. The Event label contains the channel type, channel number, control, and control value. Timecode locations are always shown for each individual Events.
- Consolidated Event Lists: Only timecode locations with recorded Events are displayed. If only a single Event is recorded, it will be displayed. If multiple Events have been recorded at the same timecode location, an Event List header will be shown, but the contents will not be displayed. The header label will indicate the number of Events in the list and contains a '+' button. Clicking the '+' button will expand the list, its contents will be displayed, and the '+' button changes to a '-' button. Clicking the '-' button will close the list.
- Expanded Event Lists: All Events are shown individually. If an Event is part of an Event List, the header will be the first item for that particular timecode location.

| Time Code | Event |
|-------------|-----------------------------|
| 00:00:24.04 | ⊕ 10 Events |
| 00:00:25.04 | ⊕ 10 Events |
| 00:00:44.08 | ⊕ 10 Events |
| 00:00:48.06 | ⊖ 10 Events |
| 00:00:48.06 | Inp Mono # 1:Fader Mute OFF |
| 00:00:48.06 | Inp Mono # 2:Fader Mute OFF |

Important Note The use of the term 'Mute' is used literally in the Event List Editor. If the Mute is listed as 'ON' in the Event List, the post fader channel output will be cut. Muting will be activated. The associated **MUTE** key on the desk will not be illuminated

Notes The Event List Editor only shows a subset of all the events stored within a Mix Pass. Making an edit can change what is shown and depending on the edit performed, some events may drop off the list.
Timecode locations without recorded Events will not be displayed in the Event List Editor.

Selecting Events to be Edited

From the Events chosen for display, single Events, an entire Event List, or a selected group of Events and/or Event Lists may be chosen for editing.

Use the following procedures to select Events and/or Event Lists may be chosen for editing:

- Individual Events: Individual Events may be selected by clicking the Event label or the associated timecode. To select individual Events from an Event List, the list must first be expanded.

- Event Lists: Individual Event Lists may be selected by clicking the Event List header or the associated timecode.
- Selected Events and/or Event Lists: A group of selected Events and/or Event Lists may be chosen using any of the following methods:
 - Click and Drag: Click and hold on an Event or Event List and drag the cursor over the desired items. This allows adjacent items to be selected.
 - Control-clicking (holding the Ctrl key plus single-clicking): Allows selection of individual Events and/or Event Lists anywhere within the Event List Editor. Items may be selected regardless of location, so non-adjacent items may be chosen.
 - Shift-clicking (holding the Shift key and single-clicking): Allows selection of a range of Events and/or Event Lists. Clicking a pair of items while holding down the Shift key will select those items and the ones in-between.

Event List Editor Operations

The following operations may be performed using the Event List Editor:



Redisplay Event List Near Current Timecode: Opens the Event List closest to the current or selected timecode location.



Copy Event(s) to New Timecode: The selected Events and/or Event Lists are copied and pasted to a new timecode location. When selected, a timecode entry box will open.



Move Event(s) to New Timecode: The selected Events and/or Event Lists are moved to a new timecode location. When selected, a timecode entry box will open.



Move Event(s) One Frame Earlier: The selected Events and/or Event Lists are moved one frame earlier. The selected items are 'nudged backward.'



Move Event(s) One Frame Later: The selected Events and/or Event Lists are moved one frame later. The selected items are 'nudged forward.'



Delete Selected Events: The selected Events and/or Event Lists are deleted from the resultant Mix Pass. Caution: No warning prompt is given. See Note below.



Expand and Show Each Event at a Timecode: All Events Lists are opened and each Event is displayed with its timecode location.



Consolidate Multiple Events at Each Timecode: Only Events Lists are shown at each timecode location. Individual Events will be shown only if they are the only Event at that timecode location.



Filter Which Events to Display: Opens the Object Picker for the Event List Filter.

Each time an Event List edit operation is performed, a new Mix Pass is created.

Note Deleting an Event or Event List is a destructive operation. However, the original Active Pass on which the edit is to be performed is retained and a new Mix Pass is created without the deleted item. In this regard, deleting an item is a non-destructive operation.

- Perform an Event List Edit** To perform an Event List edit, use the following procedure:
1. Make the Mix Pass to be edited the Active Pass if it is not already.
 2. Select 'Event List Editor' from the GC Automation menu. The Event List Editor window will open.
 3. Click the 'Edit List Filter' button to open the Object Picker for the Event List Filter. Using this picker will allow Events for the desired controls on selected channels to be chosen for editing. Once selected, click either the 'Apply' button (if more edits will be performed) or the 'OK' button (if no more objects need to be selected). Events for the controls in the picker will be selected for editing and will appear in the Event column of the Event List Editor window.
 4. Click the desired edit operation. If moving or copying Events and/or Event Lists, enter the new timecode location and click 'OK'. The selected edit will be performed.
 5. A new Mix Pass is written that contains the edited values.

5.17.2 OFLA Editing

AutoTouchPlus data may be edited using the OFLA offline mix editor. OFLA is stand alone mix editor that may be used with or without AutoTouchPlus. Being fully integrated with AutoTouchPlus, OFLA provides quick and easy comprehensive Mix Pass editing when used in a session environment. When used in an offline capacity OFLA is equally efficient.

OFLA allows the values of automation records to be edited within a timecode window. Objects can also be made Static using OFLA.

Accessing OFLA OFLA is available by selecting 'Edit Mix Pass' from the GC Automation menu.

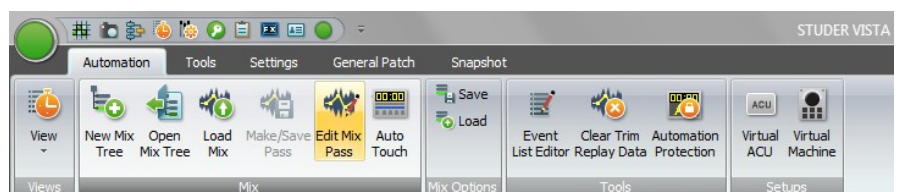

This action will open the Event List Editor window:



OFLA Edit Types There are eight different Edit Types available. It should be noted that all Edit Types are not available for all control types (for example, the value of a mute or switch cannot be trimmed).

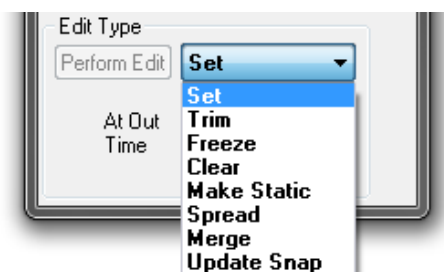

The following edit operations may be applied to selected controls using OFLA:

- **Set:** Sets a fixed control value within the timecode window.
- **Trim:** Offsets the previously written control values by a fixed amount within the timecode window. Switches may not be Trimmed.
- **Freeze:** The control value at the OFLA In time will be retained for the duration of the timecode window.

- Clear: Controls will be reset to their default values within the timecode window.
 - Make Static: Controls will be made Static. All automation records other than the Static value will be erased for the entire Mix Pass.
 - Spread: Control values at a specific point in a source mix (Active or Mix Tree) may be applied throughout the timecode window.
 - Merge: Control values of a timecode window within a source mix (Active or Mix Tree) may be applied throughout the timecode window.
 - Update Snap: Updates the Mix Snapshot. This applies the current control values from the beginning of the Mix Pass to the first recorded record.
- Each time an OFLA edit is performed, a new Mix Pass created.

Edit a Mix Pass with OFLA

To edit a Mix Pass with OFLA, use the following procedure:

1. Make the Mix Pass to be edited the Active Pass if it is not already.
2. Select 'Edit Mix Pass' from the GC Automation menu. The basic Edit Mix window will open.
3. Click the 'Select' button to open the Object Picker for Edit Object Selector. Using this picker will allow the desired controls on selected channels to be chosen for editing. Once selected, click either the 'Apply' button (if more edits will be performed) or the 'OK' button (if no more objects need to be selected). The controls in the picker will be selected for editing and will appear in the Selected Objects section of the Edit Mix window.
4. Select the Edit Type from the 'Edit Type' pull-down menu.
5. Enter the new control value if necessary (depending on Edit Type).
6. Enter the Spread Source Mix or Merge Mix if Spread or Merge edit types are used. The Mix Passes in the current Mix Tree are available.
7. Enter the timecode locations for edit In and Out points if necessary (depending on Edit Type).
8. Click on the appropriate radio button to select the 'At Out Time' function. These functions mostly mirror the 'Write To' functions found in AutoTouchPlus, but have some difference. See below.
9. Click 'Perform Edit' to perform the edit. A new Mix Pass is written that contains the edited values.

Note Automated Graphical Controller items are not selectable using the Object Picker for Edit Object Selector.

At Out Time Functions

The select 'At Out Time' function will determine how the edit data transitions back to Read Mix data.

At Out Time selections function as follows:

- Restore Values: This is the equivalent to **Write To: Punch Out**. Read Mix control values will be restored at the OFLA Out Time. Glide functions are not available.
- Write to End: This is the equivalent to 'Write To: End' except the edit control values will be written to the end of the Mix Pass. To use a fixed end time select Restore Values as the At Out Time function. 'Write To: End Of Time' is not available.
- Write to Next Change: This is the equivalent to 'Write To: Next Change'. Read Mix control values will be restored when the next record is encountered. Glide functions are not available.

5.17.2.1 Object Picker

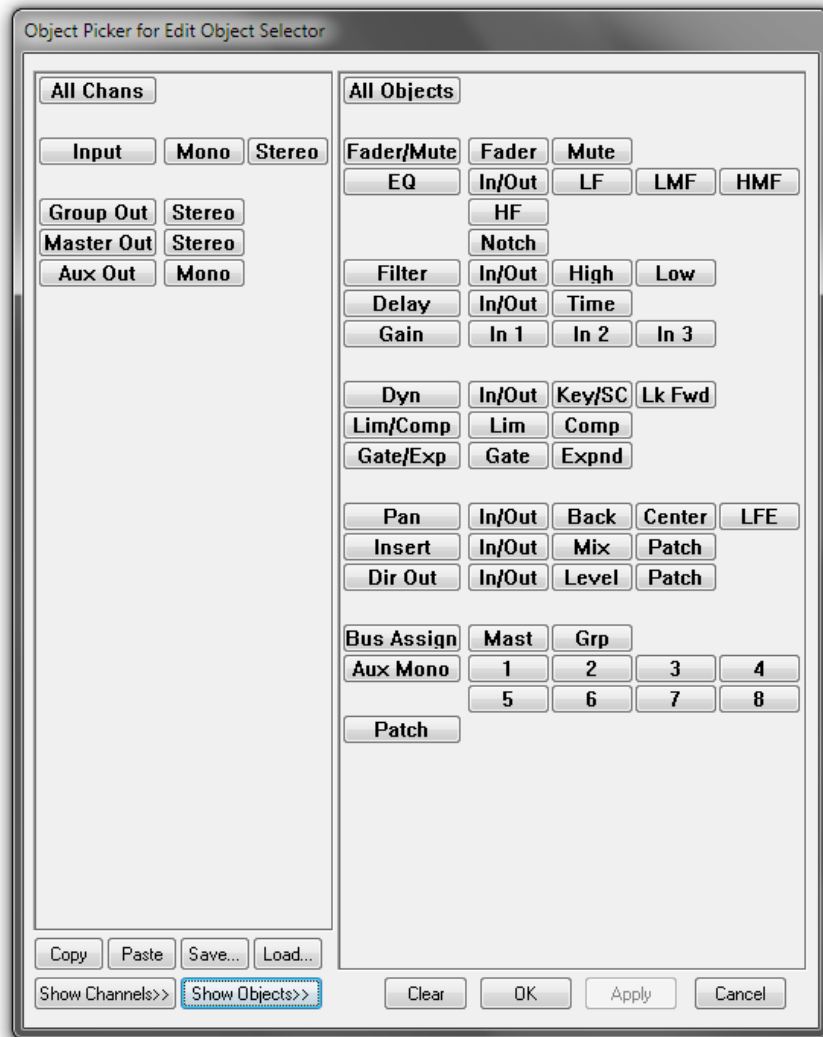

The Object Picker is used to select the elements within a mix you wish to edit. These elements are organized into channels and objects within channels. Selection of elements can be as specific as an individual parameter value, within a particular object, within a single channel, and as broad as all parameters, within all objects, within all channels.

Note It is important to realize that the channels and objects displayed in the picker are the same as contained within the VMC used to create the title and mix. If a different VMC is loaded, the channels and objects will change accordingly. In other words, the elements that appear in the Object Picker are determined by the console configuration that was in use when the data was created.

There are five main sections in the Object Picker:

- Channel Selector window;
- Object Selector window;
- Channel/Object Tree display area;
- Function controls;
- Open Mix Selector Tabs.

5.17.2.2 Channel Selector Window



This window contains buttons that correspond with the channels that are present within the active mix. Using these buttons, channels can be selected for editing as follows:

| | |
|-------------------|--|
| <i>All Chans</i> | selects all channels for editing; |
| <i>Input</i> | selects all Input channels for editing; |
| <i>MT Input</i> | selects all Multitrack Input channels for editing; |
| <i>MT Monitor</i> | selects all Multitrack Monitor channels for editing; |
| <i>Group Out</i> | selects all Group Output channels for editing; |
| <i>Master Out</i> | selects all Master Output channels for editing; |
| <i>Aux Out</i> | selects all Auxiliary Output channels for editing. |

Activating the left-hand button at the beginning of each row will select all channels of that type. If both mono and stereo versions of a particular channel type are included in the VMC, just the mono or stereo channels may be selected by clicking on the appropriate button. Channel types and/or versions may be de-selected after a large selection (such as All Chans) has been made.

In addition to channel selection, buttons are included that allow editing of group assignments and Control Group Masters. Channels that contribute to each group may be also selected for editing *as a group*, via these controls. These buttons function as follows:

| | |
|---------------|--|
| <i>Group</i> | selects all items associated with the group (group members, Control Group Masters, and group assignments) for inclusion in the edit; |
| <i>Master</i> | selects Control Group Masters for inclusion in the edit; |
| <i>Member</i> | selects group members and group assignments for inclusion in the edit. |

A set of 'Group', 'Master', and 'Member' buttons is provided for each group. The top row of buttons act as global selectors for the group controls below.

The assignments of channels as group members are stored as part of the mix data and may be unique to each mix. Therefore, only groups that have channels assigned as members will have 'Member' buttons available with the group. In other words, whether or not the 'Member' buttons appear in the Channel Selector Window is determined by the loaded mix/snapshot.

Notes User Labels can be displayed on ‘Group’ buttons by selecting ‘User Labels on Group Buttons’ from the Options menu.
 The buttons in the Channel Selector Window select channels and groups on a global basis. If individual (or subsets of) channels/groups are to be selected for editing, the ‘Show Channels>>’ facility must be used.

5.17.2.3 Object Selector Window



This window contains buttons that correspond with the elements (or objects) that are contained within the channels.

Note It is important to realize that the Object Selector Window will display *all* elements that are included in the VMC. While an object might appear in the window, it might not be configured within the selected channel(s). Objects not included anywhere in the VMC will not appear in the Object Selector Window.

Using these buttons, objects can be selected for editing as follows:

| | |
|--------------------|---|
| <i>All Objects</i> | selects all objects for editing; |
| <i>Fader/Mute</i> | selects all fader and mute parameters for editing; |
| <i>EQ</i> | selects all EQ parameters for editing; |
| <i>Filter</i> | selects all filter parameters for editing; |
| <i>Delay</i> | selects all delay parameters for editing; |
| <i>Gain</i> | selects all input gain parameters for editing; |
| <i>Dyn</i> | selects all limiter/compressor <i>and</i> gate/expander parameters for editing; |
| <i>Lim/Comp</i> | selects all limiter/compressor parameters for editing; |
| <i>Gate/Exp</i> | selects all gate/expander parameters for editing; |
| <i>Pan</i> | selects all pan parameters for editing; |
| <i>Insert</i> | selects all insert parameters for editing; |
| <i>Dir Out</i> | selects all direct output parameters for editing; |
| <i>Bus Assign</i> | selects all bus assignments for editing; |
| <i>Aux Mono</i> | selects all mono auxiliary parameters for editing; |
| <i>Aux Stereo</i> | selects all stereo auxiliary parameters for editing; |
| <i>Patch</i> | selects all patch assignments for editing |

Selection of an object will select all objects of that type for editing. For example, if all four EQ types have been configured in the VMC (mono, stereo, mono with notch, and stereo with notch), all four EQ types will be selected when the 'EQ' object button is clicked.

Each object contains an appropriate set of parameters for that object's functions. Several parameters may be selected by clicking a single button. For example, if Filter/High is clicked, then HP on/off, HP slope, and HP frequency will all be selected.

Activating the left-hand button at the beginning of each row will select all parameters for that object. Objects and/or their parameters may be deselected after a large selection (such as All Objects) has been made.

Note The buttons in the Object Selector Window select objects and parameters on a global basis. If individual or subsets of parameters are to be selected for editing, the 'Show Objects>>' facility must be used.

5.17.2.4 Channel/Object Tree Display Area

All channels and objects may be displayed in a tree format. This provides the means to select specific channels and/or objects on an individual, subset, or global basis. This display area is located to the right of the Object Selector Window and will be blank if both trees are hidden.

To view the Channel Tree, click the 'Show Channels>>' button located under the Channel Selector Window. All the channels included in the VMC, along with their User Labels, will be contained in the tree (left part of the picture below).

To view the Object Tree, click the 'Show Objects>>' button. All objects included in the configuration will be included within the tree. Only one tree can be displayed at any one time (right part of the picture below).

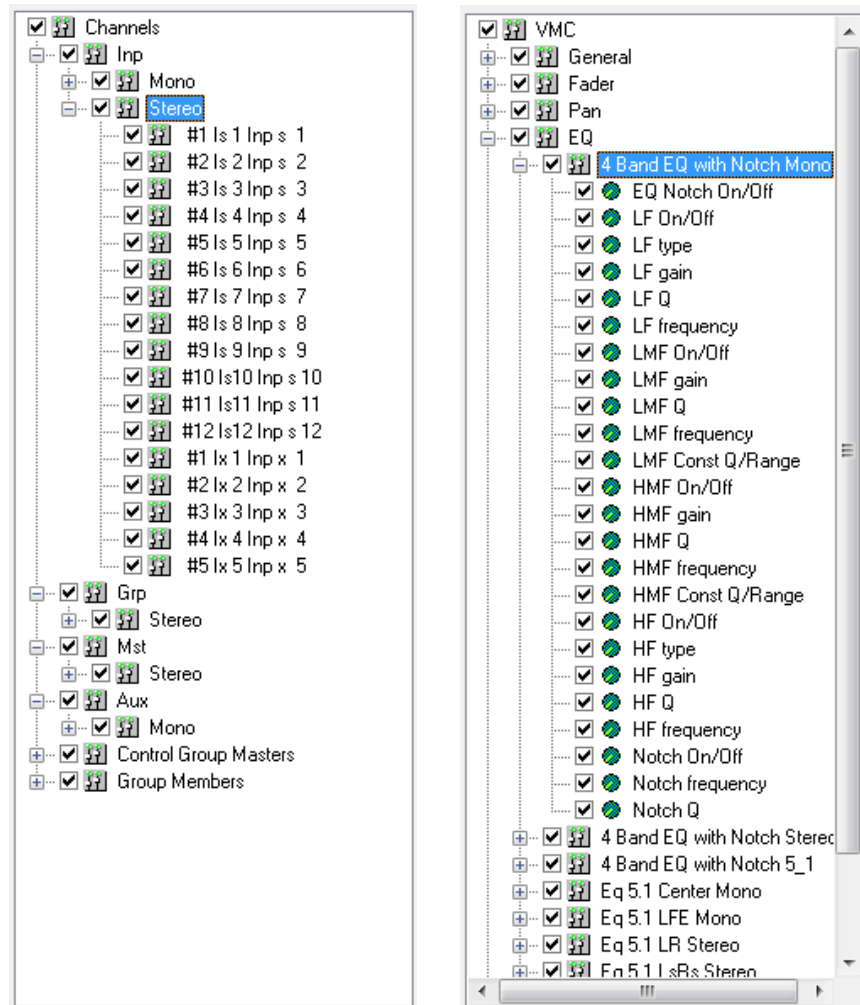

Once a tree has been chosen, all of the individual elements it contains may be viewed by opening the displayed folders and folders within folders (click the '+' icons to open folders and the '-' icons to close them). Like the channel/object selectors, only elements contained within the VMC are displayed.

Items can be selected for editing by checking any combination of folders and/or individual elements within the tree. Using this method, an exact set of elements, either simple or complex, can be chosen. Because of this high resolution, a much more precise set of elements may be selected than what is possible using the channel/object selector windows.

An item can be checked or unchecked by clicking on the box next to its name. Several items may be selected by highlighting the item labels using the familiar Shift-click and Ctrl-click methods. Once the labels have been highlighted, Right-clicking will open a pop-up menu that allows the group to be checked or unchecked.

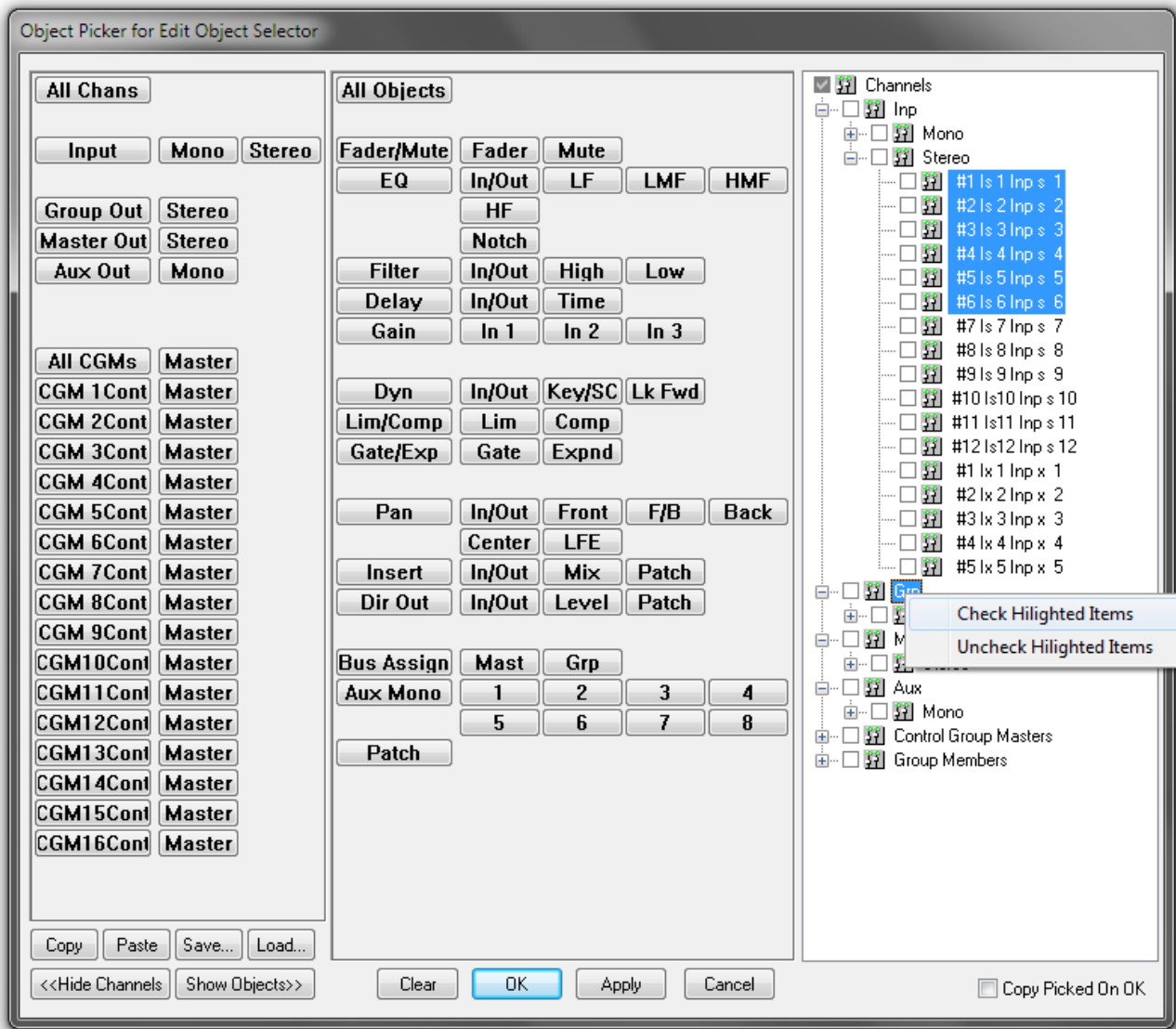

Notes When all items within a channel/object section have been chosen, the associated selector button(s) will illuminate with a dark blue light and the associated tree elements will be indicated with a black check. If only part of a section is chosen, the associated selector buttons will illuminate in light blue and the tree elements will be checked in gray. Notice the relationship between the channel/object selector windows and the tree displays. When an element is chosen using a selector window, the corresponding element is checked in the tree. Likewise, if an item is checked in the tree, the corresponding selector button is illuminated.

5.17.2.5 Function Controls



A set of function controls is provided below the Channel/Object Selector windows. These function buttons are as follows:

- Copy* copies the Selected Objects Set to the PC clipboard;
- Paste* pastes the contents of the PC clipboard (copied Selected Objects Set) to the Object Picker;
- Save...* saves the Selected Objects Set as a file;
- Load* allows saved object files to be reloaded;
- Clear* clears the selection of all objects;
- Apply* selects the objects chosen in the Object Picker for editing;
- OK* selects the objects chosen in the Object Picker for editing and closes the Object Picker window.
- Copy Picked on OK* if checked, the Selected Objects Set is copied to the clipboard when the 'Apply' button is clicked;
- Cancel* cancels changes made to the Selected Objects Set since the last set was applied, saved, loaded, copied, or pasted.

Once an object or set of objects has been selected in the Object Picker, they are then selected for editing by clicking the 'Apply' button. The selected objects from the selected channels will be displayed in the 'Selected Objects' window. Those are the only objects that will be affected when edits are performed.

- Note** If an object has been chosen but a channel has not, the object will not be selected for editing when the 'Apply' button is clicked.

- Open Mix Selector Tabs** A set of tabs, each of them representing a mix, are located at the bottom of the Object Picker window (bottom left in the picture above). Every mix that is currently open in the OFLA has its own tab. When the mix selector menus are set to 'Selected Mix', these tabs are used to choose a mix by simply clicking on the appropriate tab.

5.17.3 Mix Controls

All edits are based upon an existing mix, known as the Active Mix. Depending on the type of edit selected, data may be needed from another mix or snapshot. The controls for the necessary mixes appear in the combo boxes to the right of the Object Picker or Mix Viewer window.

5.17.3.1 Active Mix

The Active Mix provides the primary data set that is used during editing. Every edit is based upon the selected Active Mix, the channels/objects selected within the mix, the portion of the mix to be altered, and the type of edit applied. In other words, the data (parameter values) from the selected Active Mix objects is altered according to the chosen Edit Type and Edit Region when the edit is performed. Previously existing and altered data are combined and saved as a new mix.

Most Edit Types (Set, Trim, Freeze, and Clear) need data from only the Active Mix for an edit to be performed. Spread, Merge, and Update Snap edits all require data from other mixes. When an additional data source is needed to perform an edit, an additional mix combo box (containing the appropriate controls) will appear when the corresponding Edit Type is chosen.

Each mix needed for an edit has a combo box that contains the necessary controls for that mix and edit type.

The Active Mix combo box has a primary control set:

- *Timecode Entry Fields*, used to select the Edit Region.

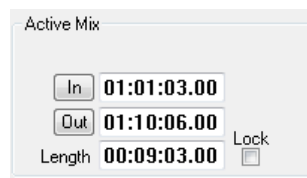

Timecode Entry Fields

For most edit types to be performed, an Edit Region must be established within the Active Mix using timecode addresses (Update Snap does not use an Edit Region). The Edit Region can be as short as a single frame or as long as an entire mix.

Edit Regions are defined using Timecode Entry Fields. The Active Mix includes three Timecode Entry Fields:

| | |
|--------------------|---|
| <i>In Time</i> | Starting point for the edit; the timecode address from which data is altered; |
| <i>Out Time</i> | Ending point for the edit; the timecode address from which data is no longer altered; |
| <i>Length</i> | Duration of the edit; the total time of the Edit Region; |
| <i>Length Lock</i> | Freezes the value of the Length field. |

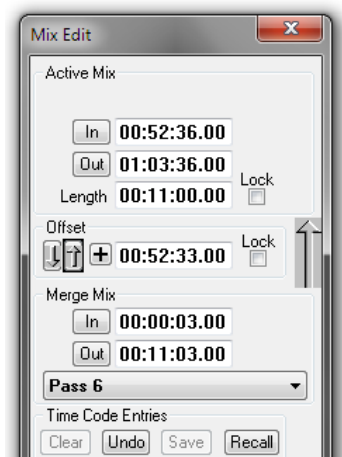

Timecode addresses may be entered into all three fields in the following ways:

- Capture the current timecode address using the 'In' or 'Out' buttons (if provided);
- Highlight all or a part of the entry field and type in the address;
- Highlight all or a part of the entry field and scroll the value up or down ('click-and-scroll method');
- Press the '+' or '-' key from the computer keyboard, and an additional Timecode Entry Field will appear. The value entered into this field will be added (+) or subtracted (-) from the existing timecode value.
- Right-Click any part of the entry field and a menu of timecode address selections from which to choose will appear;

Note Refer to [chapter 5.17.4](#) for additional details regarding timecode entries.

The In Time and Out Time entry fields are equipped with buttons that allow the capture of the current timecode address while the mix is stopped or running. Clicking on these buttons will enter the current address into the appropriate field.

Changes made to one of the entry fields may effect the address(es) of one or both of the other fields. For example, changes made in the In Time or Out Time fields will change the value of the Length time. Changes made in the Length field will change the value of the Out Time.

The Length field may be frozen by checking the Lock box to its right. When the Length field is locked, its value remains constant when changes are made in the other fields. Changes made to the In Time will change the Out Time and vice versa. It is important to note that the Length value may be edited even when it's locked.

Note Timecode Entry Fields do not appear in the Active Mix box when Update Snap is selected as the Edit Type.

5.17.3.2 Spread Source Mix

The Spread Source Mix allows external mix data from a single point in time (Data Point) to be applied to the Active Mix. The data from the selected point in an external mix (Spread Source Mix) is applied to the selected objects, on the selected channels, in the Active Mix during the Edit Region.

The Spread Source Mix combo box has two primary control sets:

- *Mix Selection Menu*: used to select the Spread Source Mix;
- *Timecode Entry Fields*: used to select the Data Point from the Spread Source Mix.

In addition, an Offset combo box is provided, so that the Active Mix and the Spread Source Mix *In Times* can be easily offset from each other.

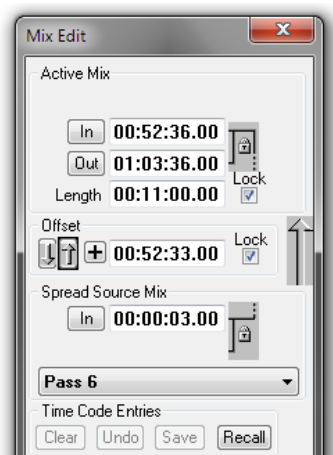

Mix Selection Menu This pop-up menu box provides a list of mixes available to become the Spread Source Mix. This list contains the same mixes available to the Active Mix and functions using the same selection techniques.

Note The Spread Source Mix is typically different from the Active Mix. However, it can also be the same mix as the Active Mix.

Timecode Entry Field For a Spread Edit to be performed, a Data Point (a single timecode address) must be selected from within the Spread Source Mix.

The Data Point is defined using a Timecode Entry Field. The Spread Source Mix has one Timecode Entry Field:

In Time Point from which the Spread Source Mix data originates, i.e. the timecode address of the Data Point.

The In Time from the Spread Source Mix is selected using the same techniques used for selecting the Active Mix timecode addresses.

Notes The In Time selects the Data Point (a specific frame) from the Spread Source Mix. This fixed data is applied throughout the entire Edit Region in the Active Mix.

Refer to [chapter 5.17.4](#) for additional details regarding timecode entries.

Offset Controls An Offset combo box is provided for easy control of offsets between the Active and Spread Source Mix In Times.

The Offset combo box for the Spread Source Mix contains the following controls:

Down Arrow Moves the Active Mix In Time to the Spread Source Mix In Time

Up Arrow Moves the Spread Source Mix In Time to the Active Mix In Time

+/- Box Toggles the Offset Value between positive (+) and negative (-); '+' is the

| | |
|---------------------|---|
| | default value |
| <i>Offset Value</i> | Difference between the Active Mix and Spread Source Mix In Times (00:00:00:00 is the default value) |
| <i>Offset Lock</i> | Freezes the Offset value |

The relationships between the Active Mix and Spread Source Mix In Times and the Offset Values are as follows:

- If the Active Mix and Spread Source Mix In Times are identical, the Offset Value will be 00:00:00:00
- If the Active Mix In Time is 10 seconds greater than the Spread Source Mix In Time, the Offset Value will be +00:00:10:00
- If the Active Mix In Time is 10 seconds less than the Spread Source Mix In Time, the Offset Value will be -00:00:10:00
- Changing either In Time will cause a corresponding change in the Offset Value unless it is locked
- Locking the Offset field will freeze its value. When locked, its value remains constant when changes are made in the other fields. Changing either In Time will then cause a corresponding change in the other In Time. It is important to note that the Offset Value may be edited even when it's locked

Note It is possible to lock both Length and Offset fields.

5.17.3.3 Merge Mix

The Merge Mix allows mix data from a region of an external mix to be applied to the Active Mix. The data from the selected region in an external mix (Merge Mix) is applied to the selected objects, on the selected channels, in the Active Mix during the Edit Region.

The Merge Mix combo box has two primary control sets:

- *Mix Selection Menu*: used to select the Merge Mix;
 - *Timecode Entry Fields*: used to select the source region of the Merge Mix.
- In addition, an Offset combo box is provided so the Active Mix and Merge Mix In Times can be easily offset from each other.

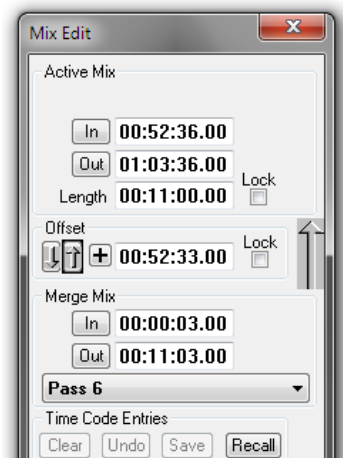

Mix Selection Menu This pop-up menu box provides a list of mixes available to become the Merge Mix. This list contains the same mixes that are available to the Active Mix and functions using the same selection techniques.

Note The Merge Mix may be the same mix as the Active Mix.

Timecode Entry Fields For a Merge edit to be performed, a Data Region from within the Merge Mix must be selected.

The Data Region is defined using Timecode Entry Fields. The Merge Mix has the following Timecode Entry Fields:

In Time This is the starting point of the Data Region from the Merge Mix;
Out Time This is the ending point of the Data Region from the Merge Mix.

The Merge Mix timecode entries are selected using the same techniques as used for selecting the Active Mix timecode addresses.

Notes The Data Region from the Merge Mix is applied to the Edit Region of the Active Mix. Therefore, the Data Region and Edit Regions must be the same length. Because of this, the Length field in the Active Mix box works in concert with the In Time or Out Time in both the Active and Merge Mix boxes. Changing the Length field will change the values in the Active Mix *and* Merge Mix boxes. Changing the Merge Mix In Time or Out Time will change the Active Mix In Time or Out Time values, as well as the Length value. Locking the Length field will affect the functions of the In Time or Out Time in both the Active Mix and Merge Mix sections.
Refer to [chapter 5.17.4](#) for additional details regarding timecode entries.

Offset Controls An Offset combo box is provided to facilitate easy control of offsets between the Active Mix and Merge Mix In Times.

The Merge Mix Offset controls function the same as the Spread Source Mix Offset controls.

5.17.3.4 Update Snap Source Mix

The Update Snap Source Mix allows external mix data from a single point In Time (Data Point) to be applied to the Active Mix. The data from the selected point in an external mix (Spread Source Mix) is applied to the selected objects, on the selected channels, in the entire Active Mix. It performs the same basic function as 'Update Mix Snapshot' from the Mix Options menu.

The Update Snap Source Mix combo box has two primary control sets:

- *Mix Selection Menu*: used to select the Update Snap Source Mix;
- *Timecode Entry Field*: used to select the Data Point from Update Snap Source Mix.

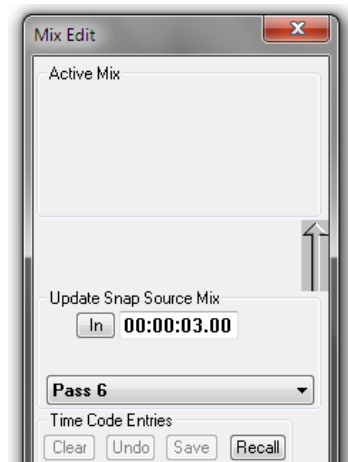

Mix Selection Menu This pop-up menu box provides a list of mixes available to become the Update Snap Source Mix. This list contains the same mixes that are available to the Active Mix and functions using the same selection techniques.

Note The Update Snap Source Mix may be the same mix as the Active Mix.

Timecode Entry Field For an Update Snap edit to be performed, a Data Point (a single timecode address) must be selected from within the Update Snap Source Mix.

The Data Point is defined using a Timecode Entry Field. Update Snap Source Mix has one Timecode Entry Field:

In Time This is the point from which the Update Snap Source Mix data originates; the timecode address of the Data Point.

The In Time for the Update Snap Source Mix is selected using the same techniques used for selecting the Active Mix Timecode addresses.

Notes The In Time selects the Data Point (a specific frame) from Update Snap Source Mix. This fixed data is applied throughout the entire length of the Active Mix. Therefore, the Active Mix does not contain any Timecode Entry Fields (In, Out, or Length) when Update Snap is selected as an Edit Type. Refer to [chapter 5.17.4](#) for additional details regarding timecode entries.

5.17.4 Timecode Controls

5.17.4.1 General Information

All timecode values are expressed as positive numbers and are limited by the number of timecode addresses available. Times cannot be less than 00:00:00:00 or greater than 23:59:59:29 (in 30 non-drop). Only Offset fields can have both positive and negative time values.

Timecode Entry Fields are interactive. Changes made to an entry field may effect other fields' values. For example, changes made to the In Time or Out Time fields in the Active *or* Merge Mix boxes will change the value of the Length time. Changes made in the Length field will change the value of the Out Time of both the Active and Merge Mixes. Changes made to the Offset field may effect In Times, and soon.

It is possible for the In Time and Out Time to be equal in value. When using the click/drag method of timecode entry, it is possible to scroll the Out Time downward until it matches the In Time. In that event, the Length time will be 00:00:00:00. Additional reduction of the Out Time value will also reduce the In Time value. Returning the Out Time to its original value will increase the In Time until it matches its original value.

The current system timecode is displayed in the upper right-hand corner of the OFLA screen when the Mix Viewer is enabled.

5.17.4.2 Editing Timecode Entries

Timecode Entry Fields A variety of Timecode Entry Fields are provided for the definition and control of Edit Regions, Data Regions, Data Points, and Offsets.

Timecode Entry Fields function as follows:

| | |
|-----------------|---|
| <i>In Time</i> | The starting point for an Edit Region (Active Mix), the starting point for a Data Region (Merge Mix), or the timecode address for a Data Point (Spread Source Mix or Update Snap Source Mix); |
| <i>Out Time</i> | The ending point for an Edit Region (Active Mix) or a Data Region (Merge Mix); |
| <i>Length</i> | The duration of the edit; the total time of the Edit Region; |
| <i>Offset</i> | The difference between In Times of the Active Mix and Spread Source or Merge Mixes. |

The 'In Time' and 'Out Time' entry fields are equipped with buttons that allow the capture of the current timecode address while the mix is stopped or running. Clicking on these buttons ('In' or 'Out') will enter the current address into the appropriate field.

Timecode addresses may be entered into any field using the following methods:

Timecode Capture Capture the current timecode address by clicking the 'In' or 'Out' buttons (if provided); at the point the 'In' or 'Out' button is clicked, the current timecode address is entered into the corresponding field; Timecode addresses can be captured when the mix is running or stopped.

- Click-and-Type**
- Highlight all or part of the entry field with a click (hours, minutes, seconds, and frames may be selected individually or as a group);
 - Type in the desired timecode value (colons are not necessary when typing);
 - Press Enter.

- Click-and-Scroll**
- Highlight all or part of the entry field with a click, and, while holding the trackball button, scroll the value up or down; an upward trackball motion will increase the timecode value, and a downward motion will decrease it;
 - Stop at the desired value and press Enter.

- +/- From Existing Time**
- Press the + or – key from the computer keyboard, and an additional Timecode Entry Field will appear;
 - Using one of the highlight methods above, enter a timecode value;
 - Press Enter. The math to add (+) or subtract (–) the entered value to/from the existing timecode will be applied. The result of the math will be entered as the new timecode address.

- Right-Click Menu Selection**
- Right-click any part of the entry field;
 - A menu of timecode address selections from which to choose will appear;
 - Use the click/drag method to select a timecode address included in the menu.

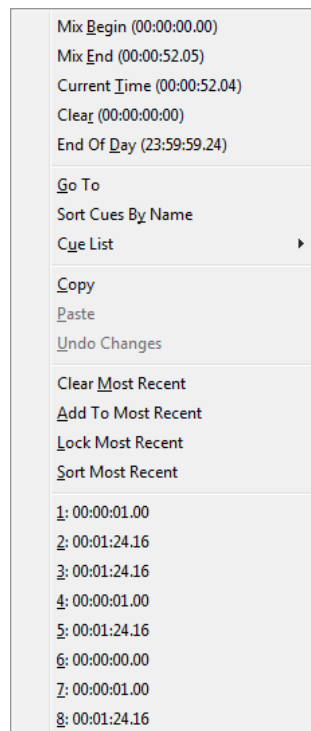

Mix/Timecode Items

- The items contained within the Right-Click Timecode Menu are as follows:
- *Mix Begin*: This is the first timecode address within the selected mix (the selected mix is the open mix that has been chosen with the tabs at the bottom of the Object Picker or Mix Viewer); clicking the ‘In’ button while holding the ISO (AUTO MODE) key performs the same function.
 - *Mix End*: This is the last timecode address within the selected mix; clicking the ‘Out’ button while holding the Shift key performs the same function.
 - *Current Time*: This is the current console timecode address.

- *Clear*: This clears the timecode entry for the selected field and resets the value to 00:00:00:00. *The Backspace key will also clear entries, however, it resets all timecode fields.*
 - *End of Day*: This will enter the last possible timecode address available. For 30 frame non-drop timecode, this value will be 23:59:59:29.
 - *Go To*: This is a transport control used when the Mix Viewer is enabled.
 - *Sort Cues By Name*: This sorts the Cue List items alphabetically by name. Items are usually displayed chronologically by timecode address. This function may be toggled On/Off, with On being indicated by a check next to the menu item.
 - *Cue List*: This displays the contents of the Cue List (if one exists) from the currently opened Title. Timecode addresses from the Cue List items may be selected using the click/drag method.
- Cue List Items**
- *Copy*: This allows the timecode address from the selected field to be copied to the PC clipboard.
 - *Paste*: This allows the timecode address from the PC clipboard to be pasted to the selected field.
 - *Undo Changes*: This restores the previous timecode value to the selected field after a change has been made.
- Function Controls**
- *Clear Most Recent*: This clears all items from the Most Recent timecode address list.
 - *Add to Most Recent*: This adds a timecode address to the Most Recent List. Timecode addresses are also added to the Most Recent list whenever a value is entered into any field (unless Lock Most Recent is enabled).
 - *Lock Most Recent*: This prevents changes from being made to the Most Recent timecode address list. This menu item may be toggled On/Off. A locked Most Recent list is indicated by a check next to this menu item. When the Most Recent list is locked, the Clear Most Recent menu item is not available.
 - *Sort Most Recent*: This sorts the Most Recent list chronologically by timecode address. Most Recent list items are usually displayed in the order in which they were entered. Sort Most Recent will re-arrange the list items with the lowest value first. This menu item may be toggled On/Off. If left On (indicated by a checked menu item), new entries to the Most Recent list will be automatically sorted as they are entered.
- Most Recent Address Controls**
- *List Entries*: This displays the contents of the Most Recent timecode address list (if one exists). Timecode addresses from this list may be selected using the click/drag method. The Most Recent list is available to all Timecode Entry Fields.
- Most Recent Address List**

5.17.4.3 Timecode Entry Controls

Timecode Entries Controls are provided that allow timecode fields to be set to zero, reset to the previous values, stored, and restored on a global basis. When these controls are used, the values for all present Timecode Entry Fields are effected. As discussed previously, the fields that are present are determined by the Edit Type selected.

The timecode entry controls (labeled Timecode Entries) are as follows:

Clear Resets all timecode values to 00:00:00:00; the Backspace key on the computer keyboard performs the same function;

Undo/Redo Toggles between Undo and Redo modes of operation; Undo resets the timecode fields to the values that were in use before changes were made; Redo restores the most recent changes;

Save Copies all timecode values to the PC clipboard;

Recall Copies the saved timecode values from the PC clipboard to the Timecode Entry Fields.

5.17.4.4 Locking Timecode Fields

Timecode Field Locks Timecode values may be locked in the Length (in the Active Mix box) and the Offset fields (used with Spread Source Mix and Merge Mix). This allows the values in the locked field(s), which might otherwise change, to remain constant when the values in other fields are changed. Locking the Length or Offset field is accomplished by checking the Lock box to the right of the field.

Locking the Length Field Locking the Length field is useful when the duration of an Edit Region needs to maintain its total time, but the In or Out Times must change. Changes made to the In Time will create corresponding changes to the Out Time and vice versa, while the Length field remains the same. Changes made to the Length field will change the Out Time field. *It is important to note that the Length field's value may be edited even when it's locked.*

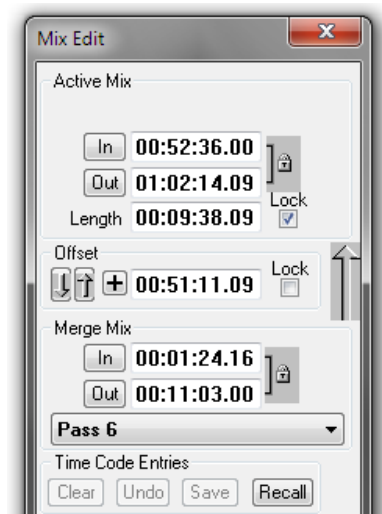

Locking the Offset Field Locking the Offset field is useful when it is desired to maintain a constant difference In Time (offset) between the In Time of the Active Mix and the In Time of a Spread Source Mix or Merge Mix. This allows fields (other than Offset), including In Time, to be changed while preserving the offset value between the mixes.

When the Offset field is locked by itself, it is possible to change its value by \pm one increment only. If the entire entry field is highlighted, its value can be changed + or - by only a single frame only. If only the seconds portion of the entry field is highlighted, the value can only be changed by \pm one second only, and so on.

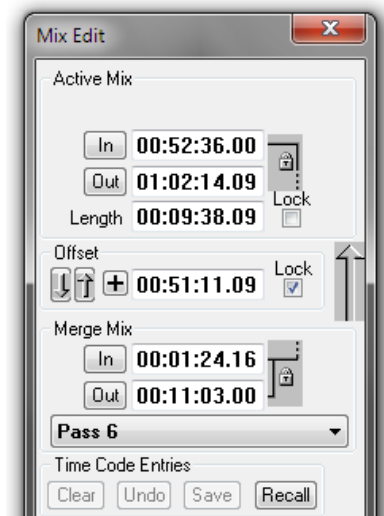

Locking the Length/Offset Fields

Both the Length and Offset fields may be locked simultaneously. This allows the Edit Region *and* Offset to remain constant when other fields are altered. In this case, it is possible to change the Offset field by more than \pm one increment.

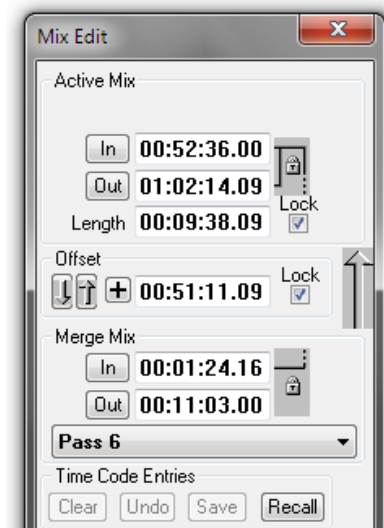

Notes To fully understand the relationships between the various entry fields and their locking capabilities, experimentation with a variety of conditions is strongly suggested.

Remember that Timecode Entry Fields are interactive, so changes to fields in one box (such as Merge Mix) may affect changes in other fields (such as Active Mix).

5.17.5 Selected Objects Display

Selected Objects Window Once channels/objects have been selected and applied using the Object Picker, a list of the chosen objects is displayed in the Selected Objects window. It is the parameter values of these objects that will be affected when the edit is performed.

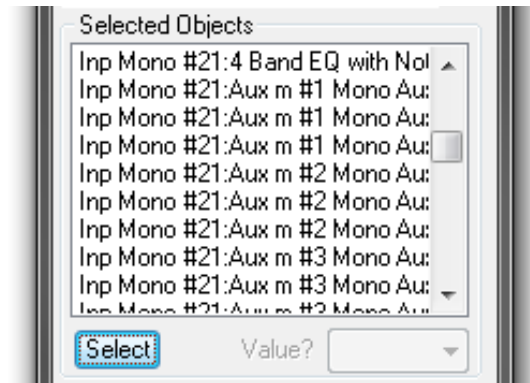

Note Selected Objects (objects and parameter values) cannot be further defined using the Selected Objects window. Channels, objects, and parameter values can only be chosen using the Object Picker.

Value Entry Field A Value Entry field is located in the lower right-hand corner of the Selected Objects combo box. It is used to enter the value to be applied when Set and Trim Edit Types are performed. This value is applied as follows:

Set Parameters selected for editing will be set to the entered value for the duration of the Edit Region;

Trim The values of the parameters selected for editing will be offset by the entered value for the duration of the Edit Region.

Note The Value Entry Field is only available in Set and Trim Edit Types.

The type of value is determined by the type of parameter(s) selected for editing. Some parameters will have specific labels for the Value Entry Field. For example, if Fader values were selected from a group of Input channels, the Value Entry Field will be expressed in dB. Likewise, if a group of EQ frequency parameters were selected, 'freq' would represent the Value Entry Field. Other parameters without specific labels will be labeled simply as 'Value.'

Note An arrow will appear at the right of the Value Entry Field when like parameters of certain types are selected for editing. Clicking on this arrow (or anywhere in the Value Entry Field) will cause a scroll box to appear that contains a list of the possible values for that parameter. For example, if Input Gain #1 is selected, the scroll box will contain values ranging from -24 to +24 dB in 1 dB increments. A value can be selected from this list by highlighting the desired item.

Parameters of the same type (such as Direct Out Level) may be chosen from several different channel types, such as Input, Group, Auxiliary Output, and so on. Mono and Stereo channels may be included when objects/parameters are chosen.

Parameters of *similar type* may be selected from *similar types of objects*. For example, ON/OFF parameters may be selected from Filters, EQ, Dynamics, Delay, and other objects that contain ON/OFF switches. However, parameters that are dissimilar may not be chosen for Set and Trim Edit Types.

Note When incompatible parameters are selected (such as Fader level and Mute), Set and Trim Edit Types are not functional and values cannot be entered. This is indicated by a ‘Grayed Out’ Value Entry Field.

5.17.6 Edit Types

General Information In order to provide power and versatility, OFLA offers seven distinct Edit Types. Each provides an edit function designed to perform a specific task.

Edit Types can be chosen by clicking the arrow at the end of the display. A list of Edit Types will be displayed. Clicking one of the Edit Types will select it for use. Edit Types can also be selected using click-drag method in the Edit Type window.

Edit Types are as follows:

Set Parameters selected for editing will be set to the entered value for the duration of the Edit Region;

Trim Data for the parameters selected for editing will be offset by the entered value for the duration of the Edit Region;

Freeze Data for the parameters selected for editing will be frozen at the In Time for the duration of the Edit Region;

Clear Data from the VMC Defaults will be applied to the parameters selected for editing for the duration of the Edit Region;

Spread Data from a single point in an external mix will be applied to the parameters selected for editing for the duration of the Edit Region;

Merge Data from a region of an external mix will be applied to the parameters selected for editing for the duration of the Edit Region;

Update Snap Data from a single point in an external mix will be applied to the parameters selected for editing for the entire mix. This is a function corresponding to ‘Update Mix Snapshot’ in the System Mix Options menu.

At Out Time Controls are provided that determine what happens to the data (for the parameters selected for editing) that exists after the Edit Region. These radio buttons are contained in the ‘At Out Time’ section of the Edit Type combo box. Only one of these options may be selected.

The functions of these controls are as follows:

Restore Values The data from the Active Mix that exists after the Edit Region is retained.

Write To End The data from the last frame of the Edit Region is written to the end of the mix.

Write To Next Change The data from the last frame of the Edit Region is written for each selected parameter until there is an original value change for that parameter in the Active Mix.

5.17.7 Offline Editing Tutorial

- Select Objects**
1. Click the 'SELECT' button in the AutoTouchPlus page in the GC.
 2. Using the Object Picker, click the channel buttons to choose groups of channels for editing.
 3. Using the Object Picker, click the object buttons to choose groups of objects for editing.
 4. Click 'Apply' to select objects for editing.

OR

1. Click the 'Show Channels>>' button.
2. Check items in the Channel Tree to choose individual or groups of channels for editing.
3. Click the 'Show Objects>>' button.
4. Check items in the Object Tree to choose individual or groups of objects for editing.
5. Click 'Apply' to select objects for editing.

- Set an Edit Region**
1. Click the 'In' button in the Active Mix box or enter a timecode address manually.
 2. Click the 'Out' button in the Active Mix box or enter a timecode address manually.
 3. Further manipulate the Edit Region as necessary.

- Select an Edit Type**
1. Using the Edit Type Menu, select the desired editfunction.
 2. Enter Set or Trim values if using those functions.
 3. Enter the necessary timecode values as required by the selected Edit Type.
 4. Click on the desired 'At Out Time' option.

- Perform Edit**
1. Click 'Perform Edit' to complete the process.
 2. Repeat as needed.

After Editing In the mix pass tree, a new Mix Pass will be created after each 'Perform Edit' function.

5.18 User Files

To help manage the multiple options available in AutoTouchPlus, the settings of all Options can be saved in a User File. The current ACU window settings and presets are also saved within User Files. This allows each engineer to save his or her own preferred settings and recall them at future sessions. This eliminates the process of manually resetting all the AutoTouchPlus Options and panel settings, adding to the ease of operation.

Beyond creating custom setups for engineers, User Files can also be used to create automation templates for specific tasks. For example, one User File might be created for music mixing, while another is created for post.

Users AutoTouchPlus supports any number of Users. For each new User a folder is created in the 'Users' folder in the D950System directory. The User folder may be named as desired. Any number of User Files may be stored in a User's folder.

Users and User Files are not specific to a particular Mix Tree, Title, or Project. Because of this, any User File in any User's folder is available for use with any Title or any Mix Pass.

Create a New User & User File

Use the following procedure to create a new User and User File:

1. Set all Options as desired.
2. Select 'Save Mix Options...' from the GC Automation menu.

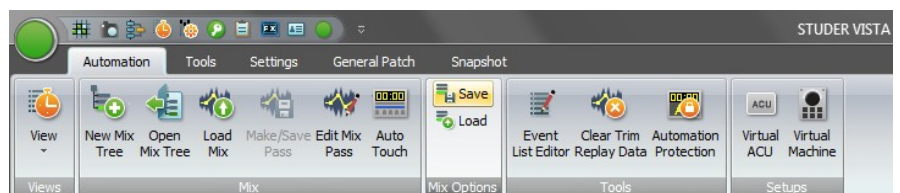

The Save User File As window will open.

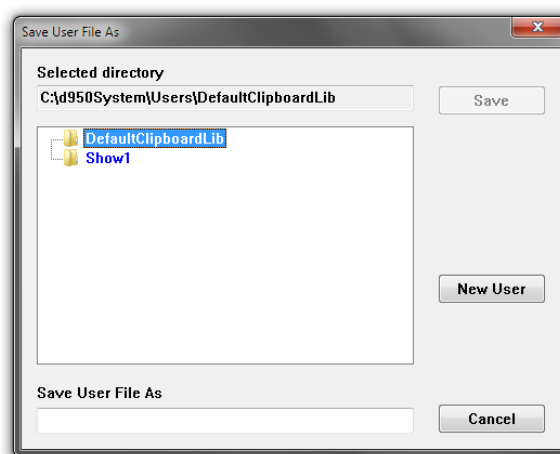

3. Click the 'New User' button. The New User window will open.
4. Enter a new User name in the field provided and click OK. A new User folder will be created.

5. Enter the name of the new User File in the Save User File As field and click OK.
6. A new User File will be created.

Load a User File

Use the following procedure to store a User File:

1. Select 'Load Mix Options...' from the GC Automation menu.

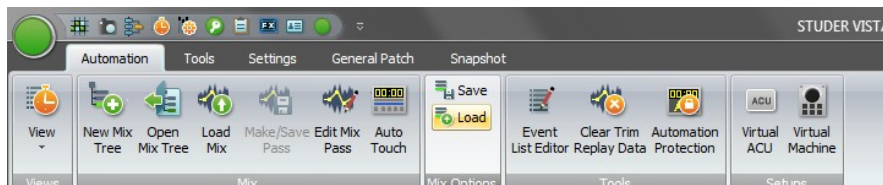

The Load User File As window will open.

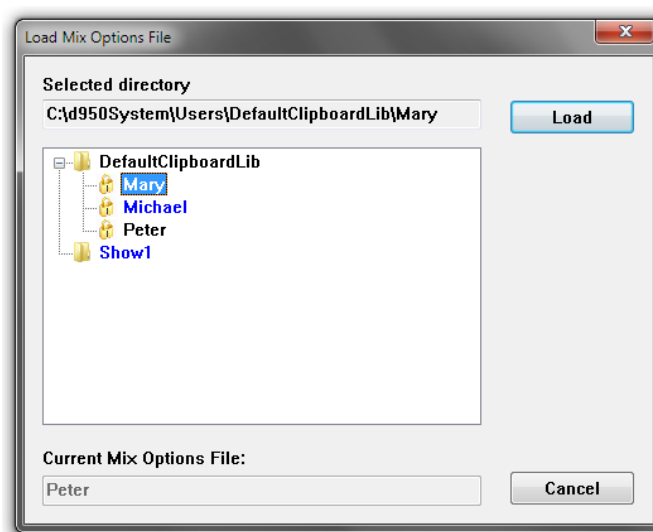

2. The User folder containing the active User File will be open and the active User File will be indicated in blue letters.
3. If necessary open the appropriate User folder by clicking the + icon for that User or double-click the name. The folder will open and display its contents.
4. Double-click the name of the desired User File or single-click the name to highlight it and then click the 'Load' button.
5. The selected User File will be loaded.

- Update a User File** Use the following procedure to update an existing User File:
1. Make changes to Options as desired.
 2. Select 'Save Mix Options...' from the GC Automation menu. The Save User File As window will open.
 3. Either double-click the active User File (in blue letters) or enter the same User name in the field provided and click OK. A dialog box will indicate a file with the same name already exists and will ask if you wish to replace it.
 4. Click YES and the chosen User File will be updated.

Delete a User or User File Users and User Files may be deleted by removing them from the Users folder in the D950System directory.

5.19 Virtual ACU Window Survey

**CONTROL MODES** (see also [chapter 5.7](#))

Read – Sets selected objects (depending on the preselector setting) into Read mode.

Write Enable – Sets selected objects (depending on the preselector setting) into **Write Enable** mode. These parameters are ‘armed’ and can be put into write (record).

Trim Enable – Sets selected objects (depending on the preselector setting) into **Trim Enable** mode. These parameters are ‘armed’ and can be put into trim (record).

Isolate – Isolates selected objects (depending on the preselector setting). These objects will not be affected by the automation.

Global **CONTROL MODES** Preselectors (see also [chapter 5.7.5.1](#))

Before any enable mode (**Read**, **Write Enable**, **Trim Enable** and **Isolate**) can be globally activated, the preselectors for the desired objects must be activated. These are:

Fdr (faders) – all faders

Mute – all mutes

Knob (rotary encoders) – all continuous controller-type encoders, except knobs used for selections

Sw (switches) – all switches

Held (held controls) – all controls that are currently in a ‘held’ state. This can be any combination of faders, mutes, encoders and switches. Refer to [chapter 5.8.3](#).

All Clr – Permits changing of all preselectors at once.

- If one or more preselectors are active, All Clr clears all of them
- If none of the preselectors are active, All Clr activates all of them.
- If All Clr *and* a global enable mode (e.g. **Write Enable**) is clicked, this brings all controls into **Write Enable** (as if preselectors were bypassed).

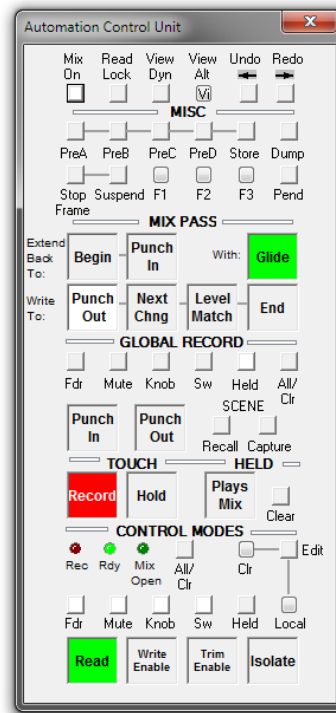

TOUCH – HELD (see also [chapters 5.8.1 through 5.8.4](#))

Record – If activated, touching a write or **trim enabled** control element (e.g. fader) will put it into record.

Hold – If activated, touching and releasing a control element (e.g. fader) will simulate a touch and hold the object even if the control has been released.

HELD – Plays Mix – When this button is engaged (see also [chapter 5.8.5.1](#)), all held controls play back their Read Mix data if not in **Record**, but the controls can be set to different physical positions.

The Read Mix data is heard, even though one or more controls are being held. This allows a held control to be pre-positioned while awaiting a punch-in. The result is true emulation of the resulting mix while the Mix Pass is running.

Clr – Clicking this button will take all held controls out of hold. It will also clear the list of controls in the held controls buffer.

GLOBAL RECORD (see also [chapter 5.9](#))

Punch In – Write or Trim Enabled controls are put into record (depending on the **GLOBAL RECORD** preselector setting).

Punch Out – Control elements currently in **Record** are punched out (depending on the **GLOBAL RECORD** preselector setting).

- GLOBAL RECORD** Preselectors (see also [chapter 5.9.1](#))
 Before globally any control can be punched in or out (Record, Play), the preselectors for the desired objects must be activated. These are:
Fdr (faders) – all faders
Mute – all mutes
Knob (rotary encoders) – all continuous controller-type encoders, except knobs used for selections
Sw (switches) – all switches
Held (held controls) – all controls that are currently in a ‘held’ state. This can be any combination of faders, mutes, encoders and switches. Refer to [chapter 5.8.3](#).
All Clr (Clear/All) – Permits changing of all preselectors at once.
 - If one or more preselectors are active, **All Clr** clears all of them
 - If none of the preselectors are active, **All Clr** activates all of them.
 - If **All Clr** and a global record command (**Punch In** or **Punch Out**) is clicked, this will affect all controls (as if preselectors were bypassed).
- (Mix Pass) Write To: (see also [chapter 5.10.1](#))
Punch Out – The automation system stays in record until Punch-out is performed.
Level Match, Next Chng, End will write the value at the time of punch-out further ahead, rather than immediately stop recording. The neutral default setting is **Punch Out**. This will record no more after punch-out.
Next Chng – The last recorded data will be applied until the next recorded change in the Read Mix data. At that point the automation will transition from record data to read mix data.
Level Match – The last recorded value will be written until it matches the read mix data.
End – The Last Recorded Value will be applied until the user-specified End Time. All previously recorded values between the Last Recorded Value (typically Punch-out) and the End Time will be erased.
Punch In – Extend the Last Recorded Value back to the punch in location.
Begin – Extend the Last Recorded Value back to the specified Begin Time.
- Glide** (see also [chapter 5.10.3](#))
Glide – Activates the Glide function.
- Stop Frame (see also [chapter 5.16.1](#))
On – Activates the stop frame automation.
Suspend – Stop Frame recording is suspended. This allows timecode to be moved backward or forward so a timecode location may be found. No control values will be written while **Suspend** is engaged.
- General Buttons** (Top Line)
Mix On (or the **Mix On** desk key) – Turns the Automation system on (see also [chapter 5.15.1](#))
Read Lock – Forces all controls into **Read** and blocks out all other controls. Nothing can affect playback of Read Mix (see also [chapter 5.16.2](#)).
Dump – If engaged when timecode is stopped, the new mix pass will not be written. To prevent a new Mix Pass from being written, click **Dump** before playback of timecode stops. (see also [chapter 5.6.1.3](#)).
Undo – Sets the Read Mix to the previous pass in the Mix Pass Stack (see also [chapter 5.6.1.2](#)).
Redo – Sets the Read Mix to the next pass in the Mix Pass Stack (see also [chapter 5.6.1.2](#)).

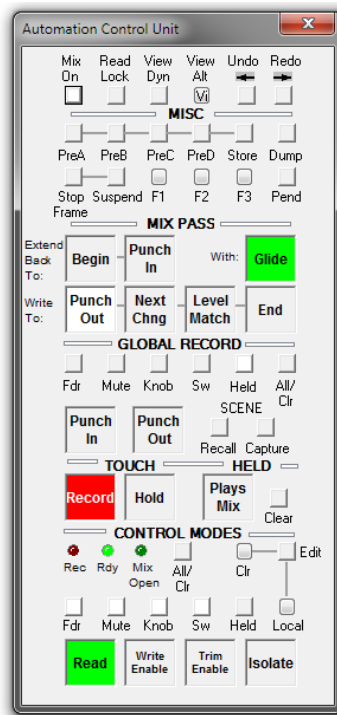

View Dyn – When held, dynamic objects are lit on the desk (see also [chapter 5.15.2](#)).

SCENE (see also [chapter 5.15.4](#))

A Scene is a global ‘snapshot’ of the automation state of each control within the system. There are two buffers in which Scenes may be stored. Scenes will be stored and can recalled during subsequent sessions.

SCENE – Capture – Clicking the **MISC** – Store button followed by a click on Capture will ‘capture’ a Scene in the first buffer. Holding ISO (AUTO MODE), clicking **MISC** – Store followed by a click on SCENE – Capture will ‘capture’ a Scene in the second buffer.

SCENE – Recall – Will illuminate when a Scene has been captured. Clicking Recall will ‘recall’ the Scene stored in the first buffer. Holding the ISO (AUTO MODE) modifier key and clicking SCENE – Recall will recall the Scene stored in the second buffer.

LOCAL / EDIT Not implemented.

OPTION A1 / A2 Not implemented.

5.20 Desk Automation Controls

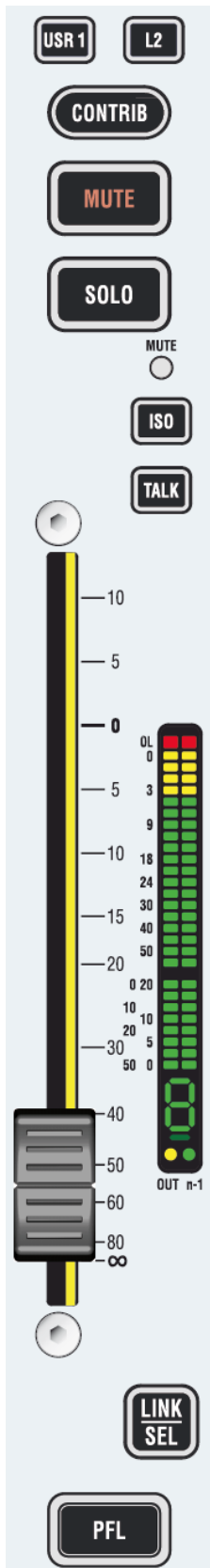

- This chapter gives an overview of the channel strip and central automation controls different from the ones found in the ACU window.
- Channel Strips** In automation mode, the channel strips hold additional functions for detailed display of the current status. There are some record indicators integrated within the recording keys.
- USR 1** Recording overview for switches. If half-lit: One or more switches are armed (i.e. in **Trim Enable** or **Write Enable** mode). If fully lit: One or more switches are recording. Pressing this key will either punch-in the held objects, or punch-out the switches currently recording.
 - L2** Current and replay value of the channel mute. If the current value is different from the one in the last mix pass, this LED indicates the value within the last mix pass, while the main red LED within the key indicates the current value.
 - MUTE** Recording of the channel mute. If half-lit: Channel mute is armed (i.e. in **Trim Enable** or **Write Enable** mode). If fully lit: Channel mute is recording. Pressing this key will either punch-in the current MUTE status, or punch it out of recording.
 - TALK** Recording of the fader value. If half-lit: Fader is armed (i.e. in **Trim Enable** or **Write Enable** mode). If fully lit: Fader is recording. Pressing this key will either punch-in the current fader status, or punch it out of recording.

Vistonics Indicators The meaning of the different Vistonics indicators is as follows:

Displayed Value The *displayed value* (e.g. ‘-7.6 dB’) is always the current value, except when the control is in TRIM mode. Then it shows the offset from TRIM null point. It is underlined whenever the control is touched (‘hold’ in automation).



Rotary Value *Current and replay value* of the rotary control. If the current value is different from the one within the last mix pass, a pink-colored element indicates the value of the last mix pass, while the main display is indicating the current value.



Fader Value *Current and replay value* of the fader. If the current value is different from the one in the last mix pass, a pink colored element indicates the value within the last mix pass, while the main display is indicating the current value.



Recording *Recording and recording mode indicator:* This always refers to the associated control.

Characters without a frame indicate the status of the rotary control (I = Isolate, R = Read, T = Trim, W = Write).

A red frame behind the W or T indicates that the rotary control is currently recording.

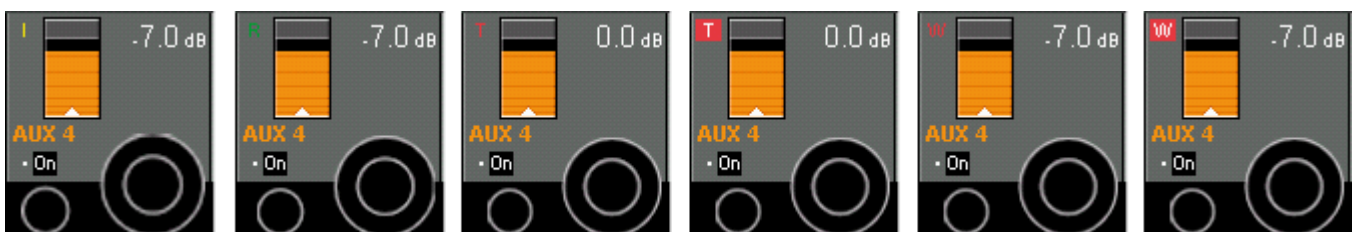

Recording *Recording mode of the fader (in the Vistonics™ generic display area):*
 Characters without a frame indicate the status of the fader (**I** = Isolate, **R** = Read, **T** = Trim, **W** = Write).
 A red frame behind the **W** or **T** indicates that the rotary control is currently recording.

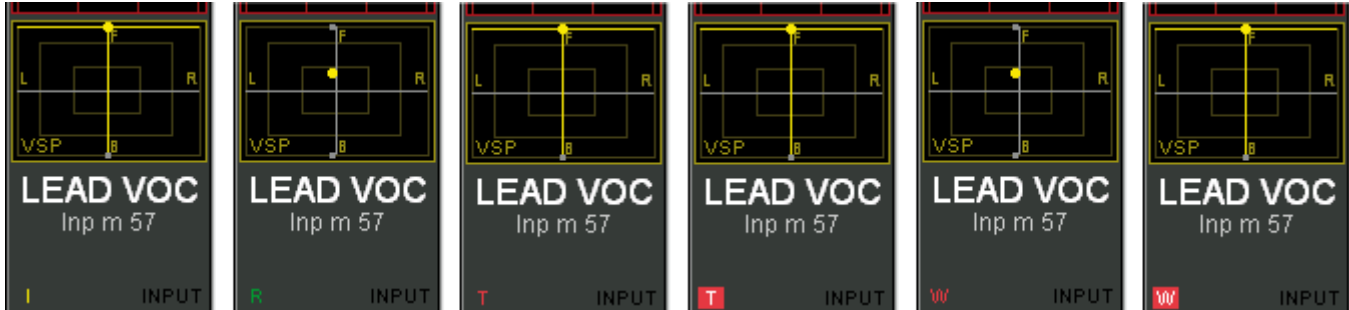

n-1 x **n-1 x** indicates that the channel is the owner of an n-1 bus, together with its bus number - e.g. 'm 1' for 'mono 1'.

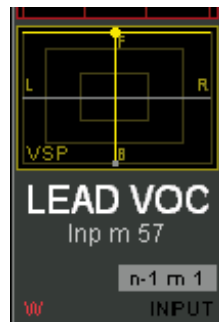

Rotary Dynamic/Static

Dynamic/static view of the rotary control:
 When clicking the View Dyn button in the ACU window, this display changes to **DYN**, if this control contains dynamically automated elements



Fader Dynamic/Static

Dynamic/static view of the fader: When clicking the View Dyn button in the ACU window, this display appears and indicates **FADER DYN**, if the fader is dynamically automated.



5.21 Auto Touch Plus Window

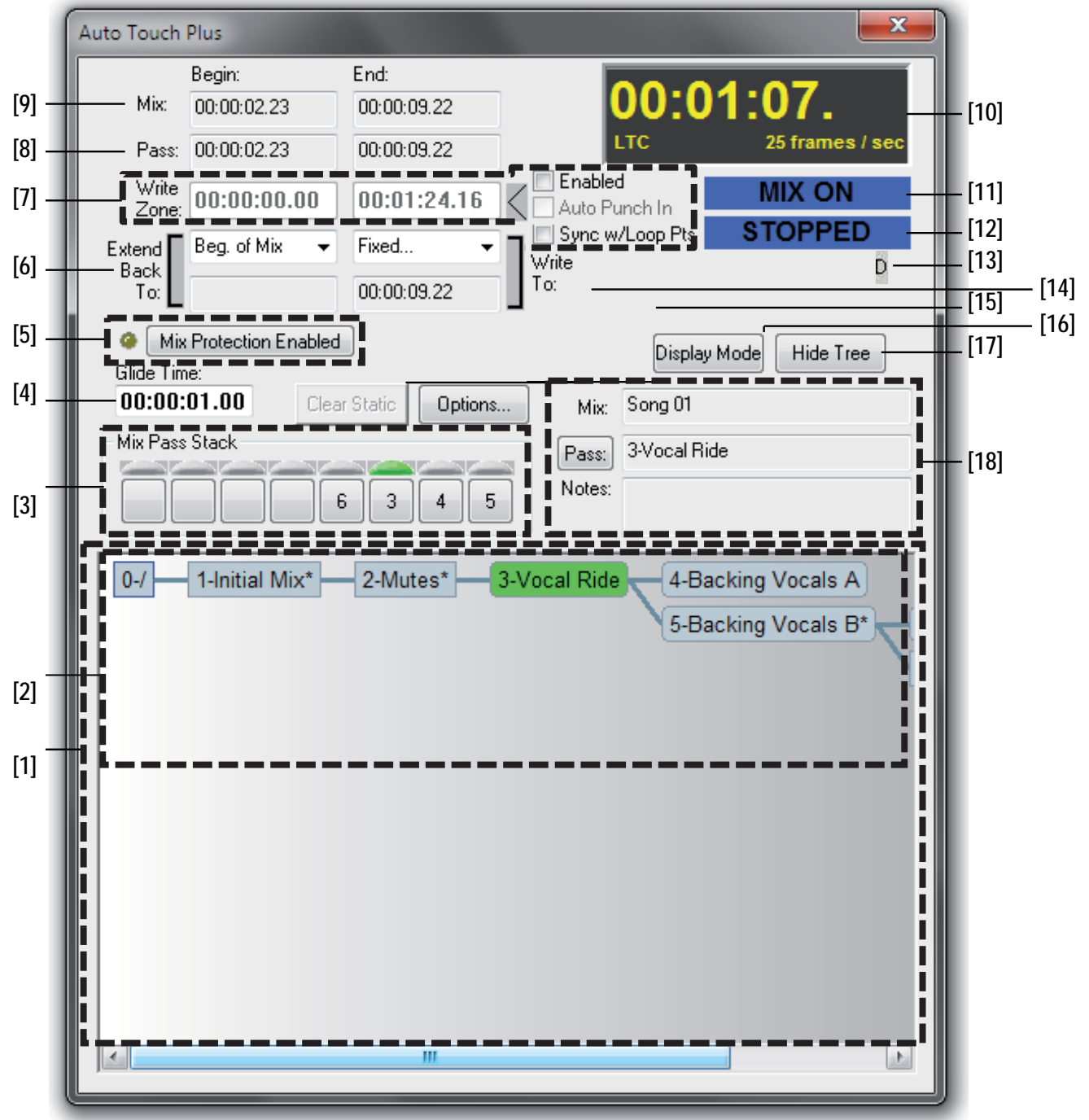

- [1] Mix Tree window. Can be hidden by clicking on the Hide Tree button. If hidden, this button turns into Show Tree, and the Display Mode button becomes inactive (refer to [chapter 5.5.1](#) for details).
- [2] Several Mix Passes are shown in the Mix Tree window. With the Display Mode button the display mode of the mix passes can be changed, and it can be decided if only the Mix Pass number, only the Mix Pass name, or both shall be displayed (refer to [chapter 5.5.1.3](#) for details).
- [3] Mix Pass Stack; holds up to eight Mix Passes for immediate use (e.g. direct comparison of Mix Passes (refer to [chapter 5.6.1](#) for details).
- [4] Glide Time; defines the length of the glide. To enter a value just click in the

- box and type the desired glide time, or use the right-click menu allowing e.g. to access the Cue list with timecode cue points (also refer to [chapter 5.10.3](#)).
- [5] **Mix Protection**; allows individual controls or a group of controls to be protected or locked-out from changes (also refer to [chapter 5.14](#)). If Mix Protection is on, the yellow LED symbol is on.
- [6] **Extend Back To: / Write To:**
In the entry box **Extend Back To:** a Fixed value, the Beginning of Time, or the Beginning of the Mix can be selected. In the entry box **Write To:** a Fixed value, the End of Time or the End of Mix can be defined.

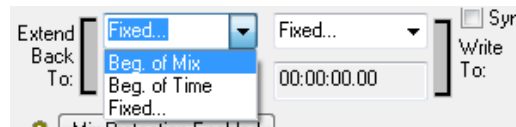

If Fixed... has been selected, an timecode entry box will be opened. Use the same method to enter a timecode as explained under point [4].

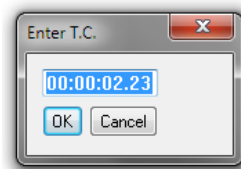

Extend Back To: can be activated in the ACU window. Either Extend back to Beg. of Mix, Beg. of Time, or Fixed... can be selected. Refer to [chapter 5.10.2](#) for more information on Extend Back To. Selected **Extend Back To: Fixed...** will be displayed in the ACU window in *red*, to indicate that this function has been activated.

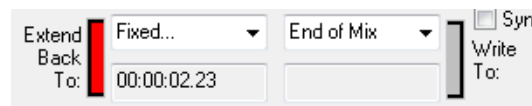

This means that automated parameters will be written back to the selected timecode value (fixed, beginning of time, or beginning of mix) in the next mix pass.

A *green* indication refers to activated **Extend Back To: Punch In**.

The entered timecode value (fixed, beginning of time or beginning of mix) is not activated.

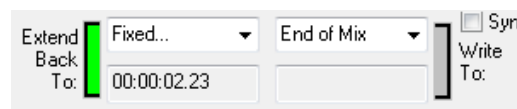

That means that automated parameters will be written back to **Punch In** time in the next mix pass.

Write To: is *red* and active if **Write To: END** in the ACU window has been selected (also refer to [chapter 5.10.1](#)).

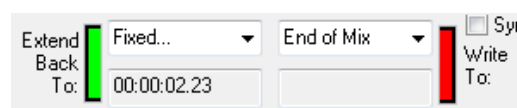

Green indicates that **Extend Back To: Punch In** will be performed and the *red* **Write to:** shows, that **Write To: END** will be performed.

- [7] Write Zone is defined by a Begin and an Endtimecode value. If activated, automation data can be written in this zone only.

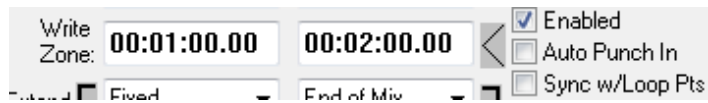

If Auto Punch In is checked, Write-enabled parameters will punched in automatically at the Write Zone - Begin, and punched out at the Write Zone - End.

If Sync w/Loop Pts is checked, the selected locator points in the machine control window will be used as Write Zone Begin and End points.

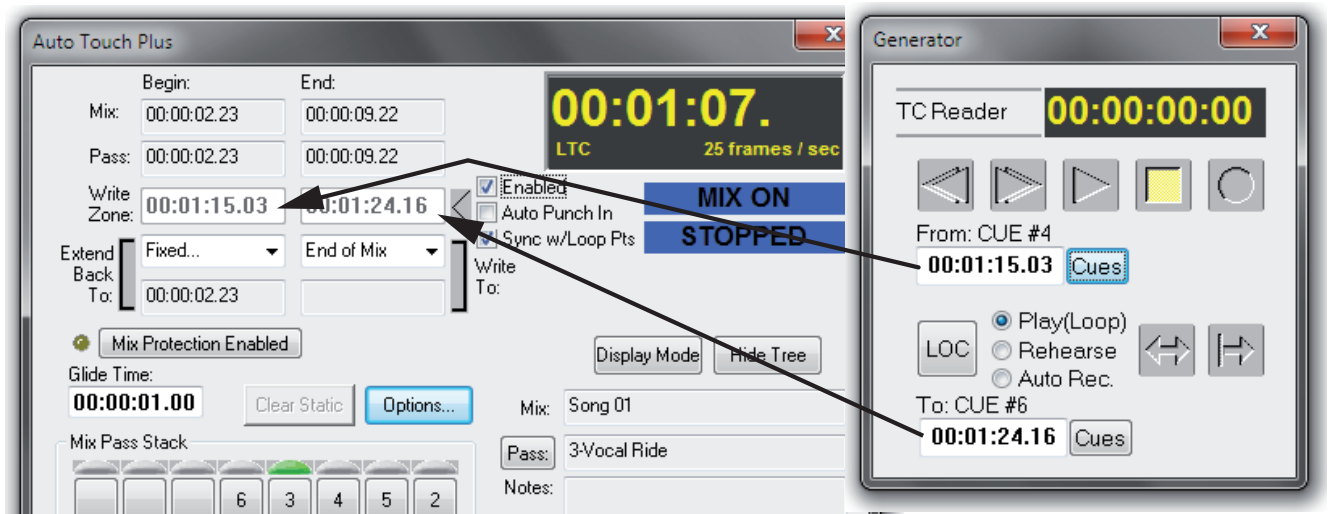

- [8] Pass; shows the Begin and End time of the current mix pass.
- [9] Mix; shows the Begin and End time of the entire mix.
- [10] The timecode window displays the current timecode (hh, min, s, frames), the frame rate, and the timecode type. Timecode type can be **GEN** (internal TC Generator), **9 pin** (serial TC), or **LTC** (external TC). These settings are made in the Option – TC Reader/Gen menu (also refer to [chapter 5.17.4.2](#)).
- [11] **MIX ON / OFF** indication (Mix On button in the ACU window or Mix On desk key).
- [12] **RECORD, READY** or **STOPPED** automation status indication.
- [13] Indication whether the parameter currently touched is a dynamic (D) or static (S) object (also refer to [chapters 5.4.1.1 and 5.4.1.2](#)).
- [14] Clear Static; when a non-dynamic parameter has been changed, this button will lit. By clicking on the button the Static Data Buffer will be cleared, otherwise the static information will be written in the next mix pass.
- [15] Options...; (only activated if **MIX** is **ON**) Click on this button to access the Mix Options (also refer to [chapter 5.22](#)).
- [16] Display Mode; mix pass display mode selection: it can be decided whether only Mix Pass number, only Mix Pass name or both shall be displayed (also refer to [chapter 5.5.1.3](#) for details).
- [17] Hide Tree / Show Tree; will hide or show the Mix Tree window.

- [18] Mix Pass information; to activate the **PASS INFO** dialog box. A name and notes can be entered for the selected Mix Pass (also refer to [chapter 5.5.1.3](#)).
- Mix: Shows the Mix Tree Name
- Pass: Shows the name of the mix pass and allows to enter the **PASS INFO** dialog box
- Notes: Shows the notes.

5.22 Mix Options

On one hand, AutoTouchPlus is a relatively simple system to use, on the other hand it has tremendous depth. Creating a system that has both of these attributes is not easy. In addition, when such a large amount of functionality is available, it is difficult to define every single transition from one mode or state to another in a precise and dictated way. There are two reasons for this:

- No two mixers will mix the same way. While one will want a feature to work this way, another equally proficient mixer will want it to work another way.
- Even the same mixer will want different functionality at different times within the mix process or based on different types of projects.

There is no right or wrong way to implement many of the functions in AutoTouchPlus. There are just different ways. So in answer to the above, there is a large number of options that affect the specific functionality of very specific modes. In total, the option set defines the specific ways in which the system will work. Each individual option, however, allows the system to have another nuance that allows the mixer to best do his or her work, in a creative and efficient manner.

Mix Option Management

A potential problem with having such a large number of options is the means to manage them all. When a mixer steps up to the console they need to be confident that the system will work in a predetermined way. In other words, they need to have ALL of the options set to a state that they have already pre set for their specific needs of the moment. AutoTouchPlus offers a system of Mix management where each mixer can have their own unlimited number of options sets, known as User Files.

Accessing Mix Options

The **Mix On** button in the ACU window (or the **Mix On** desk key) must be turned on before Mix Options may be accessed. All of the mix options reside in one convenient options dialog box which is accessed by clicking the **Options...** button of the AutoTouchPlus window.

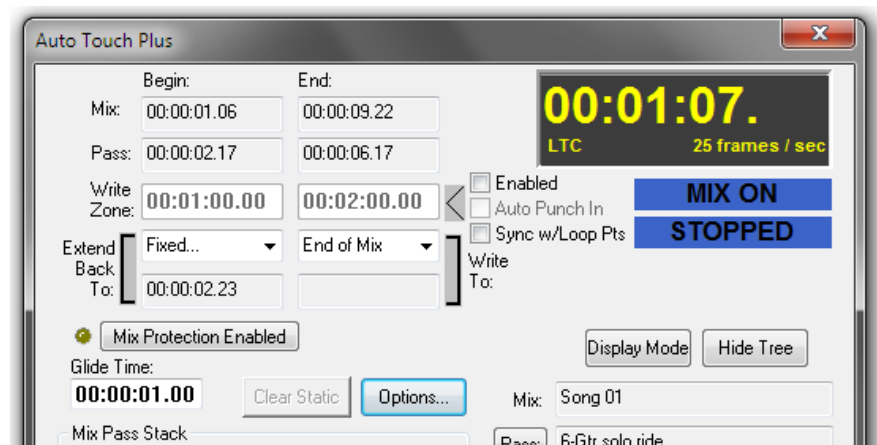

When you click the Options... button, the tabbed Options Dialog window will open. It will be set to the page where it was last left, so the options dialog tab page is said to be 'sticky.'

5.22.1 Saving/Loading Mix Options

A set of Mix Options may be saved as part of a User File and recalled at any time. Only the sections that apply to saving and recalling User Files is presented here. Users and User Files are discussed in detail in [chapter 5.18](#).

Create a New User & User File

Use the following procedure to create a new User and User File:

1. Set all Options as desired.
2. Select **Save Mix Options...** from the GCAutomation menu.

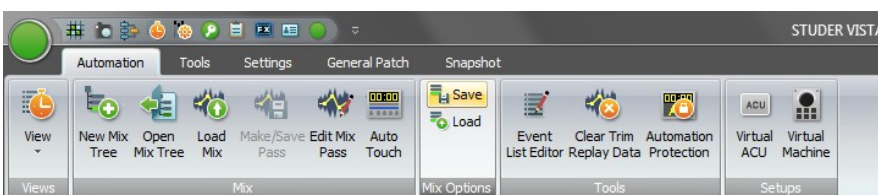

The Save User File As window will open.

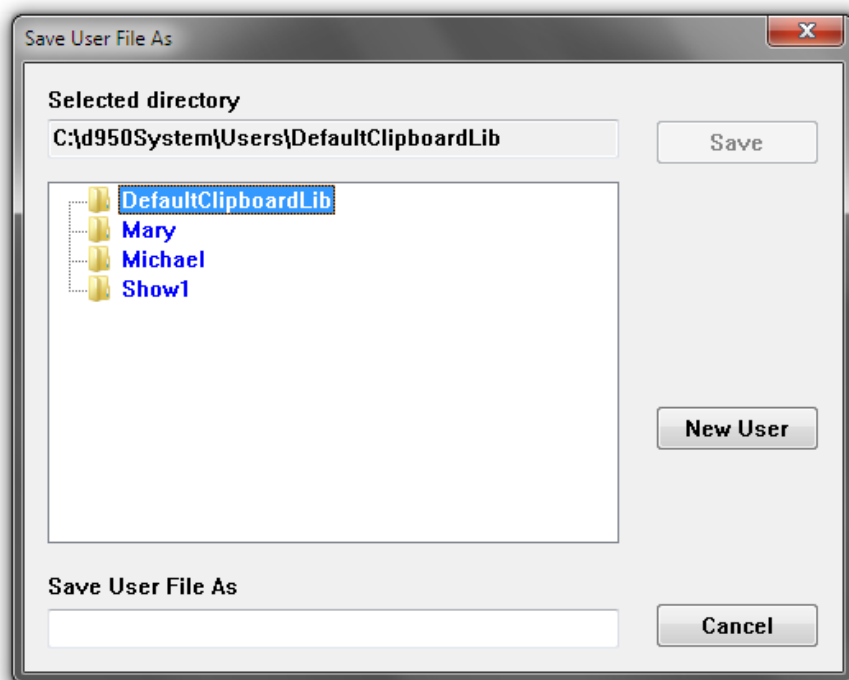

- Click the **New User** button. The **Enter New User Name** window will open.

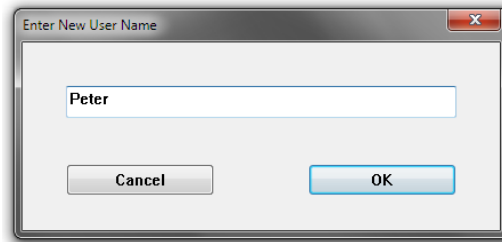

- Enter a new user name in the field provided and click **OK**. A new User folder will be created bearing the name entered.
- Enter the name of the new User File in the **Save User File As** field and click **OK**.
- A new User File bearing the name entered will be created.

Load a User File

Use the following procedure to store a User File:

- Select **Load Mix Options...** from the **GC Automation** menu.

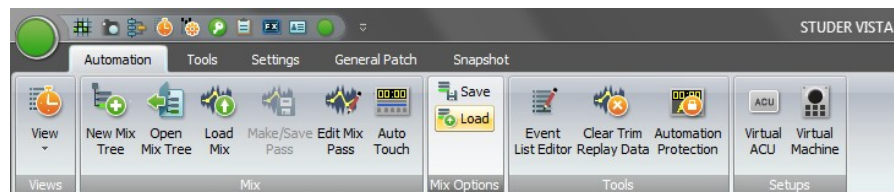

The **Load Mix Options File** window will open:

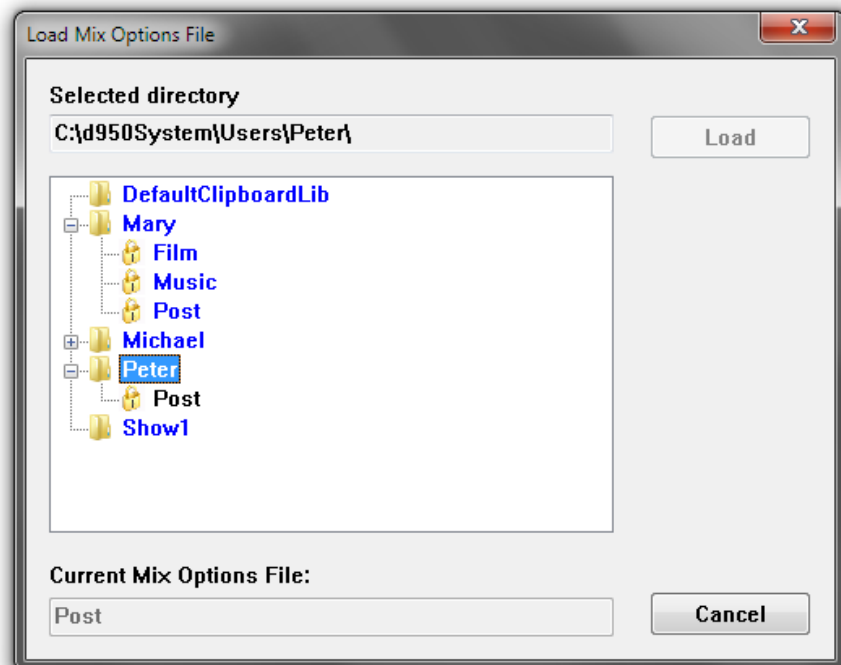

2. The User folder containing the active User File will be open and the active User File will be indicated in blue letters.
3. If necessary open the appropriate User folder by clicking the + icon for that User or double-click the name. The folder will open and display its contents.
4. Double-click the name of the desired User File or single-click the name to highlight it and then click the **Load** button.
5. The selected User File will be loaded.

Update a User File

Use the following procedure to update an existing User File:

1. Make changes to Options as desired.
2. Store any changes to AutoTouchPlus Panel Presets (if any).
3. Select **Save Mix Options...** from the GC Automation menu. The **Save User File As** window will open.
4. Either double-click the active User File (in blue letters) or enter the same User name in the field provided and click **OK**. A dialog box will indicate a file with the same name already exists and will ask if you wish to replace it.

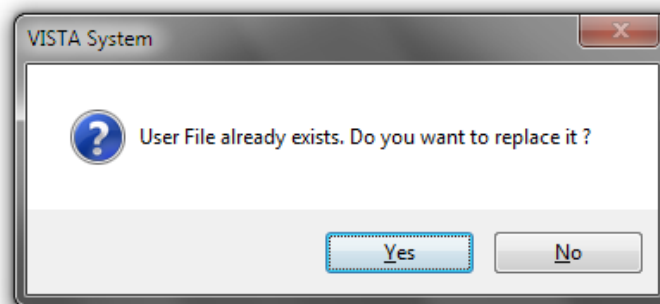

5. Click **Yes** and the chosen User File will be updated.

Delete a User or a User File

Users and User Files may be deleted by removing them from the Users folder in the `D:\950system` directory.

5.22.2 Control Mode Options

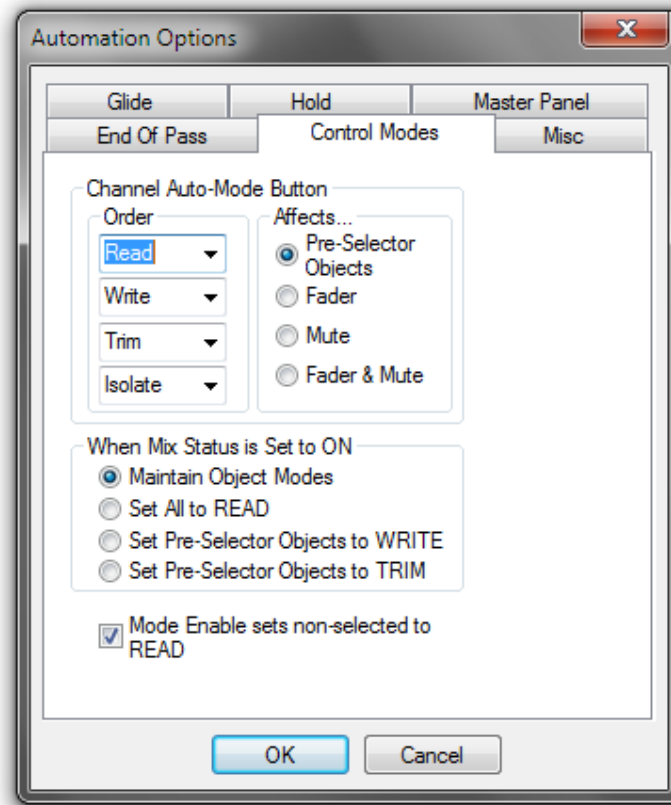

- Channel Auto-Mode Button**
- <Order>: This list selects which **Control Modes** will be selected by pressing the ISO (AUTO MODE) key, and in what order. All four **Control Modes** may be selected or not in whatever order is desired.
- <Affects>: This set of radio buttons determines which controls within the channel will be affected by the ISO (AUTO MODE) key when it is used to set **Control Modes**.
- <Preselector Objects>: The state of the **Control Modes** preselectors determine which controls will be affected by the ISO (AUTO MODE) key when it is used to set **Control Modes**.
 - <Fader>: The ISO (AUTO MODE) key only affects the fader of the channel.
 - <Mute>: The ISO (AUTO MODE) key only affects the mute of the channel.
 - <Fader & Mute>: The ISO (AUTO MODE) key only affects the fader and mute of the channel.

- When Mix Status is Set to ON**
- This set of radio buttons controls what happens when **Mix On** is turned on and off...
- <Maintain Object Modes>: In this case, turning **Mix** on or off, will not change the control modes of any of the controls in the console.
 - <Set All to READ>: In this case, turning **Mix** on after having turned it off, will set all controls to **Read**.
 - <Set Pre-Selector Objects to WRITE>: Any selected controls in the ACU **CONTROL MODES** preselector will be set to **Write**. All others are set to **READ**.
 - <Set Pre-Selector Objects to TRIM>: Any selected controls in the ACU **CONTROL MODES** preselector will be set to **Trim**. All others are set to **Read**.

Mode Enable sets non-selected to READ

Normally you can use the preselectors in combination with the **CONTROL MODES** activators to set various control types into different Control Modes. For example, you could select **Fdr** (only) and click **Write Enable**, and the faders will all go into **Write**. You could then click **Clr** and **Knob**, and then click **Trim Enable**, and the knobs will be in **Trim**, while the faders are in **Write**. This is very flexible and useful, but if you want to ensure that only specific controls are in a specific mode (like making sure that the Faders are in **Write** and everything else is in **Read**), you would have to select all the preselectors (or click the **All / Clr** button) followed by a click on **Read**. Then select **Fdr** and click **Write Enable**. However, when this option is set, you are always assured that when you click a **CONTROL MODES** activator, all controls NOT active on the preselectors will be set to **Read** when the selected controls are set to the activator mode. For example, if only **Fdr** selected on the preselector and the **Trim Enable** activator is clicked, it is assured that every control other than faders will automatically be set to **Read** mode.

5.22.3 Glide

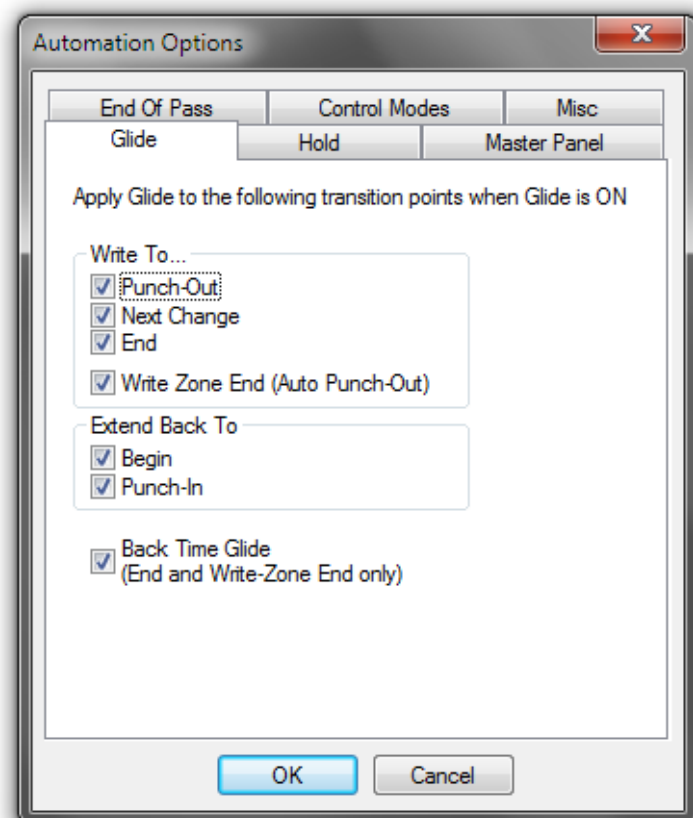

Write To... When a control is punched out of **Record** into **Read** the control will glide from the punch out value to the **Read** mix value over the time period as set by the Glide Time setting. The system attempts to recalculate the glide vector after each frame, so an attempt is made to have the actual glide duration match the set glide time as closely as possible. However, if the **Read** data is approaching the gliding control quickly, the glide duration may be shorter than the actual setting. In no cases will the time be longer. This behavior is consistent with good mixing practice.

| | |
|----------------------------|---|
| Write to... Punch-Out | <p>The Punch-Out glide will take place if the control is punched out...</p> <ul style="list-style-type: none"> • While timecode is running (glide takes place in real-time) • As a result of Timecode being stopped (glide takes place in the post process) • And even if timecode is stopped in the middle of the glide (glide takes place partly in real-time and partly in the post process). This is a great feature because there are many times when a machine (TC) is stopped by one mixer just after another mixer has punched out and a glide has begun. In this case the glide will occur unscathed. |
| Write to... Next Change | When an old Read Mix data record is encountered for this control, a glide begins at that point and extends for the duration of the glide time (of course this assumes that the option is set and that the ACU Glide button is active at the time of the next change). |
| Write to... End | When the end time occurs (either in real time or as part of the post processing) a glide begins. The glide starts at the end time if set to End of Mix or a Fixed timecode. If the glide takes place during the post process (after the mix pass is ended) then the ACU Glide button must be active at the time the Mix pass is stopped. If End is set to End Of Time, no glide occurs. (Also see Back Time Glide option below.) |
| Write to... Write Zone End | If the Write Zone is active then a glide will occur at the Write Zone End time either in real time or as part of the post process (subject to the state of the option and the ACU Glide button. (Also see Back Time Glide option below.) |
| Extend Back To: Begin | If Extend Back To: Begin is active, then a glide will occur at the Begin time (beginning of Mix or a user-input TC) as part of the post processing (subject to the state of the option and the ACU Glide button) |
| Extend Back To: Punch-In | If Extend Back To: Punch-In is active, then a glide will occur at the Punch-in time as part of the post processing (subject to the state of the option and the ACU Glide button at the time of Punch-in). |
| Back Time Glide | <p><i>(applies to End and Write Zone End only)</i></p> <p>If this option is set, then the glide will begin such that the glide <i>ends</i> at the End or Write Zone End time rather than beginning at that time. This back-times the glide so the data beyond the end time (or write zone end time) is perfectly preserved and match <i>before</i> the transition point.</p> |

5.22.4 Hold

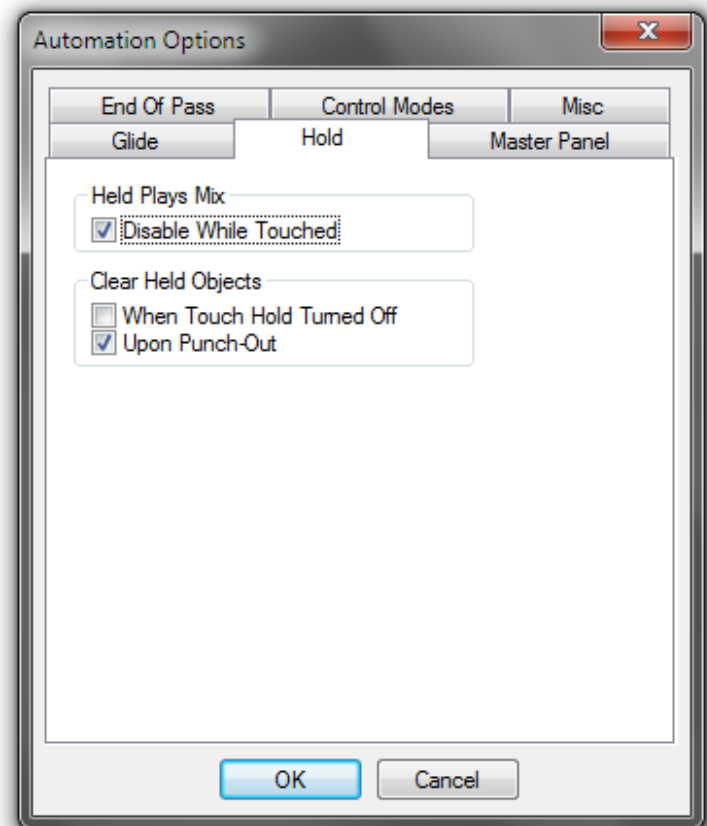

Held Plays Mix <Disable While Touched>: When **HELD – Plays Mix** in the ACU window is active, channels that are Held do not ‘play’ their held auditioned values, but play the Read Mix values instead. When this option is set, touching a control at this time disables this feature and allows a new audition (punch) value to be established by being able to listen to the Audition audio. If this option is unchecked, the **HELD – Plays Mix** function is not overridden, and the Read Mix continues to be heard.

Clear Held Objects <When Touch Hold Turned Off>: **TOUCH – Hold** (button in the ACU window or desk key) may be turned on and off during the course of a Mix pass. This options affects whether Held controls are cleared of their ‘held’ status when The **TOUCH – Hold** mode is changed from On (active) to Off. If the option is not selected, then changing the state of **TOUCH – Hold** will have no effect on Held controls.

<Upon Punch Out>: **TOUCH – Hold** is used for a variety of purposes. Sometime a write value needs to be held (so that un-touching the control while **TOUCH – Record** is engaged does not punch it out of record), just until the control is punched out of record. At that point the control would return to playing back the Read Mix. With this option set, that is how the behavior would work. However, sometimes you will want to punch-in to that same held value later in the mix pass, even after you have punched out for this section of the mix. By deselecting this option the behavior will allow for this operation. The held value will remain until it is cancelled by other means. The new Mix Pass will, of course, not be affected.

5.22.5 Master Panel

This option page allows you to over-ride certain settings of the system that are normally controlled by the ACU window. This allows for the ACU window to control functions for certain types of controls while allowing other types of controls to remain in specific modes or be blocked by them.

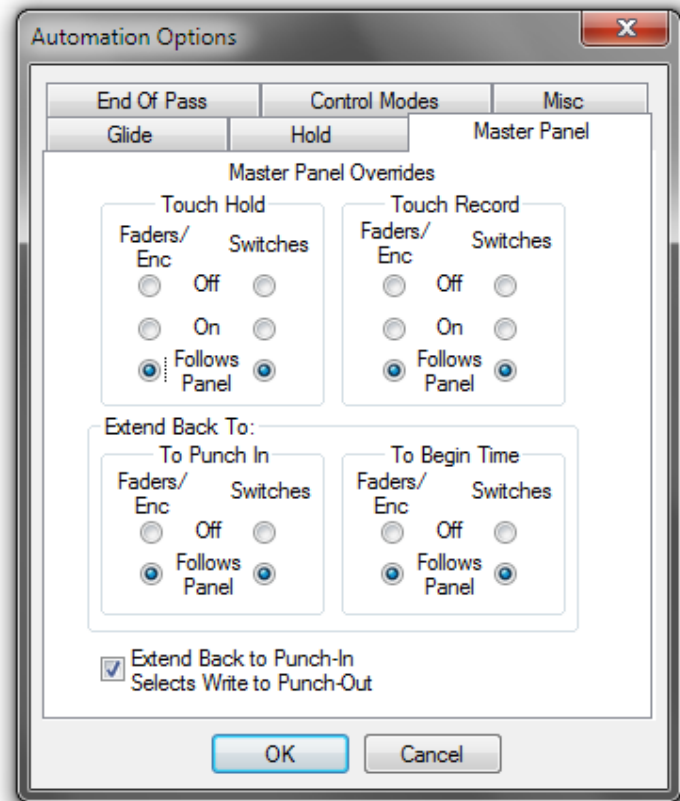

Touch Hold Faders/Enc:
 <Follows Panel>: Faders and Encoders (knobs) will follow the settings of the ACU window in regards to **TOUCH – Hold**.
 <On>: Faders and Encoders (knobs) will always be in **TOUCH – Hold** mode regardless of the settings of the ACU window.
 <Off>: Faders and Encoders (knobs) will never be in **TOUCH – Hold** mode regardless of the settings of the ACU window.
Switches:
 <Follows Panel>: Switches (keys) and Selectors (keys or knobs) will follow the settings of the ACU window in regards to **TOUCH – Hold**.
 <On>: Switches (keys) and Selectors (keys or knobs) will always be in **TOUCH – Hold** mode regardless of the settings of the ACU window.
 <Off>: Switches (keys) and Selectors (keys or knobs) will never be in **TOUCH – Hold** mode regardless of the settings of the ACU window.

Touch Record Faders/Enc:
 <Follows Panel>: Faders and Encoders (knobs) will follow the settings of the ACU window in regards to **TOUCH – Record**.
 <On>: Faders and Encoders (knobs) will always be in **TOUCH – Record** mode regardless of the settings of the ACU window.
 <Off>: Faders and Encoders (knobs) will never be in **TOUCH – Record** mode regardless of the settings of the ACU window.

Switches:

<Follows Panel>: Switches (keys) and Selectors (keys or knobs) will follow the settings of the ACU window in regards to **TOUCH – Record**.

<On>: Switches (keys) and Selectors (keys or knobs) will always be in **TOUCH – Hold** mode regardless of the settings of the ACU window.

<Off>: Switches (keys) and Selectors (keys or knobs) will never be in **TOUCH – Hold** mode regardless of the settings of the ACU window.

Extend Back To Begin Time**Faders/Enc:**

<Follows Panel>: Faders and Encoders (knobs) will follow the settings of the ACU window in regards to Extend Back To Begin Time.

<Off>: Faders and Encoders (knobs) will be blocked from entering Extend Back To Begin Time regardless of the settings of the ACU window.

Switches:

<Follows Panel>: Switches (keys) and Selectors (keys or knobs) will follow the settings of the ACU window in regards to Extend Back To Begin Time.

<Off>: Switches (keys) and Selectors (keys or knobs) will be blocked from entering Extend Back To Begin Time regardless of the settings of the ACU window.

Extend Back To Punch-In**Faders/Enc:**

<Follows Panel>: Faders and Encoders (knobs) will follow the settings of the ACU window in regards to **Extend Back To: Punch In**.

<Off>: Faders and Encoders (knobs) will be blocked from entering **Extend Back To: Punch In** regardless of the settings of the ACU window.

Switches:

<Follows Panel>: Switches (keys) and Selectors (keys or knobs) will follow the settings of the ACU window in regards to **Extend Back To: Punch In**.

<Off>: Switches (keys) and Selectors (keys or knobs) will be blocked from entering **Extend Back To: Punch In** regardless of the settings of the ACU window.

Extend Back To Punch-In Selects Write to Punch-out

In many cases it is desirable to audition a level and have that final determined level be written from the punch-in to the punch-out time. This is sometimes referred to as writing to a region. In AutoTouchPlus this is accomplished by setting both the **Extend Back To: Punch In** as well as **Write To: Punch Out**. Because this combination is selected so often, this options automatically selects **Write To: Punch Out** whenever **Extend Back To: Punch In** is selected. It is simply a convenience and ensure that when you wish to write to a punch-in/out region it is set properly. If you wish to set **Extend Back To: Punch In** with a different **Write To:** selection you can simple select a different **Write To:** selection after **Extend Back To: Punch In** has been selected (or do not set this option).

5.22.6 End Of Pass

The End Of Pass options determine the behavior of specific functions when a Mix Pass is terminated by stopping timecode. At the end of a Mix Pass each of the options control this behavior in the following manner.

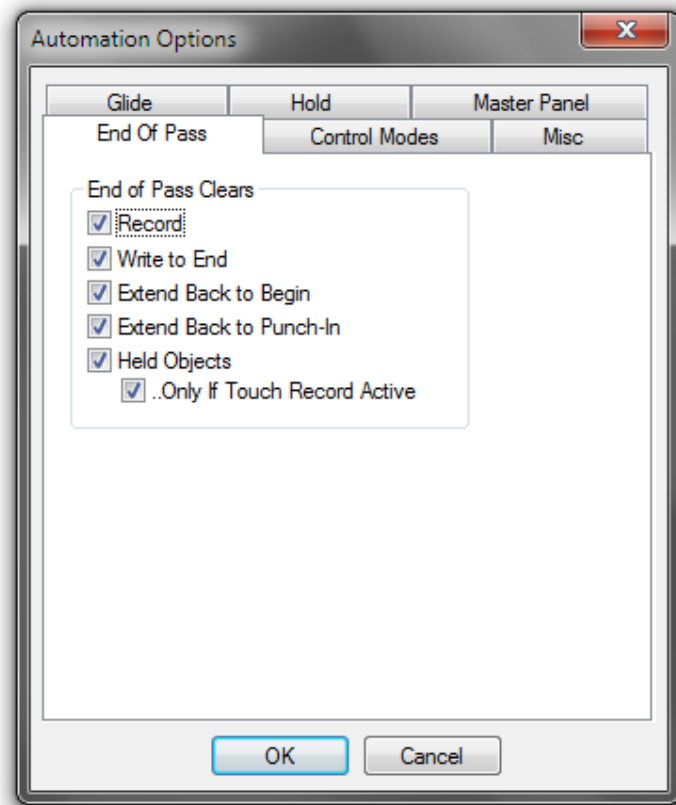

- End of Pass Clears
- <Record>: If any controls are in **Record** when the mix pass is ended they will be punched out of record if this option is set.
 - <Write To End>: Because **Write To End** is a very destructive feature (although very much used and useful), this option ensures that it is only used *for one pass* and **Write To End** reverts to **Punch In** at the end of a record pass. There will be no effect by a play pass (which is the case with all of these options).
 - <Extend Back to Begin>: Like **Write To End**, this destructive function can be set to be cleared after a record pass has been written.
 - <Extend Back to Punch-In>: Same as above.
 - <Held Objects>: There are times when you want to hold objects (in record or audition) and have them revert to playing the Read Mix data when the next pass is run. And there are times when you want to audition a level and then run the pass again to do the actual record pass. In this case, by un-checking this option the controls can be held across passes.
 - <...Only if Touch Record Active>: When checked, End of Pass will clear the items above only if **TOUCH – Record** was active.

5.22.7 Miscellaneous

This option page contains options not addressed elsewhere.

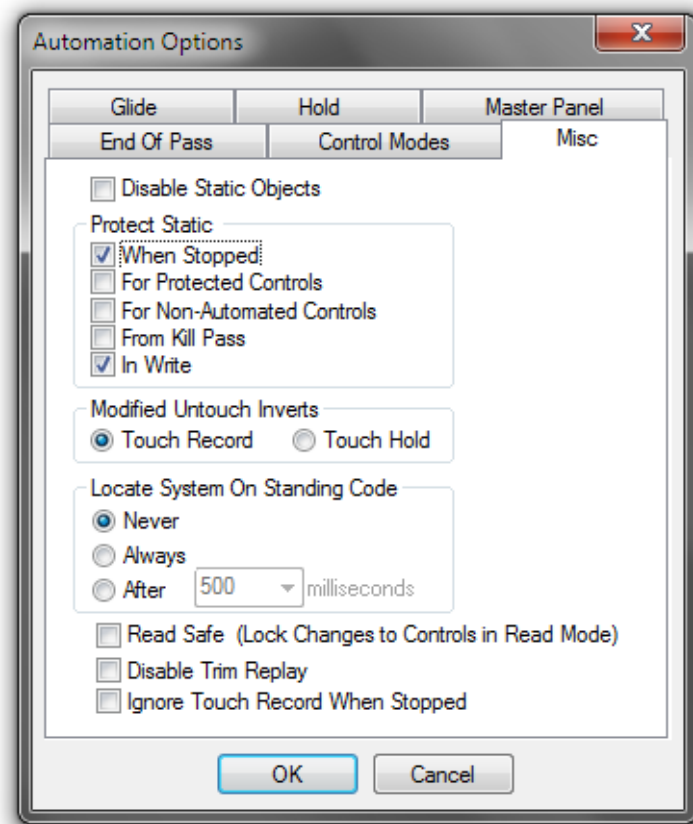

Disable Static Objects All controls will be Dynamic Objects from the start of the mix. The concept of Static Objects is then disabled.

Protect Static

- <When Stopped>: Changes to Static objects will be ignored unless the system is 'Mixing' (timecode running or stop frame mode).
- <For Protected Controls>: When a control is protected (out of scope) changes to the control will not be stored as Static values. They can be auditioned and will return to their stored value when a new Mix Pass is started.
- <For Non-Automated Controls>: Changes to non-automated objects (like Pan format) will not be stored as Static values. They can be auditioned and will return to their stored value when a new Mix Pass is started.
- <From Kill Pass>: Stored Static values are not affected by Dump (Kill Pass) operations.

Modified Untouch Inverts

- <Touch Record>: The **ISO (AUTO MODE)** key acts as a modifier key for certain functions. For example, if the modifier key is held when an enabled control is touched, the control will or will not go into record based on the inverse of the setting of the **TOUCH – Record** function (of the ACU window). Normally, when this radio button is selected, when un-touching a control, if the modifier key is held, the **TOUCH – Record** functionality is again reversed.
- <Touch Hold>: By selecting this option, when un-touching a control, the effect of **TOUCH – Hold** is reversed rather than that of **TOUCH – Record**.

Locate System on Standing Code <Never>: AutoTouchPlus will never locate to a standing timecode location.
 <Always>: AutoTouchPlus will always locate to a standing timecode location.
 <After ... milliseconds>: AutoTouchPlus will locate to a standing timecode location after the time specified in the milliseconds pull-down menu.

Other Miscellaneous Options <Read Safe>: Normally when a control is moved its changed value is able to be auditioned, and then it snaps back to the Read Mix value (unless **TOUCH – Hold** is active). When this option is set, any controls in **Read** mode will *not* be able to be auditioned. They will always follow the read mix value regardless of the physical or virtual control position.
 <Disable Trim Replay>: When this option is selected, faders will *not* play back any recorded Trim data. Note that this has no effect on the mix values that are being played from the read mix. Only that the faders will not track the any previous Trim values that were recorded. The Read Mix values already contain the effects of any previously recorded Trims. So this only affects how the faders respond when they are in **Trim Enable** mode. Also note that Trim replay is only available on faders.
 <Ignore Touch Record When Stopped>: When timecode is not running, Touch Record will be ignored.

5.23 GC Automation Menu

The GC Automation menu contains several items used in the operation of AutoTouchPlus. These menu items are referenced throughout this document and are explained briefly below.



- New Mix Tree** Selecting **New Mix Tree** from the Automation menu opens the New Mix Tree dialog window. A new Mix Tree may be created using this window.
- Open Mix Tree** Selecting **Open Mix Tree** from the Automation menu opens the **Open Mix Tree** dialog window. An existing Mix Tree may be opened using this window.
- Load Mix** Selecting **Load Mix** from the Automation menu opens the **Load Mix Into Tree** dialog window. An existing Mix from any Title may be loaded into the current Mix Tree using this window.
- Make/Save Pass** Selecting **Make/Save Pass** from the Automation menu will generate a new Mix Pass. This is useful when it is desirable to save updated Static values without having to perform a record pass.
- Edit Mix Pass** Selecting **Edit Mix Pass** from the Automation menu opens the OFLA offline mix editor. The Active Mix Pass control values and locations may be edited.
- Auto Touch** Selecting **Auto Touch** from the Automation menu opens the ‘AutoTouch+’ window.
- Save Mix Options** Selecting **Save Mix Options** from the Automation menu opens the **Save User File As...** dialog window. A new User and/or User File may be created

using this window. User Files contain Mix Options and ACU window presets.

| | |
|------------------------|---|
| Load Mix Options | Selecting Load Mix Options from the Automation menu opens the Load Mix Options File dialog window. Any existing User File may be loaded using this window. User Files contain Mix Options and ACU window presets. |
| Event List Editor | Selecting Event List Editor from the Automation menu opens the offline Event List Editor. The locations of the Active Mix Pass control changes may be edited. |
| Clear Trim Replay Data | Selecting Clear Trim Replay Data clears the Trim Replay Data for the Active Mix Pass. |
| Automation Protection | Selecting Automation Protection from the Automation menu opens the Automation Protect control window. Protection may be applied to any set of controls using this window. |
| Virtual ACU | If logged-in as Sysadmin, the ‘virtual’ automation control unit window (ACU) can be opened. |
| Virtual Machine | If logged-in as Sysadmin, the ‘virtual’ Machine Control Panel can be opened. |

5.24 Hot Keys

AutoTouchPlus software supports a variety of ‘hot keys’ (shortcut keys) that improve efficiency when operating the system. These hot keys assist in the management of timecode entry and information.

Note: This chapter assumes that the appropriate window or entry box is active. Appropriate fields or sections of fields are highlighted, and/or the cursor is placed appropriately.

Hot Key Functions Hot key functions are described in the table below.

| Key | Function |
|-------------------|--|
| Right Arrow | Next Field to the Right |
| Left Arrow | Next Field to the Left |
| Shift Right Arrow | Extend Selection one Field to the right |
| Shift Left Arrow | Extend Selection one Field to the left |
| B, b | Captures the current mix start time |
| E, e | Captures the current mix end time |
| Space, t or T | Captures current system time |
| G or g | Goto.. locates the system to the time in the control |
| C or c | Copies the FOD to a special copy buffer |
| P or p | Pastes the FOD from the copy buffer |
| R or r | Clears the timecode to 00:00:00:00 |
| M or m | Clears the Most Recently used Timecode List |
| S or s | Toggles the Sorted view of the most recently used timecodes in the context menu |
| L or l | Toggles the locking state of the most recently used Timecode List (accept or don't accept further changes taken) |
| Shift Space | Selects all fields |
| Home | Selects Hours field |
| End | Selects Frames field |
| Shift Home, End | Extends selection appropriately |

| Key | Function |
|--|---|
| Single Click | Selects Field |
| Double Click | Selects All fields |
| Delete | Zeros out selection |
| Up Arrow | Bumps Selected Field Up (if more than one field is selected it will bump by the right most field and keep the selection active) Holding Shift puts it into X10 Mode. |
| Dn Arrow | Bumps Selected Field Down (if more than one field is selected it will bump by the right most field and keep the selection active). Holding Shift puts it into X10 Mode. |
| Pg Up | Bumps Selected Field Up by 10 (if more than one field is selected it will bump by the right most field and keep the selection active). |
| Pg Dn | Bumps Selected Field Down by 10(if more than one field is selected it will bump by the right most field and keep the selection active) |
| Digit | Places the selected fields into edit mode. All unselected fields will be grayed to indicate edit mode. Once in edit mode, all digits entered will shift previous digits to the left. Most non-digit keys and trackball click activity will leave edit mode. When leaving edit mode the new timecode is checked for validity. |
| . (Period) | If in edit mode and the frames field is included in the selection it will try to justify the entered digits to the seconds field if sufficient space is available. Then it will leave edit mode on the previous selection and put the frames field in edit mode. If in edit mode but the frames field was not in the selection it will leave the digits entered as is. Exit enter mode on the previous selected fields and enter edit mode on the frames field. If not is edit mode it will select the frames field. |
| + and – (on numerical or normal keypad) as well as = is handled as + so Shift doesn't need to be held. | Used for Offsetting the timecode by another timecode. Brings up a new timecode edit box under and offset from the parent box. The Parent box goes gray. An offset can be entered into the new edit box. All normal editing can be used in the new box (bumping, scrolling etc) except for +,–. The offset can be applied to the original timecode by pressing Enter, + or –. Pressing enter will apply the offset, either adding or subtracting it based on the key used to initiate the process. Pressing + will add it (irregardless of the key used to initiate), pressing – will subtract it (irregardless of the key used to initiate). Pressing esc will cancel the action. Clicking outside the offset entry box will also cancel the action. The offset entry box will allow frames to be entered up to 99 if the HH, MM and SS fields are all 0 for bumping by up to 99 frames. |
| Ctrl and Left Trackball Button and Vertical Trackball Move | Enters Scroll Mode. The Control key is the modifier to enter scroll mode. Once in scroll mode the control key can be released. Scrolls the Field clicked on, wrapping into higher order fields. When the field and all higher order fields are 00s or Max Values the scrolling is stopped (i.e. 0 wrap is prevented). Pressing and holding the shift key while scrolling enables 10x scrolling as long as the shift key is held. |
| Enter | Commits to the Edited Timecode |
| Esc or U | Cancels all changes to the timecode since the last Commit |

Timecode Entry Validation

When free form entry of timecodes is performed, after all digits are entered or the selected field is changed, the entered data is validated. If there are invalid digits for the type of timecode, the highest order invalid field is highlighted and the text color goes red. At this point no operations are allowed until the timecode is corrected. Since the field in error is automatically highlighted, a direct entry for correction is easy.

Commit/Cancel

The timecode editor keeps two timecodes during editing, the committed timecode and the working timecode. As you bump, offset, enter digits, etc., the working timecode gets changed. Pressing **Enter** or leaving the edit box (i.e. the edit box loses focus) commits the edits. If after making changes, even in the middle of entering digits or with invalid timecode displayed in red, you can press **ESC** to cancel the changes and go back to the original timecode.

Offsets up to 99 Frames When offsetting, the add/subtract editor window will allow frames to be entered up to 99 if the hh, mm and ss fields are all 0. For example if you wanted to offset the timecode 1.5 seconds at 30 fps you could either press +, 1, 1, 5, Enter for adding 1 second 15 frames, or press +, 4, 5, Enter for adding 45 frames.

Remainder When converting from FODs to timecode strings there is the possibility of a remainder. There are roughly 100 FODs per frame. If an FOD is converted to a string and the string converted back to an FOD, any FOD between the start of the frame and the original FOD would be lost. For example, frame 00:00:00.01 starts at FOD 103. If FOD 105 is converted to the string 00:00:00.01 and the string converted to an FOD the result would be 103, losing two FODs in the process. During various operations like bumping or offsetting, the timecode conversion routine keeps track of the remainder automatically. Basically, having a remainder means that the FOD does not exactly equal the beginning of the frame represented by the timecode string. The following table illustrates the rules, regarding when remainders are saved and when they are lost.

| Action | Remainder |
|---------------------------------|--|
| User Enters any Timecode Digits | No, FOD exactly matches string entered |
| User Captures Current Time | Yes |
| Offsets | Yes |
| Bump/Scroll | Yes |
| Drag/Drop | Yes |

‘Intellibump’ When scrolling or bumping drop frame code to an invalid timecode, the control automatically adjusts to the next valid timecode. For example, if bumping seconds up two times to achieve a 2-second offset from 00:10:59.00 to 00:11:01.00, the first bump will result in 00:11:00.00. This is invalid during drop frame counting, so the control automatically sets it to 00:11:01.00. The second bump would normally bump 1 second from the previous value, which would yield 00:11:02.00. This is not what was desired. The control keeps track of artificial frame bumps required to keep true to the drop frame counting sequence and automatically re-compensates when possible. This re-compensation is attempted until the timecode is committed or some other action besides bumping or scrolling the particular field is performed. In the example above, the second bump performed would actually yield 00:11:01.00 since the control would re-compensate for the two-frame bump required to keep the drop frame rules.

CHAPTER 6

| | | |
|----------|---|----------|
| 6 | Session Configuration Tool for Infinity Cores | 2 |
| 6.1 | Installation | 2 |
| 6.1.1 | Where to Install | 3 |
| 6.1.2 | How to Install | 3 |
| 6.1.3 | Infinity Core or SCoreLive ? | 3 |
| 6.2 | Introduction | 4 |
| 6.2.1 | Features & Benefits | 4 |
| 6.2.2 | Virtual Mixing Console (VMC) Concept | 6 |
| 6.2.3 | The Practical Side | 7 |
| 6.2.3.1 | Data Compatibility | 8 |
| 6.3 | The Fast Lane – Try it! | 10 |
| 6.3.1 | Do Your Own – Use Existing or Start from Scratch? | 10 |
| 6.3.1.1 | Use an Existing VMC | 10 |
| 6.3.1.2 | Start from Scratch | 10 |
| 6.3.2 | Generate the Vista Configuration Files | 11 |
| 6.3.2.1 | Does my Console Have Enough Power? | 15 |
| 6.3.3 | Generate the Core File | 17 |
| 6.3.4 | Transfer the Files to the Console | 19 |
| 6.4 | Detailed Tutorial | 20 |
| 6.4.1 | Set Your own Workspace | 20 |
| 6.4.2 | Sampling Rate | 21 |
| 6.4.3 | Channel/Bus Page | 21 |
| 6.4.3.1 | Add / Edit Channels | 22 |
| 6.4.3.2 | Function Library | 24 |
| 6.4.3.3 | Add / Edit Buses | 25 |
| 6.4.3.4 | Special Configuration Function: Stems | 28 |
| 6.4.4 | Interface Page | 29 |
| 6.4.5 | Core Page | 31 |
| 6.4.6 | Shared Functions Page | 32 |
| 6.4.7 | Session Configuration Toolbar and Menus | 33 |
| 6.4.7.1 | Toolbar | 33 |
| 6.4.7.2 | File Menu | 33 |
| 6.4.7.3 | View Menu | 33 |
| 6.4.7.4 | VMC Tree View | 34 |
| 6.4.7.5 | Generate Menu | 35 |
| 6.4.7.6 | Window Menu | 35 |
| 6.5 | Maintenance | 36 |
| 6.5.1 | Managing the Files – Which File is Where? | 36 |
| 6.5.2 | CoreCfgTool.ini | 36 |
| 6.5.2.1 | Content of the Core Knowledge File | 36 |
| 6.5.3 | Troubleshooting | 37 |
| 6.5.3.1 | Errors and Warnings During Generate Process / In Log File | 37 |

6 SESSION CONFIGURATION TOOL FOR INFINITY CORES

The Studer Infinity Series Mixing Systems may be easily reconfigured using the Session Configuration Tool. Whereas the ability for reconfiguration is a great feature of the Studer Vista, it is important for an operator to fully understand the Session Configuration Tool and its functions. There is no safeguard functionality to prevent someone from configuring a console without e.g. the summing buses – and in such a case, the console may not function properly.

Functions, features, and appearance of the Session Configuration Tool may be changed by modifying the software. For this reason the operation of the tool and its parts as described in this manual may be slightly different from your version.

6.1 Installation

Note A good level of understanding PC basics is assumed for this installation. You may need to copy files between various media and create subdirectories.

Environment The Session Configuration Tool will run under Microsoft Windows XP, Windows Vista or Windows 7 environments.

Minimum Requirements The Session Configuration Tool requires the following minimum environment to run properly:

- Windows XP/SP2
- Intel Pentium processor (x86 compatible), 1 GHz or faster
- 512 MB RAM, 2 GB available harddisk space

6.1.1 Where to Install

The Session Configuration Tool is already preinstalled on your Infinity Series Vista console.

We recommend a second installation on a PC different than the Vista control PC. On such an offline PC, Session Configurations can be generated whilst the Vista console is used for mixing.

6.1.2 How to Install

Installing from a Compressed File Normally, when the Session Configuration Tool is provided in compressed form, you will start by copying the file (usually called `vistaX_verscfg.zip`, while 'vers' refers to the current version number of the SW release) into the target directory and then running the self-extracting file. This will decompress the original files and create the necessary directories for you. You need to extract the original files into a root directory of a drive (C, D, E, ...) on your PC.

Create a Shortcut: Usually the fastest way to use a program is to create a so-called Shortcut on the Windows Desktop. To create a Shortcut for the Session Configuration Tool, please click on the file 'CoreCfgTool.exe' in the Windows Explorer, then use the right trackball button and drag the file to the desktop. Now you are ready to run the Configuration Tool for the first time.

6.1.3 Infinity Core or SCoreLive ?

The Session Configuration Tool for the Infinity Core actually is the very same Session Configuration Tool as used for the SCoreLive (starting from SW 5.2.00). Whether it is used for the SCoreLive or for the Infinity Core is decided by some entries in the CoreCfgTool.ini file.

There are two templates of the .ini files in the folder `C:\CoreCfgTool`:

- `CoreCfgTool.sCore`
- `CoreCfgTool.ini`

`CoreCfgTool.sCore` è

This file must be renamed to .ini when used with SCoreLive systems.

`CoreCfgTool.ini` è

This file is ready to be used with the Infinity Core systems.

To doublecheck whether the correct version of the file is active, the file can be opened with a text editor and the entry 'CoreType=' can be verified.

Important All the following information in this chapter of the Operating Instructions is referring to the Infinity Core only !

6.2 Introduction

6.2.1 Features & Benefits

The Vista DSP Concept The concept of the Studer Vista allows to use multiple DSP processors in a fully scaleable and configurable way. It is possible to specify the power of the DSP core in fine steps in order to fulfil the exact need of an application. It can be said that the Studer Vista has a scaleable DSP resource pool of computing power, which can be used in many different combinations.

Session Configuration So the concept of the ‘Session Configuration’ was born which allows to create many completely different mixers that can run on the same existing hardware. The operator is now able to choose the ideal mixer for the task he or she wants to work on.

For this, the Session Configurations can be loaded and the Studer Vista console is restarted in a matter of seconds. Each Session Configuration can contain a different console configuration based on the available processing power. In the ever-changing studio environment, it is now possible to have a ‘new’ mixer every day:

| Day 1 | Day 2 | Day 3 |
|--|---|--|
| Live Broadcast Configuration | Multitrack Recording Configuration | Mixdown Configuration |
| 96 Mono Input Channels with – EQ – Delay | 96 Inline Channels with – EQ in monitor path – Comp/Lim/Exp/Gate in input path – Delay | 120 Mono Input Channels with – EQ – Delay – Comp/Lim/Exp/Gate – Surround PAN |
| 24 Stereo Input Channels with – EQ | 8 Stereo Input Channels with – EQ | 8 Stereo Input Channels with – EQ |
| 0 Multitrack buses | 48 Multitrack buses | 8 Multitrack buses |
| 16 vMix buses | 0 vMix buses | 0 vMix buses |
| 8 Groups with – EQ | 0 Groups | 16 Groups |
| 2 Stereo Master Outputs with – Output Limiter – EQ | 2 Stereo Master Outputs | 1 Stereo Master Output |
| One 5.1 Master Output with – Output Limiter | | One 5.1 Master Output |
| 8 Mono Auxiliaries 2 Stereo Auxiliaries | 4 Mono Auxiliaries 4 Stereo Auxiliaries | 12 Mono Auxiliaries 4 Stereo Auxiliaries |
| 12 N-X buses | 0 N-X buses | 0 N-X buses |

Channel Types All channels within the DSP core can be configured as Mono, Stereo or 5.1 channels. The number of channels for any channel type is defined through the Session Configuration. Moreover, any channel type can be fitted with the available function blocks from the processing library. So EQ, Delay, or Dynamics can be fitted to Input Channels, but also to Group Channels, Master Channels or Auxiliaries in any number and combination. Any combination of Auxiliary, Cleanfeed, Multitrack Routing, Audio Subgroup and Master Buses can be configured in the system.

Infinity Core Version The Infinity core is available in three different versions, each providing different processing resources :

- Core 200
- Core 400
- Core 800

- Important In order that the Session Configuration Tool knows the exact amount of processing resources that are available to build a config, it is mandatory that the correct core version is specified. This can be done with the three core version buttons in the toolbar. The chosen core version is then also reflected under ‘Shared and External’.

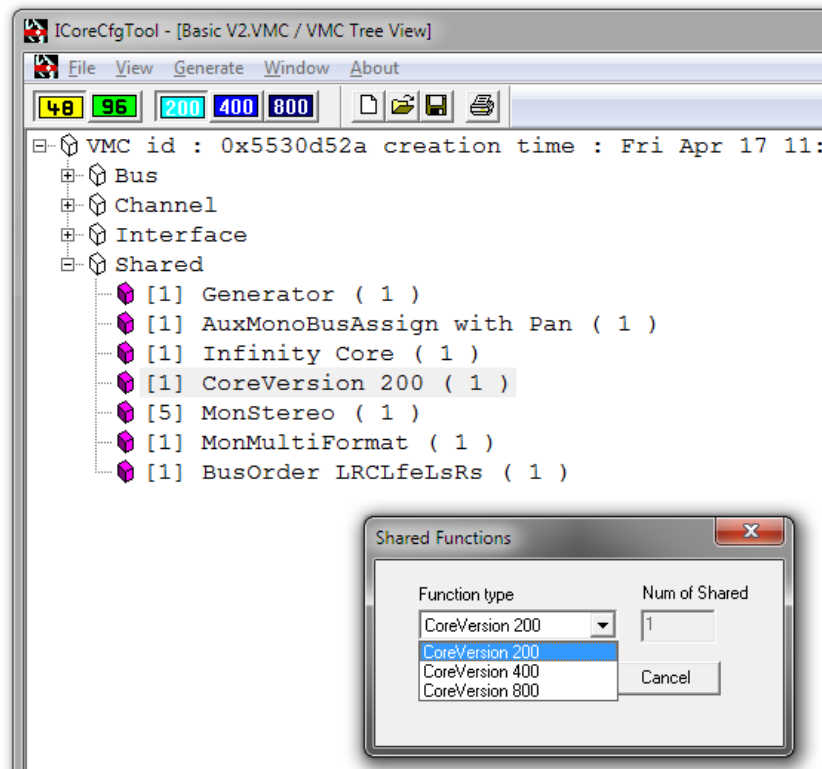

For further details about Infinity core refer to [chapter 11](#).

System Size & Numbers

The size and power of the system is therefore defined by the core type. The total processing power can be compared to a large bucket full of water (installed processing capacity). The contents of the large bucket can be distributed to four small buckets (channels with fader + EQ) or to only two medium-sized buckets (channels with fader + EQ + Dyn + Delay + VSP PAN...).

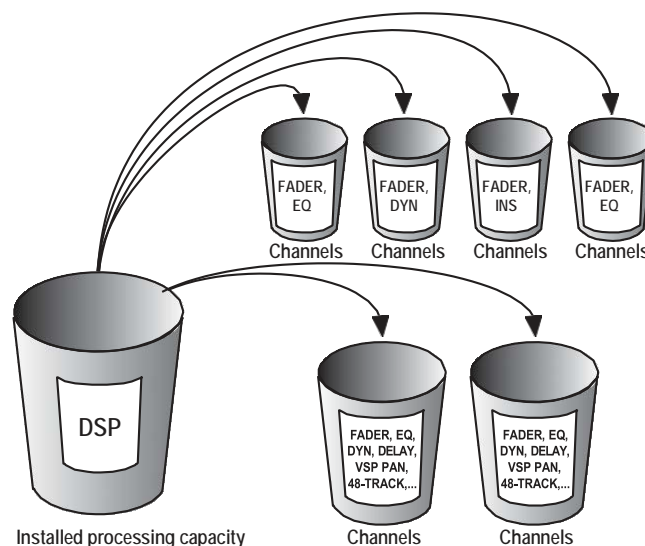

So, the number of available channels depends on two things:

- Core version (Core 200, Core 400 or Core 800)
- Load required by each of the channel types and their quantity.

To complicate matters, the total number of channels also depends on the number of summing buses and the number of physical I/O interfaces. To illustrate this, we can look at 3 different ways to use the same installed processing power.

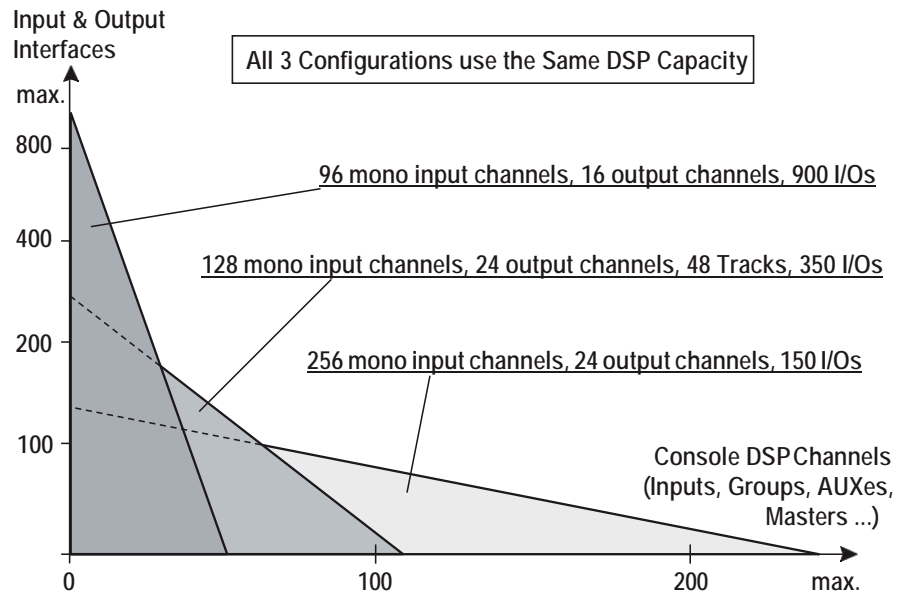

The Session Configuration Tool will tell you whether a certain configuration can be run on a Core 200, Core 400 or Core 800 version of the Infinity core.

6.2.2 Virtual Mixing Console (VMC) Concept

The Studer Vista Digital Mixing System bases its operation on the concept of a Virtual Mixing Console (VMC). The VMC is a software structure that runs on the Studer Vista control PC and consists of two parts:

- Console configuration (structure)
- Current audio settings of the console (data)

Structure The VMC describes all the parameters of a certain console configuration, such as the number of input channels, the number of multitrack buses, whether there is EQ on each channel, etc.

Data Moreover, the VMC is a real-time data container that keeps the current settings of a console, such as 'input channel 13 EQ gain = +12 dB', 'master 4 fader = -10 dB', etc. The VMC will only keep data for the channels and console parts that are defined in the structure part of the VMC. Active controls on the console, such as the faders, rotary encoders, pushbuttons and the GC keyboard/trackball control, but also the Snapshot system and the AutoTouch+Automation system can write data to the VMC. Other console parts, such as lamps, displays, and the GC screen can read data from the VMC and display them. It can generally be said that almost all settings and conditions of the Studer Vista console are a part of the VMC.

Make and Edit a Configuration

The Session Configuration Tool can be used to make a new configuration, or to edit an existing one. This is the first part of the process of preparing a VMC for the Studer Vista console. That part is done off-line, even if the Configuration Tool is running on the Studer Vista Control PC. The results of this part are:

- A 'meta' VMC file (*.vmc) – the definition of the console structure
- a XML configuration file (*.xml) – file that tells the DSP core what to do
- a MixercloudPaths file (*.txt) – a list of all parameters
- a VmcMappingInformation file (*.xml) – a mapping file
- Configuration knowledge file (*.ckf) – stores other configuration relevant information.

Use a Configuration

When we operate the Studer Vista console, we speak of 'loading a configuration'. This means loading the 'meta' VMC file to the memory of the Studer Vista Control PC. This process will remove the current file from the Studer Vista memory and load a different one. The Studer Vista Control software will then, based on information contained in the new files, run a VMC that corresponds to the information from the 'meta' VMC file. It will also remove the current processing xml file, replacing it with a new one, thus activating a new VMC. Now the Studer Vista is ready to work with the new Session Configuration.

There can only be one VMC that is active on the Studer Vista console at any one time, but there can be multiple VMCs configured and saved for later use.

6.2.3 The Practical Side

The purpose of the Session Configuration Tool is to allow creating and modifying 'meta' VMC files and generating the xml files from the information contained in the 'meta' VMC file. We call this process 'making a Session Configuration'. There are always five files that are the result of making a Session Configuration:

- the 'meta' VMC file called `MyConfig.vmc`
- the processing xml file called `MyConfig.xml`
- the MixercloudPaths file called `MyConfig-MixercloudPaths.txt`
- the VmcMappingInformation file called `MyConfig-VmcMappingInformation.xml`
- the configuration knowledge file called `MyConfig.ckf`

The name 'MyConfig' stands for any name selected by the user. The endings '.vmc', '.xml' and '.ckf' are mandatory. They are automatically created by the Tool and do not have to be typed.

It is mandatory to keep all Session Configurations in the Windows folder `C:\D950SYSTEMDB`, because both the Session Configuration Tool and the Studer Vista System software are set to search in this folder automatically. The Configuration Tool will automatically create a subdirectory (folder) within `C:\D950SYSTEMDB`, with the same name as the Session Configuration, so the folder structure may look similar to this:

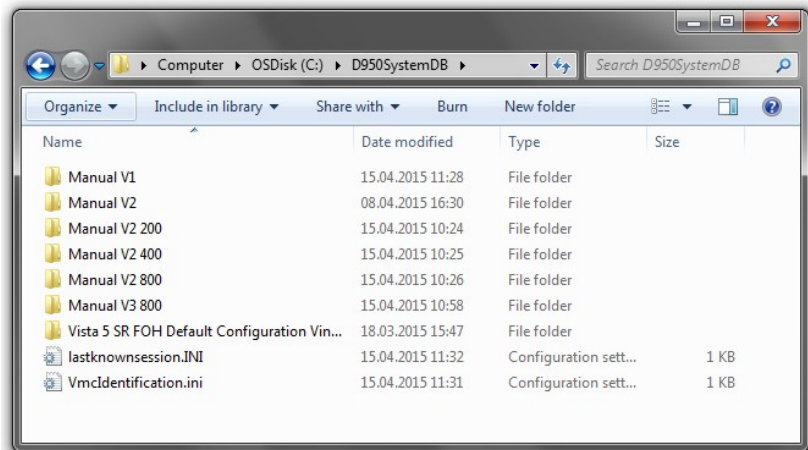

When the generation process is finished each of the subdirectory folders will contain the following files and folders:

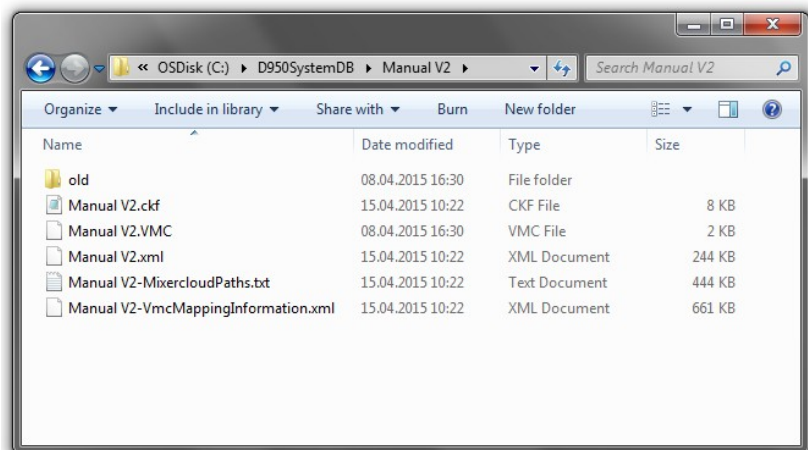

When editing a configuration, the 'old' folder is generated automatically, in order to store the last configuration.

On a Separate PC

If you are running the Session Configuration Tool on a separate PC, you will need to transfer the configuration files to the Studer Vista control PC. Since all files are Windows files, it is a simple matter of using a transfer medium (USB stick, LAN) to transport the files. Care has to be taken to store the files under the appropriate directory on the Studer Vista control PC as described above.

The best practice is to always copy the whole folder <MyConfig> with all files inside and paste it to the C:\D950SYSTEMDB directory.

It is not necessary to copy the *.ckf file. It is not used by the Studer Vista. It is generated for maintenance reasons only.

6.2.3.1 Data Compatibility

Studer Vista features such as Snapshot, AutoTouch Automation, etc. use Windows compatible files to store data. Since the contents of such files are dependent on the current configuration, each file is internally stamped with the Session Configuration ID. The configurations may be quite different – the resulting snapshot or automation files will be different, too.

A Snapshot file made under Session Configuration A can not, therefore, be directly recalled under a different configuration B. A function called Import

must first be performed using the appropriate controls within the GC. For more information on the Import function, please consult the Vista Operating Instructions.

Import Rules

A simple set of rules will apply for the import:

- Unnecessary data are truncated
- Only items of identical type can be imported, e.g. data for mono input channels can only come from mono input channels
- If the source configuration A has 48 mono input channels and the current configuration B has only 32, just the channels 1 through 32 are imported and the rest of the source channels are ignored. When the item is saved it will have 32 channels in it.
- If the source configuration A has 32 mono input channels and the current configuration B has 48, just the channels 1 through 32 are imported and the rest of the current channels are ignored. The user can edit and save channels 33-48 manually. When the item is saved it will have 48 channels in it.
- The same rules apply to the existence of processing blocks (EQ, Dynamics, etc.).

6.3 The Fast Lane – Try it!

6.3.1 Do Your Own – Use Existing or Start from Scratch?

6.3.1.1 Use an Existing VMC

Usually the changes that need to be made to a configuration are small. Adding two more AUXes or replacing the mono input channels by stereo input channels may be two examples of such small changes. In such cases, an existing *.vmc file can be loaded and modified. For the first try you can use the *.vmc file that was delivered with your console as a starting point.

The *.vmc files can be treated in a similar way as word processing documents. They can be opened, saved, saved under a different name, moved and deleted.

 **Tip** Please be careful to first save the file under a different name in order to keep the Studer Vista basic configuration intact! Use the Save As item in the File menu.

Modifying the *.vmc file that had been delivered with your console is the simplest way to create a configuration that will run properly on your existing Studer Vista console. On your console, there are several things that can not simply be changed by editing the configuration:

- All external I/O wiring
- Monitoring wiring and monitoring configuration
- Signaling (fader start, ...) wiring and configuration

It is not very likely that you will be changing any of the above all the time – that is why you will want to use the existing configuration as a starting point for your work, without having to think of configuring the right I/O every time.

 **Tip** It could be that you want to change the sampling rate of an existing configuration. Just hit the according button on the toolbar, and you are done. The Configuration Tool will prompt you about functions which are not supported under the selected sample frequency. It says, that they are not supported and therefore will be removed automatically.

Note : Currently for the Infinity core, only the sample frequency 48 kHz is available.

6.3.1.2 Start from Scratch

It is sometimes handy to find out which Core version (Core 200, Core 400 or Core 800) would be needed for a certain configuration. You can always configure the mixing console of any description by starting with an empty (New) *.vmc file. For this, you will use the File/New menu. The approach of starting from scratch will be useful if you do not have to modify an existing console, but are really starting a new project.

The first thing you need to do is selecting the sample frequency. The default value is 48 kHz. The buttons on the toolbar show the selected value.

 **Tip** If you want the new configuration to really run on your existing console, you need to be careful to think of all the elements of a configuration – channel numbers and types, summing buses, I/O configuration, shared functions, etc. Otherwise your new configuration may not be able to be loaded properly on an existing console.

6.3.2 Generate the Vista Configuration Files

In this chapter, a simplified but complete configuration exercise is described. The example *.vmc file will be used as the starting point and modified. A *.xml file will be generated. You will need to start the Session Configuration Tool first.

Open the File Use the 'File/Open' menu or the 'open folder' icon in the toolbar to open a *.vmc file.

Save VMC as... To keep the original file intact, use the 'Save VMC as...' command from the File menu. Note that you do not have to type the extension .vmc. A new folder and a new *.vmc file will be automatically created.

View the Configuration Use the 'View/Channel Bus' command from the menu bar to display the configuration contents. You may want to maximise the window in order to see all the components.

This is a display of all the configured channel types and numbers and all the configured summing buses as well as their interconnections:

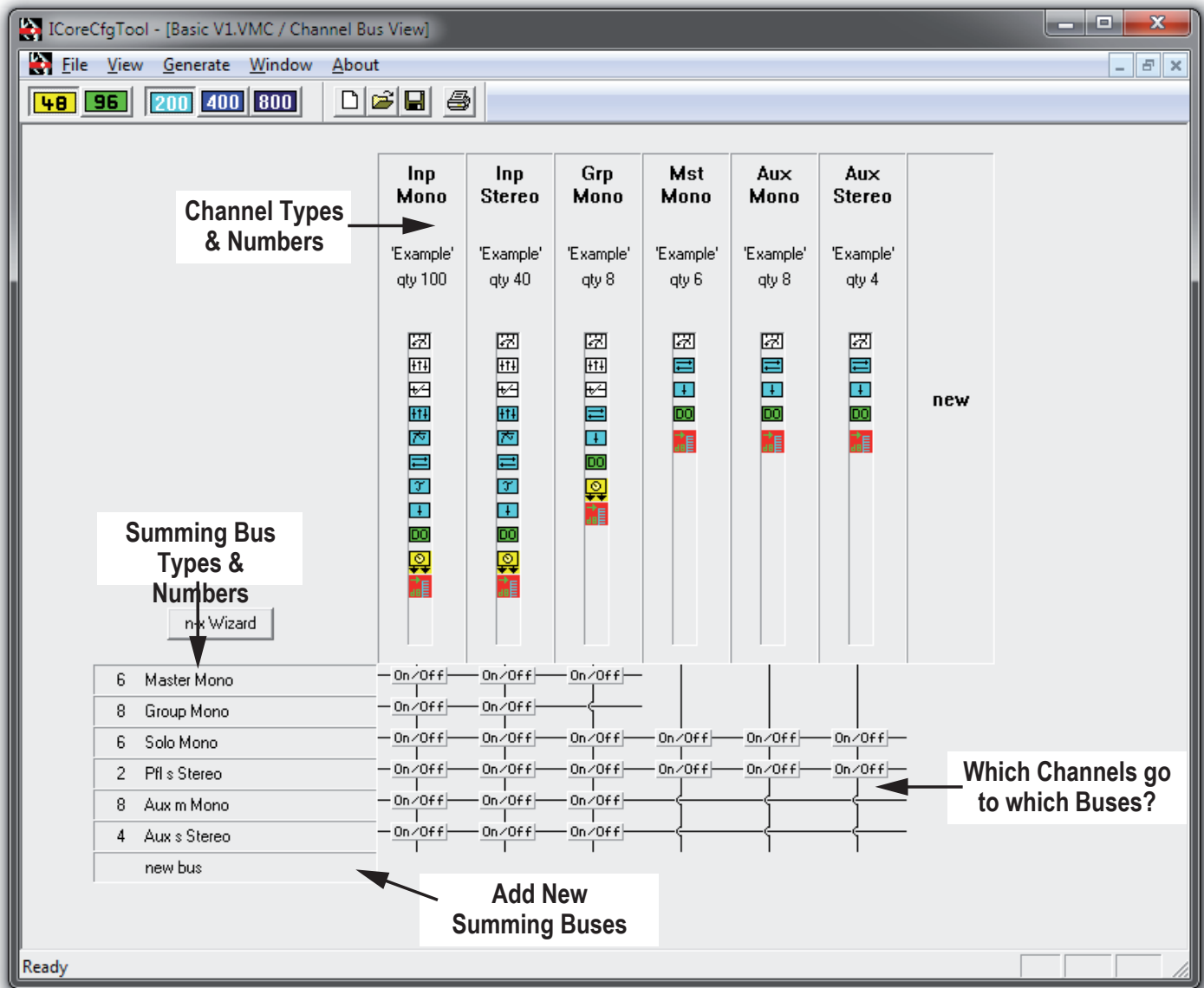

As you can see, this configuration is for a console that has:

- 100 mono input channels
- 40 stereo input channels
- 8 mono groups + 8 group buses
- 6 mono masters + 6 master buses
- 8 mono Auxes + 8 mono AUX buses
- 4 stereo Auxes + 4 stereo AUX buses
- 6 SOLO buses
- 1 stereo PFL bus

Add More Channels Double-click on the channel area labeled ‘Input mono’. This will open an editing dialog box which will allow you, among other things, to change the number of mono channels:

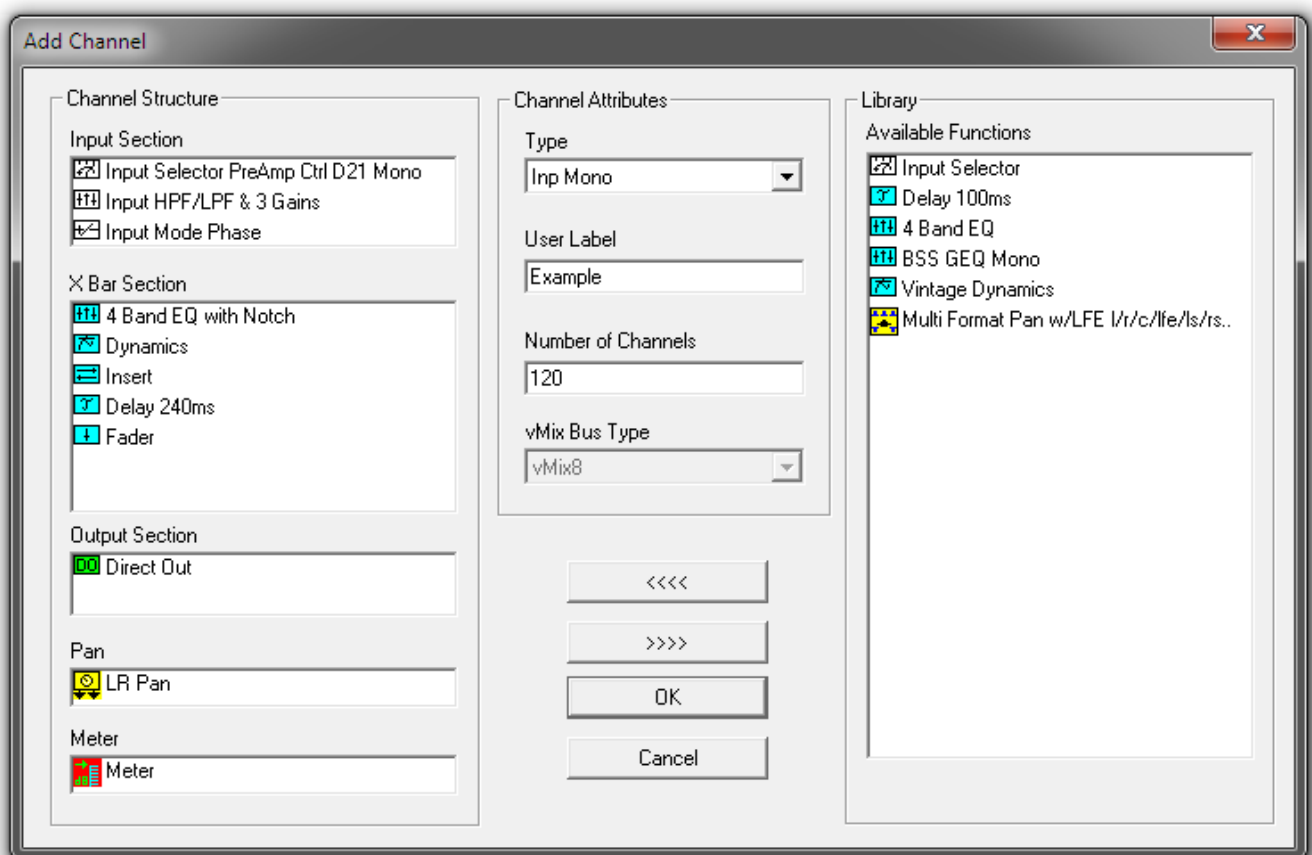

Go to the ‘Number of channels’ area and change the number from 100 to 120. Click on OK. Now you have increased the number of mono input channels to 120.

Edit the Stereo Input Channel

Now we will change the stereo input channel configuration and name. Double-click on the channel area labeled ‘input stereo’. On the left-hand side, in the area called ‘X Bar Section’, double-click on ‘Dynamics’ and on ‘Delay 240 ms’. This will remove those two functions from the stereo input channel. Now move to the area called ‘Library / Available Functions’ and double-click on ‘Delay 100 ms’. Then go to the ‘User Label’ field and type in ‘my stereo’. Click on OK.

Add More AUXes Now we will add two more mono AUX masters. Double-click on the channel area labeled 'AUX mono' and change the number of channels to 12. Click on OK.

Now you will have to adapt the number of AUX mono buses to reflect the above change. Double-click on the area labeled 'Aux m Bus'.

This will open a dialog that will allow you to set the number of buses to 12, matching the new number of AUX mono channels.

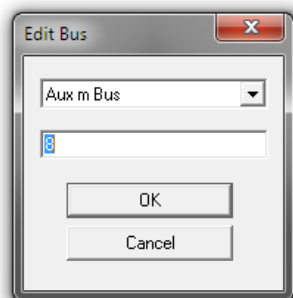

Enter '12' instead of '8' and click on OK. This will add four more AUX mono buses to the system. (alternatively, if you double-click on the area 'new bus' and select Aux mono - the system will automatically suggest the four missing Aux mono buses)

Add New Group Channels Now double-click on the channel area labeled 'new'. This will allow you to select a channel type and set its contents and number. Click on 'Channel Attributes / Type' and select 'Group mono'.

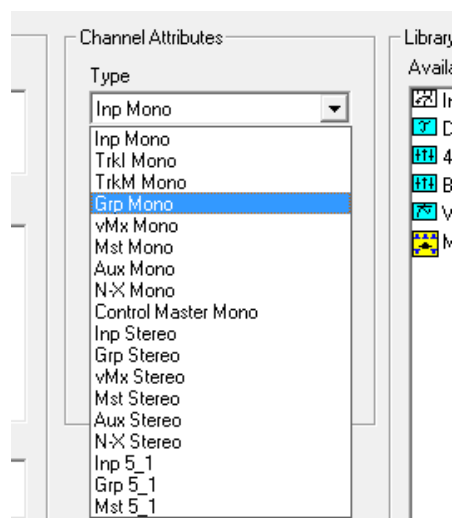

This will select the channel type to mono group. Set the 'Number of channels' to 2. Add '4-Band EQ' from the library by double-clicking on this item. Type in 'my GRP' in the user label area and click on OK. This will add two more audio groups including EQ to the configuration. Note that you now have two sets of mono group channels with completely different audio processing sections called 'my GRP' and 'Example'. Note also that the bus connections have been extended with the small 'on/off' boxes indicating that the two new groups will have access to Master, Solo, PFL and AUX buses. By clicking on the 'on/off' box corresponding to the Master Bus, you can disable access from the new groups to the masters – so they can only be used for direct outputs.

Finished? Not quite. We still have to increase the number of Group Buses to a total of ten.

- ☞ **Tip** It is legal to have more buses than corresponding channel types. The reason for this is that the buses (unlike in analog consoles) are valid audio signals and can be used as such in the Studer Vista patch. They are simply summation buses which will output the sum of all assigned inputs.

The newly edited configuration now looks as follows:

- 120 mono input channel
- 40 stereo input channels with changed processing
- 8+2 mono groups, different processing + 10 group buses
- 6 mono masters + 6 master buses
- 12 mono Auxes + 12 mono AUX buses
- 4 stereo Auxes + 4 stereo AUX buses
- 6 SOLO buses
- 1 stereo PFL bus

Check the Interfaces We will assume that for this example, the interfacing does not need to be changed. We will only have a look at what interfacing is available in the configuration we just changed. For this purpose, select 'Interface' from the 'View' menu.

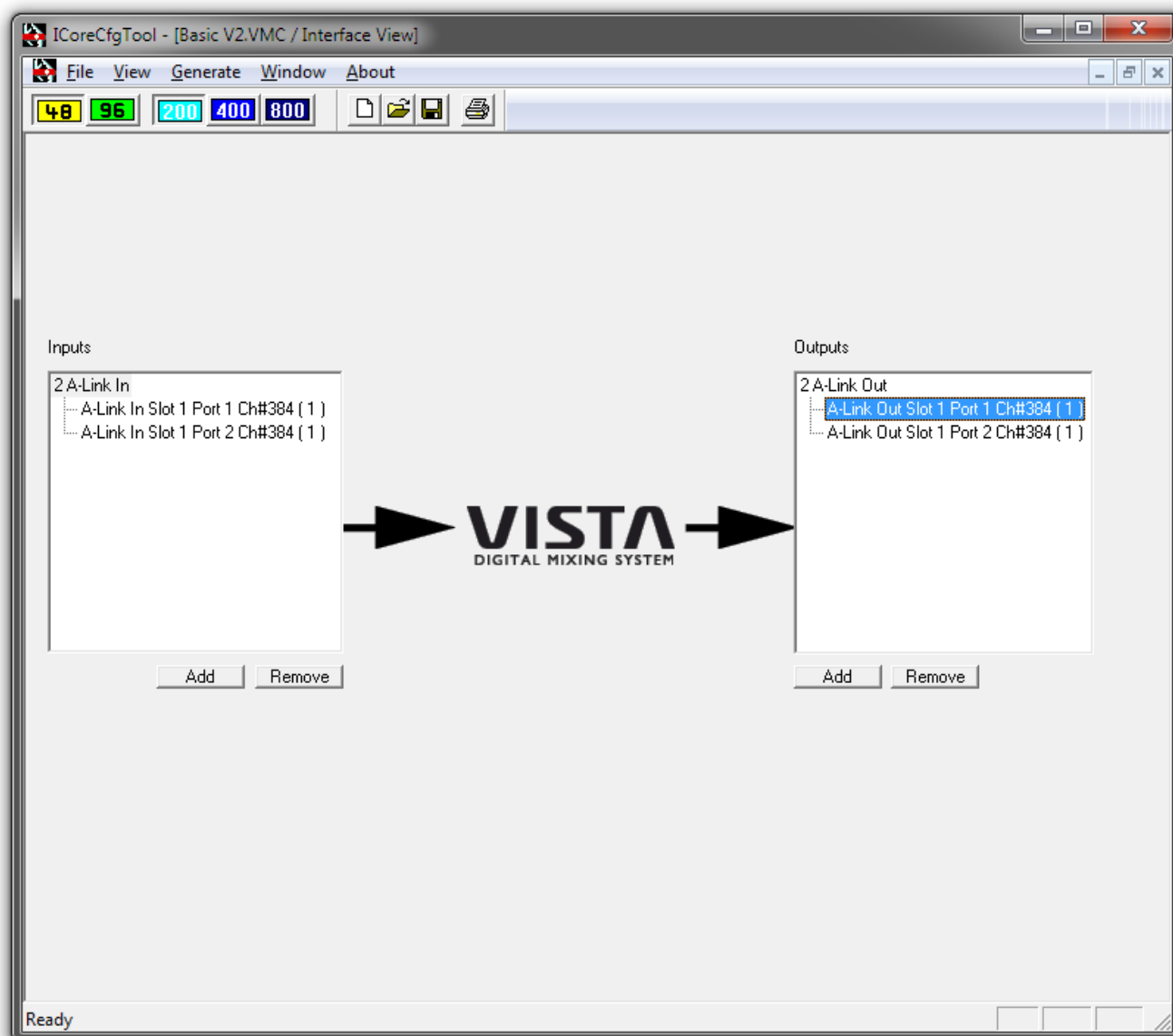

There are *two* A-Link input interfaces with 384 configured channels, and *two* A-Link output interfaces with 384 configured channel

Tip Although we have been through many actions and have edited the original configuration quite a bit, we did not yet touch on all possibilities of the Configuration Tool by far. Please read on and acquaint yourself with all the details before you attempt to make a configuration and load it on your console.

6.3.2.1 Does my Console Have Enough Power?

In order to see the console statistics, now select 'Core' in the 'View' menu. This will display the statistics of the channels, buses and I/Os, as well as the usage of the available processing resources.

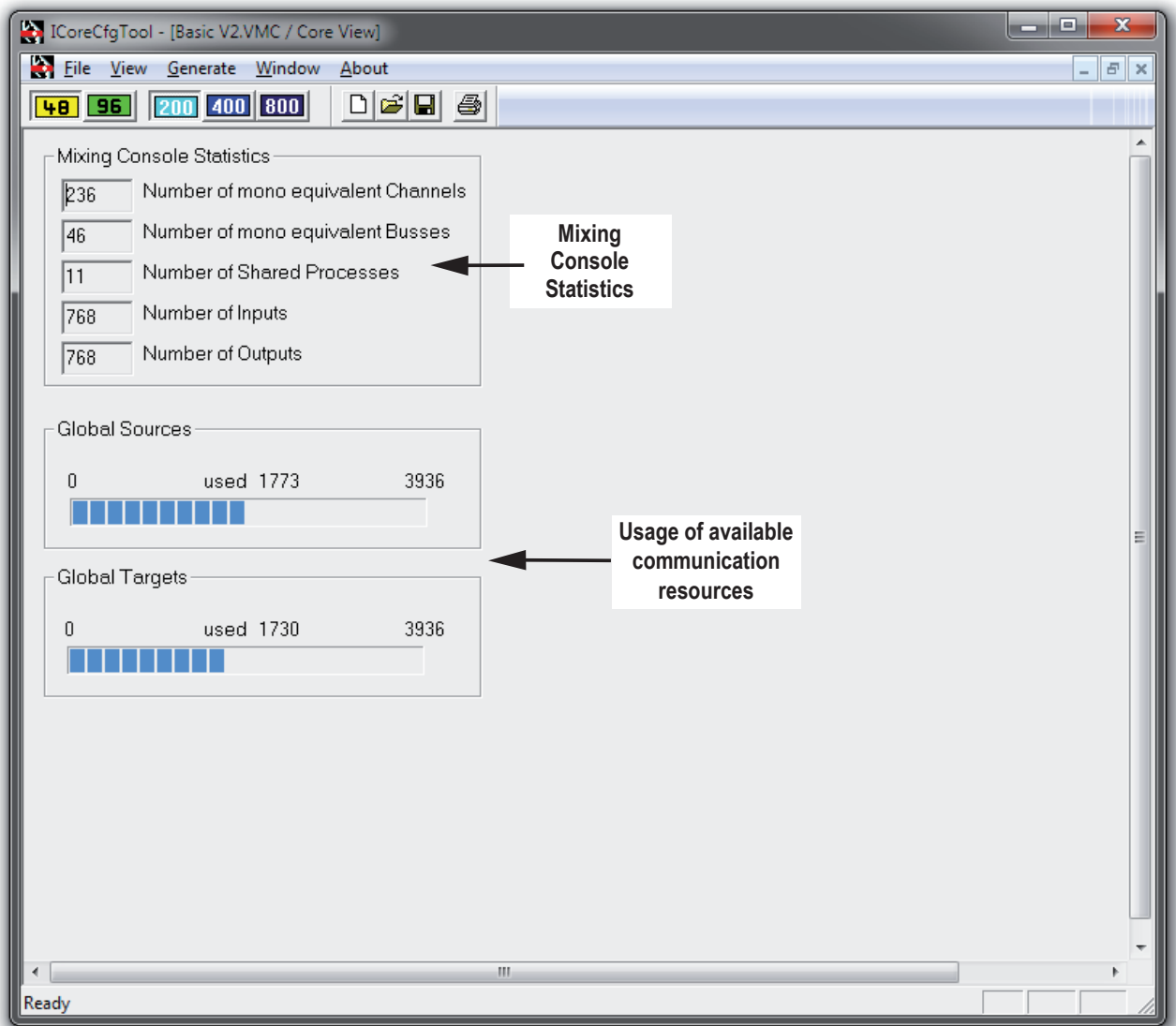

When creating a new or editing an existing configuration, the core view displays a rough estimation of the required processing resources.

When you edit a configuration and see that it requires more resources than your existing core has, there are three possibilities to continue.

Generate Core and Check Again

To find out for sure whether your edited configuration fits on the purchased Core version (Core 200, Core 400 or Core 800) , the full Generate Core process has to be done first, as will be explained in the next chapter. Once this is finished, it may happen that the requirements are less then estimated, and that your newly edited configuration could fit on the existing core version.



Tip

It is always recommended to run the Generate process before deciding whether a desired configuration will fit on a given DSP core.

Reduce the Requirements

If you do not have enough processing resources, you can either reduce your configuration slightly, by reducing the number of channels or by removing some Dynamics or EQs you do not really need, or by reducing the number of I/Os, until the configuration matches your actual core version.

Change to a different core version

The core version that you purchase with your Vista system should of course provide enough processing resources for your mixing console requirements. Should the need arise for more resources - maybe at a later time or with a major production workflow change - a core version with more resources can be ordered, which then needs to replace your current core.

6.3.3 Generate the Core File

To generate the core file for your new configuration, simply click on the 'Generate / All' menu item. This starts an automatic process which will end up with a *.xml file being saved in the same folder as the *.vmc file. A fairly complicated procedure called Load Balancing will try to compress all the required components of the new configuration into as few processing resources as possible.

You can follow what is happening on the screen. Most of the information shown on screen will also be stored into a LOG file for later viewing.

Build VMC and Processes

The Load Balancer first generates the VMC structure and then checks the channels, shared processes, buses, and builds a Core Process library.

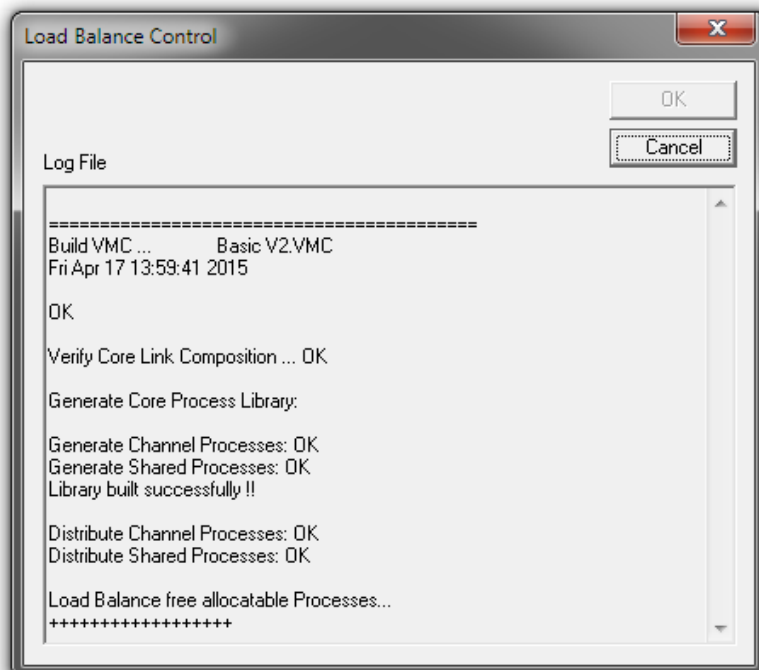

Finished ... And finally, the finished xml and Mappinginformation files are automatically stored. You only have to click OK to finish the whole process after the message 'Build All finished successfully!'.

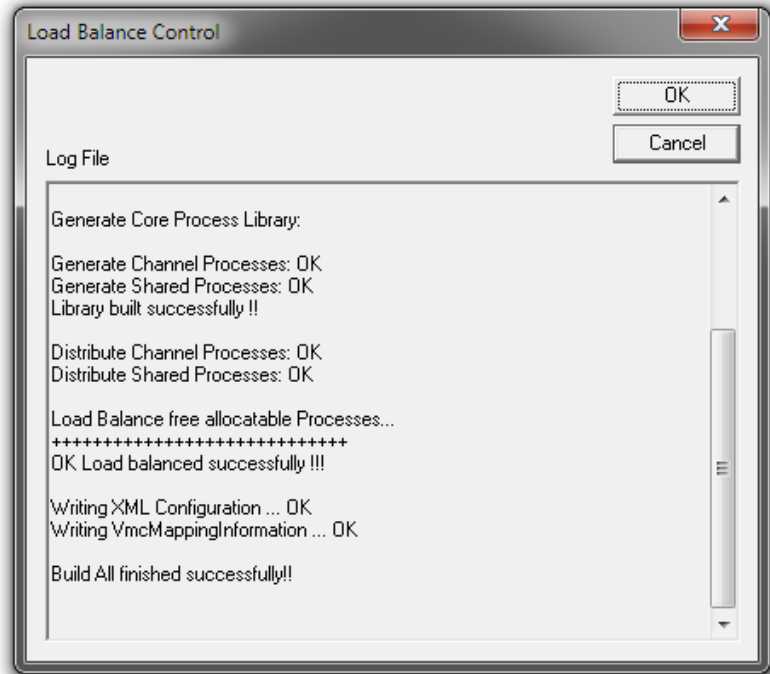

If the resources of your core are not sufficient for the generated configuration, this will be displayed with an error-message at the end of the Load Balance Control window :

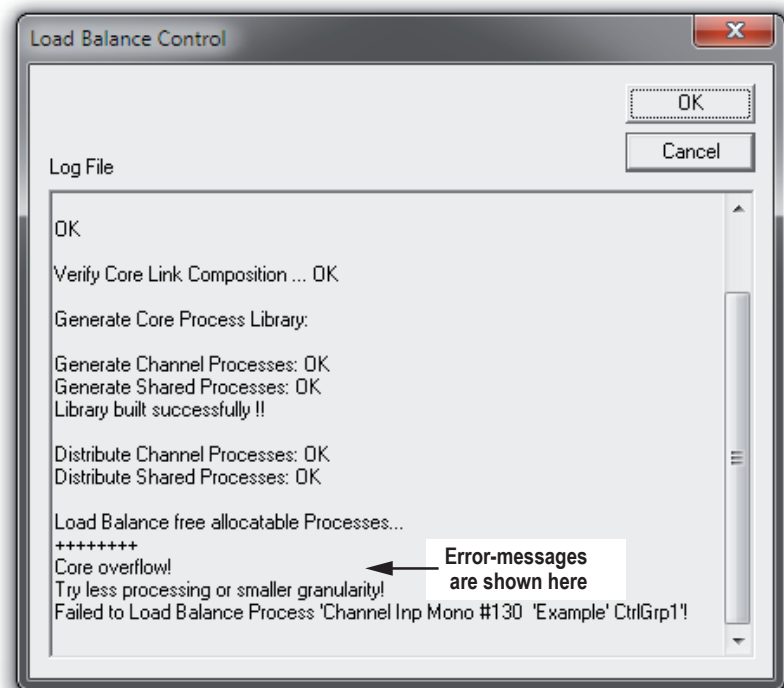

Should an error-message appear, please proceed with the instructions given in the line underneath the error-message.

6.3.4 Transfer the Files to the Console

The processing xml file and the 'meta' VMC files are now ready to be used on a Vista console.

On the Studer Vista System If you are running the Session Configuration Tool on the Vista desk, there is nothing more you need to do in order to load a configuration. Simply switch to the Vista application (i.e., the GC) and load a new configuration from the GC File menu.

On a Separate PC If you are running the Session Configuration Tool on a separate PC, you will need to transfer the configuration files to the Studer Vista control PC. Since all files are Windows files, it is a simple matter of using a transfer medium (USB stick, LAN) to transport the files. Care has to be taken to store the files under the appropriate directory on the Studer Vista control PC as described above.

The best practice is to always copy the whole folder <MyConfig> with all files inside and paste it to the C:\D950SYSTEMDB directory.

It is not necessary to copy the *.ckf file. It is not used by the Studer Vista. It is generated for maintenance reasons only.

6.4 Detailed Tutorial

The previous chapter gives a brief run through all the basics needed to configure a Studer Vista console. We recommend reading it before you proceed with the detailed tutorial, found in this chapter.

6.4.1 Set Your own Workspace

The Session Configuration Tool supports multiple windows. Up to now, a single view Window was used to operate the Configuration Tool functions. For a better overview of the configuration process, we recommend using two windows at the same time – the Channel/Bus page alternatively with the Interface page, and the Core page in addition. This allows following the rough estimation of the core requirements on-line, as you edit channels, buses and interfaces.

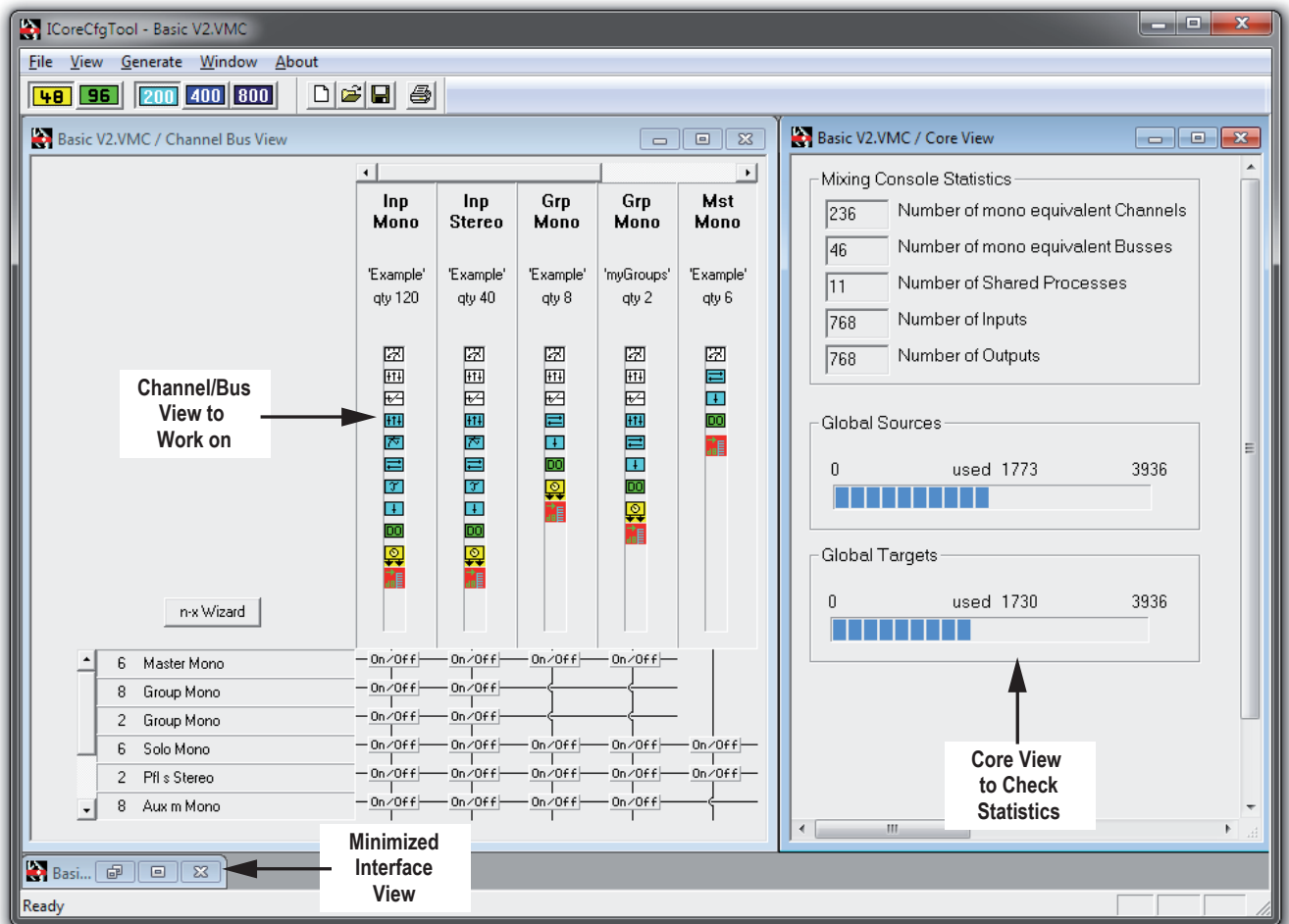

The last used Workspace setup will be stored when you close the Session Configuration Tool, and will be recalled the next time you start the program.

6.4.2 Sampling Rate

The sampling rate can be set with the two according buttons on the toolbar (48/96). It may be set anytime during configuration; however, it is wise to do it first thing when editing or generating a new configuration.

6.4.3 Channel/Bus Page

The Channel/Bus page is the main working area of the Session Configuration Tool. It allows adding new or editing existing channels, buses and their interconnections, displaying the configured console in a matrix arrangement. It displays all the configured channel types and their functions in a condensed way.

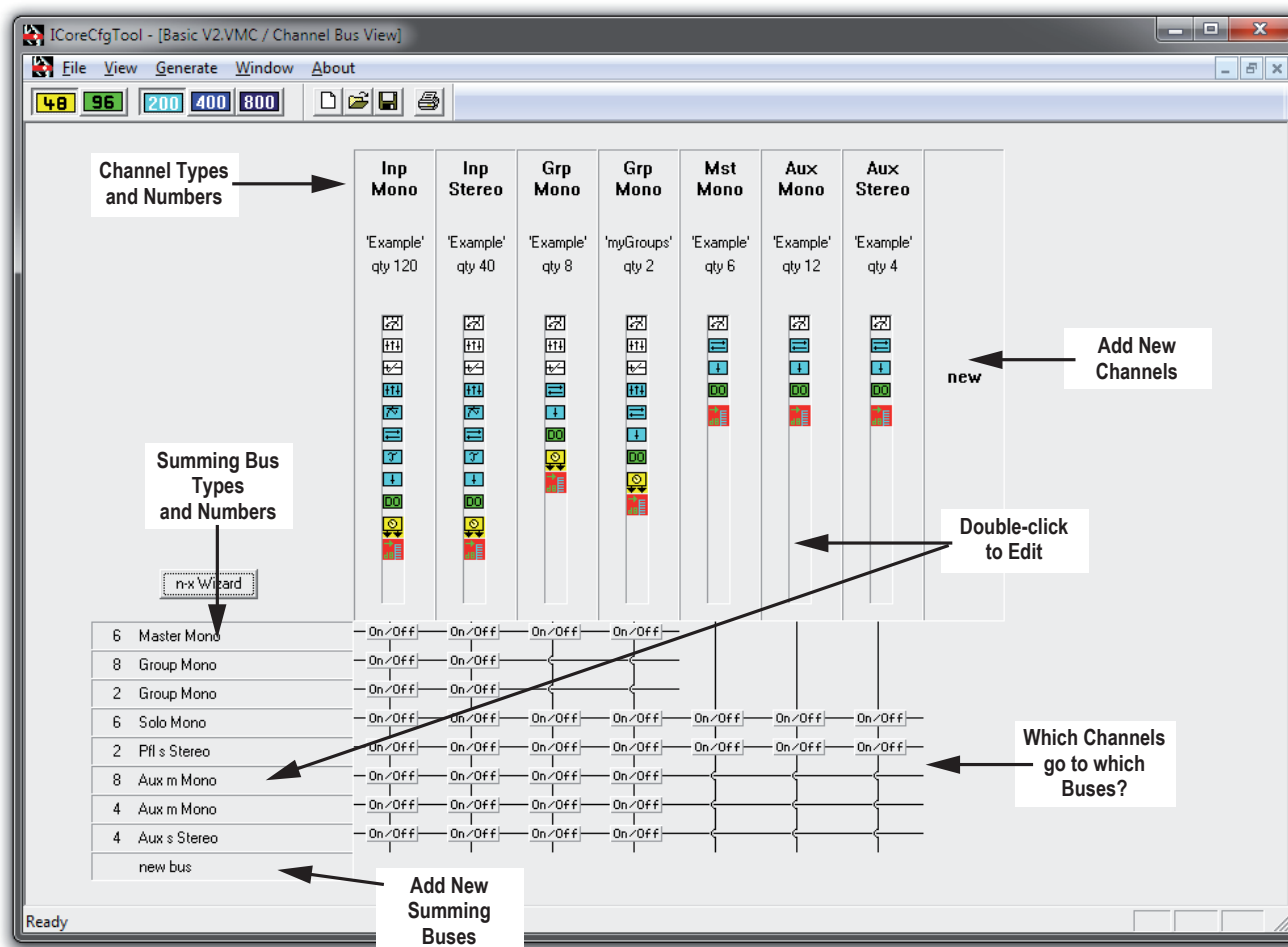

- How to:**
- Add new channels* Double-click on 'new' in the channel area
 - Add new buses* Double-click on 'new bus' in the bus area
 - Edit channels* Double-click on an existing channel type in the channel area
 - Edit buses* Double-click on an existing bus type in the bus area
 - Assign/Deassign buses* Double-click on the 'On/Off' button where the channel and bus cross. All channels of the selected type will have access to all buses of the selected type if the button is set.

6.4.3.1 Add / Edit Channels

Add New Channels
Edit Channels

Double-click on 'new' in the channel area of the Channel/Bus page.
Double-click on an existing channel type in the channel area of the Channel/Bus page.
Both actions will open the 'Add Channel' dialog box that allows editing all the entries for new or existing channels.

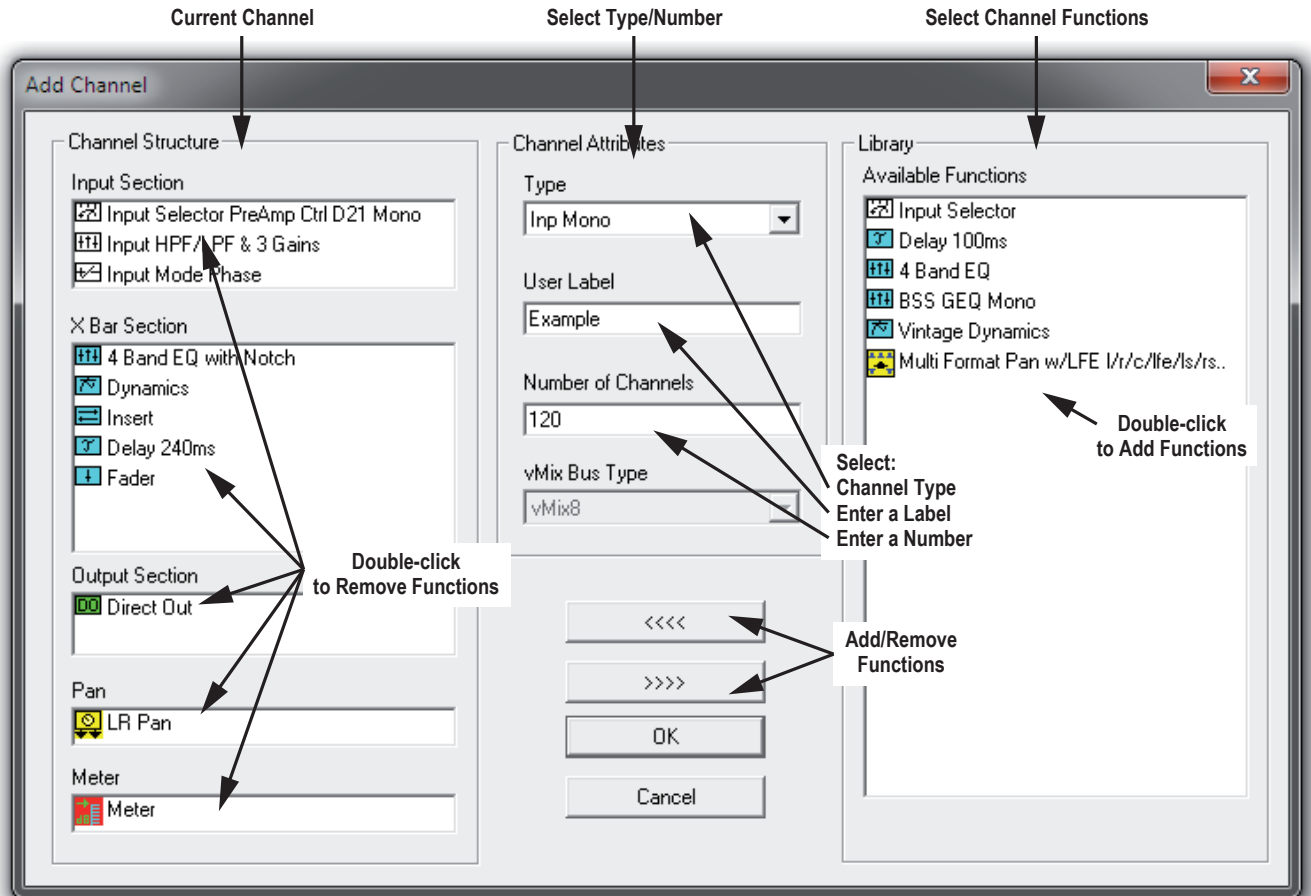

Select Channel Type

Click on the box to display the available channel types. Currently, the following channel types are available:

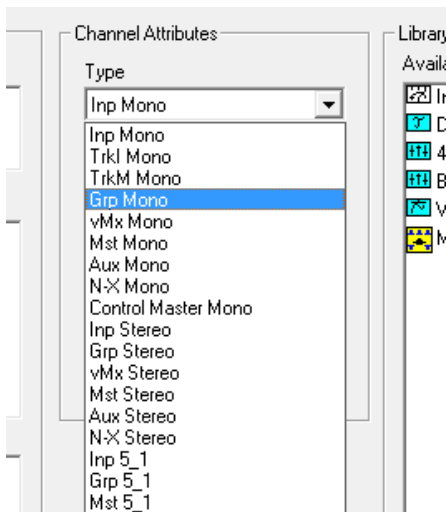

- Mono Input
- Mono Multitrack Input
- Mono Multitrack Monitor Input
- Mono Group
- VMix mono (VistaMix bus)
- Mono Master
- Mono AUX Master
- N-X mono Master
- Control Group Master (CGM is always mono)
- Stereo Input
- Stereo Group
- VMix stereo (VistaMix bus)
- Stereo Master
- Stereo AUX Master
- N-X stereo Master
- 5.1-Channel Input

- 5.1-Channel Group
- 5.1-Channel Master

All channel types correspond to similar channels of an analog console. Each channel can be assigned to a channel strip on the Studer Vista Desk upon loading of the configuration. AUX mono and stereo masters are treated as normal channels in this respect. On selection, a set of factory default functions will be loaded to the Channel Structure area, depending on channel type.

Trk I mono / Trk M mono

The Vista desk can be run in two-layer mode. These channel types largely correspond to what is known as ‘in-line’ channels. Their structure is very similar to the one of input channels; the only major difference is in the way they are both assigned to the desk. The ‘Trk M mono’ channel is always assigned to the first layer of a section, and the ‘Trk I mono’ channel to the second layer. This simulates an in-line desk layout.

Control Master

The Mono Control Master is a special channel type having any audio functions – it is the Control Group Master used for the ‘VCA’ style control groups. Up to 32 Control Masters may be configured.

User Label

User label is an optional text label that can be entered to additionally differentiate the channel types. Usually, labels are used to differentiate channels of the same type but with different functions, e.g. Input Mono ‘with EQ’, Input Mono ‘without Dynamics’, etc.

Note : These labels are only Session Configuration tool - internal. They will not be seen later when the configuration is loaded to the console.

Number of Channels

Any number can be entered here to define the quantity for this particular channel type. The maximum numbers are in function of the overall installed processing capacity (check the Core page to see how requirements change) and, for some channel types, the maximum number is limited by the capacity of the Studer Vista Desk to operate them. Desk limitations are as follows:

| | |
|----------------|--|
| Aux Mono | 40 (more then 40 Auxes can be accessed via contribution view only) |
| Aux Stereo | 40 (more then 40 Auxes can be accessed via contribution view only) |
| Control Master | 32 |

Current Channel Structure

This area displays the functions that have been selected for the current channel type. There are five sections of each channel, corresponding to the audio signal flow:

- Input Section
- X-bar Section (order of functions can be set in the Vista GC using drag-and-drop)
- Output Section
- Pan Section
- Meter Section

The functions have icons in different colours corresponding to each of the five sections above. Functions can be removed from the current channel by double-clicking on the function, or by using the >>>> button. Each of the functions requires processing power, therefore it is prudent to keep only the functions that are really needed. The minimum functions of a channel are:

- Input Selector (cannot be removed but replaced by one of the two remaining Input Selectors)
- Fader (cannot be removed)
- Direct Out.

Library / Available Functions In this area, the functions available from the system library are listed. The list changes slightly depending on the channel type (e.g. master channels do not have a Pan function available), but most functions are the same for all channel types. This means that master channels may be configured with an EQ, or an Aux master can have a limiter if needed. Functions can be added to the current channel by double-clicking on the function in the library, or by using the <<<< button.

Please note that several restrictions to the X-bar section apply:

- The X-bar section can contain a maximum of 6 functions.
- ‘Delay 100 ms’ and ‘Delay 240 ms’ must not be used at the same time.
- ‘4-Band EQ’ and ‘4-Band EQ Notch’ must not be used at the same time. However, one of the two four-band EQs and the graphic EQ may be used together.
- Standard and Vintage Dynamics cannot be used at the same time.

Remove Channels Simply click on the channel type to be removed and hit the ‘Del’ (delete) key.
Tip Note how the requirements shown in the ‘Core Statistics’ area in the Core page change as you add or remove channels, change their number, or add/remove functions.

6.4.3.2 Function Library

Functions Common for Mono and Stereo Channels:

| | |
|-----------------------------------|--|
| Input Selector | 3-way input selector, or |
| Input Selector PreAmp Ctrl | 3-way input selector, with a control interface for D19m or D21m pre-amplifiers. |
| Input HPF/LPF & Gain | Variable high-pass and low-pass filters, channel gain ± 24 dB. |
| Insert | Insert function with dry/wet mix feature. |
| Delay 100 ms | Variable audio delay 0...100 ms. |
| Delay 240 ms | Variable audio delay 0...240 ms. |
| 4-Band EQ | Fully parametric 4-Band EQ with Bell/Shelving switch in the LO and HI bands, Constant Q/Constant Range switch in the HI-MID and LO-MID bands. |
| 4-Band EQ Notch | Fully parametric 4-Band EQ with Bell/Shelving switch in the LO and HI bands, Constant Q/Constant Range switch in the HI-MID and LO-MID bands, with additional Notch filter. |
| Graphic EQ | BSS® 30-band graphic equalizer. |
| (Standard) Dynamics | Full dynamics section with Compressor, Limiter, Expander, Gate, Lookforward circuit and Auto Make-up gain, Sidechain with HP/LP Filter. |
| Vintage Dynamics | While the standard Vista dynamics algorithms have been described as rather ‘transparent’, a different dynamics section has been created where in particular the compressor is utilized in a more pronounced way, i.e., as an effect itself. This compressor unit is targeted to be flexible enough for many different types of sound coloration, including extreme and unusual settings. |
| Direct Out | Direct Channel Output. |
| Meter | Level meter function, switchable to channel input or after fader. |
| LR Pan | Standard Left/Right amplitude panner. |

Functions for Mono Channels Only: *(VSP currently not available for Infinity Core)*

| | |
|------------------------------|--|
| Input Mode Phase | Phase reversal switch. |
| Multiformat Pan w/LFE | Format selection: 2CH, LCR, LCRS, 5.1, EX, 7.1, Amplitude Panning, adjustable Divergence and center usage, Panaround feature, and LFE feed. |
| VSP | VSP (Virtual Surround Panning): Format selection: 2CH, LCR, LCRS, 5.1, EX, 7.1, Amplitude Panning, adjustable Divergence, Panaround feature, |

Intensity, Frequency-depending and echo Pan modes, Simulation algorithms for several surround microphone types (HRTF, ORTF, AB, Sphere), Simulation of Virtual Rooms with Room Size Control, Ambiance & Absorption Controls, Variable Source Distance.

Functions for Stereo Channels Only:

| | |
|--------------------------------|--|
| Input MS Mode Bal Phase | MS/XY decoding matrix, stereo mode (Normal, LL, LR, Reverse, Mono), input balance and phase switch L, R, LR. |
| Dir | Stereo direction control. |
| Dir Width | Stereo direction with stereo width control 0...200%. |
| Upmix | Upmix panner for insertion of a stereo signal into a surround mix. |
| Meter Correlation | Level meter function, switchable to channel input or after fader, with additional correlation display for optimum mono compatibility of stereo signal. |

Functions for 5.1 Surround Channels:

| | |
|-----------------------------------|---|
| Input Selector PreAmp Ctrl | 3-way input selector, with a control interface for pre-amplifiers (D21m only). |
| Input HPF/LPF & Gain | Variable high-pass and low-pass filters, channel gain ± 24 dB. |
| Input Mode Pan 5.1 | For positioning a 5.1-channel surround signal into a surround mix. |
| Delay 700 ms | Variable audio delay 0...700 ms. |
| 4-Band EQ Notch | Fully parametric 4-Band EQ with Bell/Shelving switch in the LO and HI bands, Constant Q/Constant Range switch in the HI-MID and LO-MID bands, with additional Notch filter. |
| (Standard) Dynamics | Full dynamics section with Compressor, Limiter, Expander, Gate, Lookforward circuit and Auto Make-up gain, Sidechain with HP/LP Filter. |
| Direct Out | Direct Channel Output |
| Meter | Level meter function, switchable to channel input or after fader. |

6.4.3.3 Add / Edit Buses

| | |
|------------------------------|---|
| Add New Buses | Double-click on 'new bus' in the bus area |
| Edit Buses | Double-click on an existing bus type in the bus area |
| Assign/Deassign Buses | Double-click on the 'On/Off' button, where the corresponding channel and the bus are crossing. All channels of the selected type will have access to all buses of the selected type if the button is set. |

Both the Add and the Edit actions will open the 'Edit Bus' dialog box that allows editing all the entries for new or existing buses.

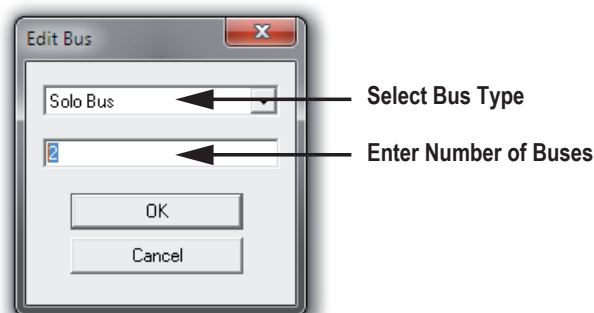

Select Bus Type Click on the box to display the available bus types. Currently, the following bus types are available:

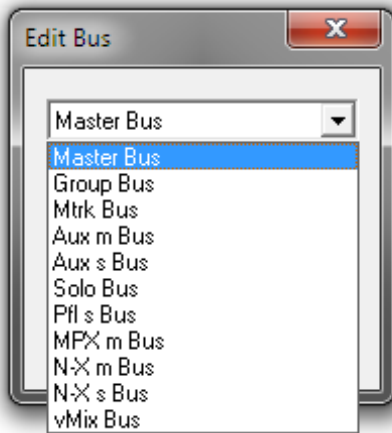

- Mono Master bus
- Mono Group bus
- Mono Multitrack bus
- Mono AUX bus
- Stereo AUX bus
- Mono SOLO bus
- Stereo PFL bus
- Mono MPX bus
- Mono N-X bus
- Stereo N-X bus
- VMix bus

Number of Buses

Any number can be entered here to define the quantity for this particular bus type. The maximum numbers are in function of the overall installed processing capacity (check the Core page to see how requirements change). Desk limitations are as follows:

Total number of buses

If greater than 120, the global bus assign view will only display the first 120. In the local bus assign view, there is no limitation.

Bus Conventions

There are three types of stereo buses:

- Aux Stereo bus
- PFL Stereo bus
- N-X Stereo bus

These bus types have to be entered bearing in mind that their number is counted as stereo. All other bus types are mono, regardless how they are used. For example, having eight mono master channels and eight stereo master channels will need a total of 24 mono master buses.

The required numbers are automatically entered into the Edit Bus dialog based on the number of corresponding channels. In the example above, the Edit Bus box will suggest 24 buses automatically.

For buses which do not correspond to channels (Multitrack, SOLO and PFL), the suggested number will be initially zero and must be set by hand.

☞ Important Tips

When having mono, stereo and 5.1 channels of the same type (applies for master and group channels only), you have to make a packet of buses for each type. The **first** packet will be connected to the **5.1** channels, the **second** packet to the **stereo** channels and the **third** packet to the **mono** channels.

If all channels (mono, stereo and 5.1) are defined before any of the buses are created, the total number of necessary buses is suggested, and the building of the channel-specific packets is done automatically!

Otherwise it has to be paid attention that the given sequence of bus packets is obeyed :

- **First** packet of buses corresponds to **5.1** channels
- **Second** packet of buses corresponds to **stereo** channels
- **Third** packet of buses corresponds to **mono** channels

The screenshot on the next page explains in better detail :

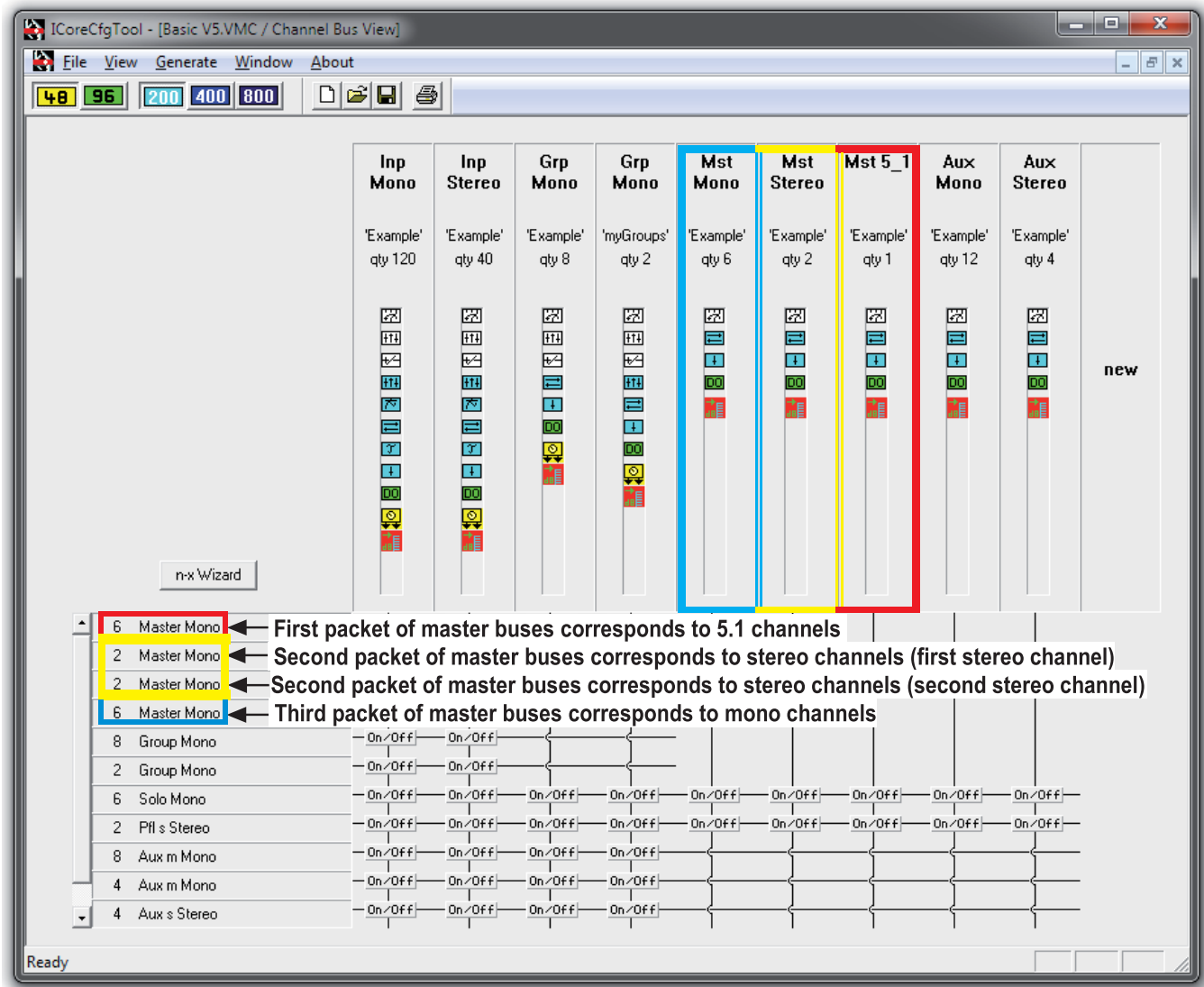

Tip When changing the bus structure (applies for master and group channels only) in an existing configuration, first delete the corresponding buses (group or master) before adding the new buses, in order to guarantee the correct bus sequence.

PFL and Solo buses Typically, there will only be one stereo PFL bus. The number of Solo buses has to comply with the surround format – i.e., for the 5.1 format you will need six Solo buses.

More buses than channels It is legal to have more buses than corresponding channel types. The reason for this is that the buses (unlike in analog consoles) are valid audio signals and can be used as such in the Studer Vista patch. They are simply summing buses which will output the sum of all assigned inputs, which means that the buses can also be used as components of multiformat stems.

Packets of eight Please note that when creating a large number of a certain bus type, always multiple packets of eight such buses are created. The packet-size of eight is the largest possible bus packet. So when adding 52 multitrack buses, you will get six packets of eight buses, plus one packet of 4 buses.

Remove Buses Simply click on the bus type to be removed and click the ‘Del’ (delete) key.

6.4.3.4 Special Configuration Function: Stems

The Stems concept is unique to the Studer Vista.

For Film style mixing, bits and pieces of film sound are put together from a variety of surround formats, ranging from mono to eight channels. Very often, there may be hundreds of audio sources that need to be mixed together and put into the right spatial image. In order to bring some order to such a vast number of sources and formats, a concept of Stems is often used.

A Stem is a group of sounds (i.e., audio summing buses) that belong together. Stems can be 1-channel to 8-channel wide.

For example, a console may be configured to have: 2 × Stereo stems for music, 3 × LCR stems for simple effects, 1 × 5.1 stem for effects, 1 × Stereo stem for dialog etc., 1 × 8-CH stem for effects, 2 × Dolby Surround (4-CH) stems for predubs.

The basic Stem setup is defined in the Session Configuration – the number, type and assignment of Stem buses is fixed. In the Studer Vista GC, there are controls for dynamic Stem setup and for assignments of the related recorder tracks. In this way, the Stem setup may be changed dynamically as the need arises. The restriction to the total number of Stems is the number of buses for a certain Session Configuration. Studer Vista Master, Mono Group and/or Track buses are used to build a system of Stems (each stem consists of a number of buses) up to a maximum of 104 Stem buses at any time.

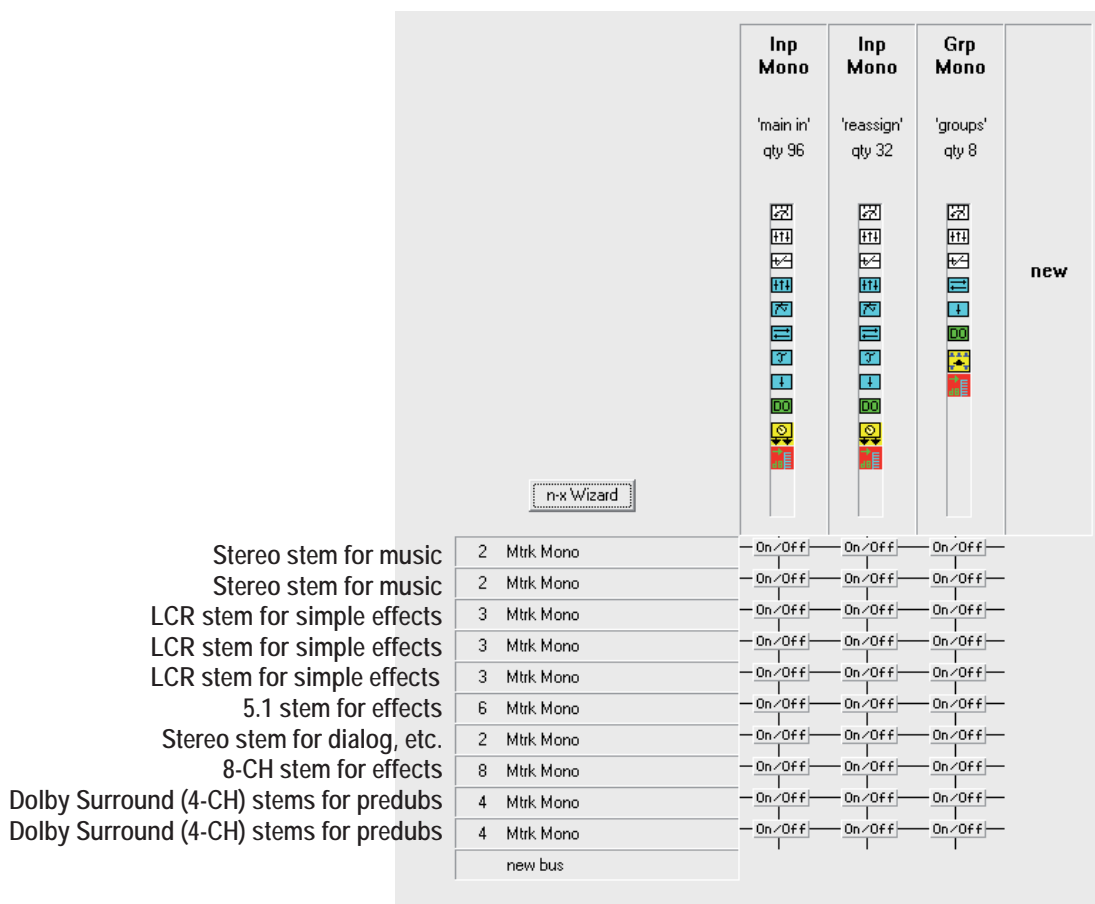

In this example, the bus structure has been set to allow for the above stem configuration using multitrack buses as Stem buses. A total of 37 multitrack buses has been configured by adding new buses for a stem of 2, a stem of 2, a stem of 3, etc. All 136 input and group channels have access to all ten stems.

6.4.4 Interface Page

The interface page allows viewing and editing of the audio interfacing to the DSP core. It is important to assign enough audio input and output interfaces so that the configured system can work satisfactorily. Two interface types can be edited here:

- A-Link In
- A-Link Out

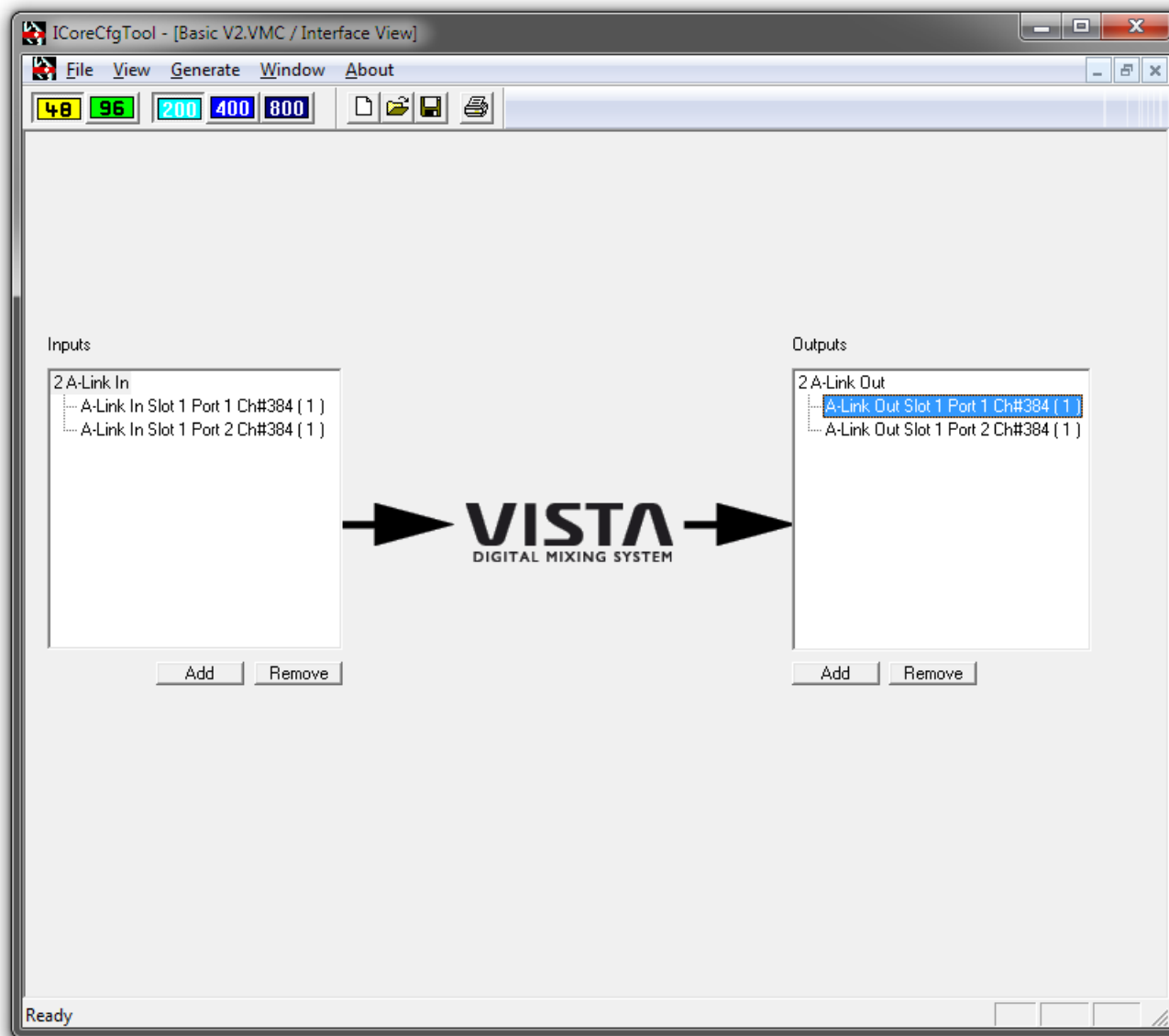

Edit A-Link ports To add A-Link input interfaces to the system configuration, simply click on the 'Add' button in the Inputs area and a dialog box will appear:

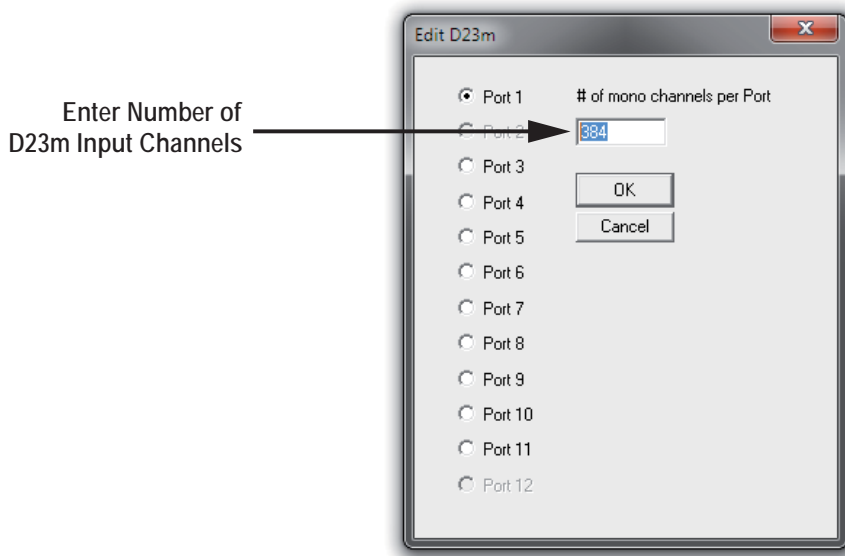

The number of channels per each A-Link port has to be entered, and the process must be repeated for every A-Link port. The number of channels must be a multiple of eight which is the smallest function unit.

After adding the required interfacing, the display will show all configured A-Link ports, starting with port number 1.

To remove unused A-Link ports from the system configuration, simply select the port to be removed (or to remove all, select the uppermost line) and click on the Remove button, or use the 'Del' (delete) key.

6.4.5 Core Page

The Core page displays the statistics of the channels, buses, and I/Os, as well as the usage of the available communication resources.

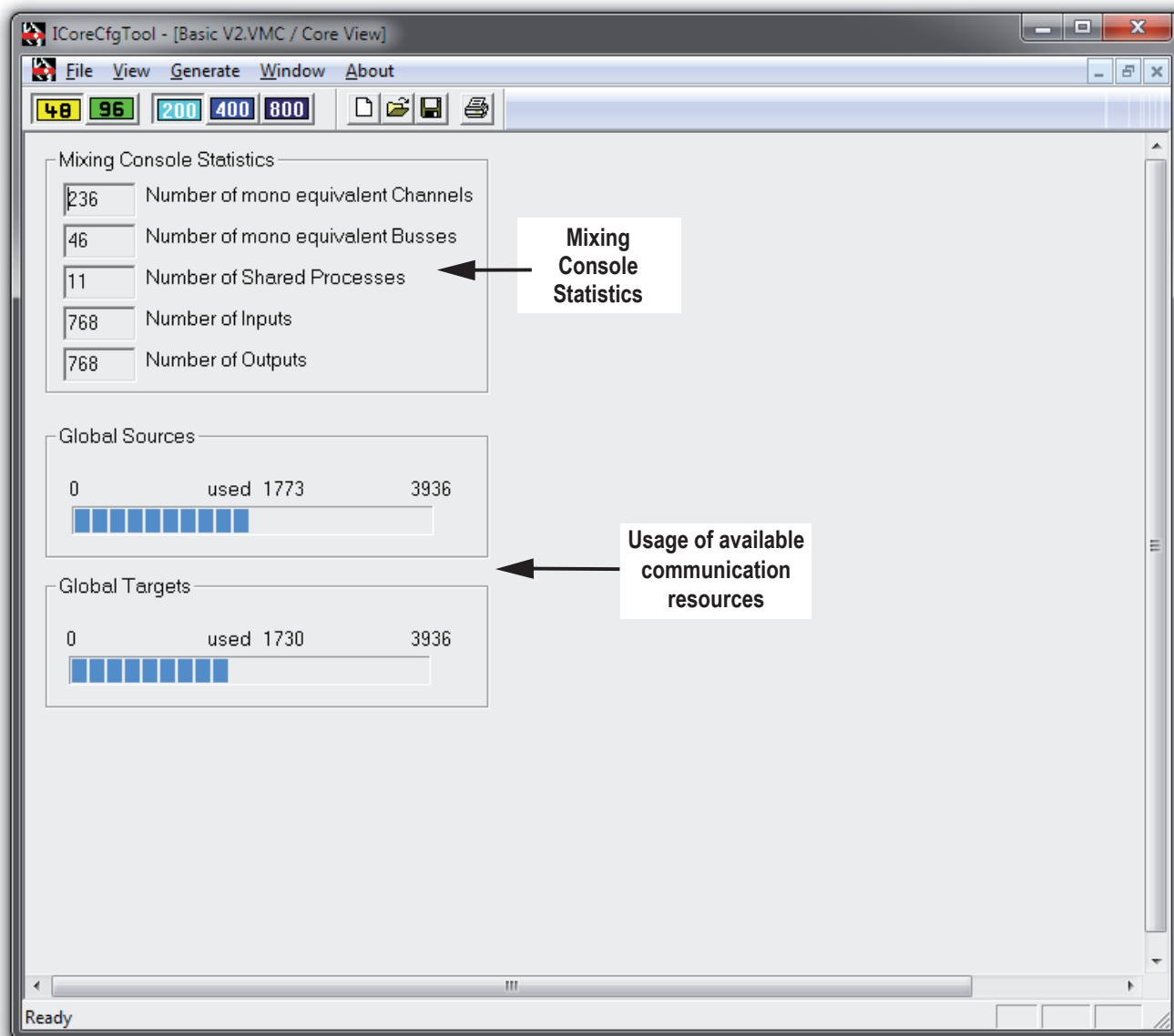

Mixing Console Statistics This area indicates the configured number of channels, buses, shared processes (test tone generator, side-chain links), and input and output interfaces. These numbers reflect all the entries that have been made during the configuration process.

Global Sources/Targets usage Shows the currently used communication resources.

6.4.6 Shared Functions Page

The Shared Functions page allows adding and editing the shared functions. Currently the following shared functions are available:

- Generator
- Dynamics sidechain link
- Downmix (surround to stereo)
- Monitor stereo (monitoring DSP)
- Monitor multi-format (monitoring DSP)
- Stereo-to-mono
- Delay 240 ms
- Delay 10 s
- Dynamic EQ

Generator The Generator is used to test the console with sine-wave, white noise, and pink noise signals. The number is automatically set to 1.

Dynamics Sidechain Link The dynamics sidechain link allows to link the controls (sidechains) of the dynamics sections of up to eight different channels. It is similar to the ‘stereo link’ function found on many standalone compressor/limiters, but the number of linkable channels has been set to eight rather than only two, so that all current surround formats can be supported. The dynamics sidechain link requires processing power, so the number is best set to the required minimum. The default number is zero, and the number can be set freely.

Other Functions Audio functions have the same functionality as their corresponding channel functions.

Core Version In addition to the processing functions described above, also the core version of the Infinity Core is specified in the shared functions page. This entry must correspond with the hardware version of your Infinity Core.

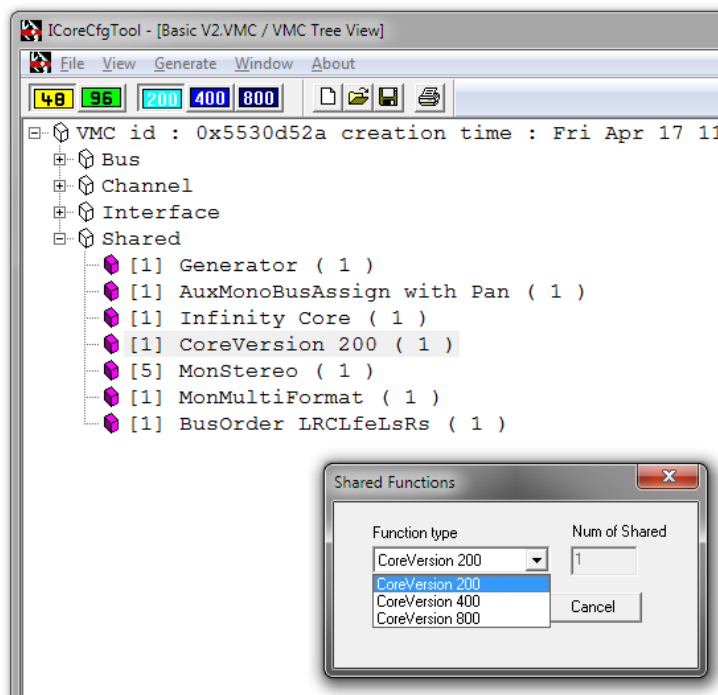

Edit shared functions To edit the numbers of shared functions go to the VMC Tree View. Or right-click to one of the entries.

6.4.7 Session Configuration Toolbar and Menus

Most of the functions of the Session Configuration Tool are controlled directly from the four View pages as described in the previous chapters. There are, nevertheless, some functions that are accessible only via the menus. The following descriptions briefly explain all the menu items, and only go into details for functions not explained in the previous chapters.

6.4.7.1 Toolbar



- 48** Set sampling rate to 48 kHz.
- 96** Set sampling rate to 96 kHz.
- 200** Set the core version to 'Core 200'
- 400** Set the core version to 'Core 400'
- 800** Set the core version to 'Core 800'

6.4.7.2 File Menu

- New** Opens a new, empty configuration file called 'Untitled'.
- Open** Opens an existing *.vmc configuration file. Looks into the folder C:\D950SYSTEMDB.
- Close** Closes the current *.vmc configuration file.
- Save VMC** Saves the current *.vmc configuration file under the same name, thus overwriting it.
- Save VMC As...** Saves the current *.vmc configuration file under a different name. The extension *.vmc does not have to be typed out. Generates a new folder with the same name as the *.vmc configuration file and saves the *.vmc configuration file there.
- Save VMC Overview** Saves the Overview of the current *.vmc configuration file as a *.txt file. The overview contains condensed information on the current configuration.
- Print VMC Overview** Prints the Overview of the current *.vmc configuration file. The overview contains condensed information on the current configuration.
- Print Preview** Shows the Overview of the current *.vmc configuration file on screen.
- Print Setup** Standard Windows printer setup.
- Exit** Quits the Session Configuration Tool.

6.4.7.3 View Menu

- Vmc** Currently has no function.
- FuncLib** Currently has no function.
- Log File** Shows the Log File that contains information on the last several Generate runs. The oldest information is shown at the top of the file.
- Tool Bar, Status Bar** Switches the Tool Bar and The Status Bar on and off.
- Channel Bus** Brings up the Channel Bus page. For a description, please see previous chapters.
- Interface** Brings up the Interface page. For a description, please see previous chapters.
- Shared and External** Brings up the VMC Tree View (see [chapter 6.4.7.4](#)).
- Core** Brings up the Core page. For a description, please see previous chapters.
- Tree** Brings up the VMC Tree View (see [chapter 6.4.7.4](#)).

6.4.7.4 VMC Tree View

The VMC Tree View can be used to view and even edit the configuration.

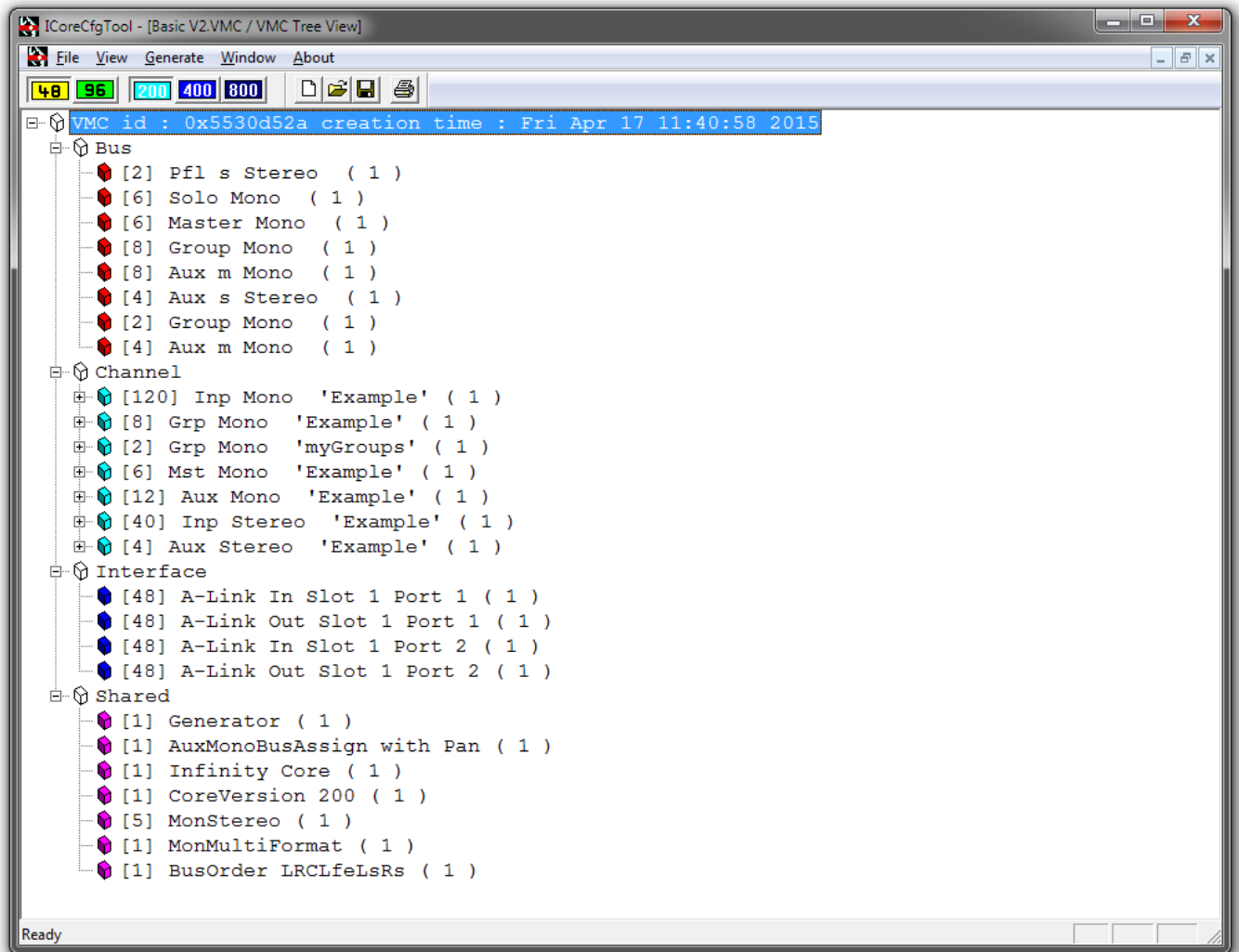

- Edit an Item** Right-click on any function and choose 'Edit' from the dropdown menu.
- Delete an Item** Right-click on any function and choose 'Delete' from the dropdown menu.
- Delete all Buses** Right-click on the 'Bus' item and choose 'Delete' from the dropdown menu.
- Delete all Channels** Right-click on the 'Channel' item and choose 'Delete' from the dropdown menu.
- Delete all Interfaces** Right-click on the 'Interface' item and choose 'Delete' from the dropdown menu.
- Delete All Shared Functions** Right-click on the 'Shared' item and choose 'Delete' from the dropdown menu.
- Add New Items** Right-click on the root item ('VMC id :...'), choose 'Add' from the dropdown menu, and select the desired item.
- Add Shared Functions** Right-click on the root item ('VMC id :...'), choose 'Add' from the dropdown menu, and select 'Shared'. The following dialog will appear:

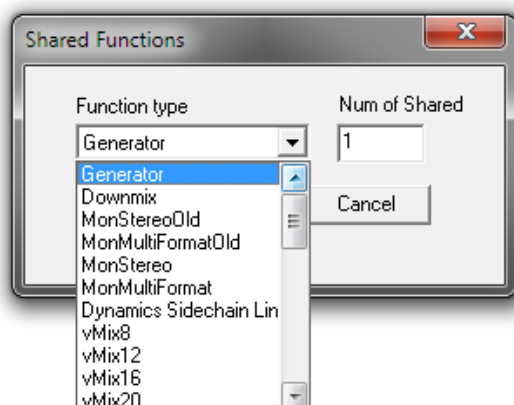

- Important** The number of functions is set to 1 per default. Enter the desired number of functions here.

6.4.7.5 Generate Menu

- All** Starts the Load Balancing and automatic generation of the processing xml file. For a description, please see previous chapters.

6.4.7.6 Window Menu

This menu contains standard functions for windows management. Multiple windows and copies of existing windows are allowed.

- New Channel Bus** Opens a new Channel Bus page, or, if there are already Channel Bus pages, creates a new copy of the page.
- New Interface** Opens a new Interface page, or, if there are already Interface pages, creates a new copy of the page.
- New Core** Opens a new Core page, or, if there are already Core pages, creates a new copy of the page.
- New Tree** Opens a new VMC Tree dialog.
- Cascade** Arranges the Workspace as cascaded windows.
- Tile** Arranges the Workspace as tiled windows.
- 1, 2, 3, ...** Brings the selected page to the top of the workspace

6.5 Maintenance

6.5.1 Managing the Files – Which File is Where?

Any Session Configuration starts with five files:

- the ‘meta’ VMC file called `MyConfig.vmc`
- the processing xml file called `MyConfig.xml`
- the MixercloudPaths file called `MyConfig-MixercloudPaths.txt`
- the VmcMappingInformation file called `MyConfig-VmcMappingInformation.xml`
- the configuration knowledge file called `MyConfig.ckf`

They are stored in a subfolder (with the name of the configuration) of the Session Configuration folders on the Studer Vista PC.

6.5.2 CoreCfgTool.ini

The `C:\CoreCfgTool` directory contains the `CoreCfgTool.ini` file. This file tells the Configuration Tool where to look for various components and what the basic settings are.

The Session Configuration Tool for the Infinity Core actually is the very same Session Configuration Tool as used for the SCoreLive (starting from SW 5.2.00). Whether it is used for the SCoreLive or for the Infinity Core is decided by the `CoreCfgTool.ini` file.

There are two templates of the .ini files in the folder `C:\CoreCfgTool`:

- `CoreCfgTool.sCore`
- `CoreCfgTool.ini`

CoreCfgTool.sCore è

This file must be renamed to .ini when used with SCoreLive systems.

CoreCfgTool.ini è

This file is ready to be used with the Infinity Core systems.

To doublecheck whether the correct version of the file is active, the file can be opened with a text editor and the entry ‘`CoreType=` ’ can be verified.

6.5.2.1 Content of the Core Knowledge File

The Core Knowledge file offers the following information on a Configuration.

| | |
|------------------------|--|
| VMC ID | Identification of the VMC used to ensure that the <code>*.vmc</code> and <code>*.xml</code> files match. |
| Sampling Rate | 48 kHz or 96 kHz |
| Tasks | Shows the task (channels, buses....) of the configuration. |
| CoreCfgTool.ini | A copy of the <code>*.ini</code> file used to generate the configuration. |

6.5.3 Troubleshooting

The Session Configuration Tool was checked at the factory during more than a year for malfunctions and erroneous operations. Hundreds of different configurations were tried, and all sorts of tests have been made. Nevertheless, since there exists an almost infinite number of channel, bus, and I/O configuration combinations, not all of them could be tested. So it may happen that on a very rare occasion an error message will be issued during editing or during the Generate process. A description of some of the typical error messages is listed below.

6.5.3.1 Errors and Warnings During Generate Process / In Log File

When Inserting a New Function When inserting a new function that exceeds the capacity of the core, the following dialog will appear:

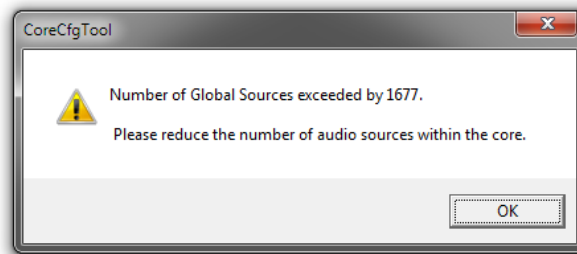

This message is very likely to appear when the console is operating with 96 kHz, or when switching from 48 to 96 kHz. If you decide to proceed in generating the configuration regardless of the warning, a message will be displayed in the Generate All dialog, and the configuration process will be stopped.

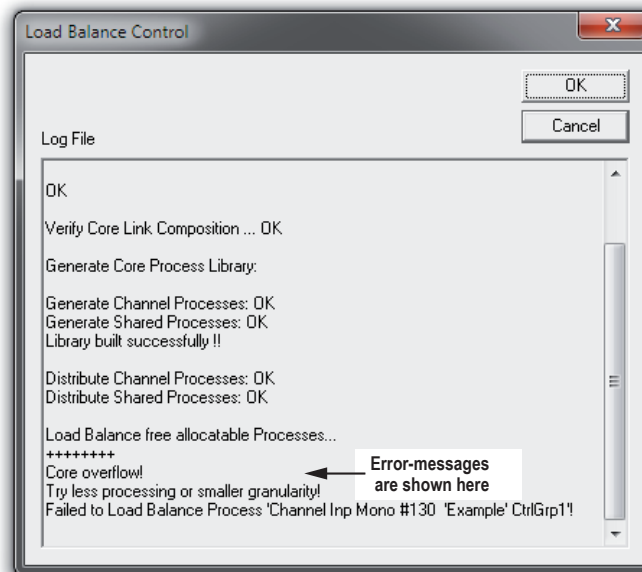

Should an error-message appear, please proceed with the instructions given in the line underneath the error-message.

CHAPTER 7

| | | |
|----------|-------------------------------------|----------|
| 7 | DAW Control | 2 |
| 7.1 | Basics | 2 |
| 7.2 | Vista Settings | 5 |
| 7.3 | DAW Settings | 7 |
| 7.4 | Connect the Sessions | 8 |
| 7.5 | Control Keys in Channel Strip | 10 |

7 DAW CONTROL

7.1 Basics

With the Vista consoles it is possible to directly operate Digital Audio Workstations (DAW) from the desk surface. This is realized by using two different serial communication protocols: The more straightforward and simpler 'Mackie Control Protocol' and the more complex 'Mackie HUI Protocol'. A choice of the most popular DAWs is supported and has been tested with the Vista desk control:

- Digidesign ProTools (Mackie HUI protocol)
- Apple Logic Pro (Mackie control protocol)
- Merging Technologies Pyramix (Mackie HUI protocol; *Mackie control protocol not fully supported*)
- Steinberg Cubase / Steinberg Nuendo (Mackie control protocol; *Mackie HUI protocol: only 8 channels supported*)
- Magix Samplitude / Sequoia (Mackie HUI protocol, Mackie control protocol)
- SADiE (*Mackie HUI protocol: only 8 channels supported; Mackie control protocol: only 24 channels supported*).

Thanks to an extended strip setup, so-called DAW channels can be inserted into any desired slot of the setup. With a DAW channel a number of DAW controls can be operated, as provided by the Mackie Control protocol: The fader level as well as the status of mute, solo and track arming. The transport control keys on the desk can be used for transport commands to the DAW.

Transport control keys are optional on the desk of the larger Vista versions only; on any Vista console, however, the transport controls are available in the TC/Generator window; they can also be used for transport commands to the DAW.

The TC/Generator window is opened by a click on the Ribbon Tools Tab icon shown left.

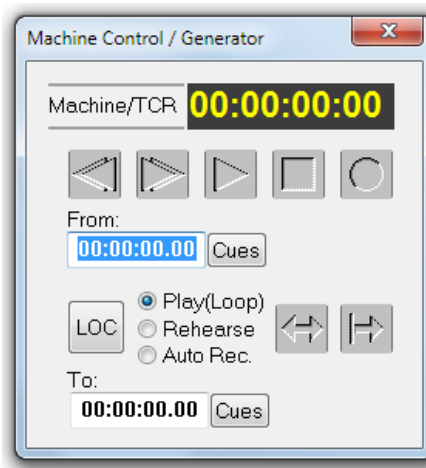

Note *DAW channels are excepted from snapshots and presets, no DAW settings will be saved or can be recalled, apart from the channel strip position defined in the strip setup. In addition, DAW channels cannot be automated by the dynamic automation; however, this can be made on the DAW itself in an elegant way.*

When controlling the DAW via HUI, an auto-label mechanism copies the channel labels of the workstation project to the DAW channel strip on the Vista console. If the DAW should not support HUI (see list above), user labels can be entered in the strip setup now for every DAW channel.

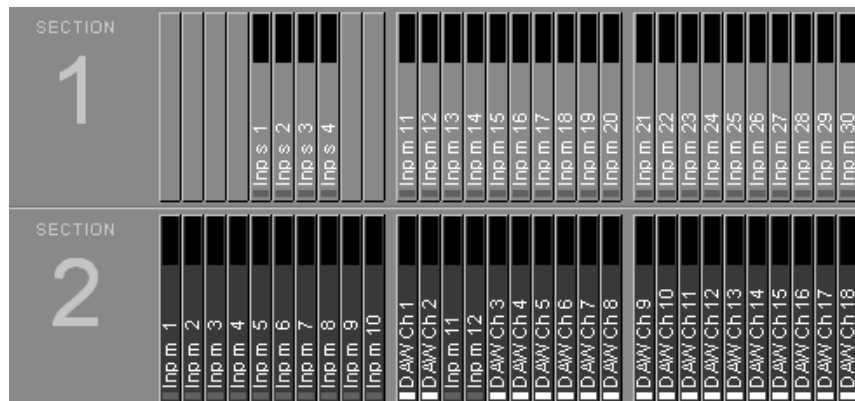

| EMPTY | DEL |
|------------------------|---------------|
| Input | ▶ |
| Group Master | ▶ |
| Master | ▶ |
| Aux Master | ▶ |
| Control Group Master | ▶ |
| DAW Control | ▶ |
| VMix | ▶ |
| Cut | Ctrl+X |
| Copy | Ctrl+C |
| Paste | Ctrl+V |
| Edit User Label | Ctrl+E |

Note Only *one* DAW can be controlled at a time. The Mackie protocols support *a maximum of 32 channels*, so this is also the maximum number of DAW channels that can be controlled.

Protocol selection (Mackie Control or Mackie HUI) is done in the Vista Settings dialog. This is not done automatically but has to be decided by the user:

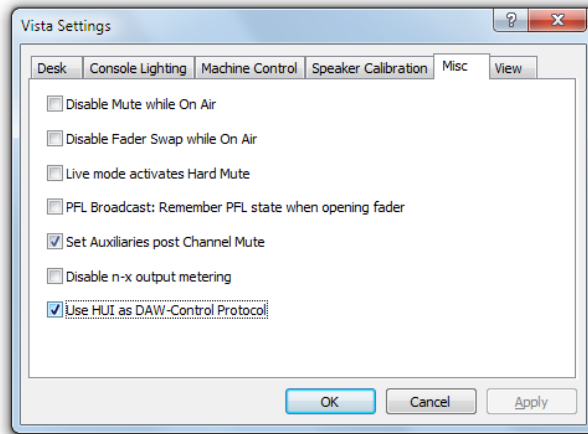

To enable transport control specifically for the connected DAW, there is a new menu option in the TC Reader / Generator setup dialog. Please note that the 9-pin serial control is disabled as soon as the DAW Control setting is selected:

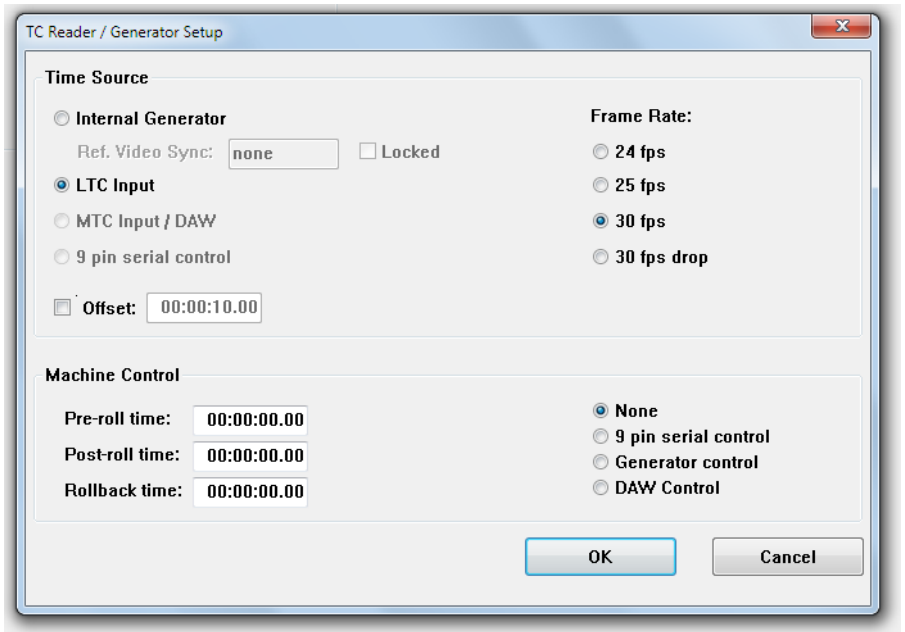

MIDI-Over-Ethernet

Instead of the MIDI connection normally used as the physical layer for the Mackie protocols, a MIDI-over-Ethernet solution is applied that allows using one single Ethernet Cat5 cable instead of several MIDI cables. Therefore the 'rtpMIDI' driver needs to be installed on both the Vista desk PC and on the DAW.

7.2 Vista Settings

rtpMIDI (rtpMIDI is the current MIDI-over-Ethernet driver, that needs to be installed on the Vista console PC)

- Install rtpMIDI v1.1.4.235 (requires Bonjour V2.0.2.0 or later) - for installation details, please refer to the Vista Installation Note “Vista DAW Control with rtpMIDI”

Setup of rtpMIDI on Vista Run rtpMIDI and create 4 Sessions using the [+] -Button. The sessions will automatically get the name of the computer and will appear in the directory window. Rename the sessions to Vista, Vista (1), Vista (2), Vista(3) as shown below.
Enable the sessions with the checkmark in the order below - start with “Vista”, then “Vista (1)”

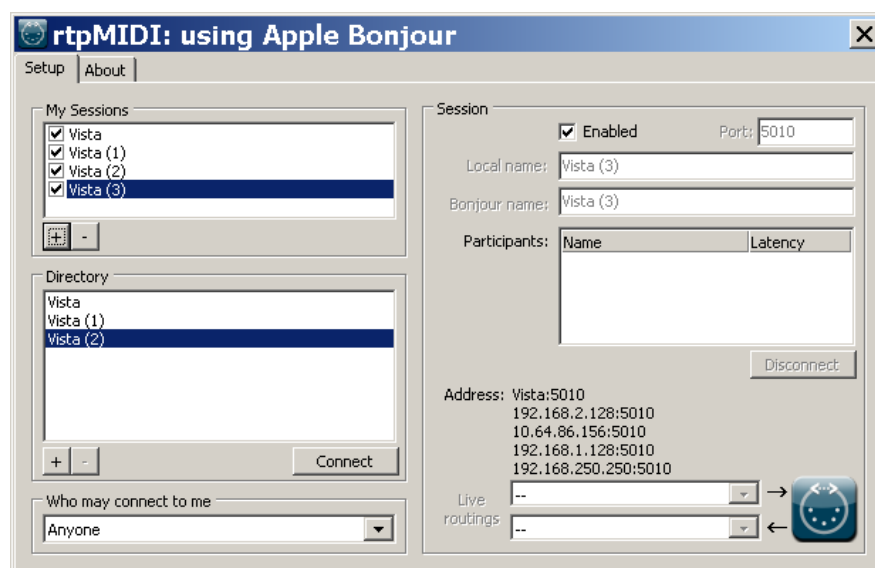

System MIDI Port Make sure that the Windows operating system does not assign one of the above MIDI sessions to the Windows default output device. A channel shift might be the result of this faulty assignment.

Open the Windows Control Panels after the above installation steps, open the Sounds and Audio Devices Panel and select the “Audio” tab.

In the example below, the MIDI playback default device is showing Vista (3), which is one of the rtp sessions. This is a faulty configuration.

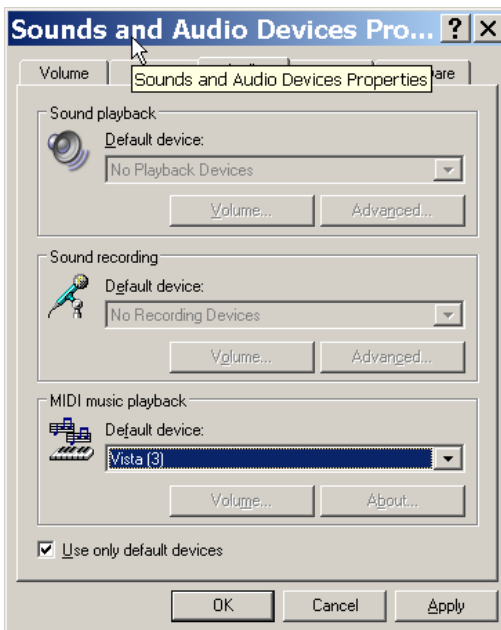

Choose another device if available, depending on the operating system and hardware, there can be a free onboard device. If there is no available alternative device, there are 2 alternatives :

1. choose a 5th session in the rtpMIDI setup and give it a different name, e.g. “SystemDefault”

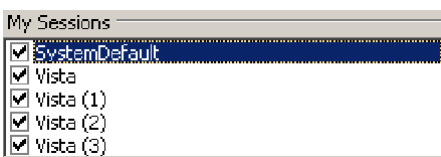

and choose it as default device



2. install a dummy output device, like MIDI Yoke and assign it as default device.



MIDI communication speed rtpMIDI allows to increase the communication speed. In order to change this parameter proceed as follows :

- Open rtpMIDI, press and hold CTRL, and double-click with the left button into the empty field to the right of the About tab. An advance tab will appear.

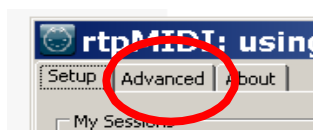
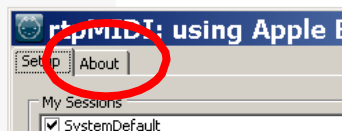

- Open the advanced tab and change the bitrate from the standard 31250 to maximum:

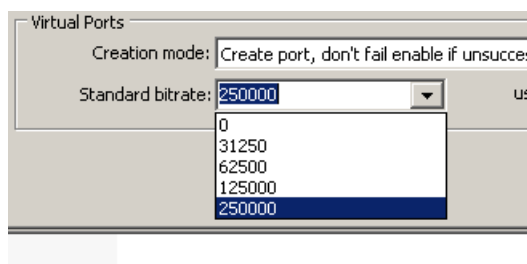

Specify MIDI Ports (i.e., MIDI ports used for DAW Control)

- While using rtpMIDI, add the following two lines into D950system.ini as shown below. (*Please note: the entry is case sensitive*).

```
[Midi]
DawPorts="Vista"
```

7.3 DAW Settings

rtpMIDI (to be installed on the DAW system running on Windows platform)

- Install rtpMIDI v1.1.4.235 (requires Bonjour V2.0.2.0 or later) - for installation details, please refer to the Vista Installation Note "Vista DAW Control with rtpMIDI"

Note *Mac workstations running on OS X do already provide the rtpMIDI- functionality.*

7.4 Connect the Sessions

Vista Assign each session in the My Sessions window on the Vista installation to the corresponding one on the DAW computer, which is also listed in the Directory window. In the example below it is :

- Vista to Mac DAW
- Vista (1) to Mac DAW (1)
- Vista (2) to Mac DAW (2)
- Vista (3) to Mac DAW (3)

Select the corresponding sessions in My Sessions and Directory and press “Connect”

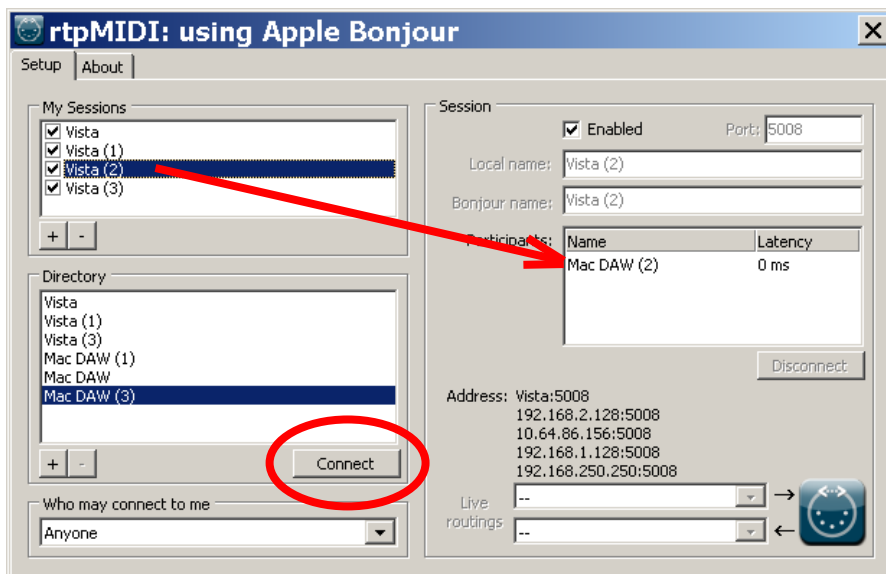

DAW In ProTools, set the according session in Peripherals - MIDI Controllers menu

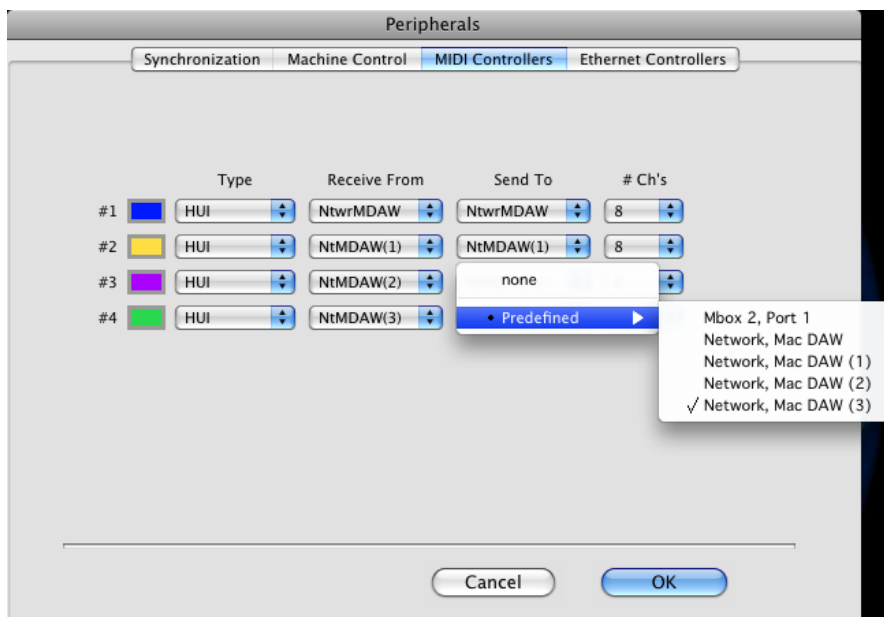

Please note : if Created Sessions do not show up in ProTools Dialog, make sure all Input Devices are activated as shown below :

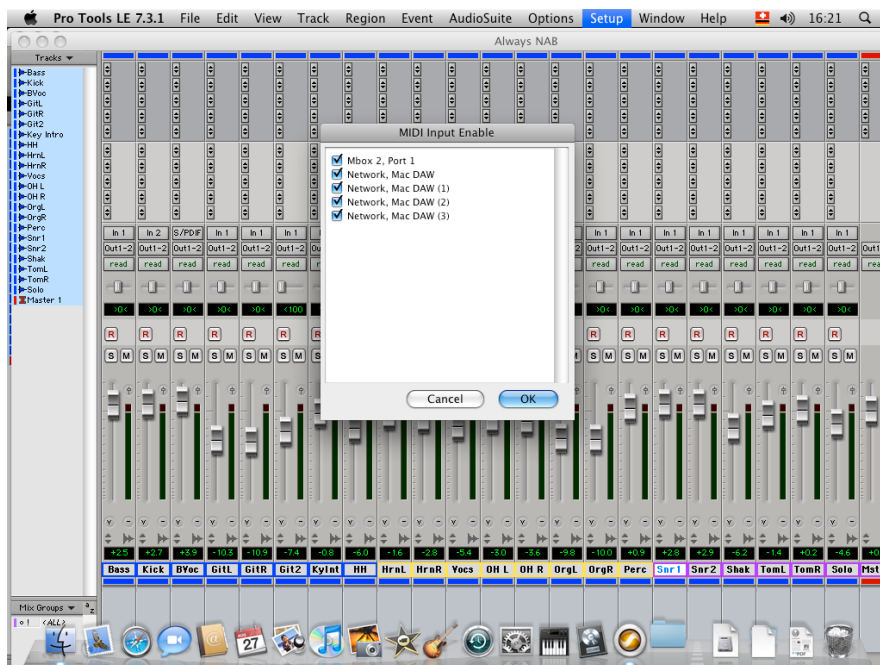

7.5 Control Keys in Channel Strip

Some of the channel strip keys on the desk surface can be used for DAW channel control:

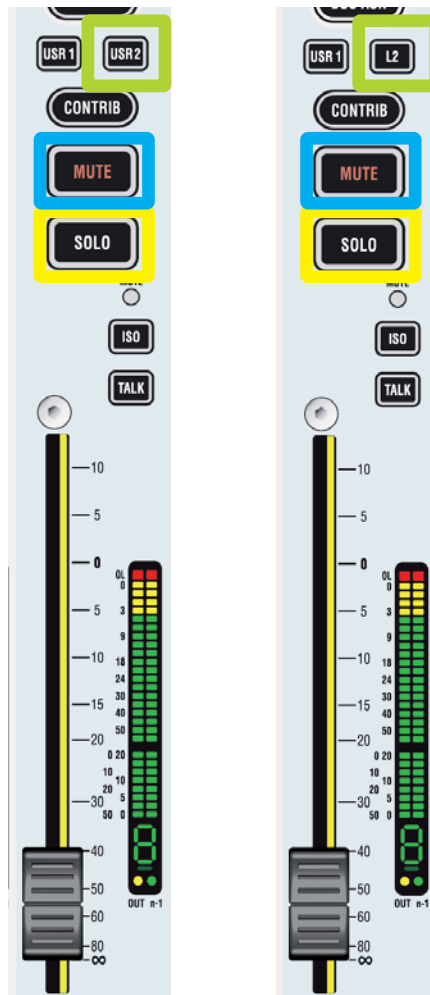

The marked keys can be used to control the following DAW functions:

| | |
|--------|--------------|
| Blue | Mute |
| Yellow | Solo |
| Green | Track Arming |

CHAPTER 8

| | | |
|----------|--|----------|
| 8 | RELINK (Resource Linking) | 2 |
| 8.1 | Input Patching | 2 |
| 8.2 | Output Patching | 3 |
| 8.3 | Mic Take-Over Procedure | 5 |
| 8.4 | Vista Restrictions | 8 |
| 8.5 | Technical Details | 9 |
| 8.5.1 | Vista I/O Sharing Setup | 9 |
| 8.5.2 | Restricting Shared I/O | 13 |
| 8.5.3 | Configuration Changes | 13 |
| 8.5.4 | Container.ini | 14 |
| 8.5.5 | D950System.ini | 15 |
| 8.5.6 | Tie Line Management | 15 |
| 8.5.7 | Control Network | 16 |
| 8.5.7.1 | Vista 5 BE in general | 16 |
| 8.5.7.2 | Vista 5 BE | 17 |
| 8.5.8 | IP Addresses | 17 |
| 8.5.9 | Audio Sync for all Systems | 17 |
| 8.6 | Messages from Other Systems | 18 |
| 8.7 | Labels from Other Systems | 18 |
| 8.8 | Locked Patch Points | 18 |
| 8.9 | Stereo and Surround Sources | 18 |

8 RELINK (RESOURCE LINKING)



Studer RELINK is an I/O sharing network technology available for all Studer products (OnAir consoles, Vista consoles and Route 6000) allowing direct access to sources and targets throughout the entire network – provided that the desired sources and targets are configured as ‘NetSources’ and therefore available for remote components of the system.

RELINK allows the design of ‘distributed’ audio network systems – enabling Studer products to access all sources and targets of the complete system, and therefore enhancing the flexibility of your facility.

Mic control takeover mechanisms are implemented on both the OnAir and the Vista consoles.

On the OnAir consoles, signaling is coupled with the I/O sharing, this means that red light, fader start and signaling connections are automatically following any console where the audio signal is used, and correctly applied to the source (Studio, CD Player, etc) from anywhere.

RELINK requires the following SW versions (or newer): Vista SW V4.1, OnAir SW V3.1, and Route 6000 SW V2.0.

RELINK is a software feature that, on the Vista side, does not depend on hardware, allowing systems still using a SCoreLive or Performa DSP core to be part of the network, as long as all the mic preamplifiers are of the D21m type.

8.1 Input Patching

With SW V5.2, a new source and target navigator menu has been introduced. It still is a pull-down menu, but it shows not only local sources and targets, but also sources and targets of all systems connected via the network. To see the connected systems, the marked button has to be clicked. All connected systems are then listed and their ‘NetSources’ are shown.

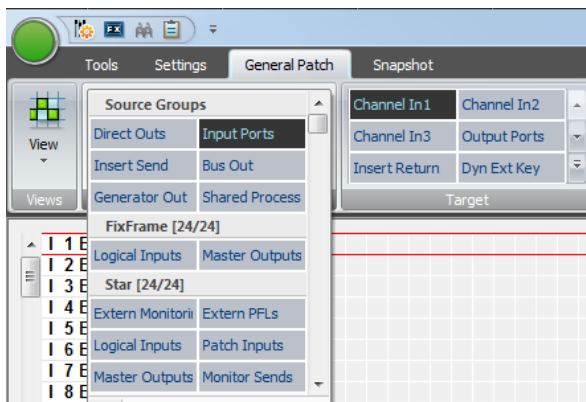
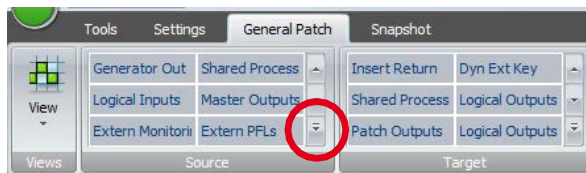

Shared inputs can be selected directly from any of the displayed systems. The sources of OnAir consoles – e.g. a DJ microphone – are appearing as ‘Logical Inputs’, and their output signals as ‘Master Outputs’. Please note that the names of the connected systems are only shown when the whole tab is unfolded. Right after the name of the system, two numbers are displayed which inform about the amount of connections to this system.

FixFrame [24/24]

The first number is the amount of *still available* mono audio channels coming from this system. The second number is the amount of *configured* mono audio channels coming from this system.

8.2 Output Patching

To get to the outputs of the connected RELINK-systems, the targets-tab has to be unfolded, so that the system names are displayed. Here, also the number of still available audio channels - and the number of totally configured audio channels to this system are listed.

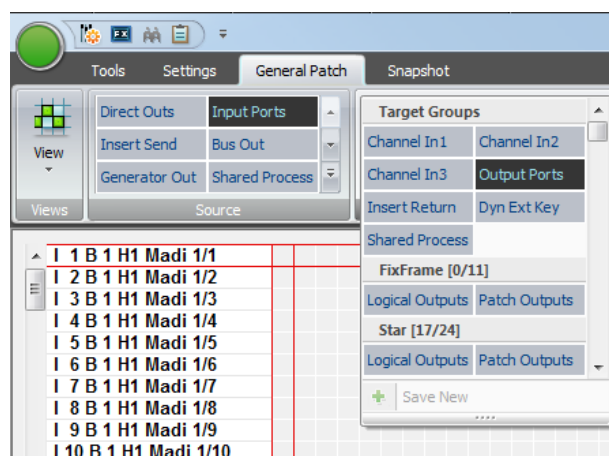

‘Set Outputs’ activates all preselected patch points to outputs on remote systems. This introduces an additional safety step in creating a remote patch connection.

The operator might want to switch several outputs to a different system (e.g. program outputs) at the same time. So when he is making the connections in the patch, they are marked in gray, indicating that the connection has not yet been established. Only when the ‘Set Outputs’ button is clicked, all the gray connections are set active at the same time. ‘Set Outputs’ only becomes active if some output patch connections are made to other systems.

This is only necessary when doing patch connections manually. When using snapshots, the connections are applied immediately.

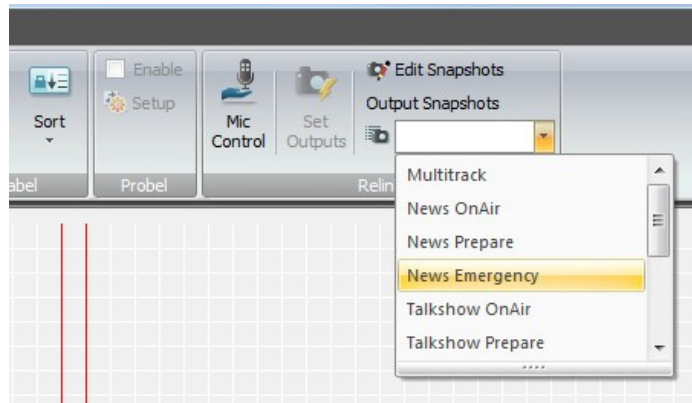

There is now also a new Edit dialog that allows saving multiple output patches to shared targets as 'Output Snapshots'. They must be given a name so that they can be recalled later from the lower right corner of the GC (Graphical Controller). An existing 'Output Snapshot' can be loaded as well, which means that the saved patch connections are not established but just shown in the gray, 'pending' state instead. In this state, the pending connections can now be edited and saved, e.g. under a new name.

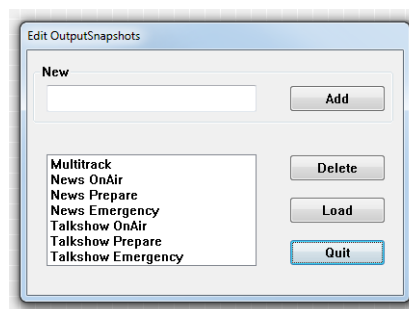

8.3 Mic Take-Over Procedure

The following status diagram shows how the mic control take-over mechanism is realized in the OnAir3000. This has to be followed, since it is firmly implemented in the DNet code.

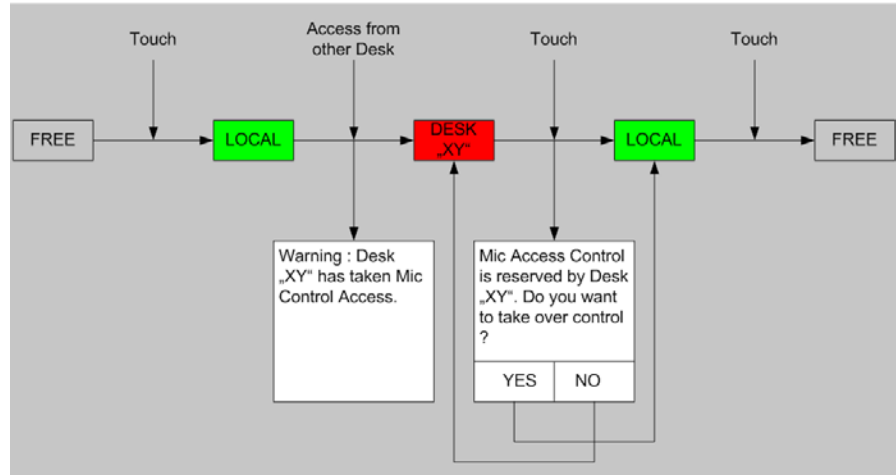

With the Vista desk, this dialog is handled in the channels Vistonics™ view in order to be able to link a number of channels and do the take-over handling for all of these channels at the same time (with a ‘gang’).

There is one difference to the OnAir behavior: When a mic source of another system is patched to a local input channel as long as the mic control is not taken by another desk (i.e., ‘free’ in the OnAir terminology), control is automatically given to the local Vista and the mic control parameters are displayed immediately.

There is a new parameter in the Vistonics™ view (Mic Ctrl) that allows setting the mic access control to ‘Free’, so that the mic can be controlled by other systems directly.

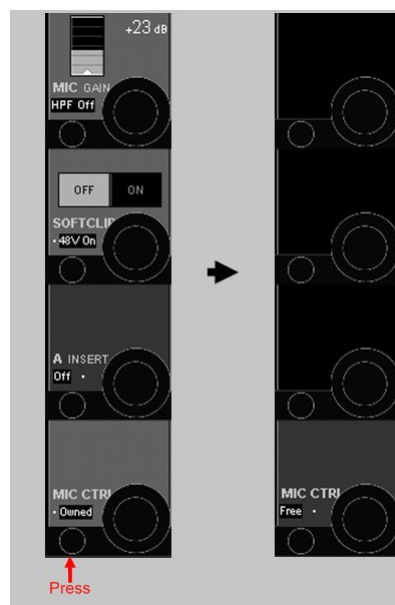

- A description of how all the necessary states look like is given below.
- 1a First, no mic is connected to the channel. Then, a shared mic currently in use

by another OnAir or Vista console is patched to input channel manually:

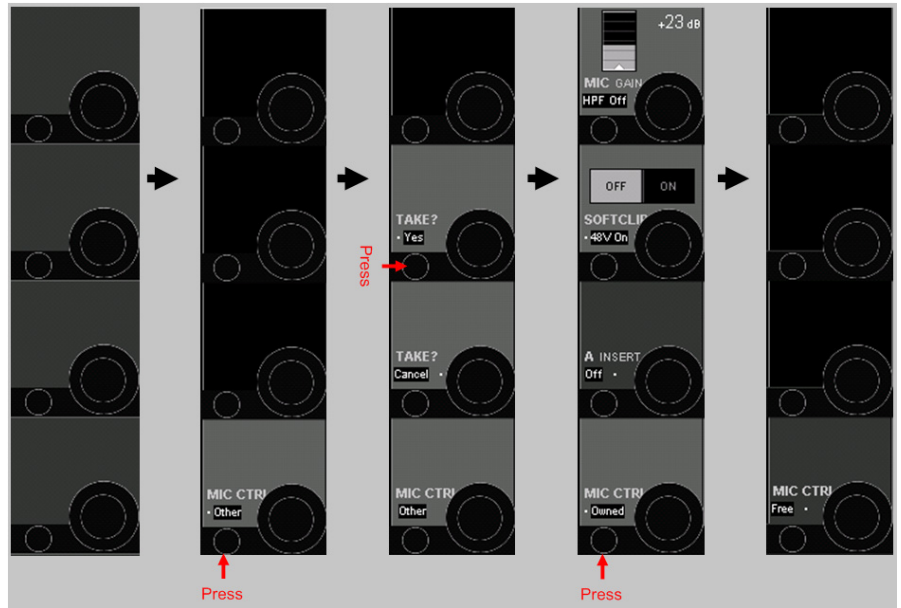

- 1b** First, no mic is connected to the channel. Then, a shared mic currently not in use by another OnAir or Vista console is patched to the input channel manually:

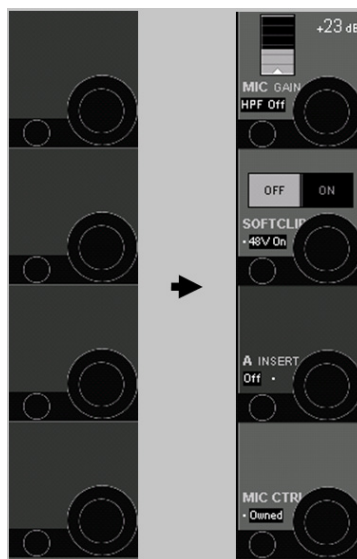

The same behavior is valid if one or more shared mics currently *not* in use by other systems is/are patched to the local input channel via a snapshot.

- 1c** If one or several shared mics are used on other systems but then get patched to a local channel via a snapshot, the following message appears on the GC:

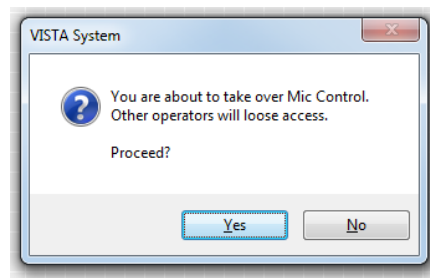

If confirmed with yes, the control for all the shared mics patched in the snapshot is taken over from the other systems.

- 2 A shared mic is patched to an input channel but then is taken over from a different desk:

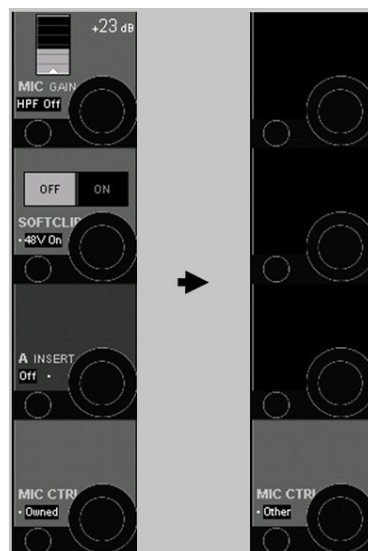

If this happens (on one single channel or also on several channels at the same time), a warning message appears on the GC screen:

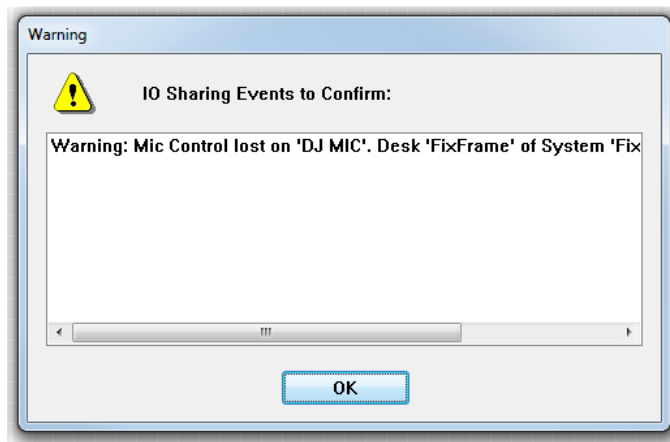

This is the window that shows all I/O Sharing events. It disappears after a click on the OK button.

8.4 Vista Restrictions

- Signaling, such as red light or fader start, is *not* combined with I/O Sharing.
- Vista systems cannot have any 'NETInputs' configured.
- 96 kHz sampling rate configurations on Vistas can only be used when *no OnAir console and no Router* is involved in the RELINK network. As long as only Vista systems are within the RELINK network, 96 kHz configurations can be used. However, *all Vistas* then need to run at 96 kHz.

8.5 Technical Details

8.5.1 Vista I/O Sharing Setup

ConfigTool for DNet Applications For configuring the tie lines necessary for I/O Sharing on the Vista system, we use the ConfigTool for DNet Applications known from the OnAir product range. This program now needs to be installed on the Vista's control computer (C:\Release ConfigTool\ConfigTool.exe). In the same folder there needs to be a file named container.ini with setup information for this DNet ConfigTool. Here is an example of the DNet ConfigTool container.ini file:

```
#####
#
# container.ini: Necessary for initialization of each container (.exe)
#
# Digital Mixing Console: VISTA
# Studer Professional Audio GmbH, Regensdorf, Switzerland
#
# Last modification      : Sep, 1st 2006
# Compatible with OATreeLib : V2.1
# Author                : SIA
#
# Rules:
# =====
# - always leave one blank before and after the <=> (e.g. systemid=1 NO!)
# - never change the left expression
# - the right expression of systemid, containerid, systemname
#   and containername MUST be defined
#
#####
```

```
# The systemid identifies the mixing console system to which this container
# belongs to. The systemid is a unique number within a network.
# The serial number must be in the range 1...255
```

systemid = 36 ← *this needs to be a unique number*

```
# The systemname identifies the mixing console system in a readable way
# and must be unique within a company resp. network. It is recommended
# not to use more than 8 characters due to visualization aspects.
# «Undefined» is not allowed!
```

systemname = «ConfigTool» ← *the name of the system*

```
# The containerid identifies this container
# and must be unique within the mixing console system
# This id is fixed to <10> (CORE) for all VISTA desks
```

```
containerid = 20 ← ,20' is always standing when the container.ini is belonging to a configtool
```

```
# The containername identifies this container in a readable way
# and must be unique within the mixing console system. It is recommended
# not to use more than 8 characters due to visualization aspects.
# «Undefined» is not allowed!
```

```
containername = «Config» ← the name of the container
```

```
# Multicast
```

```
# -----
```

```
# If you use IGMP multicasts instead of broadcasts in your network,
# you have to uncomment the lines below. It is possible that a
# container is member of one or more than one multicast groups.
```

```
#
```

```
# NOTE: For an optimal performance, make sure that all network resources
# (Switches, Routers...) support IGMP.
```

```
#
```

```
# NOTE: To avoid IP conflicts, check the available addresses for
# multicast groups (www.iana.org). Use preferable addresses from the
# local scope (239.255.0.0/16) described in RFC 2365.
```

```
#
```

```
# NOTE: If the multicast should reach computers beyond the local subnet
# Set MulticastTimeToLive > 1 (1 is default)
```

```
# MulticastGroup = 239.255.0.1
```

```
# MulticastGroup = 239.255.0.2
```

```
# MulticastGroup = 239.255.0.3
```

```
# MulticastTimeToLive = 10
```

```
# Multiple Network Adapters
```

```
# -----
```

```
# When more than one network adapter is enabled on the computer, the MAC Address has to be specified
```

```
#
```

```
# MAC = 00-1A-A0-B9-F9-88
```

Note: There needs to be a second `container.ini` file on the Vista's control computer – the one which is belonging to the mixing console application.

Start 'Config tool for DNet applications' in the Vista console's C drive (C:\Release ConfigTool\ConfigTool.exe)

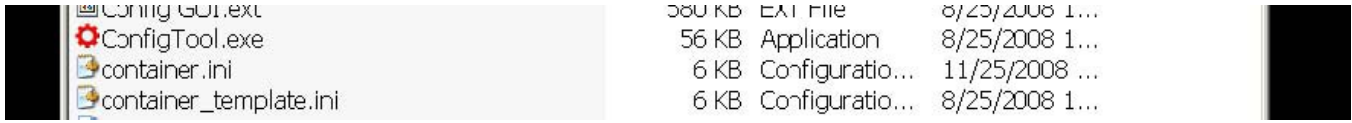

Select one of the DNet systems available in the network, select the appropriate Vista system.

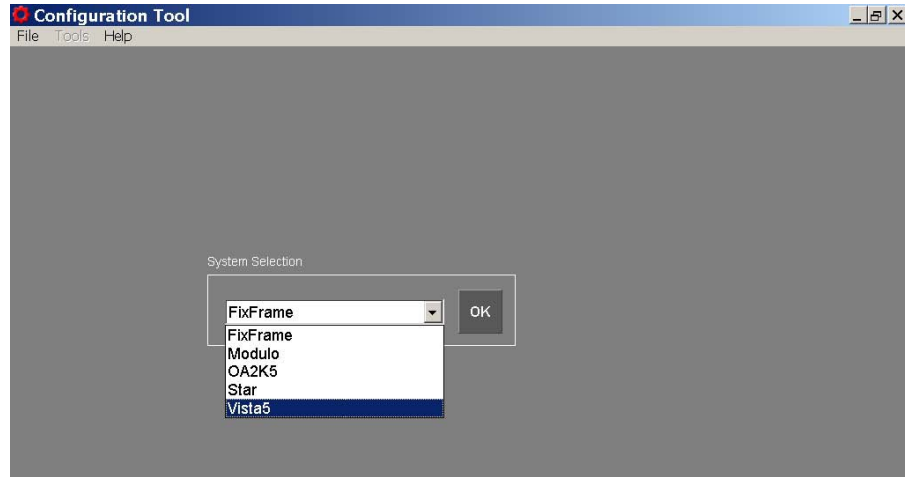

If the Vista or the other connected systems are not appearing, please refer to [chapter 8.5.4](#) to verify the settings in the Container.ini file. In the configuration tool, go to Physical Connections. Under Destination all HD links within your system are listed.

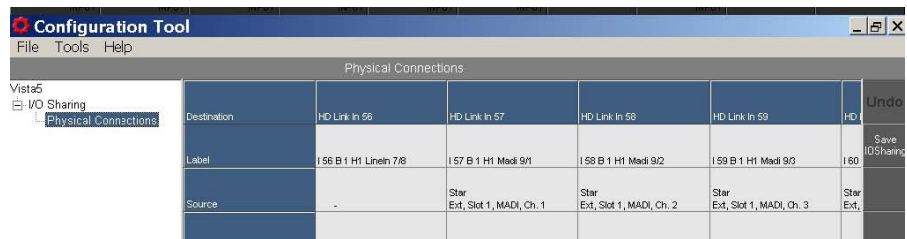

Select the physical inputs to be used as tie lines. Once they are configured as tie lines, they will no more be visible in the Vista general patch. *Configuration always takes place on the consumer system (target system).* Only the tie line inputs need to be configured, i.e., the tie lines that are directed *towards* our system. The tie lines that go away *from* our system are configured as inputs on the other systems, such as the router.

Select the appropriate *system* (e.g. the Star router, as shown below):

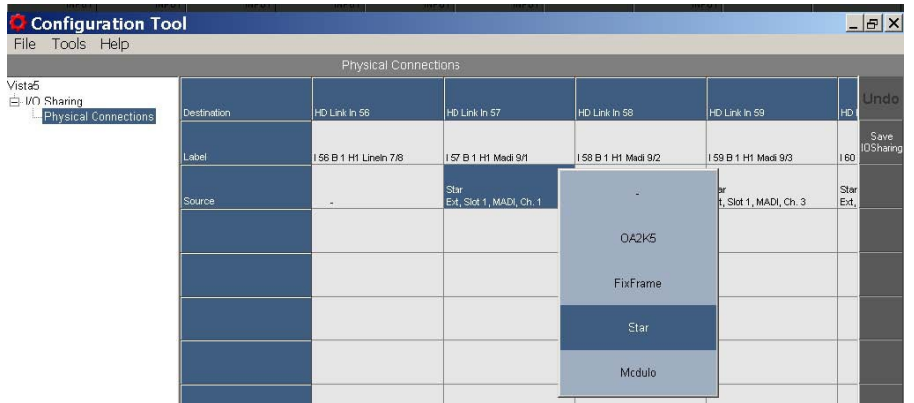

In the next step an I/O frame is selected (the external frame Ext in our example):

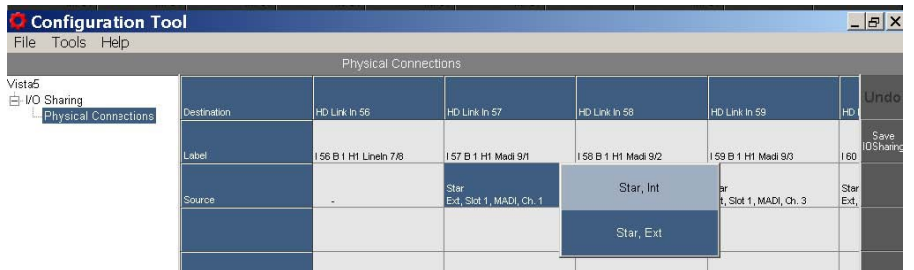

Now select the appropriate interfaces (e.g. MADI), one by one, for every single physical audio connection.

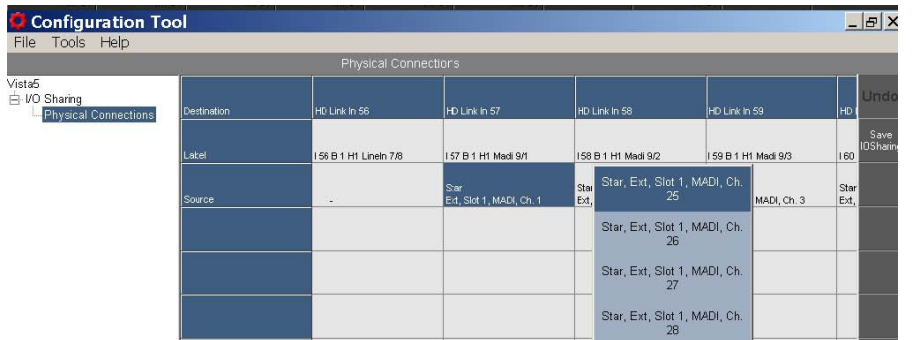

When finished, click the Save IO Sharing button at the right-hand edge of the Configuration Tool GUI.

This procedure only needs to be done once, during system setup. All these tie line configuration settings are saved on the consumer side and will remain after a system restart.

8.5.2 Restricting Shared I/O

Per default, all sources and targets attached to a Vista system can be seen and used by other systems that are part of the I/O Sharing network. Access to these I/Os may be restricted; they can then be used on the local Vista system only, but are not available to other systems within the network.

This is done with a text file containing a list of fixed labels of the I/Os that should be visible to others; the file must be named **SharedPatches.iosharing** and saved in the folder of the VMC configuration which it is valid for, such as **D950SystemDB\Config1**.

SharedPatches.iosharing Example:

```
...  
I 17 B 1 Ch17  
I 18 B 1 Ch18  
I 19 B 1 Ch19  
I 20 B 1 Ch20  
I 21 B 1 Ch21  
I 22 B 1 Ch22  
I 23 B 1 Ch23  
I 24 B 1 Ch24  
...
```

Notes: The I/O configured as tie lines must also be added in this file. If no file with this name is found in a configuration folder, all I/Os of this Vista system will be available for networked access.

8.5.3 Configuration Changes

Every VMC configuration change in a Vista console has an effect on the other consoles using this Vista's I/O at the same time. This means that an I/O can disappear and then reappear in a different constellation.

When using a file named **CommonSharedPatches.iosharing** located in the **D950SystemDB** folder, a number of sources and targets can be defined as I/O that must not change. This is useful for inputs or outputs that remain the same throughout all VMC configurations on the Vista. It contains a list of the fixed labels of the desired I/O.

CommonSharedPatches.iosharing Example:

```
...  
I 65 B 1 Ch65  
I 66 B 1 Ch66  
I 67 B 1 Ch67  
I 68 B 1 Ch68  
I 69 B 1 Ch69  
I 70 B 1 Ch70  
I 71 B 1 Ch71  
I 72 B 1 Ch72  
...
```

This file needs to be created manually. If no file with this name is found in a configuration folder, all I/O will be reinitialized by a configuration change.

8.5.4 Container.ini

The container.ini file for the Vista system is found in C:\D950System\. This file contains some important entries making the I/O Sharing work. Here a list of these entries:

```
#####
#
# container.ini: Necessary for initialization of each container (.exe)
#
# Digital Mixing Console: VISTA
# Studer Professional Audio GmbH, Regensdorf, Switzerland
#
# Last modification      : Sep, 1st 2006
# Compatible with OATreeLib : V2.1
# Author                 : SIA
#
# Rules:
# =====
# - always leave one blank before and after the '=' (e.g. systemid=1 NO!)
# - never change the left expression
# - the right expression of systemid, containerid, systemname
#   and containername MUST be defined
#
#####
```

```
# The systemid identifies the mixing console system to which this container
# belongs to. The systemid is a unique number within a network.
# The serial number must be in the range 1...255
```

systemid = 35 ← *this needs to be a unique number*

```
# The systemname identifies the mixing console system in a readable way
# and must be unique within a company resp. network. It is recommended
# not to use more than 8 characters due to visualization aspects.
# «Undefined» is not allowed!
```

systemname = «VistaV» ← *the name of the system*

```
# The containerid identifies this container
# and must be unique within the mixing console system
# This id is fixed to <10> (CORE) for all VISTA desks
```

containerid = 10 ← *,10' is always standing when the container.ini is belonging to a Vista desk*

```
# The containername identifies this container in a readable way
# and must be unique within the mixing console system. It is recommended
# not to use more than 8 characters due to visualization aspects.
# «Undefined» is not allowed!
```

containername = «Desk» ← *the name of the container*

```
# Multicast
# -----
# If you use IGMP multicasts instead of broadcasts in your network,
# you have to uncomment the lines below. It is possible that a
# container is member of one or more than one multicast groups.
#
# NOTE: For an optimal performance, make sure that all network resources
# (Switches, Routers...) support IGMP.
#
# NOTE: To avoid IP conflicts, check the available addresses for
# multicast groups (www.iana.org). Use preferable addresses from the
# local scope (239.255.0.0/16) described in RFC 2365.
#
# NOTE: If the multicast should reach computers beyond the local subnet
# Set MulticastTimeToLive > 1 (1 is default)

# MulticastGroup = 239.255.0.1 ← Multicast groups should all be disabled
# MulticastGroup = 239.255.0.2
# MulticastGroup = 239.255.0.3
# MulticastTimeToLive = 10

# Multiple Network Adapters
# -----
# When more than one network adapter is enabled on the computer, the MAC Address has to be specified
#
MAC = 00-AA-11-BB-22-CC ← in case of a Vista 9X/V with multiple network adapters, they need to be specified here
```

8.5.5 D950System.ini

The following entry needs to be added in the D950system.ini file:
IsRelinkActive=Yes

8.5.6 Tie Line Management

On every Vista console, tie lines need to be configured with the OnAir configuration tool. They may be any type of I/O, the most efficient of them are HD links giving 96 channels in both directions per Cat5 cable pair. Furthermore, MADi interfaces with a maximum channel capacity of 64/64 are quite popular for tie lines. MADi tie lines may also be configured to use less than 64 I/O – any desired number smaller than 64. AES/EBU or Line interfaces can also be used as tie lines if only a small number of audio channels needs to be shared, such as for transmission lines.

Tie line management is dynamic, therefore only the maximum number of audio channels used simultaneously needs to be considered.

FixFrame [24/24]

The number of the currently free tie lines is displayed in the sources/targets area of the general patch in the GC, with the total amount of configured tie lines This is shown for each connected system.

8.5.7 Control Network

All systems that need to be part of the I/O Sharing network need to be interconnected via Ethernet. On the Vista side, it is always the desk that needs to be networked.

- Vista desk networked (Ethernet)
- Tie lines between cores (MADI, AES, or HDLinks)
- DNET technology from OnAir product range
- Setup with the OnAir configuration tool also on the Vista side.

8.5.7.1 Vista 5 BE in general

Vista 5 BE is by default equipped with several network ports. There is a specific «Relink» Ethernet port which must be used to network the console to the Relink system. Normally, the Relink Ethernet port is connected to an Ethernet switch, where all other Relink devices are connected as well. In case the Relink network only consist of two Vista 5 BE consoles, also a X-over network cable between both Relink Ethernet ports of the two consoles could be used instead of an Ethernet switch.

8.5.7.2 Vista 5 BE

NETWORK CONFIGURATION RECOMMENDATION VISTA 5 BEBLACK - COMPACT INFINITY CORE

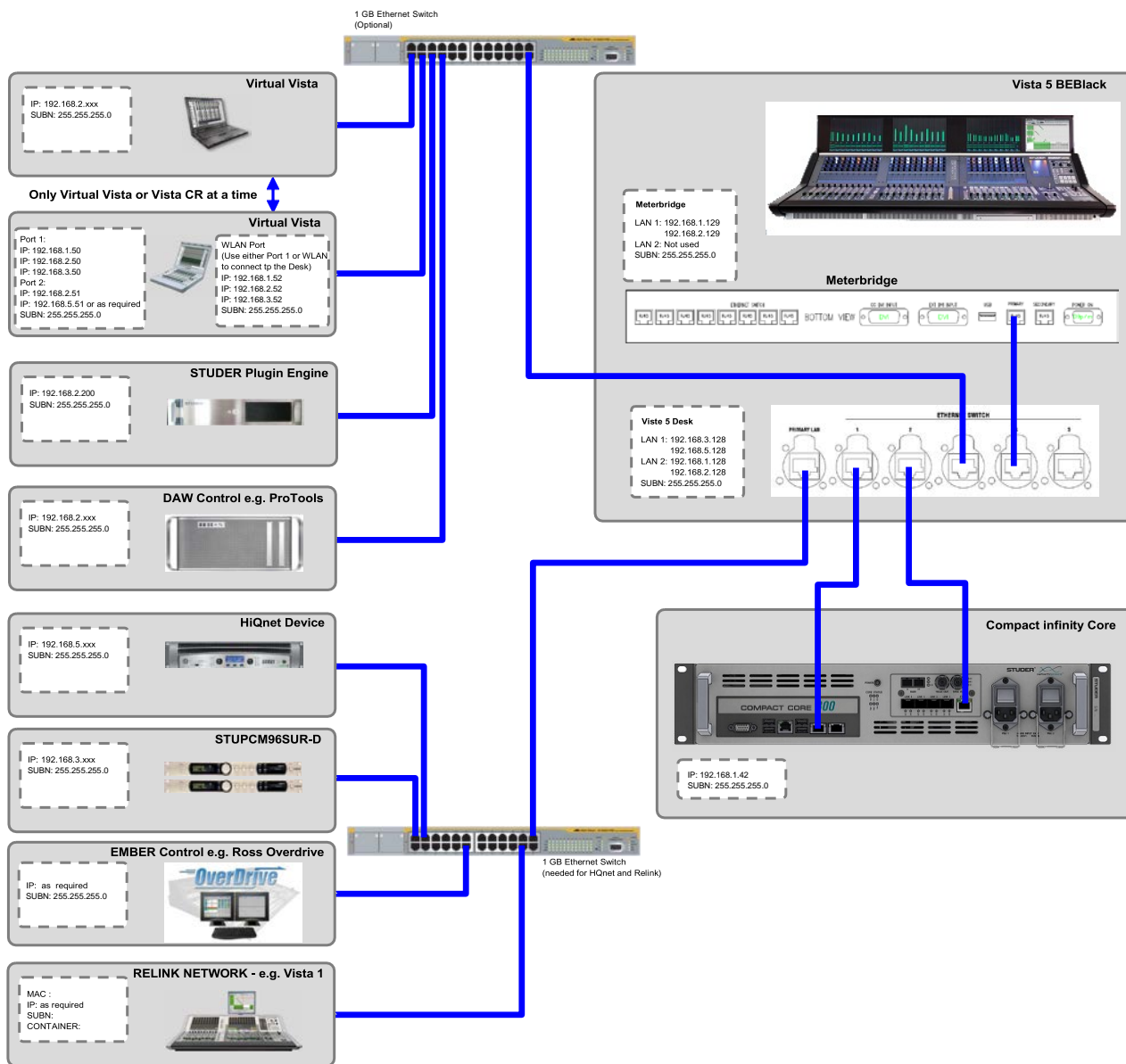

8.5.8 IP Addresses

See the blockdiagram above.

8.5.9 Audio Sync for all Systems

All systems being part of the network that can exchange audio via tie lines must be properly synchronized. The best option to do this is having a Studer D21 MasterSync unit feeding word clock in a star configuration to all the systems involved.

If a single system cannot be synchronized, either AES/EBU cards with SFCs or analog cards have to be used for tie lines.

8.6 Messages from Other Systems

When there are patch connections to other systems in the RELINK network – e.g. when using a mic input of another Vista or OnAir console – or when outputs are patched to a Route 6000 or to an other console, the local Vista will receive status messages from these systems.

Vista systems receive and display the following message types from OnAir and Route 6000 systems:

- Power loss on Core and I/O frames
- I/O hardware change
- System shut down

Vista systems send the following message type:

- System shut down

These messages are all displayed in the same type of window that also shows mic control messages:

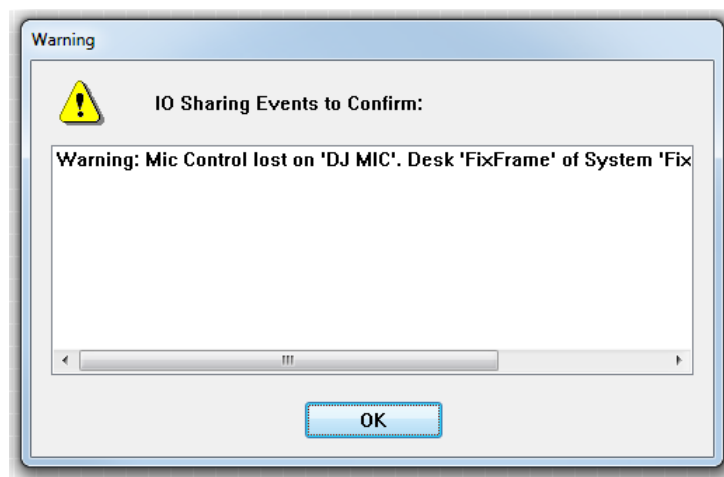

As long as no sources or targets of a remote system are used locally, no status messages of these systems are shown on the local Vista.

8.7 Labels from Other Systems

When patching remote inputs to a Vista system, the 'user label' of this input on the remote system is propagated to the Vista's input channel label display.

8.8 Locked Patch Points

Locked patch points are treated in the same way as local sources.

8.9 Stereo and Surround Sources

The following remote sources can also be in stereo or 5.1 surround formats:

- Vista Direct Outputs (Input, Group and Master channels)
- Stereo and Surround Inputs from OnAir consoles.

These sources can be patched directly, with one single patch point connection, to a local target.

Chapter 9

| | | |
|----------|--|----------|
| 9 | Vista FX..... | 2 |
| 9.1 | Introduction | 2 |
| 9.2 | Hardware | 3 |
| 9.3 | Setup with SCoreLive..... | 4 |
| 9.3.1 | Hardware setup..... | 4 |
| 9.3.2 | Network configuration | 5 |
| 9.3.3 | Files on the Vista control PC..... | 6 |
| 9.3.4 | Files on the redundant Vista control PC..... | 7 |
| 9.3.5 | Setup process in Vista application | 7 |
| 9.3.6 | Startup | 8 |
| 9.4 | Hardware setup with Infinity Core | 9 |
| 9.4.1 | Hardware setup..... | 9 |
| 9.4.2 | Network configuration | 10 |
| 9.4.3 | Files on the Main Vista control PC..... | 10 |
| 9.4.4 | Files on the redundant Vista control PC..... | 11 |
| 9.4.5 | Setup process in Vista application | 11 |
| 9.4.6 | Startup | 12 |
| 9.5 | Effect routing..... | 13 |
| 9.6 | Operation | 14 |
| 9.6.1 | Engine setup..... | 14 |
| 9.6.2 | General Patch | 16 |
| 9.6.3 | Create Send Return Effects | 19 |
| 9.6.4 | Create Insert Effects | 21 |
| 9.6.5 | Loading Effects | 23 |
| 9.6.6 | Effect parameters | 25 |
| 9.6.6.1 | Halls, Plates and Chambers | 25 |
| 9.6.6.2 | Rooms | 28 |
| 9.6.6.3 | Environments | 30 |
| 9.6.6.4 | Chorus / Flange | 30 |
| 9.6.6.5 | Delay | 30 |
| 9.6.6.6 | Resonance | 31 |
| 9.6.6.7 | Reverse..... | 31 |
| 9.6.6.8 | Pitch Shift..... | 32 |
| 9.6.6.9 | Pitch Effects | 32 |
| 9.6.6.10 | Tap Control..... | 34 |
| 9.6.7 | Copy/Paste | 34 |
| 9.6.8 | Snapshot operation | 36 |
| 9.6.8.1 | Snapshots and Presets..... | 36 |
| 9.6.8.2 | Static Automation..... | 36 |
| 9.6.9 | Dynamic automation | 38 |
| 9.6.10 | Offline operation..... | 38 |
| 9.7 | Preset Overview..... | 39 |
| 9.9 | Specifications | 40 |

9 Vista FX

9.1 introduction

Legendary Lexicon® Reverbs and Effects

Software V4.9 and newer allows to have highest quality multi-effect units deeply integrated into the Vista mixing system.

Multi-effect units are useful for any mixing application, but most importantly for sound reinforcement and live broadcast productions. In general, multi-effect units provide effects processing for the most commonly used time based effects, such as : Reverb, Flange/Chorus and Delay. Studer Vista FX is the result of a collaboration between Studer and Lexicon, which provides broadcast quality effects-processing, controlled from the intuitive Vistonics interface of the Vista console.

The processing is carried out in Vista FX DSP units which are linked to the SCoreLive. These hardware units are based on the legendary Lexicon PCM96 Surround DSP-platform, and therefore provide all PCM96 Surround effect preset categories :

- Hall & Random Hall
- Concert Hall
- Plate
- Chamber
- Room
- Dual Delay
- Random Delay
- Chorus / Flange
- Resonant Chords
- Reverse
- Pitch Shift

Vista with SCoreLive The Vista FX units are optional hardware units which can either be part of a newly ordered mixing system, or they can be added to any existing Vista mixing system which is based on the SCoreLive DSPengine.

Vista with Performa Core Vista mixing system based on the older Performa DSP engine cannot be equipped with Vista FX.

Vista with Infinity Core Vista mixing systems based on the Infinity Core can make use of the original Lexicon PCM 96 Surround units to achieve the Vista FX functionality. Two Lexicon PCM 96 Surround units have the same FX resources as one Vista FX unit.

9.2 hardware



The Vista FX hardware is coming in a housing which uses 2 RU in a 19" rack. It has the Studer partnumber **5003726**.

One such hardware unit is the equivalent of two Lexicon PCM96 "engines". Up to three such Vista FX units can be combined, to provide Lexicon effects in the equivalent of six Lexicon PCM96.

Front LED's The faceplate provides a green and a red LED for each of the redundant powersupplies, "Power1" and "Power2". The green LED indicates 'ok' state of the powersupply, the red LED indicates the 'fail' state, in case of a powersupply failure or in case of a loss of power.

Connectors On the rear of the unit the following connectivity is provided :

- 2x mains inlet with switches for redundant power supplies
- 8x RJ45 HD-Links for audio connection to the dsp engine as well as slave units.
- 4x RJ45 Ethernet Control Ports (A and B). Two of each for daisy chaining.

Number of Slaves switch A rotary switch allows to set the "Number of Slaves" (the number of additionally Vista FX units, connected to the "Master" unit). Range : **0..2**.

Lock LED's These LED's inform about the HD-Link Lock status of the audio connections. A solid illuminated LED means that the HD-Link is locked, and therefore the audio connection is established and ok. While the unit is booting and the audio connection is being established, the LED is flashing. When the LED stays dark, no connection is established or the Lock status has been lost. (e.g. due to the connected unit being powered down, or an error in the HD-Link connection).

Core/Master LED - Status of the HD-Link to the DSP Core

Slave1 LED - Status of the HD-Link to the first Vista FX slave unit

Slave2 LED - Status of the HD-Link to the second Vista FX slave unit

Slave3 LED - currently not used.

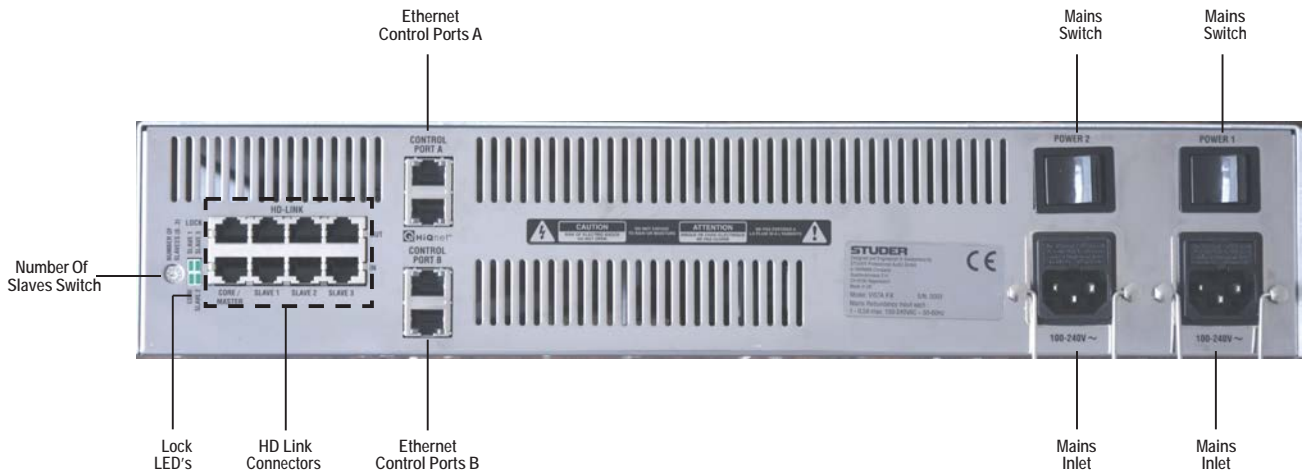

9.3 setup with sCoreLive

9.3.1 hardware setup

Necessary connections There are two types of connections that need to be established :

- Audio connections to the DSP Core
- Control connection to the Vista desk

Audio connections The audio connections are done by using the HD-Link ports of the first free DSP card. It is recommended to use the upper two RJ45 connectors – as they automatically detect the Vista FX hardware. Synchronising is automatically done through the HD-Link. In addition to the above cabling, it is also necessary to modify the DSP setup of the SCoreLive : there need to be 48 input and output ports defined on the first DSP card that had no I/O allocated beforehand.

Master Box Setup Connect the „Core/Master“ IN and OUT of the master box with the HD-Link ports of the DSP card. Set the „Number of Slaves“ rotary switch to the number of connected slave FX boxes.

Slave Box Setup Connect the “Core/Master” IN and OUT of the Slave x box to the “Slave x” OUT and IN of the master box.
“Number of Slaves” of Slave FX boxes must be set to 0.

Control connection The control connection to the desk is using Harman’s HiQNet protocol and needs a simple Ethernet connection.

Setup All control ports of all units need to be daisy-chained with CAT5 cables. The first or the last port then needs to be connected to the Vista desk.

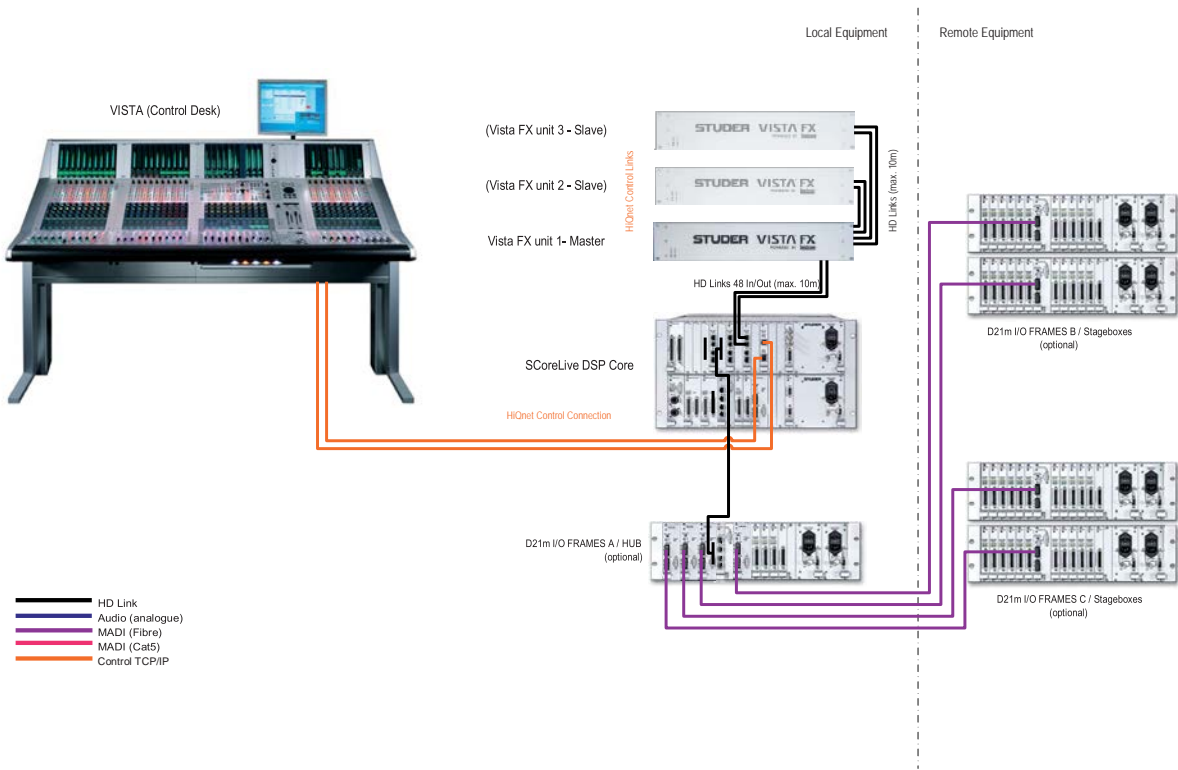

9.3.2 Network configuration

Vista control PC requirements

We recommend using the subnet “xxx.xxx.3.xxx” on the used Vista network adapter by default for all Vista FX units. On some Vista systems (e.g. Vista 5) the subnet “xxx.xxx.3.xxx” does not yet exist. There, we recommend defining this additional subnet “xxx.xxx.3.xxx”. See note below on how to add a subnet.

Add a subnet

This requires changes to the protected part of the operating system, so it is recommended that the windows operating system be restarted at this point. When the desk has rebooted with the Vista application closed:

- Open your secondary network adapter.
- Click Properties.
- Click Internet Protocol (TCP/IPv4) then click Properties. You should see the IP address 192.168.2.128 configured
- Click Advanced.
- On the IP Settings tab, click Add...
- Type in the new IP address (192.168.3.128 – subnet mask 255.255.255.0) then click Add.
- Click OK to close the Advanced TCP/IP settings window.
- Click OK to close the Internet Protocol (TCP/IP) Properties window.
- Click OK to close your network adapter properties window.

Please verify the added subnet settings.

In order to make these changes fixed when the desk is power cycled, the EWF system must be updated.



Do not share the same HiQNet connection with other desks having Vista FX units connected as the systems sees all Vista FX units found in the network as local hardware.



Do not connect the Vista FX units to a DHCP network. This will result in unstable connectivity of the Vista FX units.

9.3.3 Files on the Vista control pC

FXConfiguration file: The Vista desks D950System folder must contain two files:

FXConfiguration.xml and
FXConfiguration.xdr.

If they are not available in there, they can be copied from the current SW version folder Vista/XML.

The ip address must be edited according to HiQnet entry in D950System.ini.

D950System.ini file: The HiQNet-node configuration in the D950system.ini file needs to be adapted.

[Hi Qnet]

Node=555 ← *this ID must be different on the redundant PC*
 DhcpEnabled=No ← *must be set to "No"*
 IpAddress=192. 168. 3. 128 ← *this needs to be the used subnet*
 ReconfigureDeviceInDiffSubnet=Yes ← *must be set to "Yes"*
 ; old entries for compatibility
 SubnetMask=255. 255. 255. 0 ← *must be set to exact this value*
 Gateway=0. 0. 0. 0 ← *must be set to exact this value*
 Serial Number=001B214F13C6 ← *must be set to exact this value*

Make sure an "s" is added to the relevant DSP card serial port. e.g. if the Vista FX unit is connected to the DSP card in slot 4, the following entry is necessary:

[d950Serial Ports]

10= {S} TCP4 slot=4 ← *must be set to "s"*

The following entries define the DSP card slot number and HD-Link port number where the Vista FX units are connected to. The default entries are empty, allowing automatic discovery via D21m. These settings can also be used to configure Vista FX units being connected to the second HD-Link (port 1) of a DSP card, where no D21m communication can be used and therefore Vista FX units cannot be detected automatically. For Offline usage of Vista FX with e.g. a Virtual Vista where no Vista FX units have been connected before, manually entered numbers will enable to Vista SW to emulate the FX units.

[LexiconFX]

ConnectedDspCardSlot = **← empty or 1-9**
 ConnectedDspCardPort = **← empty or 0-1**

9.3.4 Files on the redundant Vista control pC

On the redundant PC there must be an additional set of the two FXConfiguration.xml and FXConfiguration.xdr files in the D950System folder.

If both PCs share the same HiQNet subnet, then the files can be identically. This is the recommended setting for the redundant PC setup.



Make sure that the HiQNet node ID (555 is default) of the redundant PC is different to the main PC.

9.3.5 setup process in Vista application

Setup Dialog in the Vista application : Once all the above is done correctly, the Vista application can be started and the “FX Audio Setup Dialog“ can be run. This dialog is found in the Settings Tab menu, when logged-in as System Administrator.

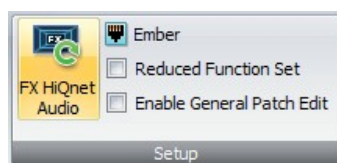

FX Audio Setup Dialog Menu

The FXAudioHiQNetSetup – window opens up, and the “Start Setup” button can be pressed.

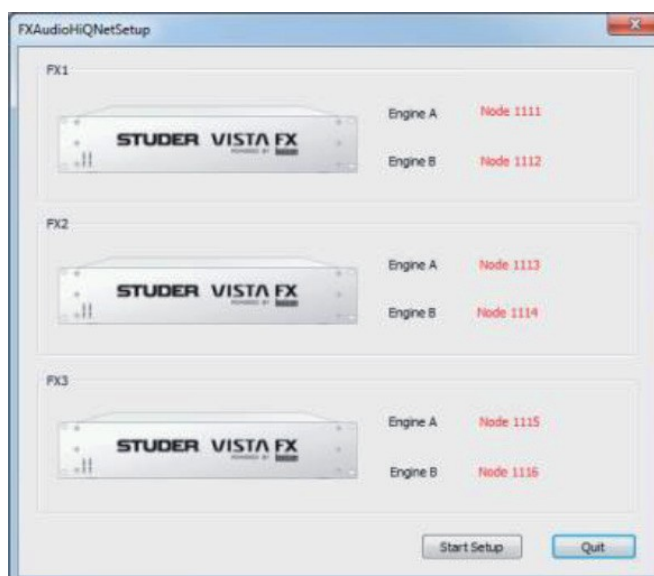

Setup Window

Then all the connected Vista FX hardware units are detected and become available for the Vista mixing system. This is then displayed in the Surveyor window :

Surveyor View

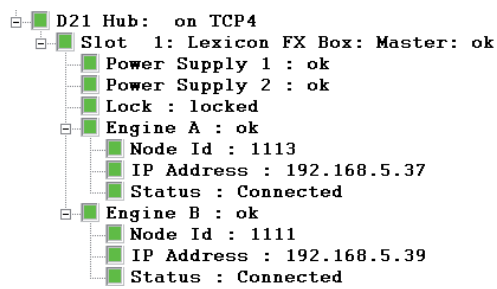

When there is any change in the IP configuration, the system prompts to ask the user to run the Audio Setup Dialog again.

9.3.6 startup

Please note that all the above setup process needs to be done only once, as the initial setup. From then on, the Vista mixing system will always provide the FX, every time the system is started.

Start-up time of the Vista FX unit

During the power up of the Vista FX hardware unit, its lock LEDs of the active HD link connections are flashing. It takes about two minutes for the unit to become operational. A successful start-up and lock situation is indicated with a steady ON of the Lock LED.

9.4 hardware setup with infinity Core

As with the Infinity Core there are no HD-Links available, it is not possible to use the Vista FX unit. As a replacement, pairs of the original Lexicon PCM 96 Surround (digital) units can be used - as they feature AES I/O ports instead of the HD Links. This is possible starting with Vista SW version 5.2 and higher.



Please note that the PCM 96 units can only be used in pairs (one pair, two pairs or three pairs as the maximum) since the resources of a PCM 96 pair equal the resources of one Vista FX unit.

9.4.1 hardware setup

Necessary connections There are two types of connections that need to be established :

- Audio connections to the Infinity Core via D23m frame
- Control connection to the Vista desk

Audio connections The audio connections are done by using AES I/O ports of one or several D21m AES I/O cards. These I/O ports need to be specified in the D950system.ini file. Synchronising is done through the AES input signal into the PCM 96 unit, which needs to be set-up accordingly.

Control connection The control connection to the desk is using Harman's HiQNet protocol and needs a simple Ethernet connection.

Setup All control ports of all PCM 96 units need to be daisy-chained with CAT5 cables. The first or the last port then needs to be connected to the Vista desk.

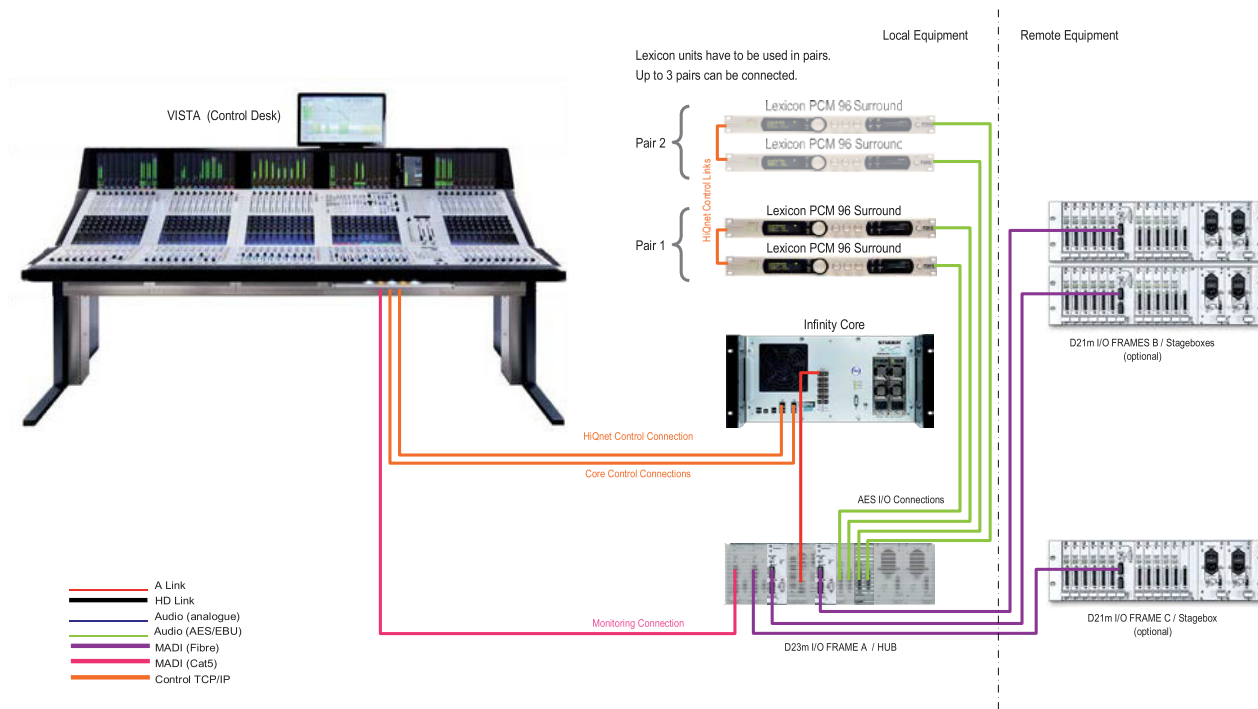

9.4.2 Network configuration

Vista control PC requirements We recommend using the subnet “xxx.xxx.3.xxx” on the used Vista network adapter by default for all PCM 96 units. This subnet is already existing on all Infinity Series systems.

9.4.3 Files on the Main Vista control pC

FXConfiguration file: The Vista desks D950System folder must contain two files:

FXConfiguration.xml and
FXConfiguration.xdr.

If they are not available in there, they can be copied from the current SW version folder Vista/XML.
The ip address must be edited according to HiQnet entry in D950System.ini.

D950System.ini file: The HiQNet-node configuration in the D950system.ini file needs to be adapted.

[HiQnet]

Node=555 ← *this ID must be different on the redundant PC*
DhcpEnabled=No ← *must be set to “No”*
IpAddress=192.168.3.128 ← *this needs to be the used subnet*
ReconfigureDeviceInDiffSubnet=Yes ← *must be set to “Yes”*
; old entries for compatibility

SubnetMask=255.255.255.0 ← *must be set to exact this value*
 Gateway=0.0.0.0 ← *must be set to exact this value*
 SerialNumber=001B214F13C6 ← *must be set to exact this value*

The following entries define the I/O where the PCM 96 units are connected audiowise :

[LexiconFX]
 AudioConnectionType=AES ← *must be set to "AES"*
 AESStartInterface= ← *optional, 0 is default*
 EnginesAvailable= ← *is automatically set by Vista SW*

9.4.4 Files on the redundant Vista control pC

On the redundant PC there must be an additional set of the two FXConfiguration.xml and FXConfiguration.xdr files in the D950System folder.

If both PCs share the same HiQNet subnet, then the files can be identically. This is the recommended setting for the redundant PC setup.



Make sure that the HiQNet node ID (555 is default) of the redundant PC is different o the main PC.

9.4.5 setup process in Vista application

Setup Dialog in the Vista application : Once all the above is done correctly, the Vista application can be started and the "FX Audio Setup Dialog" can be run. This dialog is found in the Settings Tab menu, when logged-in as System Administrator.

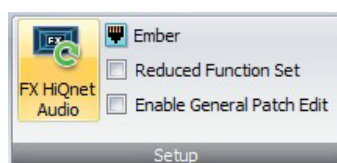

FX Audio Setup Dialog Menu

The FXAudioHiQNetSetup – window opens up, and after specifying the AES I/O ports where the PCM 96 units are connected, the "Start Setup" button can be pressed.

Setup Window Then all the connected Vista FX hardware units are detected and become available for the Vista mixing system. This is then displayed in the Surveyor window :

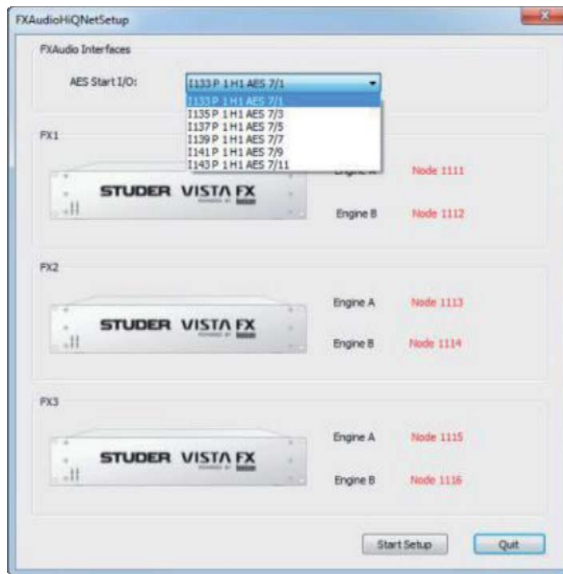

Surveyor View

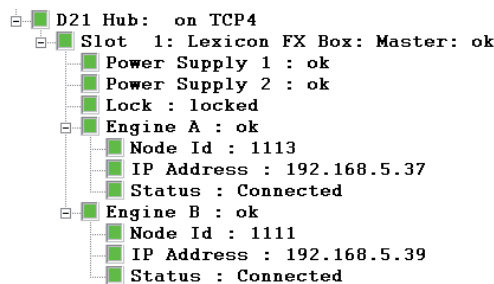

When there is any change in the IP configuration, the system prompts to ask the user to run the Audio Setup Dialog again.

9.4.6 startup

Please note that all the above setup process needs to be done only once, as the initial setup. From then on, the Vista mixing system will always provide the FX, every time the system is started.

Start-up time of the PCM 96 units During the power up of the PCM 96 units, their displays will show when they have fully started up.



Please be aware that during operation none of the front panel controls must be used. Operating the PCM 96 front panel controls could lead to inconsistent operation !

9.5 effect routing

The Lexicon PCM96 Surround provides the categories of effects presets as mentioned in chapter 1. The routing of these effect-blocks can vary in terms of number of inputs and outputs. This can then allow a number of effects to be processed simultaneously on the same unit. In the PCM 96 Surround, the effects can also be cascaded, leading to the following variety of possible routings :

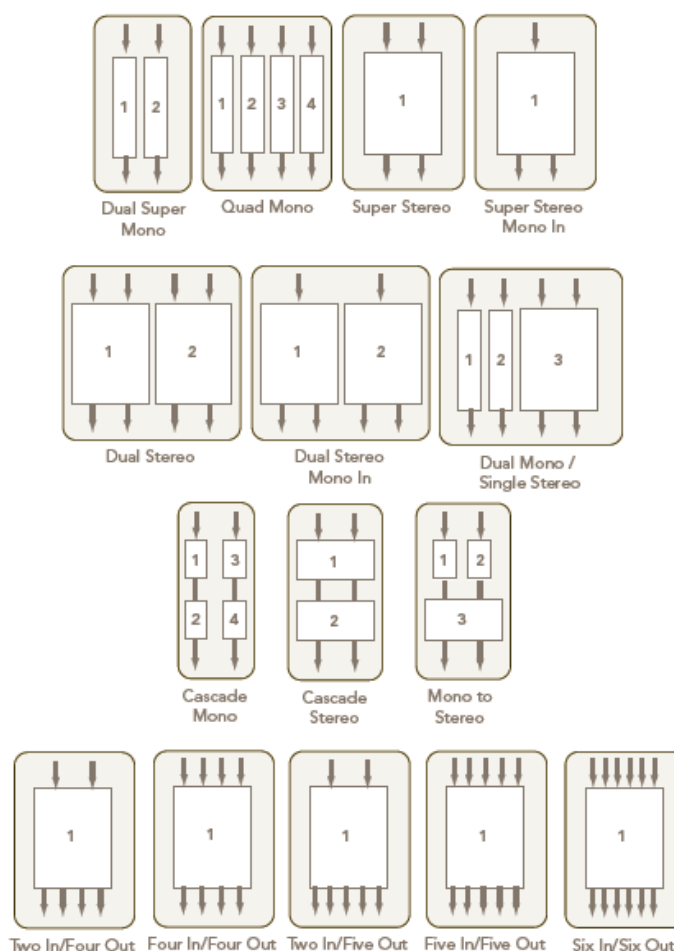

With the operating philosophy in the Vista consoles, only a subset of these routing possibilities are available for Vista FX. These are :

- **Dual Stereo**
- **Quad Mono**
- **Single Two In Five Out**
- **Single Five In Five Out**
- **Single Six In Six Out**

Once the structures of the effects engines are defined, their inputs as well as outputs are available in the general patch of the Vista consoles GC.

To make working with Vista FX as easy and straightforward as possible, Vista FX are intended to be used in two ways :

Send-Return Effects

This is the effect structure that has been used in the analog world with traditional outboard effects - using an Aux bus to add signal from several channels, and then feed it from the Aux to one single effect unit. To get the 'wet'-only

effect signal back into the mix, an input channel (“effect-return”) has to be used.

Since this is still a practical way of working, and because many operators are very familiar with this concept, it is also used for Vista FX.

Insert Effects When an effect is only used for one single channel, it can be patched into the channels insert path. The effect then cannot be used for any other channels.

These two effect concepts can be used with Vista FX, and are explained in more details in the following chapter.

9.6 Operation

As oposed to the initial setup process, which is described above - here, the actual operation with Vista FX is explained.

9.6.1 engine setup

As the starting point for working on a session by session basis with Vista FX, the engine setup needs to be carried out.



By pressing the **FX** button in the Ribbon Tools Tab, the Vista FX Engine Setup window opens up.

The Vista FX Engine Setup window has three tabs : **FX1, FX2, FX3** Each tab is representing one Vista FX hardware unit. Every unit has two engines : **Engine A** and **Engine B**, each engine being one PCM96 Surround processing board.

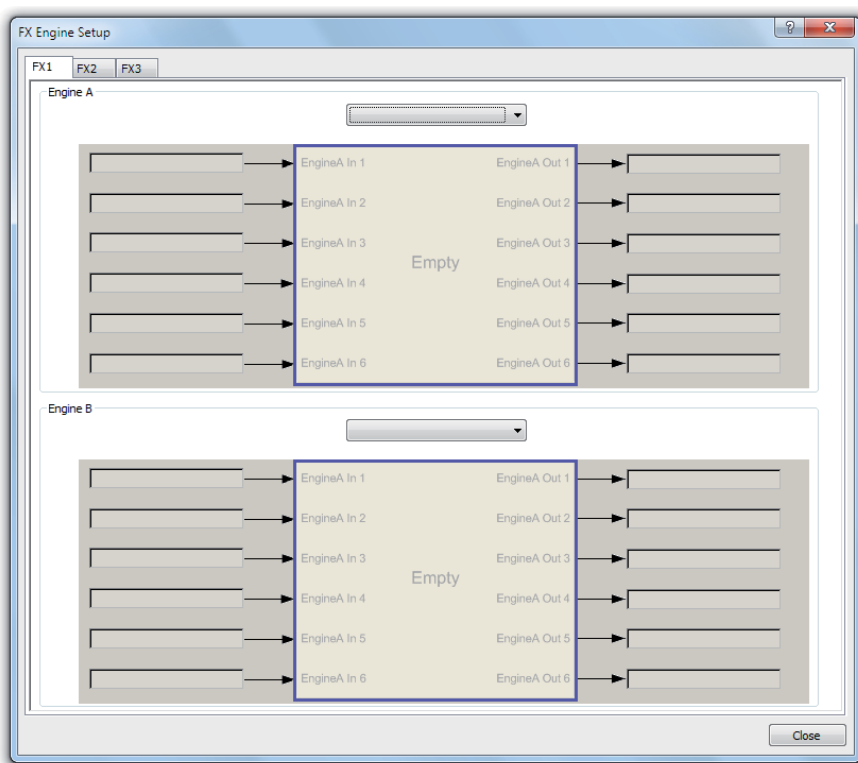

Clicking on the pull-down menu, the choice of engine setups is presented, and one can be chosen to be applied into the desired engine.

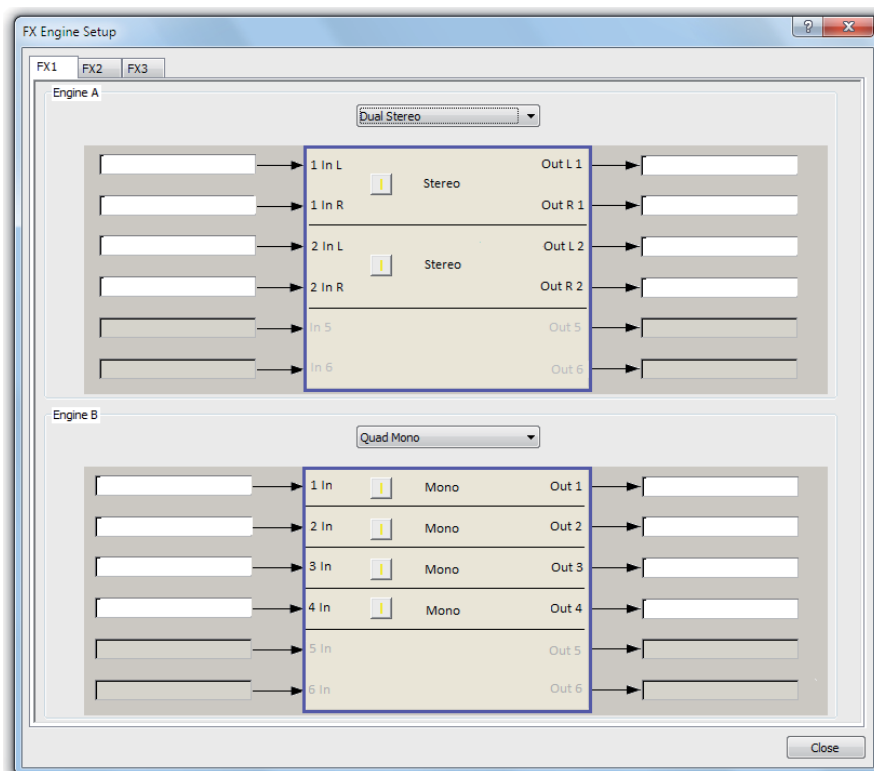
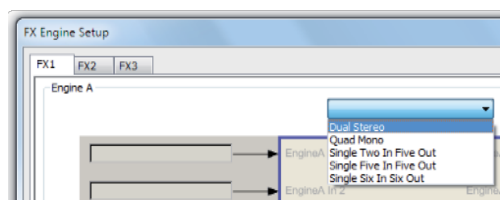

Dual Stereo setup : This setup provides two stereo effect blocks for one engine. It is suitable for usage of a stereo effect, e.g. a stereo reverb. Since two engines are available, the user has the benefit of running two different stereo effects at the same time. The stereo effect then can be used as a send-return effect, or also as an insert effect for a stereo channel.

Quad Mono setup : This provides four mono effect blocks for one engine. It is the preferred choice when using insert effects for mono channels. With both engines in this setup, up to eight insert effects can be provided. Of course, also the combination of different setups within one hardware unit is possible (see screenshot above).

Single Two In Five Out setup : This setup can be used to create a five channel surround effect with a simple stereo signal as the source. A nice way to create 5.1 ambiance for a stereo track.

Single Five In Five Out setup : This setup allows to create real surround effects. A 5.0 surround input signal will create a 5.0 effect signal.

Single Six In Six Out setup : For this setup only pitch shift effects can be loaded to treat a 5.1 signal in

terms of pitch. For surround reverbs it is recommended to use the **Single Five In Five Out** setup.

When the setup procedure has been done for all available engines - or for at least all the engines which are required in the current project - the necessary input- and output ports are ready to be used in the general patch page. (They are not greyed out anymore).

Note : The engine setup is the base setup on which all later selected effects are loaded. So changing the engine setup after effects have already been worked with will reset all effects and they will need to be reloaded again! There is a warning window which informs about the consequences that the changing of the engine setup will have :

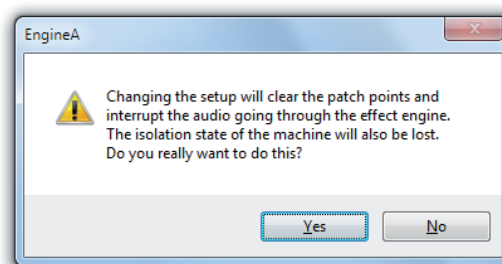

Note : Also the state of the engine setup is stored in snapshots. This means that the engine setup can be changed by recalling a previously created snapshot.

9.6.2 General patch

On the General Patch Ribbon Tab (**General Patch**), there are additional sources and target categories where the effect input- and output ports can be found.

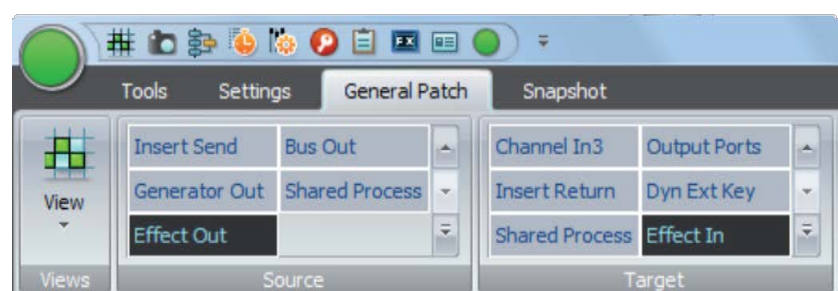

As long as *no* setup is loaded in the Engine Setup window, all effect input- and output ports are greyed out.

Note : When the ports are greyed out, no patch connections can be made !

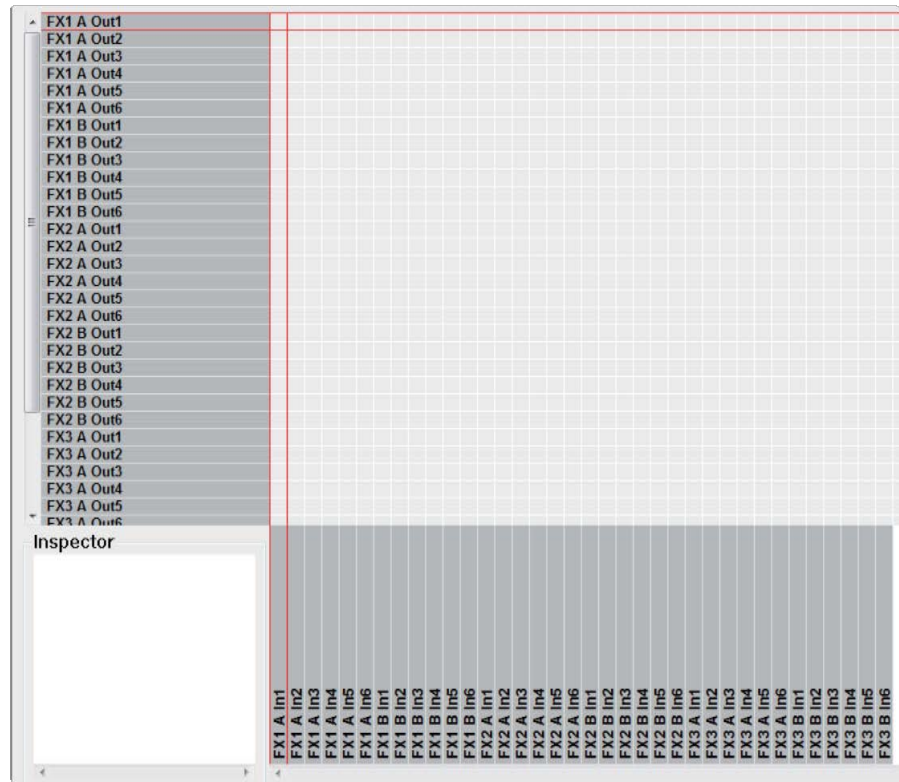

The general patch always shows six input- as well as output ports per engine. Because up to three Vista FX hardware units can be connected, and each hardware unit has two engines, the total of shown patch points is always 36 input- and 36 output ports.

(6 ports x 2 engines x 3 hardware units = 36 patch points).

After one or several setup's have been loaded, the respective input- and output ports become available and are ready to be patched. These ports are then not greyed out anymore.

Dual Stereo setup : For example, it can be seen that when loading a “**Dual Stereo**” setup into **Engine A** of the **FX1** hardware unit, the first four output ports become available for use. They are also labelled according to the **Dual Stereo** setup :

| |
|-----------------|
| FX1 A Out1 M1 L |
| FX1 A Out2 M1 R |
| FX1 A Out3 M2 L |
| FX1 A Out4 M2 R |
| FX1 A Out5 |
| FX1 A Out6 |

Also the input ports become available for patching and are labeled for the **Dual Stereo** setup :

| |
|----------------|
| FX1 A In1 M1 L |
| FX1 A In2 M1 R |
| FX1 A In3 M2 L |
| FX1 A In4 M2 R |
| FX1 A In5 |
| FX1 A In6 |

Quad Mono setup : When loading a **Quad Mono** setup, the ports look accordingly :

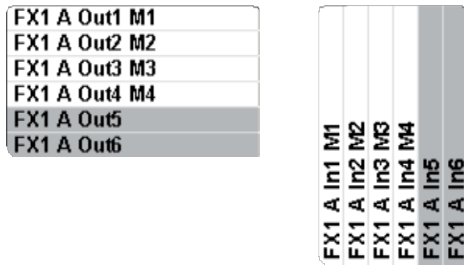

Single Two In Five Out setup : When loading a **Single Two In Five Out** setup, the ports look accordingly :

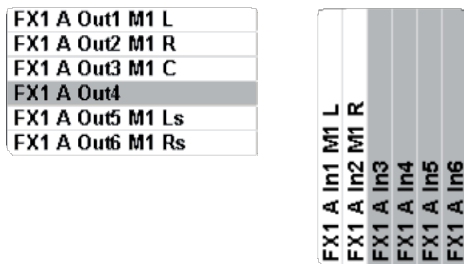

Single Five In Five Out setup : When loading a **Single Five In Five Out** setup, the ports look accordingly :

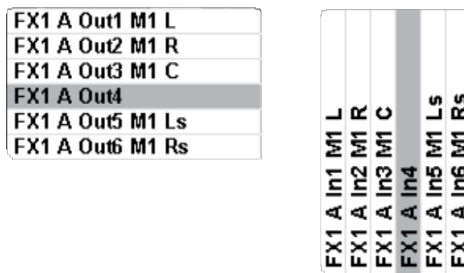

Single Six In Six Out setup : When loading a **Single Six In Six Out** setup, the ports look accordingly :

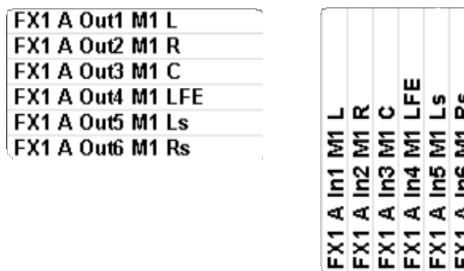

Patch connections now can be made as with other sources and targets. Once connections are made, they will also be indicated in the FX Engine Setup window :

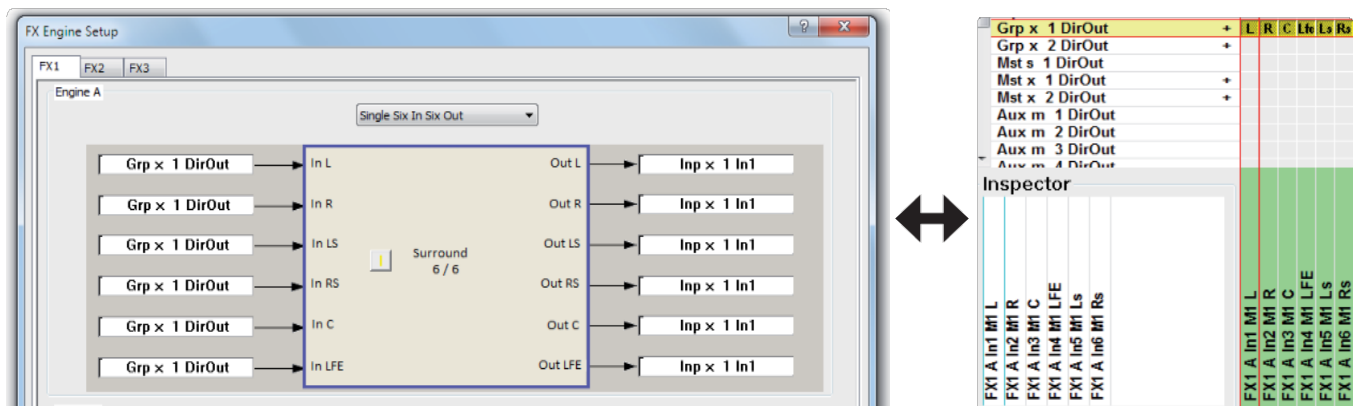

As a shortcut for ‘patching to effect targets’ and ‘from effect sources’, it is also possible to doubleclick into one of the twelve label areas in the setup window. This then navigates directly to the general patch, to the desired target or source.

9.6.3 Create send return effects

To setup the desk for working with a ‘Send-Return’ effect, a few steps of preparation need to be carried out :

1. Patch the Direct Out of the desired Aux master to the effect inputport.



This will change the colour of the Aux send icons as well as the Aux master to blue. This is to indicate that the chosen Aux bus is used as an effect send.



2. Patch the effect out port to the desired return channel (input channel).



This return channel then gets the blue FX icon instead of the panning icon in the Vistonics touch area (the panning can still be done in the channel 'misc' view).

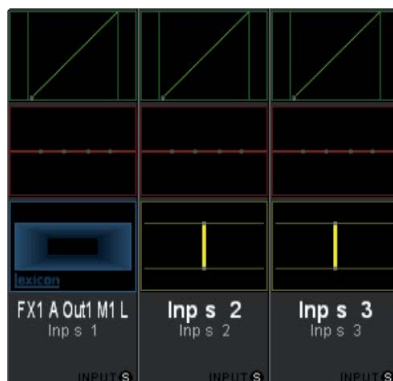

3. Make the desired bus assign for the return channel
4. Operate the FX parameters from the FX icon in the Vistonics toucharea.
5. Use Filters and EQ as well as Dynamics of the return channel to further process the effect sound to taste.

These steps can be repeated for as many 'Send-Return' effects as needed for the current title. It is also a good idea to have such setup already as a part of the generic console setup - e.g. stored in a preset or snapshot.

9.6.4 Create insert effects

To setup the desk for working with an 'Insert' effect, the following steps of preparation need to be carried out :

1. Patch the effect output port and effect input port into the insert path of the desired channel - either on general patch or easier on channel patch page.

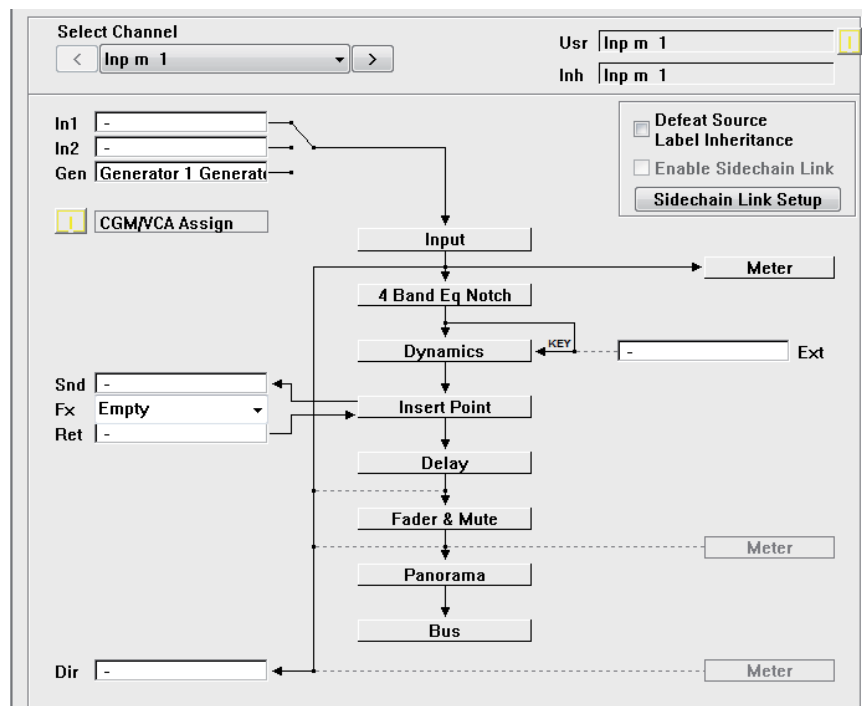

On the channel patch page : only the desired FX block needs to be chosen from the pull-down menu, patching is then done automatically. The pull-down menu shows all FX blocks which are not used yet, and which fit the channel width (mono. stereo, surround) of the channel.

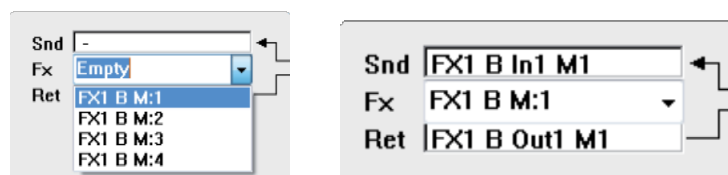

The patching, which is carried out automatically, will then show as follows :

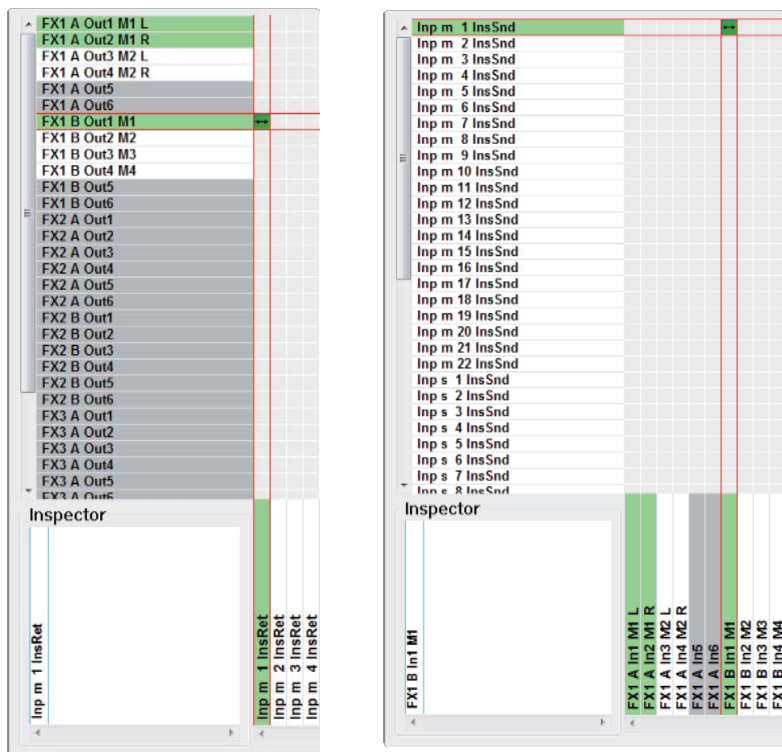

This channel then gets the blue FX icon instead of the panning icon in the Vistonics touch area (the panning can still be done in the channel ‘misc’ view).

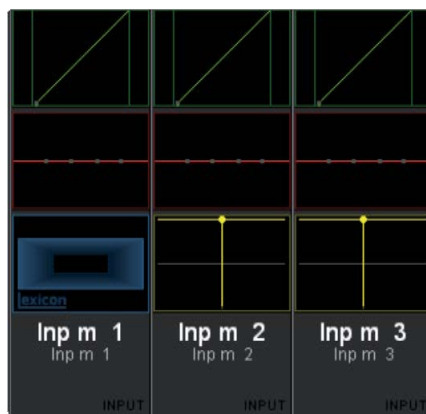

2. Operate the FX parameters from the FX icon in the Vistonics toucharea.
3. Activate the channels **Insert On/Off**.
4. Use the effects wet/dry **Mix** parameter to blend the processed signal to the dry signal to get the desired resulting sound.

9.6.5 Loading effects

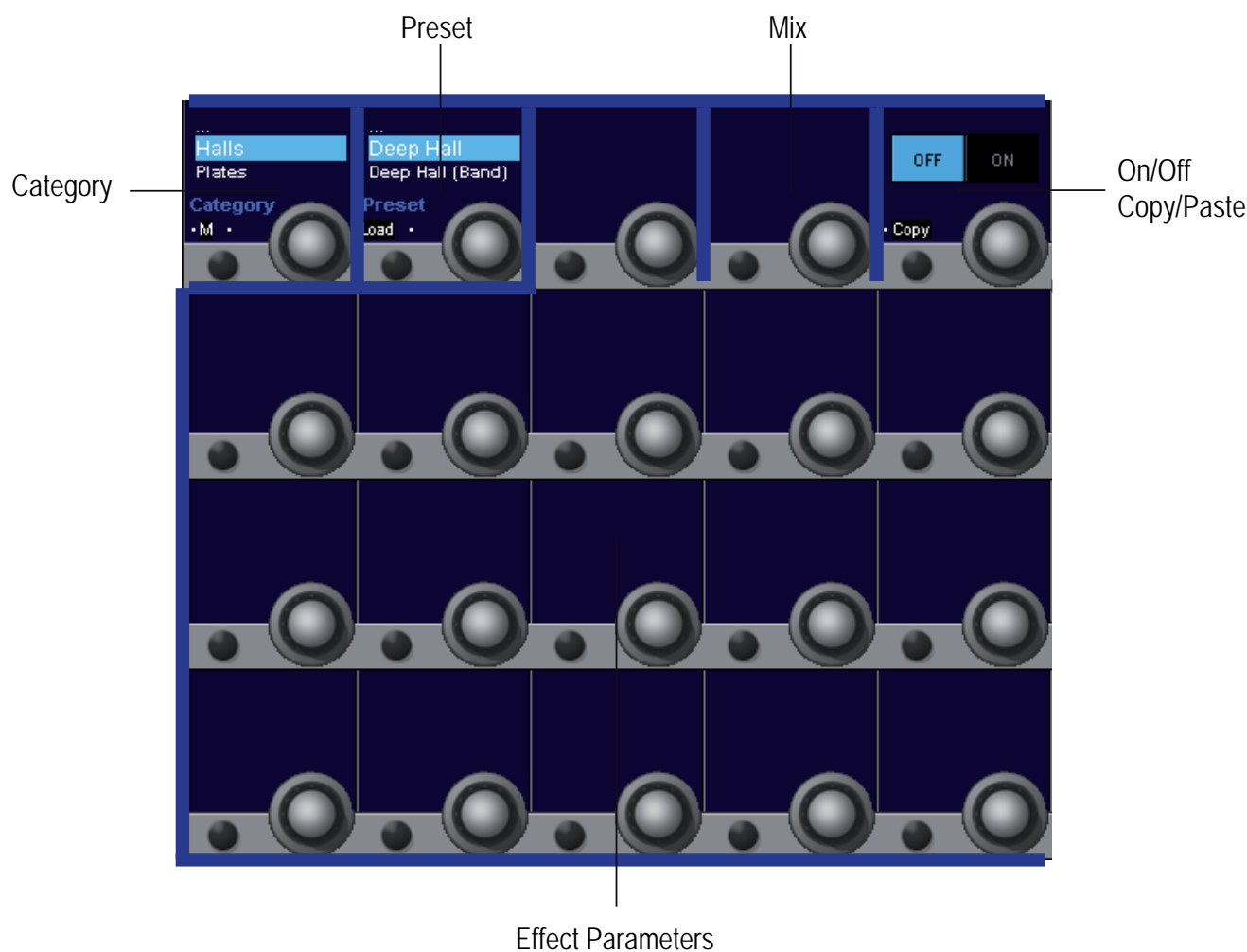

When touching into the FX icon area of the Vistronics, a number of blue coloured Vistronics rotaries and icon areas are opened up. This area is always 5 x 4 Vistronics rotaries wide. It is divided into the following areas :

Category : The Vista FX presets are grouped into categories. Each category has its own set of presets. Category is describing the 'type' of the effect. On all reverb effects, the categories are further divided into small, medium or large size.

S : small

M : medium

L : Large

The size can be toggled-through with the Vistronics button.

Preset : Presets are defined Lexicon factory presets, which can only be loaded. Presets cannot be stored as user presets - as is normally possible with standalone effect units.

When effect parameters are adapted to the users needs - they can be stored within a snapshot. Presets always remain as they originally have been designed by Lexicon. Once any of the presets parameters has been changed , the **Load** button is changed and becomes a **Clear** button. By pressing **Clear**, all parameters are cleared back to the original preset values.

- Mix :** Adjusts the proportion of wet (processed) signal to dry (unprocessed) signal. Ranges from 0% (all dry) to 100% (all wet). With send-return effects, you will leave this at 100% wet, and with insert-effects, the desired dry/wet blend can be created.
- On/Off - Copy/Paste :** Here, the effect processing of the engine is globally switched **On** or **Off**. Please note, that the default state of the processing is **Off** !
The small Vistonics button has the function of a copy/paste button. With the copy/paste button, effect settings can be copied from effect engine to engine - or into the clipboard librar .
- Effect Parameters :** In this area, all effect parameters are displayed and can be controlled from the Vistonics rotaries and buttons.
(Please note that a maximum of 16 parameters can be used. Some of the original Lexicon effects have more than 16 parameters, in this case STUDER has made the choice of the 16 most important parameters - which then can be controlled.)
- Loading a preset : To load a **Preset**, first the effect **Category** has to be chosen. With all reverberation effect categories, also the choice of the space size can be made. This is done with the Vistonics element on the left side.
With the second Vistonics element, the preset can be chosen. The list of presets which are available in the chosen category can be scrolled through with the rotary. Once the desired preset has been found, it can be loaded by pressing the **Load** button.



As soon as a preset is loaded, it's control parameters are shown on the Vistonics area. If the user then scrolls further through the preset list, the parameters disappear again, but they will come back when the preset loaded before (now marked with an asteriks in front of the name *) is brought into the highlighted area :



This is because the loaded preset remains loaded and is running, only until a different preset is loaded by pressing the **Load** button.

The same behaviour applies for the **Category** control.

9.6.6 effect parameters

Please note that per preset, a maximum of 16 parameters can be controlled on the Vistonics user interface. Some of the original Lexicon effects have more than 16 parameters, in this case STUDER has made the choice of the 16 most important parameters - which then can be controlled.

On/Off : Switches the effect processing On and Off.

Mix : Allows to blend the unprocessed signal with the processed effect signal. Range [0 .. 100] %

These two parameters are available for all effect presets.

9.6.6.1 halls, plates and Chambers

For the categories

Halls, Plates and Chambers

the following parameters are available :

Predelay : This is a delay that is added to the diffused signal before it enters the main part of the reverb. For all intents, it may be considered as delay that is added to the reverberated signal. It is used to temporally separate the reverb from the dry signal. Range [0 .. 1000] ms.

Reverb Time : This is the reverb decay time. The range is depending on the Room Size parameter. Range [0.11 .. 210] s.

Reverb Out Frequency : The late reverb signal is filtered by a one pole low-pass. This is the filters cutoff frequency. Range [50 .. 20'000] Hz.

Front Reverb Frequency : The front portion of the late reverb signal is filtered by a one pole low-pass. This is the filters cutoff frequency. Range [50 .. 20'000] Hz. *On surround engines only.*

Back Reverb Frequency : The back portion of the late reverb signal is filtered by a one pole low-pass. This is the filters cutoff frequency. Range [50 .. 20'000] Hz. *On surround engines only.*

Center Reverb Frequency : The center portion of the late reverb signal is filtered by a one pole low-pass. This is the filters cutoff frequency. Range [50 .. 20'000] Hz. *On surround engines only.*

Diffusion : Input diffusion is the first part of processing for any signal entering a reverb. It can be described as a smearing or softening of the signal and is typically used to lessen the impact of strong transients. Range [0 .. 100] %.

Reverb Time HiCut : This parameter, also known as Hicut or RTHC is a low-pass filter in the recirculating part of the reverb. It represents a frequency above which the tail dies away more quickly. In some ways, it represents the opposite end of the scale from BassRT, and may be considered an analog of air absorption. It is also closely tied to the Hi Cut Damping parameter. Range [50 .. 20'000] Hz.

- Bass RT :** This parameter controls bass reverb time. It is closely associated with the Bass Crossover parameter. BassRT applies to signal below the frequency described by Bass Crossover. If BassRT is less than 1.0, then the low frequency part of the reverb tail will be shorter than the midrange part. If BassRT is greater than 1.0, then the low frequency part of the tail is longer. Range [0.25 .. 4] multiplier.
- Tail Width :** The reverb tail (all components of the reverb except for early reflections, etc.) is passed through a simple 2x2 matrix. This provides an encoding of the tail that dramatically changes its spatial characteristics. The tail can be changed to feel narrower (even down to mono) or wider than normal stereo. There are values for the parameter to encode the tail in such a way that it decodes into surround channels.
The parameter operates in the range of 0 to 360 degrees, with an incremental change of 1 degree. The matrix uses Sine/Cosine rules so that power distribution remains constant. This may be acceptable—even highly desirable—but the mix engineer must fully understand the process and its implications.
This is a powerful tool for audio whose release format is two-channel. It is not useful in any other format. Formats include compact disc and radio/television broadcast. Some of these effects are clear and noticeable without any sort of decoder. Many are even more dramatic when a decoder is in place, such as in a home theater. Range [0 .. 360] degrees. *On stereo engines only.*
- Early Level :** This parameter acts as a master control for any early signals going to the output channels. Early signals include echoes, reflections, and the room reflection patterns. Range [Off .. 0.0] dB
- Bass Crossover :** The Bass Crossover parameter is closely tied to the BassRT parameter. It represents the frequency below which BassRT has an effect. Range [50 .. 10'000] Hz
- RtHC Damping :** The damping parameter is closely tied to the RTHC parameter. It controls the strength of the hi frequency absorption and has three values: Light, Normal, and Heavy. The normal value gives filter response identical to previous Lexicon® reverbs. The other values should be self-descriptive. Range [light, normal, heavy]
- Shape :** The Shape parameter is closely tied to the Spread parameter. Shape controls how energy is injected into the reverberator. A low value means that sound enters the reverb at the beginning of the spread window. A high value means that most sound moves into the reverb at the end of the spread window. A value somewhere in the middle means that sound enters the reverb evenly across the spread window. Range [0 .. 64]
- Room Size :** Room Size corresponds roughly to the length of the longest wall of a rectangular room. In a more general sense, it corresponds to the overall dimension of some mythical space. This space has a geometry that causes sound to bounce around. When the room size is small, the “walls” of this space are closer together and the resultant reflection density increases. When the room size is large, that density decreases. The most natural reverbs use room sizes that vary from about 24 meters to 45 meters or so, but there are many useful reverbs that are outside of this range. Range [2.0 .. 80.0] m

Reverb Level : This parameter acts as a master control for reverb signals going to the output channels. Range [Off .. 0.0] dB

Spread : The spread parameter is closely tied to the Shape parameter. Spread is a window of time during which a signal is injected into the reverb. Shape controls just how the signal is injected during this window. Range [0 .. 100] %

Reflection Time Master : Controls all reflection delays in the algorithm. Each reflection delay voice has its nominal delay time adjusted by this percentage. Range [0 .. 100] %

9.6.6.2 Rooms

For the category

Rooms

the following parameters are available :

- Reverb Time :** This is the reverb decay time. The range is depending on the Room Size parameter. Range [0.11 .. 210] s.
- Room Size :** Room Size corresponds roughly to the length of the longest wall of a rectangular room. In a more general sense, it corresponds to the overall dimension of some mythical space. This space has a geometry that causes sound to bounce around. When the room size is small, the “walls” of this space are closer together and the resultant reflection density increases. When the room size is large, that density decreases. The most natural reverbs use room sizes that vary from about 24 meters to 45 meters or so, but there are many useful reverbs that are outside of this range. Range [2.0 .. 80.0] m
- Predelay :** This is a delay that is added to the diffused signal before it enters the main part of the reverb. For all intents, it may be considered as delay that is added to the reverberated signal. It is used to temporally separate the reverb from the dry signal. Range [0 .. 1000] ms.
- Diffusion :** Input diffusion is the first part of processing for any signal entering a reverb. It can be described as a smearing or softening of the signal and is typically used to lessen the impact of strong transients. Range [0 .. 100] %.
- Front Frequency :** The front portion of the late reverb signal is filtered by a one pole low-pass. This is the filters cutoff frequency. Range [50 .. 20'000] Hz. ***On surround engines only.***
- Back Frequency :** The back portion of the late reverb signal is filtered by a one pole low-pass. This is the filters cutoff frequency. Range [50 .. 20'000] Hz. ***On surround engines only.***
- Early Scale :** This parameter is used to modify the overall time of the selected early impulse. It is a multiplier that goes from 0.5x to 2.0x. The actual time of the responses varies from response to response. The Early Scale parameter simply scales that amount of time. It's fair to describe this a “rubber-banding” the impulse response. Range [0.5 .. 2.0] multiplier.
- Early Crossover :** The Early (Bass) Crossover parameter is closely tied to the Early Bass Boost parameter. It represents the frequency below which Early Bass Boost has an effect. Range [50 .. 10'000] Hz. ***On mono and surround engines only.***
- Pattern Category :** This parameter lets you select a specific category from which a room response may be chosen. Changes here have a direct effect on the Pattern Selector parameter. Range [Small, Medium, Large, Exteriors, Odd, Artificial]
- Pattern :** Selects a space available in the selected Category. Range [various spaces]
- Early Level :** This parameter acts as a master control for any early signals going to the output channels. Early signals include echoes, reflections, and the room reflection patterns. Range [Off .. 0.0] dB. ***On mono and stereo engines only.***

- Reverb Level :** This parameter acts as a master control for reverb signals going to the output channels. Range [Off .. 0.0] dB. *On mono and stereo engines only.*
- RtHC Damping :** The damping parameter is closely tied to the RTHC parameter. It controls the strength of the hi frequency absorption and has three values: Light, Normal, and Heavy. The normal value gives filter response identical to previous Lexicon® reverbs. The other values should be self-descriptive. Range [light, normal, heavy]. *On stereo engines only.*
- Early Frequency :** The early reflection signal is filtered by a one pole low-pass. This is the filters cutoff frequency. Range [50 .. 20'000] Hz. *On mono engines only.*
- Early Bass Boost :** This parameter is closely tied to the Early Crossover parameter. It controls the boost (or cut) of signal below that crossover. Range [-12.0 .. +12.0] dB
- Tail Width :** The reverb tail (all components of the reverb except for early reflections, etc.) is passed through a simple 2x2 matrix. This provides an encoding of the tail that dramatically changes its spatial characteristics. The tail can be changed to feel narrower (even down to mono) or wider than normal stereo. There are values for the parameter to encode the tail in such a way that it decodes into surround channels.
The parameter operates in the range of 0 to 360 degrees, with an incremental change of 1 degree. The matrix uses Sine/Cosine rules so that power distribution remains constant. This may be acceptable—even highly desirable—but the mix engineer must fully understand the process and its implications. This is a powerful tool for audio whose release format is two-channel. It is not useful in any other format. Formats include compact disc and radio/television broadcast. Some of these effects are clear and noticeable without any sort of decoder. Many are even more dramatic when a decoder is in place, such as in a home theater. Range [0 .. 360] degrees. *On stereo engines only.*
- Reverse :** Reverses the impulse response of the room. Range [On .. Off]. *On mono and stereo engines only.*

9.6.6.3 Environments

For the category

Environmens

a subset of the **Halls**, **Rooms** and **Delay** parameters are available.

9.6.6.4 Chorus / Flange

For the category

Chorus / Flange

the following parameters are available.

- Delay Level :** Controls all delays in the algorithm. Each voice has its nominal gain value adjusted by this percentage. [0 .. 100] %
- Delay Feedback :** Controls all delays in the algorithm. Each voice has its nominal feedback gain adjusted by this percentage. Range [0 .. 100] %.
- Delay Time :** Controls all delays in the algorithm. Each voice has its nominal delay time adjusted by this percentage. Range [0 .. 100] %
- LFO Rate :** Sets the speed of an LFO. Range [0.01 .. 10.0] Hz
- LFO Waveform Type :** Sets the shape of the wave the LFO will follow. Range [various waveforms]. *On stereo and surround engines only.*
- Voice Delay Wander :** This parameter determines the amount of additional delay that the LFO process can add to a voice's offset. Range [0.0 .. 1000] ms. *On surround engines only.*
- Mst Diffusion :** Input diffusion is the first part of processing for any signal entering a delay. It can be described as a smearing or softening of the signal and is typically used to lessen the impact of strong transients. Range [0 .. 100] %.

9.6.6.5 Delay

For the category

Delay

the first few presets use a subset of the **Halls** parameters, all other presets have the following parameters :

- Delay Time :** Controls all delays in the algorithm. Each voice has its nominal delay time adjusted by this percentage. Range [0 .. 100] %
- Voice Delay :** Delay time of Voice 1. Range [0 .. 9500] ms
- Voice FB :** This parameter determines the feedback level for a particular voice. It is controlled independently of the voice's output level. Range [0.0 INV .. Off .. 0.0] dB
- Delay Level :** Controls all delays in the algorithm. Each voice has its nominal gain value adjusted by this percentage. [0 .. 100] %

- Voice 1 Frequency :** The delay voice output signal is filtered by a one pole low-pass. This is the filters cutoff frequency Range [50 .. 20'000] Hz
- Voice 1 FB :** The feedback signal is filtered by a one pole low-pass. This is the filters cutoff frequency Range [50 .. 20'000] Hz
- Mst Diffusion :** Input diffusion is the first part of processing for any signal entering a delay. It can be described as a smearing or softening of the signal and is typically used to lessen the impact of strong transients. Range [0 .. 100] %.
- FB Diffusion :** Feedback Diffusion is similar to Input Diffusion, except that it is applied to a delayed signal that is being added back into the input. Range [0 .. 100] %.
- LFO Rate :** Sets the speed of an LFO. Range [0.01 .. 10.0] Hz
- Delay Feedback :** Controls all delays in the algorithm. Each voice has its nominal feedback gain adjusted by this percentage. Range [0 .. 100] %.
- Tapping :** Assigns the Tap control to one of the **USR** buttons on the consoles channel strip. Range [No, USR1, USR2]

9.6.6.6 resonance

For the category

Resonance (Resonant Chords)

the following parameters are available.

- Delay Level :** Controls all delays in the algorithm. Each voice has its nominal gain value adjusted by this percentage. [0 .. 100] %
- Delay Feedback :** Controls all delays in the algorithm. Each voice has its nominal feedback gain adjusted by this percentage. Range [0 .. 100] %.
- Delay Time :** Controls all delays in the algorithm. Each voice has its nominal delay time adjusted by this percentage. Range [0 .. 100] %
- Resonance Master :** Controls all voices in the algorithm. Each voice has its nominal resonance adjusted by this percentage. Range [0 .. 100] %
- Resonance Frequency :** This parameter determines at which frequency the delay voice resonates. Range [C0 .. B7] music note. *On mono engines only.*

9.6.6.7 reverse

For the category

Reverse

the parameters of the Room category are available, with one additional parameter :

- Reverb Shelf :** This parameter allows a certain amount of unfiltered audio to be combined with the filtered audio. This effectively lowers the effect of the filter. Another

way of looking at it is that it lessens the normal filter slope of 12 dB per octave. Range [Off .. 0.0] dB. *On mono and stereo engines only.*

9.6.6.8 Pitch Shift

For the category
Pitch Shift
the following parameters are available.

- Pitch Shift :** This parameter determines the amount of positive or negative pitch shift for the shift. Expressed in semitones. Range [-12.0 .. 12.0] smt.
- Pitch Trim :** This parameter detunes the pitch shift established by the Shift Semi or Pitch Shift parameters. Range [-50.0 .. 50.0] cnt
- XFade Time :** This is used to control the crossfade time of the splice. In general a short crossfade is desirable, but more complex material may need longer crossfade times. Range [2.0 .. 15.0] ms
- Lowest Shift Frequency :** This tells the shifter the lowest frequency that it may be required to shift. As a general rule of thumb, this should be set in the higher part of the range in order to preserve detail in the shifted material. It should be lowered if artifacts appear in the low frequencies. Range [20.0 .. 250] Hz
- Smart Shift :** This tells the shifter to use smart (content-based) pitch shift or blind shift. In most cases, 'smart' is the better choice. Range [On .. Off]

9.6.6.9 Pitch Effects

For the category
Pitch Effects
the following parameters are available.

- Delay Time :** Controls all delays in the algorithm. Each voice has its nominal delay time adjusted by this percentage. Range [0 .. 100] %
- Pitch Shift :** This parameter determines the amount of positive or negative pitch shift for the shift. Expressed as a percentage. Range [0 .. 100] %
- Delay Feedback :** Controls all delays in the algorithm. Each voice has its nominal feedback gain adjusted by this percentage. Range [0 .. 100] %.
- Mst Diffusion :** Input diffusion is the first part of processing for any signal entering a delay. It can be described as a smearing or softening of the signal and is typically used to lessen the impact of strong transients. Range [0 .. 100] %. *On stereo and surround engines only.*
- Delay Level :** Controls all delays in the algorithm. Each voice has its nominal gain value adjusted by this percentage. [0 .. 100] %. *On stereo engines only.*
- Voice Frequency :** The delay voice output signal is filtered by a one pole low-pass. This is the filters cutoff frequency Range [50 .. 20'000] Hz. *On stereo and surround*

engines only.

FB Diffusion : Feedback Diffusion is similar to Input Diffusion, except that it is applied to a delayed signal that is being added back into the input. Range [0 .. 100] %.
On surround engines only.

9.6.6.10 tap Control

On the category **Delay**, the presets **Simple Mono Delay (T)** and **Simple Stereo Delay (T)** are also providing an assignable Tap control.

Tapping : Assigns the Tap control to one of the **USR** buttons on the consoles channel strip. Range [No, USR1, USR2]

By choosing **USR1** or **USR2**, the Tap control can be done with either of the two user buttons on the consoles channel strip, above the fader. The button can then be tapped in order to configure the resulting delay time. As an optical feedback, the button is blinking with the configured time interval.

9.6.7 Copy/paste

With the **Copy** button, the current preset, with its current parameter settings is being copied into the clipboard. As now the clipboard library window opens up automatically, the settings can be pasted into the clipboard library.



As an alternative, the settings can also be copied into a channel which is also assigned to an effect. To achieve this, the **Paste** button can be used.



Clipboard Library The clipboard library has been extended by a new tap called **FX**. Here all effect library entries are stored.

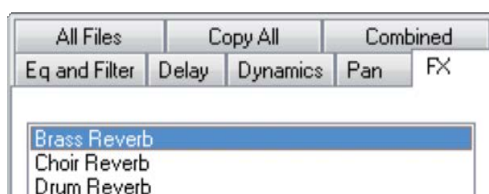

Also a new clipboard library button has been implemented - the copy button next to it can be used to copy library entries into the clipboard, and then into a the desired channel.



Note : Effect settings can only be copied within the same engine setup format (mono, stereo, surround) !
The paste function will only be carried out when the target channel has the same engine format as the source channel, or the setting stored in the clipboard library.
If the format is not matching, the settings are not pasted into the target channel. No error message is displayed - the system will just be ready for a new copy/paste operation.

9.6.8 Snapshot operation

9.6.8.1 Snapshots and Presets

All necessary settings to recreate any use of Vista FX can be stored in snapshots. In more detail, the following data is stored within each snapshot or system preset :

- * the engine setup
- * patching of the effect input- and output ports
- * choice of preset
- * effect parameter settings of the current state

Note : The recalling of a snapshot or a preset can change the Vista FX engine setup if this snapshot had been previously stored with a different engine setup.

In such a case where the engine setup is changed by a snapshot, unsaved effect parameter settings can then be overwritten.

Therefore it is important to keep in mind that the engine setup is of great importance and should be set-up correctly at the start of a session and preferably not be changed anymore.

(Of course - a snapshot recall **undo** operation would bring back the unsaved settings if a snapshot had been recalled by error.)

Important : Manually changing the engine setup when the engine is in use, displays a warning window. When performing the same change via a snapshot recall - *no* warning window is displayed !

9.6.8.2 Static Automation

Global Snapshot filter With the global snapshot filter, effect parameters can be isolated as any other audio parameter in the system. This is done by editing the global snapshot filter, and then touching any of the to be isolated parameter controls. Please note that the isolation of **Category** and **Preset** parameters is always linked.

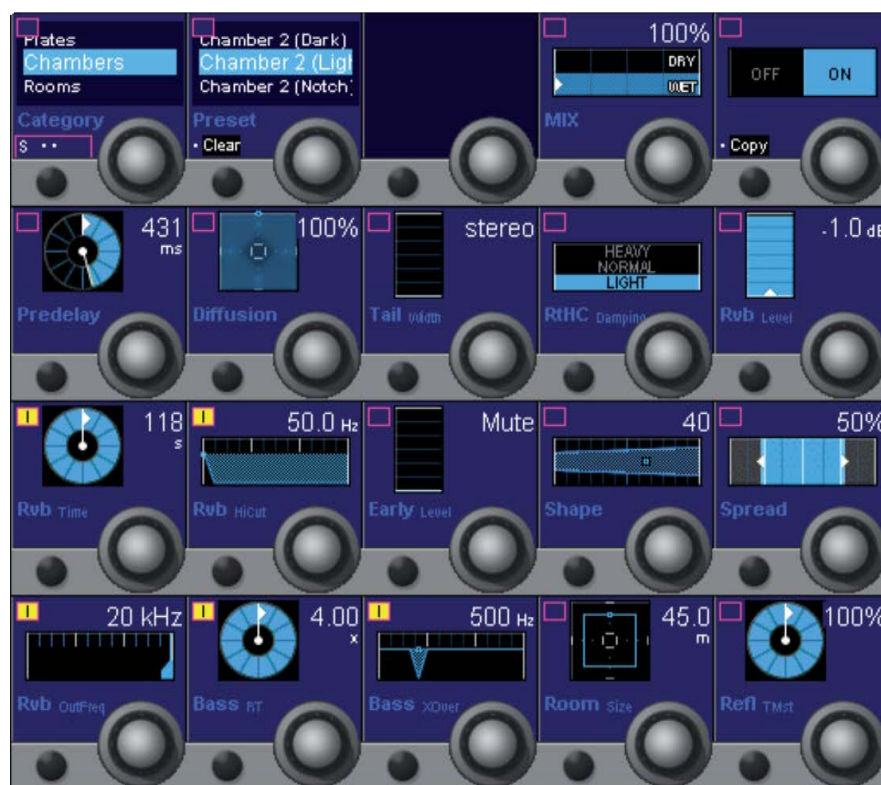

In addition to the effect parameters, also the engine setup - or parts thereof can be isolated. This can be done in the Vista FX engine setup window.

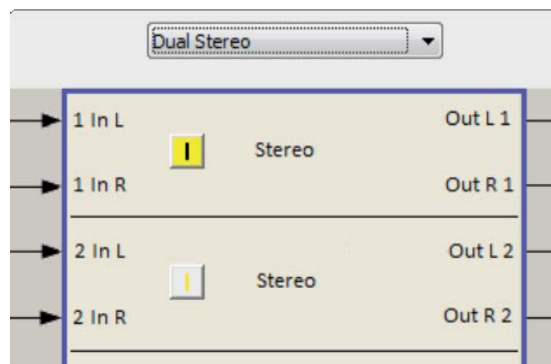

Partial Snapshots Effect parameters can be used in partial snapshots as any other audio parameter in the system. Please refer to [chapter 4.4.4](#) of the Vista operating instructions for more details.

Trim : Please note that as a difference to other audio parameters, effect parameters cannot make use of the **Trim** functionality in the static automation.

CueList crossfades Please note that as a difference to other audio parameters, effect parameters cannot make use of the crossfade functionality in the CueList.

9.6.9 Dynamic automation

Effect parameters can only be used in Static Automation mode. In the Dynamic Automation mode, effect parameters cannot be automated against timecode.

9.6.10 Offline operation

Without having FX connected to the desk, it is possible to configure FX and set its parameters using the Virtual Vista application. If FX boxes have been connected and recognized on the systems there are some entries automatically being written to the D950System.ini file defining the location (audio interfaces) of the connected FX hardware. If there was no FX hardware connected before, the following entries define the desired interfaces.

D950System.ini file :

[LexiconFX]

ConnectedDspCardSlot=

(DSP card slot number where the FX units are connected to. Value: 1 default is empty (0) allowing automatic discovery via D21m).

ConnectedDspCardPort=

(DSP card port number where the FX units are connected to Value: 0 default is port 0).

There must be at least 48 inputs and outputs configured on the port being used for the FX connection.

These settings can also be used to configure FX hardware being connected to the second DSP card port which has no D21m communication and therefore cannot detect the FX boxes automatically.

9.7 preset Overview

This table provides an overview over the number of presets per category and per FX engine setup format.

| Category | Size | Mono | Stereo | Surround | | |
|---------------|--------|------|--------|-----------------|------------------|----------------|
| | | | | Two In Five Out | Five In Five Out | Six In Six Out |
| Halls | Small | 50 | 68 | 86 | 86 | - |
| | Medium | 50 | 60 | 78 | 78 | - |
| | Large | 93 | 105 | 139 | 139 | - |
| Plates | Small | 30 | 30 | 37 | 37 | - |
| | Medium | 35 | 35 | 43 | 43 | - |
| | Large | 35 | 35 | 45 | 45 | - |
| Chambers | Small | 15 | 15 | 21 | 21 | - |
| | Medium | 31 | 31 | 37 | 37 | - |
| | Large | 20 | 30 | 26 | 26 | - |
| Rooms | Small | 56 | 56 | 76 | 76 | - |
| | Medium | 33 | 31 | 59 | 59 | - |
| | Large | 17 | 19 | 29 | 29 | - |
| Environments | - | 12 | 35 | 35 | 35 | - |
| Chorus/Flange | - | 17 | 37 | 34 | 34 | - |
| Delay | - | 15 | 29 | 27 | 27 | - |
| Resonance | - | 13 | 47 | 47 | 47 | - |
| Reverse | - | 21 | 21 | 21 | 21 | - |
| Pitch Shift | - | 4 | 8 | 12 | 12 | 12 |
| Pitch Effects | - | 8 | 25 | 42 | 42 | - |

9.9 specifications

| Supported Sampling Rates | Conditions / Details |
|--------------------------------|---|
| 44.1kHz, 48kHz, 88.2kHz, 96kHz | Clock signal provided from DSP engine via HD-Link connections - Vista FX unit is autolocking to the provided clock. |

| Ambient Conditions | Details | Value |
|-----------------------------|-------------------------|---------------------------|
| Operating Temperature Range | see safety instructions | 5 to 40 °C / 41 to 104 °F |
| Relative Humidity | see safety instructions | 85% |

| Weight | Value |
|---------------|-------------------|
| Vista FX unit | 5.0 kg / 11.0 lbs |

| Redundant Power Supplies | Conditions / Details | Value |
|--------------------------|---|--------------------------------------|
| Input Voltage Range | Power supply auto-ranging, with power factor correction (PFC); EN/UL approved | 100 to 240 V AC ± 10% 50 to 60 Hz |
| Power Consumption | | 25 W |

| Dimensions | Value |
|------------|------------------|
| Width | 48.26 cm / 19 in |
| Height | 2 RU |
| Depth | 39 cm / 15.35 in |