

Studer Vista 1

Digital Mixing System, SW V5.3

1. Introduction, Features
2. General Info, Desk Operation
3. Vistonics® Parameters
4. Graphical Controller (GC) Operation
5. D21m Card/Stagebox Handling
6. DSP Configurations
7. DAW Control
8. RELINK – Resource Linking
9. Vista FX
10. Update Information, Application Notes

Disclaimer

The information in this document has been carefully checked and is believed to be accurate at the time of publication. However, no responsibility is taken by us for inaccuracies, errors, or omissions, nor is any liability assumed for any loss or damage resulting either directly or indirectly from use of the information contained within it.

Prepared and edited by
Studer Professional Audio GmbH
Technical Documentation
Riedthofstrasse 214
CH-8105 Regensdorf - Switzerland
<http://www.studer.ch>

Copyright by Studer Professional Audio GmbH

Order no. 5028620-2

Subject to change

For Your Own Safety and to Avoid Invalidation of the Warranty Please Read This Section Carefully

- Read these instructions
- Keep these instructions
- Heed all warnings
- Follow all instructions
- Do not use this apparatus near water
- Clean only with a dry cloth
- Do not block any ventilation openings. Install in accordance with the manufacturer's instructions
- Do not install near any heat sources such as radiators, heat registers, stoves, or other apparatus (including amplifiers) that produce heat
- Do not defeat the safety purpose of a polarised or grounding type plug. A polarised plug has two blades with one wider than the other. A grounding type plug has two blades and a third grounding prong. The wide blade or the third prong are provided for your safety. If the provided plug does not fit into your outlet, consult an electrician for replacement of the obsolete outlet
- Protect the power cord from being walked on or pinched particularly at plugs, convenience receptacles and the point where they exit from the apparatus
- Only use attachments/accessories specified by the manufacturer
- Use only with the cart, stand, tripod, bracket or table specified by the manufacturer, or sold with the apparatus. When a cart is used, use caution when moving the cart/apparatus combination to avoid injury from tip-over
- Refer all servicing to qualified service personnel. Servicing is required when the apparatus has been damaged in any way, such as power-supply cord or plug is damaged, liquid has been spilled or objects fallen into the apparatus, the apparatus has been exposed to rain or moisture, does not operate normally, or has been dropped

Note: It is recommended that all maintenance and service on the product should be carried out by Studer or its authorised agents. Studer cannot accept any liability whatsoever for any loss or damage caused by service, maintenance or repair by unauthorised personnel

- **WARNING:** To reduce the risk of fire or electric shock, do not expose this apparatus to rain or moisture. Do not expose the apparatus to dripping or splashing and do not place objects filled with liquids, such as vases, on the apparatus
- No naked flame sources, such as lighted candles, should be placed on the apparatus
- Ventilation should not be impeded by covering the ventilation openings with items such as newspapers, table cloths, curtains etc.

Warning: Do not use this apparatus in very dusty atmospheres, or in atmospheres containing flammable gases or chemicals

- **THIS APPARATUS MUST BE EARTHED.** Under no circumstances should the safety earth be disconnected from the mains lead

- **The mains supply disconnect device is the mains plug. It must remain accessible so as to be readily operable when the apparatus is in use**
- **If any part of the mains cord set is damaged, the complete cord set should be replaced. The following information is for reference only. The wires in the mains lead are coloured in accordance with the following code:**
 - **Protective Earth (Ground): Green/Yellow (US: Green or Green/Yellow)**
 - **Neutral: Blue (US: White)**
 - **Live (Hot): Brown (US: Black)**

As the colours of the wires in the mains lead may not correspond with the coloured markings identifying the terminals in your plug, proceed as follows:

- **The wire which is coloured Green and Yellow must be connected to the terminal in the plug which is marked with the letter E or by the earth symbol**
- **The wire which is coloured Blue must be connected to the terminal in the plug which is marked with the letter N**
- **The wire which is coloured Brown must be connected to the terminal in the plug which is marked with the letter L**

Ensure that these colour codes are followed carefully in the event of the plug being changed

- **This unit is capable of operating over a range of mains voltages, as marked on the rear panel**

Note: This equipment has been tested and found to comply with the limits for a Class A digital device, pursuant to Part 15 of the FCC Rules. These limits are designed to provide reasonable protection against harmful interference when the equipment is operated in a commercial environment. This equipment generates, uses and can radiate radio frequency energy and, if not installed and used in accordance with the instruction manual, may cause harmful interference to radio communications. Operation of this equipment in a residential area is likely to cause harmful interference in which case the user will be required to correct the interference at his own expense.

This Class A digital apparatus meets the requirements of the Canadian Interference-Causing Equipment Regulations.

Cet appareil numérique de la Classe A respecte toutes les exigences du Règlement sur le matériel brouilleur du Canada.

Working Safely With Sound

Although your new console will not make any noise until you feed it signals, it has the capability to produce sounds that, when monitored through a monitor system or headphones can damage hearing over time. The table below is taken from the Occupational Safety & Health Administration directive on occupational noise exposure (1926.52):

Permissible Noise Exposure:



Duration per day [h]	Sound level [dBA, slow response]
8	90
6	92
4	95
3	97
2	100
1.5	102
1	105
0.5	110
<0.25	115

Conforming to this directive will minimise the risk of hearing damage caused by long listening periods. A simple rule to follow is: The longer you listen, the lower the average volume should be. Please take care when working with your audio system – if you are manipulating controls which you don't understand (which we all do when we are learning), make sure your monitoring level is turned down. *Remember that your ears are the most important tool of your trade. Look after them, and they will look after you. Most importantly: Don't be afraid to experiment to find out how each parameter affects the sound; this will extend your creativity and help you to get the best results.*

A1 Safety Symbol Guide

For your own safety and to avoid invalidation of the warranty, all text marked with these symbols should be read carefully.



To reduce the risk of electric shock, do not remove covers. No user-serviceable parts inside. Refer servicing to qualified service personnel (i.e., persons having appropriate technical training and experience necessary to be aware of hazards to which they are exposed in performing a repair action, and of measures to minimize the danger of themselves).



The lightning flash with arrowhead symbol is intended to alert the user to the presence of un-insulated 'dangerous voltage' within the product's enclosure that may be of sufficient magnitude to constitute a risk of electric shock to persons.



The exclamation mark within an equilateral triangle is intended to alert the user to the presence of important operating and maintenance (servicing) instructions in the literature accompanying the appliance.



Headphones safety warnings contain important information and useful tips on headphone outputs and monitoring levels.



Assemblies or sub-assemblies of this product can contain opto-electronic devices. As long as these devices comply with Class I of laser or LED products according to EN 60825-1:1994, they will not be expressly marked on the product. If a special design should be covered by a higher class of this standard, the device concerned will be marked directly on the assembly or sub-assembly in accordance with the above standard.



A2 First Aid

In Case of Electric Shock:

Separate the person as quickly as possible from the electric power source:

- By switching the equipment off,
- By unplugging or disconnecting the mains cable, or
- By pushing the person away from the power source, using dry insulating material (such as wood or plastic).
- After having suffered an electric shock, *always* consult a doctor.

Warning!



Do not touch the person or his clothing before the power is turned off, otherwise you stand the risk of suffering an electric shock as well!

If the Person is Unconscious:

- Lay the person down
- Turn him to one side
- Check the pulse
- Reanimate the person if respiration is poor
- *Call for a doctor immediately.*

B General Installation Instructions

Please consider besides these general instructions also any product-specific instructions in the 'Installation' chapter of this manual.

B1 Unpacking

Check the equipment for any transport damage. If the unit is mechanically damaged, if liquids have been spilled or if objects have fallen into the unit, *it must not be connected to the AC power outlet, or it must be immediately disconnected by unplugging the power cable*. Repair must only be performed by trained personnel in accordance with the applicable regulations.

B2 Installation Site

Install the unit in a place where the following conditions are met:

- The temperature and the relative humidity of the environment must be within the specified limits during operation of the unit. *Relevant values are the ones at the air inlets of the unit* (refer to Appendix 1).
- Condensation must be avoided. If the unit is installed in a location with large variation of ambient temperature (e.g. in an OB-van), appropriate precautions must be taken *before and after operation* (refer to Appendix 1).
- Unobstructed air flow is essential for proper operation. Air vents of the unit are a functional part of the design and must not be blocked in any way during operation (e.g. by objects placed upon them, placement of the unit on a soft surface, or installation of the unit within a rack or piece of furniture).
- The unit must not be heated up by external sources of heat radiation (sunlight, spotlights).

B3 Earthing and Power Supply

Earthing of units with mains supply (class I equipment) is performed via the protective earth (PE) conductor integrated in the mains cable. Units with battery operation (< 60 V, class III equipment) must be earthed separately. Earthing the unit is one of the measures for protection against electrical shock hazard (dangerous body currents). Hazardous voltage may not only be caused by a defective power supply insulation, but may also be introduced by the connected audio or control cables.

If the unit is installed with one or several external connections, its earthing must be provided during operation as well as while the unit is not operated. If the earthing connection can be interrupted, for example, by unplugging the mains plug of an external power supply unit, an additional, permanent earthing connection must be installed using the provided earth terminal.

Avoid ground loops (hum loops) by keeping the loop surface as small as possible (by consequently guiding the earth conductors in a narrow, parallel way), and reduce the noise current flowing through the loop by inserting an additional impedance (common-mode choke).

Class I Equipment (Mains Operation)

Should the equipment be delivered without a matching mains cable, the latter has to be prepared by a trained person using the attached female plug (IEC 320 / C13 or IEC 320 / C19) with respect to the applicable regulations in your country.

Before connecting the equipment to the AC power outlet, check that the local line voltage matches the equipment rating (voltage, frequency) within the admissible tolerance. The equipment fuses must be rated in accordance with the specifications on the equipment.

Equipment supplied with a 3-pole appliance inlet (protection conforming to class I equipment) *must* be connected to a 3-pole AC power outlet in such a way that the equipment cabinet is connected to the protective earth.

For information on mains cable strain relief, please refer to Appendix 2.

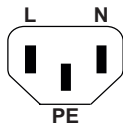
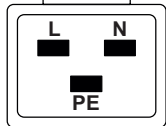
Female Plugs (IEC320), Front-Side View:					
 IEC 320 / C13			 IEC 320 / C19		
European Standard (CENELEC)		North American Standard (NAS)			
Brown	L (Live)	Black			
Blue	N (Neutral)	White			
Green/Yellow	PE (Protective Earth)	Green (or Green/Yellow)			

Class III Equipment (Battery Operation up to 60 V_{DC})

Equipment of this protection class must be earthed using the provided earth terminal if one or more external signals are connected to the unit (see explanation at the beginning of this paragraph).

B4 Electromagnetic Compatibility (EMC)

The unit conforms to the protection requirements relevant to electromagnetic phenomena that are listed in guidelines 89/336/EC and FCC, part 15.

- The electromagnetic interference generated by the unit is limited in such a way that other equipment and systems can be operated normally.
- The unit is adequately protected against electromagnetic interference so that it can operate properly.

The unit has been tested and conforms to the EMC standards of the specified electromagnetic environment, as listed in the following declaration. The limits of these standards ensure protection of the environment and corresponding noise immunity of the equipment with appropriate probability. However, a professional installation and integration within the system are imperative prerequisites for operation without EMC problems.

For this purpose, the following measures must be followed:

- Install the equipment in accordance with the operating instructions. Use the supplied accessories.
- In the system and in the vicinity where the equipment is installed, use only components (systems, equipment) that also fulfill the EMC standards for the given environment.

- Use a system grounding concept that satisfies the safety requirements (class I equipment must be connected with a protective ground conductor) and that also takes into consideration the EMC requirements. When deciding between radial, surface, or combined grounding, the advantages and disadvantages should be carefully evaluated in each case.
- Use shielded cables where shielding is specified. The connection of the shield to the corresponding connector terminal or housing should have a large surface and be corrosion-proof. Please note that a cable shield connected only single-ended can act as a transmitting or receiving antenna within the corresponding frequency range.
- Avoid ground loops or reduce their adverse effects by keeping the loop surface as small as possible, and reduce the noise current flowing through the loop by inserting an additional impedance (e.g. common-mode choke).
- Reduce electrostatic discharge (ESD) of persons by installing an appropriate floor covering (e.g. a carpet with permanent electrostatic filaments) and by keeping the relative humidity above 30%. Further measures (e.g. conducting floor) are usually unnecessary and only effective if used together with corresponding personal equipment.
- When using equipment with touch-sensitive operator controls, please take care that the surrounding building structure allows for sufficient capacitive coupling of the operator. This coupling can be improved by an additional, conducting surface in the operator's area, connected to the equipment housing (e.g. metal foil underneath the floor covering, carpet with conductive backing).

C Maintenance

All air vents and openings for operating elements (faders, rotary knobs) must be checked on a regular basis, and cleaned in case of dust accumulation. For cleaning, a soft paint-brush or a vacuum cleaner is recommended. Cleaning the surfaces of the unit is performed with a soft, dry cloth or a soft brush.

Persistent contamination can be treated with a cloth that is *slightly* humidified with a mild cleaning solution, such as dishwashing detergent.

For cleaning display windows, commercially available computer/TV screen cleaners are suited. Use only a *slightly* damp (never wet) cloth.

Never use any solvents for cleaning the exterior of the unit! Liquids must never be sprayed or poured on directly!

For equipment-specific maintenance information please refer to the corresponding chapter in the operating and service manuals.

D Electrostatic Discharge during Maintenance and Repair

Caution:



Observe the precautions for handling devices sensitive to electrostatic discharge!

Many semiconductor components are sensitive to electrostatic discharge (ESD). The lifespan of assemblies containing such components can be drastically reduced by improper handling during maintenance and repair. Please observe the following rules when handling ESD sensitive components:

- ESD sensitive components should only be stored and transported in the packing material specifically provided for this purpose.

- *When performing a repair by replacing complete assemblies, the removed assembly must be sent back to the supplier in the same packing material in which the replacement assembly was shipped. If this should not be the case, any claim for a possible refund will be null and void.*
- Unpacked ESD sensitive components should only be handled in ESD protected areas (EPA, e.g. area for field service, repair or service bench) and only be touched by persons wearing a wristlet connected to the ground potential of the repair or service bench by a series resistor. The equipment to be repaired or serviced as well as all tools and electrically semi-conducting work, storage, and floor mats should also be connected to this ground potential.
- The terminals of ESD sensitive components must not come in uncontrolled contact with electrostatically chargeable or metallic surfaces (voltage puncture, discharge shock hazard).
- To prevent the components from undefined transient stress and possible damage due to inadmissible voltages or compensation currents, electrical connections should only be established or separated when the equipment is switched off and after any capacitor charges have decayed.

E Repair

By removing housing parts or shields, energized parts may be exposed. For this reason the following precautions must be observed:

- Maintenance may only be performed by trained personnel in accordance with the applicable regulations.
- The equipment must be switched off and disconnected from the AC power outlet before any housing parts are removed.
- Even if the equipment is disconnected from the power outlet, parts with hazardous charges (e.g. capacitors, picture tubes) must not be touched until they have been properly discharged. Do not touch hot components (power semiconductors, heat sinks, etc.) before they have cooled off.
- If maintenance is performed on a unit that is opened while being switched on, no un-insulated circuit components and metallic semiconductor housings must be touched, neither with bare hands nor with un-insulated tools.

Certain components pose additional hazards:

- *Explosion hazard* from lithium batteries, electrolytic capacitors and power semiconductors (Observe the component's polarity. Do not short battery terminals. Replace batteries only by the same type).
- *Implosion hazard* from evacuated display units.
- *Radiation hazard* from laser units (non-ionizing), picture tubes (ionizing).
- *Caustic effect* of display units (LCD) and components containing liquid electrolyte.

Such components should only be handled by trained personnel who are properly protected (e.g. protection glasses, gloves).

E1 SMD Components

Studer has no commercially available SMD components in stock for service purposes. For repair, the corresponding devices have to be purchased locally. The specifications of special components can be found in the service manual. SMD components should only be replaced by skilled specialists using appropriate tools. No warranty claims will be accepted for circuit boards that have been damaged. Proper and improper SMD soldering joints are illustrated below.

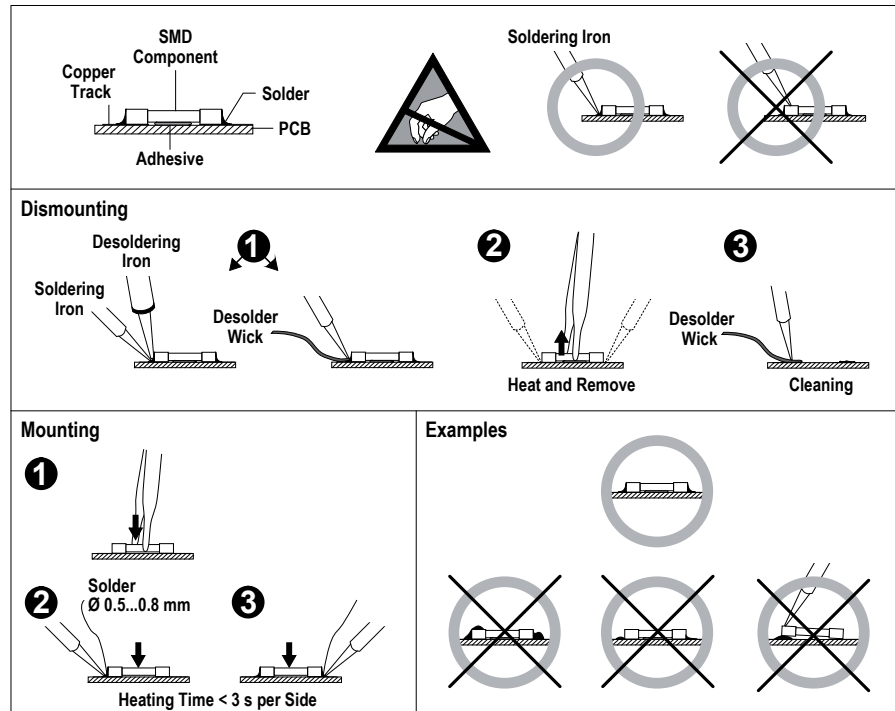

F Disposal

Packing Materials

The packing materials have been selected with environmental and disposal issues in mind. All packing material can be recycled. Recycling packing saves raw materials and reduces the volume of waste. If you need to dispose of the transport packing materials, please try to use recyclable means.

Used Equipment

Used equipment contains valuable raw materials as well as materials that must be disposed of professionally. Please return your used equipment via an authorized specialist dealer or via the public waste disposal system, ensuring any material that can be recycled is. Please take care that your used equipment cannot be abused. To avoid abuse, delete sensitive data from any data storage media. After having disconnected your used equipment from the mains supply, make sure that the mains connector and the mains cable are made useless.

G Declarations of Conformity

G1 Class A Equipment - FCC Notice

This equipment has been tested and found to comply with the limits for a Class A digital device, pursuant to Part 15 of the FCC Rules. These limits are designed to provide a reasonable protection against harmful interference when the equipment is operated in a commercial environment. This equipment generates, uses, and can radiate radio frequency energy and, if not installed and used in accordance with the instruction manual, may cause harmful interference to radio communications. Operation of this equipment in a residential area is likely to cause harmful interference, in which case the user will be required to correct the interference at his own expense.

This Class A digital apparatus meets the requirements of the Canadian Interference-Causing Equipment Regulations.

Cet appareil numérique de la Classe A respecte toutes les exigences du Règlement sur le matériel brouilleur du Canada.

Caution: Any changes or modifications not expressly approved by the manufacturer could void the user's authority to operate the equipment. Also refer to relevant information in this manual.

G2 CE Declaration of Conformity

We,
**Studer Professional Audio GmbH,
CH-8105 Regensdorf,**
declare under our sole responsibility that the product
**Studer Vista 1, Digital Mixing System
(starting with serial no. 1001),**
to which this declaration relates, according to following regulations of EU directives and amendments

- Low Voltage (LVD):
73/23/EEC + 93/68/EEC
 - Electromagnetic Compatibility (EMC):
89/336/EEC + 92/31/EEC + 93/68/EEC
- is in conformity with the following standards or normative documents:
- Safety:
EN 60065:2002 and EN 60950:2001 (Class I equipment)
 - Safety of laser products:
EN 60825-1:1994 + A11 + A2, EN 60825-2:2000
 - EMC:
EN 55103-1/-2:1996, electromagnetic environments E2 and E4.

Regensdorf, May 21, 2008



B. Hochstrasser, General Manager



M. Lienert, Manager R&D

Appendix 1: Air Temperature and Humidity

General

Normal operation of the unit or system is warranted under the ambient conditions defined by *EN 60721-3-3, set IE32, value 3K3*.

This standard consists of an extensive catalogue of parameters, the most important of which are: ambient temperature +5...+40 °C, relative humidity 5...85% (i.e., no formation of condensation or ice); absolute humidity 1...25 g/m³; rate of temperature change < 0.5 °C/min. These parameters are dealt with in the following paragraphs.

Under these conditions the unit or system starts and works without any problem. Beyond these specifications, possible problems are described below.

Ambient Temperature

Units and systems by Studer are generally designed for an ambient temperature range (i.e. temperature of the incoming air) of +5 °C to +40 °C. When rack mounting the units, the intended air flow and herewith adequate cooling must be provided. The following facts must be considered:

- The admissible ambient temperature range for operation of the semiconductor components is 0 °C to +70 °C (commercial temperature range for operation).
- The air flow through the installation must provide that the outgoing air is always cooler than 70 °C.
- Average heat increase of the cooling air shall be about 20 K, allowing for an additional maximum 10 K increase at the hot components.
- In order to dissipate 1 kW with this admissible average heat increase, an air flow of 2.65 m³/min is required.

Example: A rack dissipating $P = 800 \text{ W}$ requires an air flow of $0.8 * 2.65 \text{ m}^3/\text{min}$ which corresponds to $2.12 \text{ m}^3/\text{min}$.

- If the cooling function of the installation must be monitored (e.g. for fan failure or illumination with spot lamps), the outgoing air temperature must be measured directly above the modules at several places within the rack. The trigger temperature of the sensors should be 65 °C to 70 °C.

Frost and Dew

The unsealed system parts (connector areas and semiconductor pins) allow for a minute formation of ice or frost. However, formation of dew visible to the naked eye will already lead to malfunctions. In practice, reliable operation can be expected in a temperature range above -15 °C, if the following general rule is considered for putting the cold system into operation:

If the air within the system is cooled down, the relative humidity rises. If it reaches 100%, condensation will arise, usually in the boundary layer between the air and a cooler surface, together with formation of ice or dew at sensitive areas of the system (contacts, IC pins, etc.). Once internal condensation occurs, trouble-free operation cannot be guaranteed, independent of temperature.

Before putting into operation, the system must be checked for internal formation of condensation or ice. Only with a minute formation of ice, direct

evaporation (sublimation) may be expected; otherwise the system must be heated and dried while switched off.

A system without visible internal formation of ice or condensation should be heated up with its own heat dissipation, as homogeneously (and subsequently as slow) as possible; the ambient temperature should then always be lower than the one of the outgoing air.

If it is absolutely necessary to operate the cold system immediately within warm ambient air, this air must be dehydrated. In such a case, the absolute humidity must be so low that the relative humidity, related to the coldest system surface, always remains below 100%.

Ensure that the enclosed air is as dry as possible when powering off (i.e. before switching off in winter, aerate the room with cold, dry air, and remove humid objects such as clothes from the room).

These relationships are visible from the following climatogram. For a controlled procedure, thermometer and hygrometer as well as a thermometer within the system will be required.

Example 1: An OB-van having an internal temperature of 20 °C and a relative humidity of 40% is switched off in the evening. If the temperature falls below +5 °C, the relative humidity will rise to 100% (7 g/m³); dew or ice will be forming.

Example 2: An OB-van is heated up in the morning with air of 20 °C and a relative humidity of 40%. On all parts being cooler than +5 °C, dew or ice will be forming.

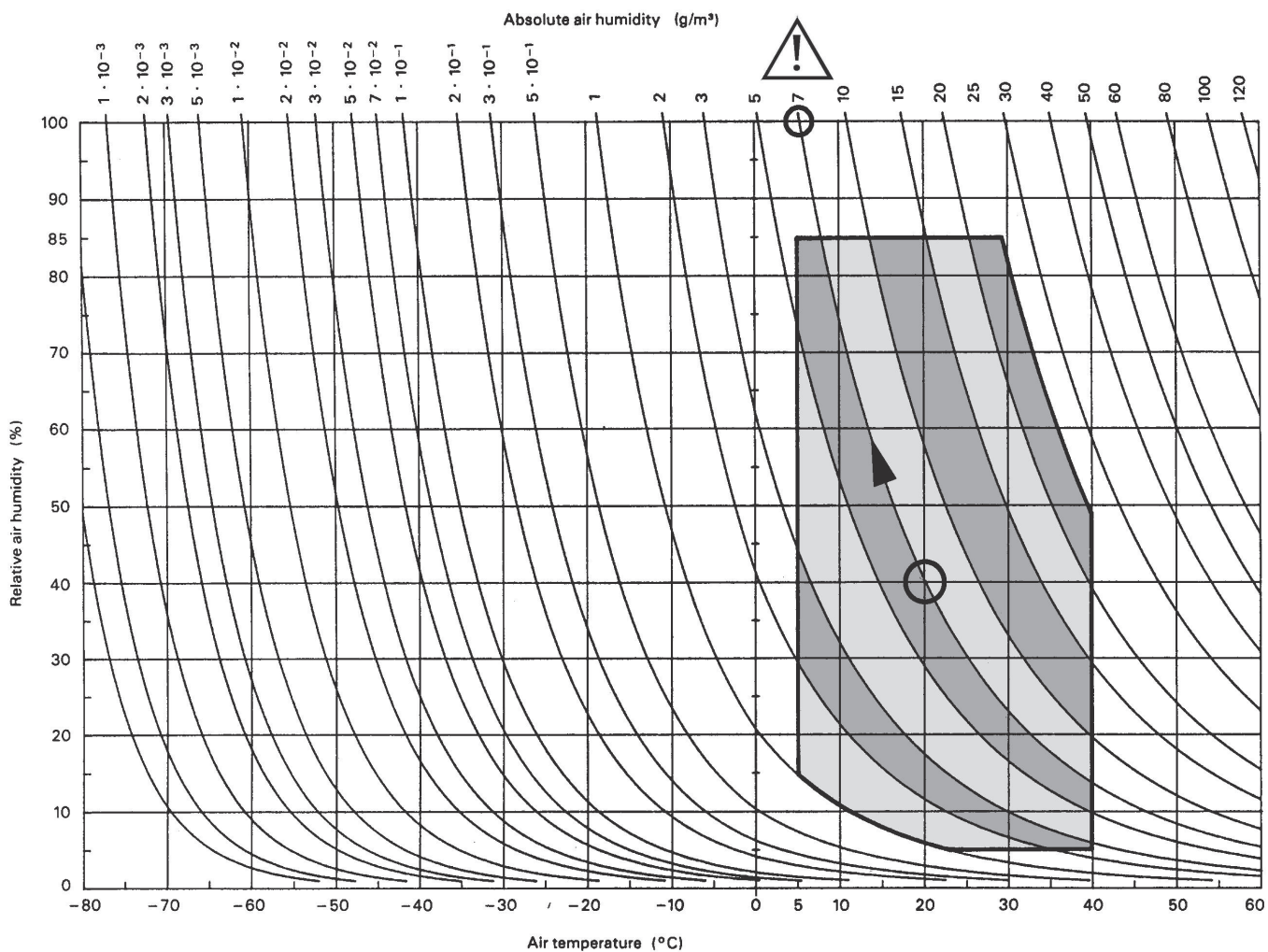

Appendix 2: Mains Connector Strain Relief

For anchoring connectors without a mechanical lock (e.g. IEC mains connectors), we recommend the arrangement below:

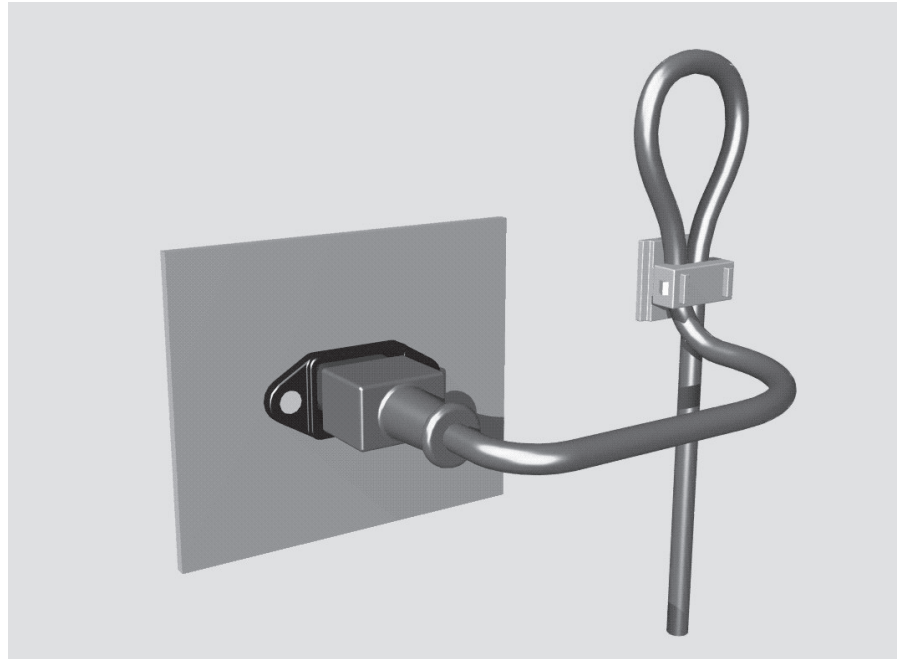

- Procedure:** The cable clamp shipped with your unit is auto-adhesive. For mounting please follow the rules below:
- The surface to be adhered to must be clean, dry, and free from grease, oil, or other contaminants. Recommended application temperature range is +20 °C to +40 °C.
 - Remove the plastic protective backing from the rear side of the clamp and apply it firmly to the surface at the desired position. Allow as much time as possible for curing. The bond continues to develop for as long as 24 hours.
 - For improved stability, the clamp should be fixed with a screw. For this purpose, a self-tapping screw and an M4 bolt and nut are included.
 - Place the cable into the clamp as shown in the illustration above and firmly press down the internal top cover until the cable is fixed.

Appendix 3: Software License

Use of the software is subject to the Studer Professional Audio Software License Agreement set forth below. Using the software indicates your acceptance of this license agreement. If you do not accept these license terms, you are not authorized to use this software.

Under the condition and within the scope of the following Terms and Conditions, Studer Professional Audio GmbH (hereinafter ‘Studer’) grants the right to use programs developed by Studer as well as those of third parties which have been installed by Studer on or within its products. References to the license programs shall be references to the newest release of a license program installed at the Customer’s site.

Programs Covered by the Agreement

License Programs of Studer The following Terms and Conditions grant the right to use all programs of Studer that are part of the System and/or its options at the time of its delivery to the Customer, as well as the installation software on the original data disk and the accompanying documentation (‘License Material’). In this Agreement the word ‘Programs’ shall have the meaning of programs and data written in machine code.

Using the software indicates your acceptance of this license agreement. If you do not accept these license terms, you are not authorized to use this software.

Programs of Third Parties Programs of third parties are all programs which constitute part of the System and/or its options at the time of delivery to the Customer but have not been developed by Studer. The following conditions are applicable to programs of third parties:

- The right to use third parties’ programs is governed by the License Agreement attached hereto (if applicable), which is an integral part of this Agreement. The Customer shall sign any and all License Agreements for all further programs of third parties installed on the system. The Customer shall be deemed to have received all License Agreements upon delivery of the system and/or its options.
- Studer shall accept no responsibility or liability for, and gives no warranties (express or implied) as to the programs of third parties. The Customer waives any and all claims versus Studer for any consequential damages, which might occur due to defects of these programs.

Right of Use

Principle Studer grants the Customer the non-exclusive right to use the License Material in one copy on the system and/or its options as laid down by the Sales Agreement concluded between the parties and all Terms and Conditions which shall be deemed to form and be read and construed as part of the Sales Agreement. This right is assignable according to the ‘Assignability’ paragraph hereinafter.

Customized Configurations The Customer is not entitled to alter or develop further the License Material except within the expressly permitted configuration possibilities given by the software installed on the system or elsewhere. All altered programs, including but not limited to the products altered within the permitted configuration possibilities, are covered by this License Agreement.

Reverse Engineering Reverse engineering is only permitted with the express consent of Studer. The consent of Studer can be obtained but is not limited to the case in which the interface software can not be provided by Studer. In any case Studer has to be informed immediately upon complete or partial reverse engineering.

Copying the License Material The Customer is entitled to make one copy of all or parts of the License Material as is necessary for the use according to this Agreement, namely for backup purposes. The Customer shall apply the copyright of Studer found on the License Material onto all copies made by him. Records shall be kept by the Customer regarding the amount of copies made and their place of keeping. The responsibility for the original program and all copies made lies with the Customer. Studer is entitled to check these records on first request. Copies not needed anymore have to be destroyed immediately.

Disclosure of License Material The License Material is a business secret of Studer. The Customer shall not hand out or in any way give access to parts of or the complete License Material to third parties nor to publish any part of the License Material without prior written consent of Studer. The Customer shall protect the License Material and any copies made according to the paragraph above by appropriate defense measures against unauthorized access. This obligation of non-disclosure is a perpetual obligation.

Third parties are entitled to have access to the License Material if they use the License Material at the Customer's site in compliance with this Agreement. Under no circumstance are third parties entitled to have access to the installation software on the original data media. The Customer shall safeguard the original data media accordingly.

Assignability The rights granted to the Customer according to this License Agreement shall only be assignable to a third party together with the transfer of the system and/or its options and after the prior written consent of Studer.

Rights to License Material

With the exception of the right of use granted by this License Agreement all proprietary rights to the License Material, especially the ownership and the intellectual property rights (such as but not limited to patents and copyright) remain with Studer even if alterations, customized changes or amendments have been made to the License Material.

Studer's proprietary rights are acknowledged by the Customer. The Customer shall undertake no infringements and make no claims of any patent, registered design, copyright, trade mark or trade name, or other intellectual property right.

Warranty, Disclaimer, and Liability

For all issues not covered herewithin, refer to the 'General Terms and Conditions of Sales and Delivery' being part of the sales contract.

CHAPTER 1

1	Introduction.....	3
1.1	Operating Features.....	3
1.1.1	Vistonics®	4
1.1.2	Momentary/Latching Keys ⊕	7
1.1.3	Ganging.....	8
1.1.4	Copy/Paste.....	9
1.1.5	Scrolling.....	10
1.1.6	FaderGlow®	11
1.1.7	TFT Level Meters (Option for 32 fader Vista 1).....	12
1.2	The Graphical Controller (GC).....	14
1.2.1	GC Screen Examples	15
1.3	Channels, Routing and Busses.....	18
1.4	Processing Blocks.....	19
1.5	Monitoring and Communication.....	20
1.6	Static Automation	21
1.7	Input Channel Block Diagrams.....	22

1 INTRODUCTION

1.1 Operating Features



Studer Vista 1 incorporates operating features that are applicable throughout nearly the whole console operation:

- Vistonics®
- Momentary/Latching Key Activation
- Ganging
- Copy/paste
- Scrolling
- FaderGlow®

These operating principles are described below, they are freely combinable. Some exceptions may occur where the combination of functions is not practical. The real speed and easiness of operation will become obvious to a sound engineer by using and combining these operating principles in every day life.

1.1.1 Vistonics®

Vistonics allows color and shape of controls to be varied according to good ergonomic practice. A given audio function is always associated with the same color, and a parameter is always associated with the same icon displaying values graphically – just as or even more intuitive than an analog console. Vistonics makes it possible to bring the location where you can see a value to exactly the place where you control it. Therefore, tiring translation processes between looking at a screen and finding the corresponding hardware control somewhere else are not existing anymore, saving just a little time and energy a few hundred times a day!

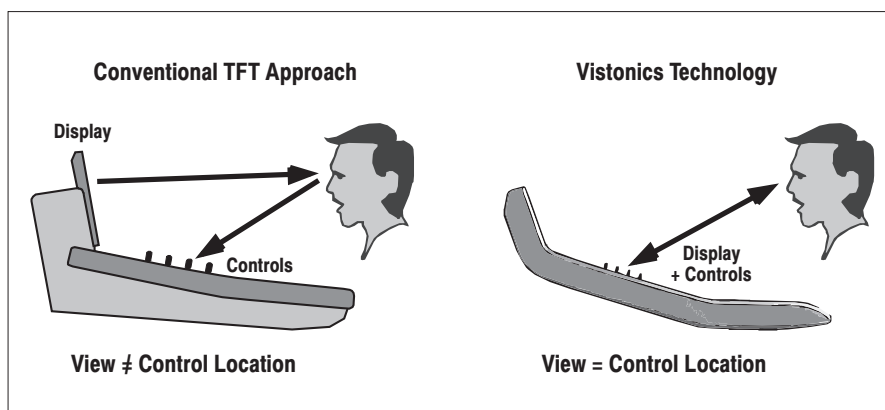

Great attention has been paid in order to make the current association clearly visible. Color coding has been used to indicate families of audio functions such as EQ, dynamics, etc. Consistent icons make the physical meaning of an audio function obvious – e.g. bar graph-like icons indicate levels, time adjustments are indicated by clock dials, etc. This way, it is easy to identify the currently associated function even from a distance.

The Vistonics module consists of two main parts: 40 rotary controls with push buttons next to each of them, as well as a touch screen area, showing graphically the most important settings of each channel: Dynamics, EQ and panning information. It is possible to change the association of a rotary control to audio functions either globally or locally.

Global Views Up to four different parameters are shown in each channel strip. The same four parameters will be shown globally on the whole console. This mode is meant to be the 'horizontal way of operation', mostly used for e.g. operating auxiliaries or input settings. The picture below shows a global AUX 1...4 view.

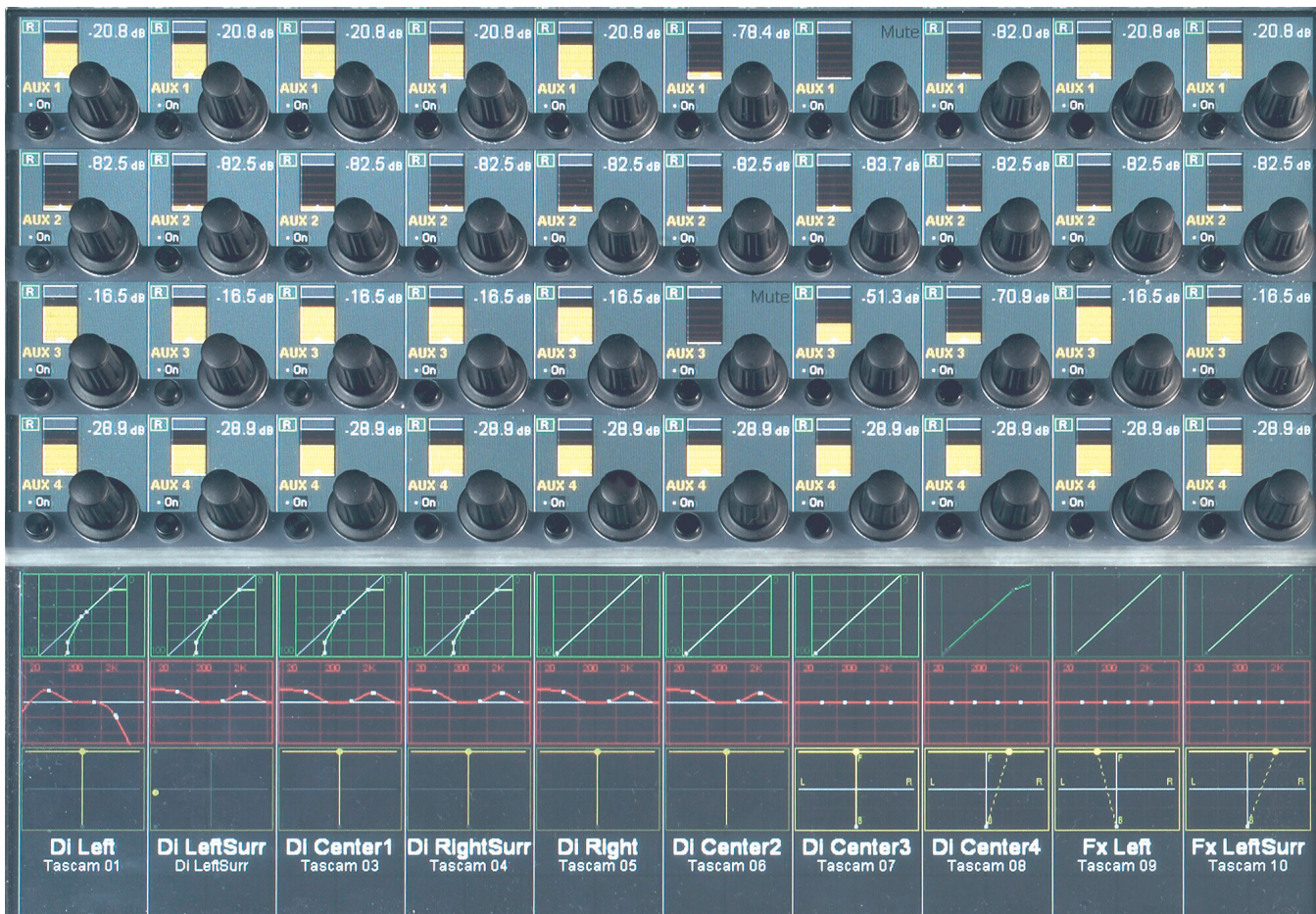

Global Bus Assign Overview

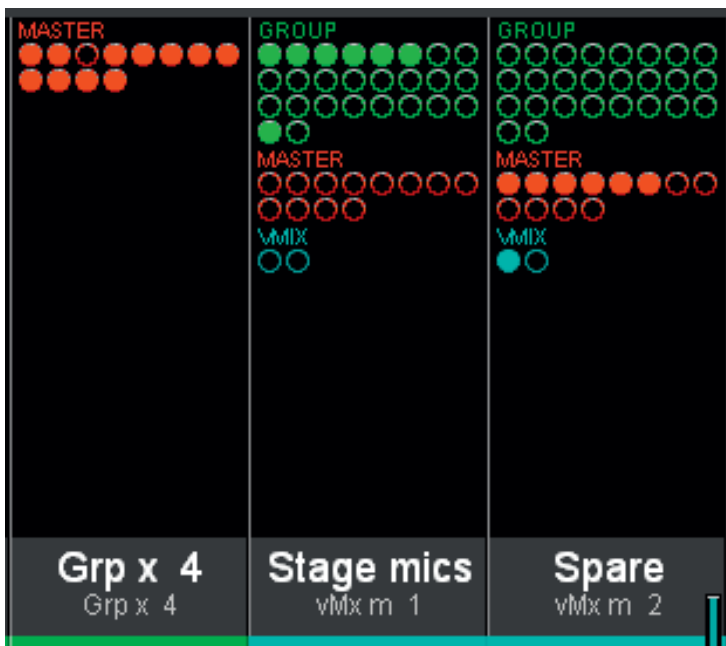

Local Views By touching the graphics shown below the Vistonics rotary controls, the whole parameter set of that specific curve is displayed, also covering some of the neighboring channel strips. It is also possible to touch any two curves in one bay in order to display both at the same time. The example below shows the complete dynamics section of the leftmost channel (the small dynamics view is highlighted), overlaid to a global AUX view.

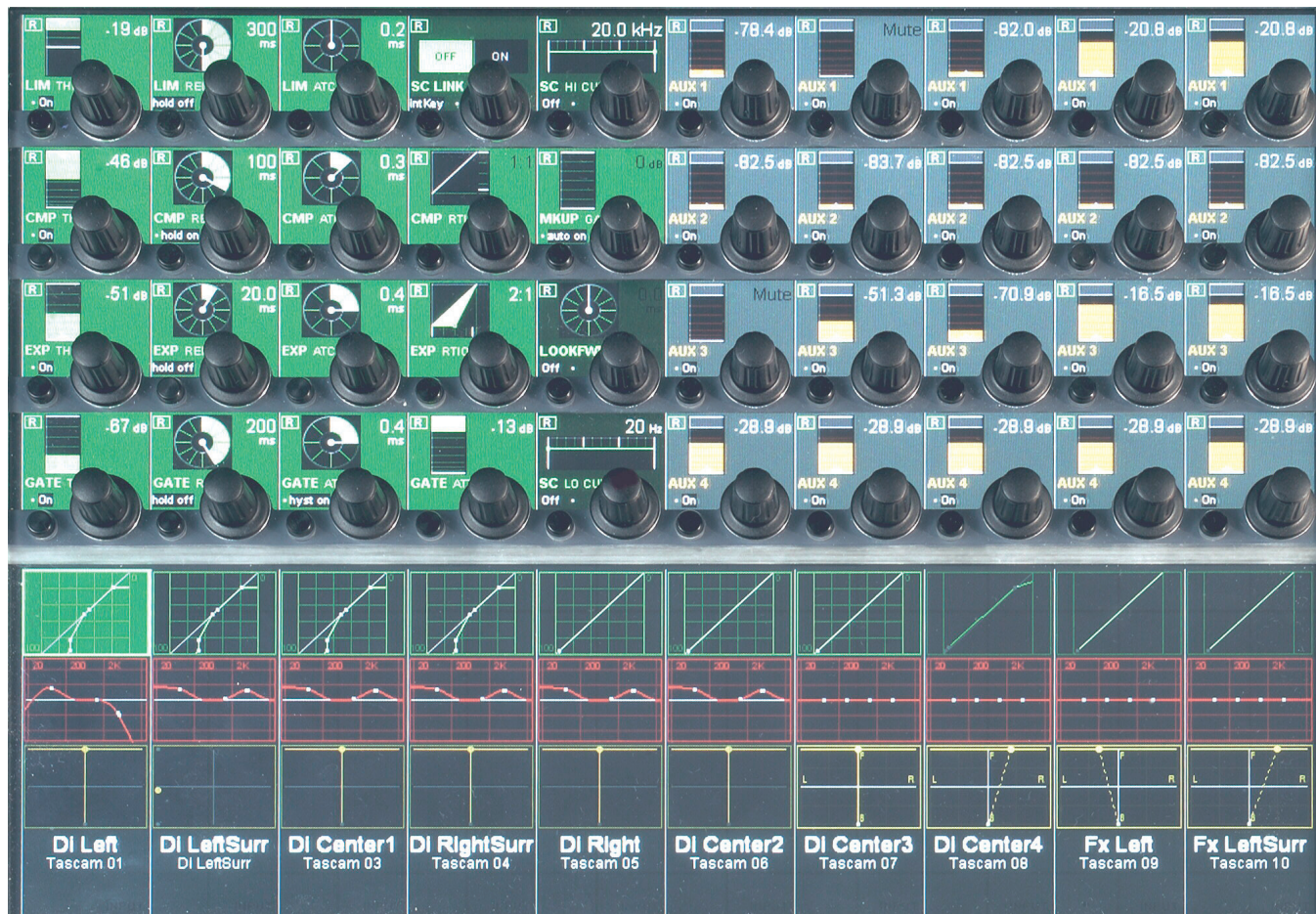

This philosophy is completed by three hardware keys underneath the Vistonics display, showing different combinations of parameters as well as the bus assignment of that specific channel, covering the whole Vistonics area.

Local Bus Assign View Channels may directly be assigned to a bus in this view.

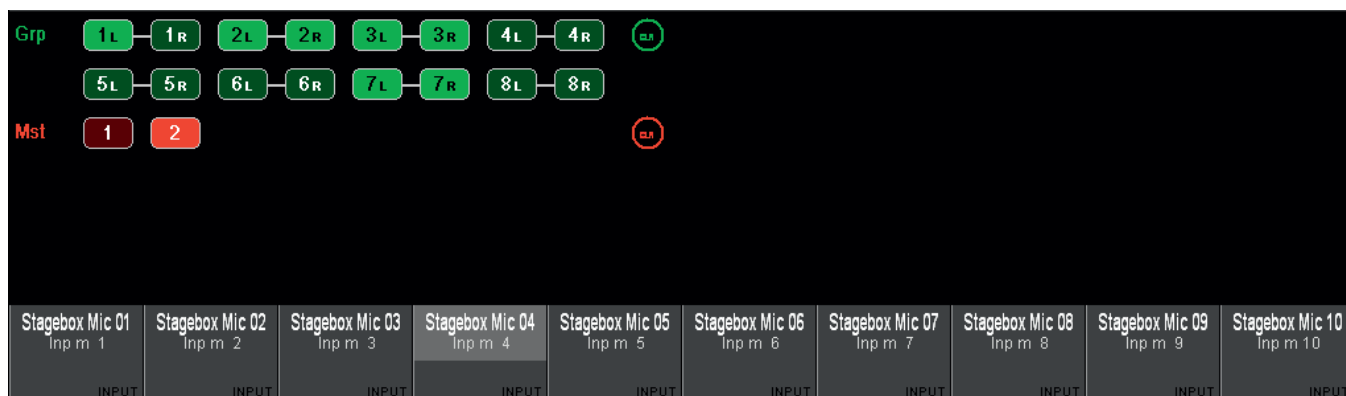

1.1.2 Momentary/Latching Keys ☺

A lot of key presses during console operation are repetitive in order to compare settings or to make quick checks for monitoring purposes. The Studer Vista console has reduced the amount of needed key presses tremendously by incorporating a special logic for these cases: The Studer Vista control surface distinguishes long and short key presses and reacts differently in both cases: Pressing and holding a key will automatically reverse its activation upon release of the key – this is, however, applied only where appropriate. All keys featuring momentary/latching activation are labeled with a ☺ symbol throughout this manual.

For example, holding down a **MUTE** key for one second will automatically unmute the signal again upon release. Further examples are ON/OFF switching of audio functions (EQ, filters, dynamics), PFL/SOLO as well as most of the monitoring functions: soloing different loudspeakers, muting loudspeakers, selecting alternate loudspeaker sets, etc. Keeping a monitoring source key or loudspeaker set key pressed will automatically go back to the previous selection upon key release. If you want a switch to be activated continuously, just press the key and release it immediately, without holding.

This automatism also works on view changes: Pressing and holding an EQ graphic will make all its parameters accessible for as long as the graphic on the screen is being touched. However, it will disappear immediately when the graphic is untouched. The same thing is possible for global view changes: Quick checks of bus assignments or auxiliary levels are as fast as never before.

This philosophy has also the advantage of not having to remember the last settings or views. The console remembers it automatically.

Note The threshold time for the momentary/latching distinction is adjustable in the Graphical Controller's 'Vista Desk Settings' screen.

1.1.3 Ganging

On top of grouping certain channels together in a way commonly known as VCA groups, Studer Vista has the ability to link multiple channels temporarily together and let them behave like one single channel. Such a link is called a Gang. It co-exists with VCA style groups (Control Groups) and is only a momentary help to influence multiple channels at the same time. A gang is created by pressing and holding one **LINK / SEL** key on one channel while the same key on a second channel gets pressed. This will link all channels between the two. By using the **MULTI SEL** key it is possible to select or de-select any channels on the surface without having them next to each other. The **MULTI SEL** key acts much the same as the Ctrl key on a standard PC keyboard.

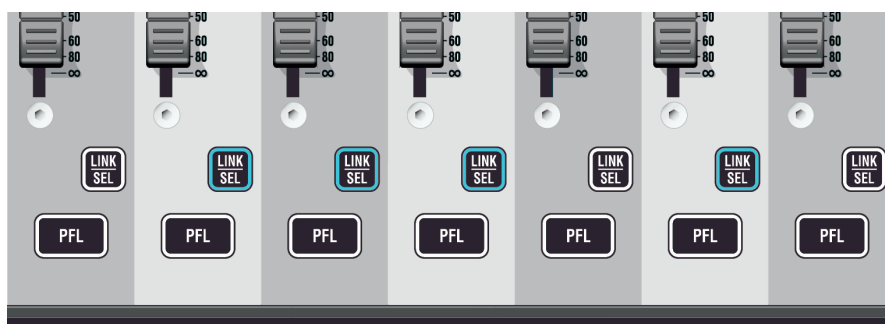

A gang is simply canceled by pressing any **LINK / SEL** key on the console again. Please note that *one channel is always selected*.

Temporary de-activation of a gang is done by simultaneously touching identical control elements (e.g. fader or rotary encoder) of *two* channels within a gang.

Typical Applications



- Trimming of some faders or auxiliaries by changing the corresponding control on any of the channels
- Copying a certain setting to multiple channels by pasting the value to any of the ganged channels
- Changing a bus assignment on all the ganged channels by changing it on one of them
- Changing dynamic automation modes on the whole gang.



Basically any operation on one of the ganged channels will influence all of them. Changing switches will *overwrite* the same switch on the other channels, while adjusting a audio function with a certain range will adjust all other channels in a *relative* manner. Setting all channels to the same value is accomplished by a copy/paste operation on one of the ganged channels.

Setting Up the Console



For setup application there is a fast way to link all channels of the same type together. Pressing **LINK ALL** followed by pressing the **LINK/SEL** key of one channel will gang all channels of that very same type together (e.g. all input channels). The gang may exceed the visible channels and may also contain channels in other sections. While having that gang active, you may setup your console within seconds: Changing bus assignment, clearing one channel or copy/paste certain values to any of these channels.

1.1.4 Copy/Paste

Copying certain audio settings across the console is made very fast and easy: Each channel strip hosts copy/paste keys dedicated to a certain audio function, as EQ, dynamics, etc. Pressing one of these keys will make it fully lit, while all possible destination channels (channels that also have this same audio function) will show up half-lit. Selecting anyone of them will paste the value into that channel. It is possible to paste a value to multiple channels with the help of the **MULTI SEL** key or by creating a gang. However, there is a shortcut to paste a value to multiple channels located next to each other: Press and hold the  (Copy/Paste) key of the first channel while pressing the  (Copy/Paste) key on the last channel. This will paste the value to all channels in between.



There is also a special  **A** (Copy/Paste All) key to copy a whole channel including bus assignment, as well as a  (Undo/Redo) key to undo the last paste or clear function on each channel separately. Pressing this key after an undo operation again will redo the last copy.

Note The  (Undo/Redo) key can be used momentarily (long press) in order to compare settings on a channel:

- 1 Press the  (Copy/Paste) key twice in order to ‘memorize’ the current setting (i.e., by pasting it to itself)
- 2 Adjust the audio function to an alternative setting
- 3 Press  (Undo/Redo) multiple times (either short or long) in order to compare the two settings.

Half-Lit Keys Whenever the console is waiting for a key press in order to finish a function, it will illuminate all possible keys by half. This is a guide for the user – so he can select one of these keys, or reverse the function by pressing the first (fully lit) key again. A timeout applies if none of the half-lit keys are pressed within a given time frame. Timeout duration is adjustable in the ‘Vista Desk Settings’ menu in the GC.

Examples:

 (Copy/Paste) >  (Copy/Paste),

LINK ALL > **LINK/SEL**,

Setup of control groups, etc.

1.1.5 Scrolling

Vista 1 has more channels available in the DSP core than there are physical faders on the console surface. Most manufacturers deal with that fact by introducing ‘layers’. The console surface can be switched in order to show the different layers, all of which making all DSP channels available to the user. The Vista operating philosophy has modified this concept: Rather than thinking of layers sitting on top of each other, we think of the layers being arranged on a horizontal line. The ‘Layer’ is now called ‘Section’. The six sections are next to each other on an imaginary horizontal line.

As long as the user wants to switch to a specific section, there is no difference in operation to the ‘layer’ concept. Changing to another section is accomplished by pressing one of the corresponding keys in the **SECTION** area of the fader bay or with the adjacent < / > arrow-shaped keys (see below, left).

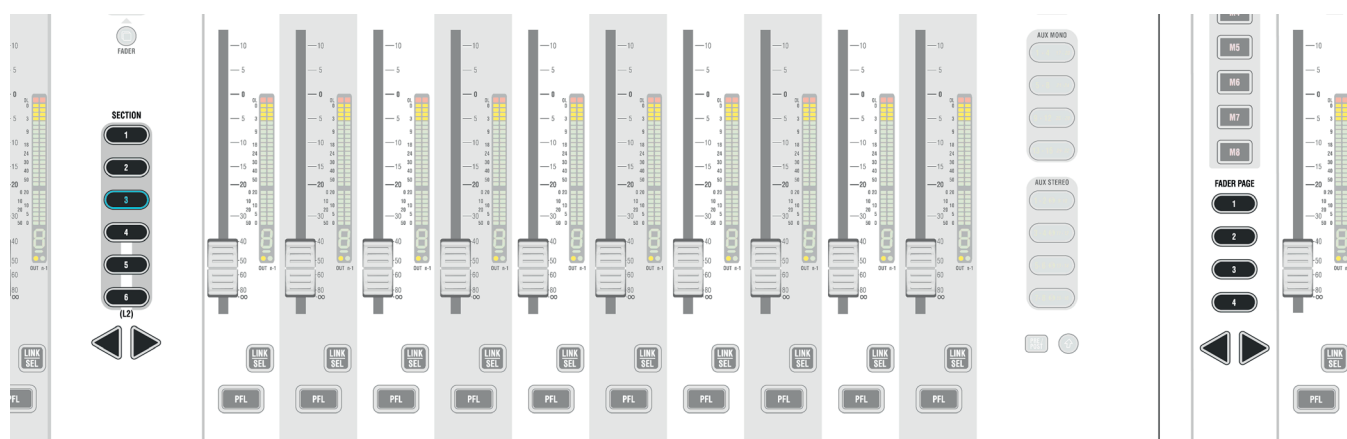

Information on which section is currently displayed is given by the lit key(s) in the fader bay’s **SECTION** area. The graphical controller’s ‘strip setup’ window shows clear overviews of fader bay and control bay; it will also indicate the section currently displayed on the desk by putting a dark background to the corresponding channels.

If **FOLLOW** is active in the control bay, the bay can be used as an additional fader bay. However, it scrolls independently from the fader bay, using the **FADER PAGE** keys at the left of the control bay (see above, right).

Desk Navigation Example

Let’s assume a 32-fader desk. 20 of them are normally used for inputs. Since the desk can jump to six sections, up to $6 \times 20 = 120$ DSP channels can be operated. *It is, by the way, possible to have the same DSP channel visible in multiple places within these six sections.*

- Step 1** The user defines the order of these 120 DSP channels in the strip setup dialog box in the GC. There he will find six empty sections with 30 placeholders, each for a channel assignment. The definition will most likely be made in such a way that the user starts with a new section when he starts with new channel type (as shown in the example below).

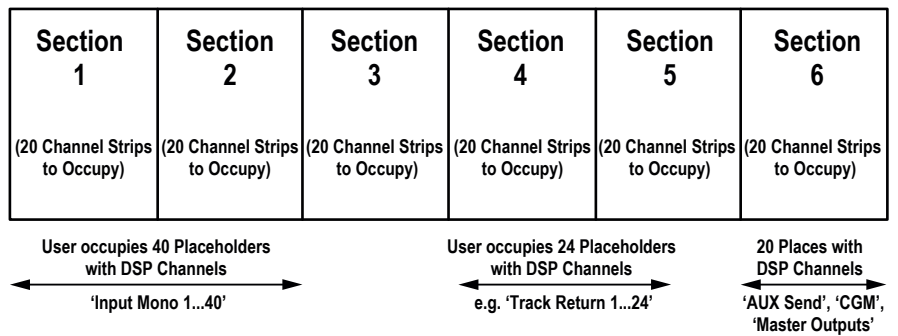

Step 2 The user can now navigate through the 6-sections-wide ‘virtual surface’ in two ways: Either he ‘jumps’ to a specific section by pressing the corresponding key in the control bay (each ‘jump’ being 20 faders wide), or, by pressing one of the arrow keys will virtually move the physical surface in front of the total console (6 sections) by one bay (10 faders) at a time in the corresponding direction (like moving a chair in front of a huge console).

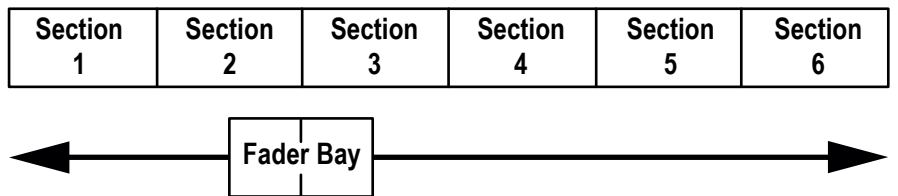

The Difference from the Layer Concept

Rather than just switching to another section, it is possible to scroll through the sections by pressing any arrow key. This will make the physical surface scroll through all sections with a step size of ten channel strips. It is therefore possible to move any channels close to the operator’s position, allowing him to stay in the ‘sweet spot’ at all times. This concept can also be imagined like moving a chair in front of an analog console. On Studer Vista, you move the surface of an imaginary console several times larger than the physical console to the left or right. Which DSP channel is shown where is defined in the ‘strip setup’ dialog in the Graphical Controller (refer to [chapter 4.4.6](#)).

1.1.6 FaderGlow®



During a hectic live production, FaderGlow provides the operator with an instant overview of the fader function by illuminating them in one of eight different, freely-assignable colours.

Now the operator can mark individual, important channels such as presenters, main talents and other ‘must-never-lose-their-signal’ channels. Once the important channel is colored, it can be found within a fraction of a second, even after mixing on a different layer and coming back to a channel layout that may not have been on the surface for some time. Moreover, FaderGlow allows the operator colouring entire channel groups (such as ‘band’, ‘guest’, ‘ambience’, ‘string section’, ‘rhythm section’ channels), in order to distinguish them easier and locate them faster. One of seven different colours can be assigned to any channel strip.

For FaderGlow configuration details refer to [chapter 4.4.6.1.7](#).

1.1.7 TFT Level Meters (Option for 32 fader Vista 1)

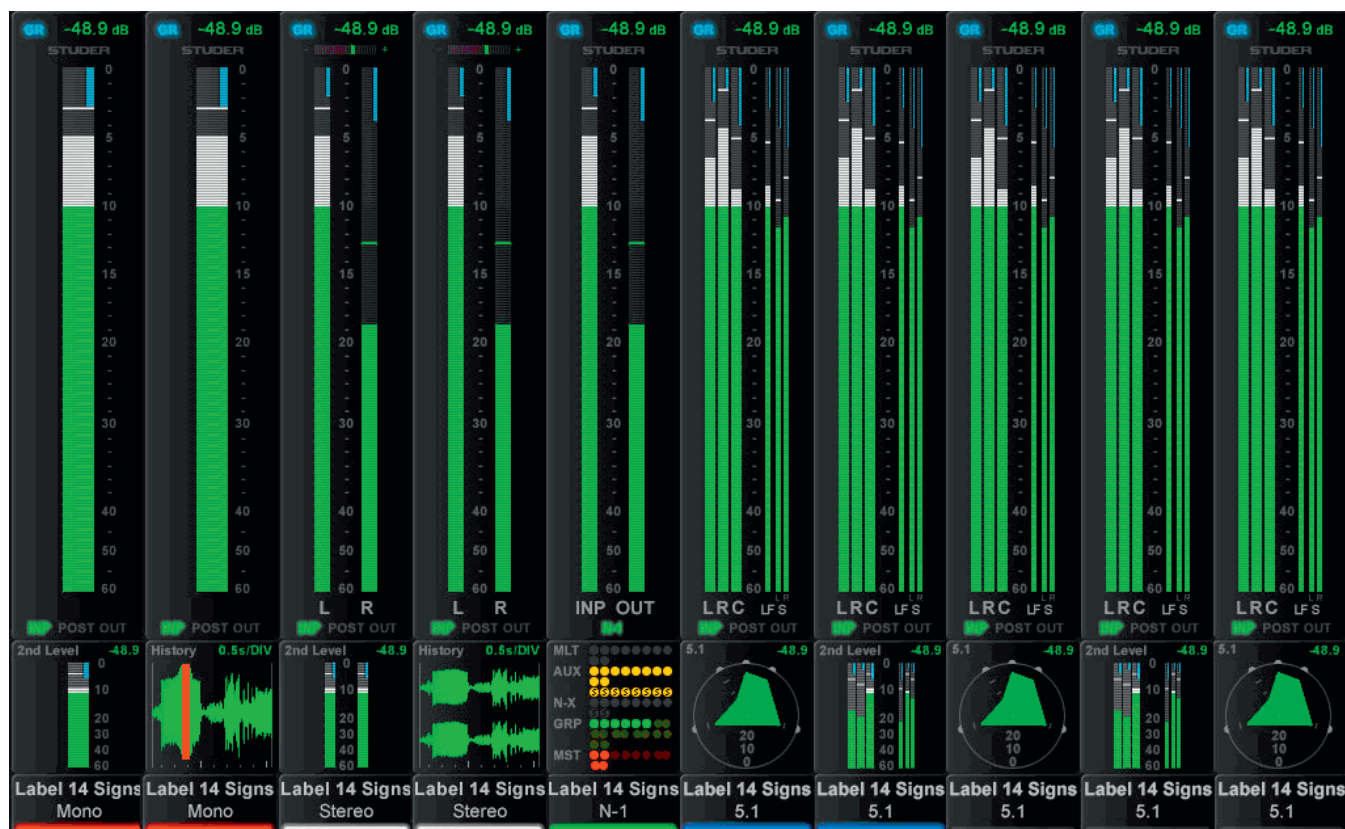

As an option, additional TFT screens may be fitted to the top of the 32 fader desk to provide a full mono, stereo or surround meter for every fader on the desk. The illustration above is an example of a meter screen, with mono, stereo and surround channels and different views in the lower area – such as metering of the L2 channel, history, bus assignment and surround view. Further information is displayed as well, such as fader glow color, gain reduction, correlation for stereo signals, or surround signal type.

Normally the meter assignment automatically follows the fader assignment both for audio and for meter display type. 1., 2 or 6 green/white bars display the audio level according to the fader channel format. At the bottom of the main meter is an indication of the source of the signal in the channel path; INP = pre processing, POST = post fader, and OUT = direct output (only valid if routed to a physical port). Below the main meter is an assignable display that shows one of the following:

- Audio level monitoring of the equivalent channel on the layer 2 fader 'L2' mode (only available if 'L2' mode is enabled)
- Audio waveform display; shows the audio history which is very useful for finding clicks and overloads
- Bus routing display
- Surround vector type display (for surround channels only)

The control bay metering differs from the meter screen on the fader bays; it is mainly made to show output channels. Different meter views are available for this screen. It can be switched to a predefined meter view to see all auxiliary outputs. Or to all groups, or all programme masters, direct outs, bus outputs, N-1s, matrix channels, etc. In addition there are user pages assignable to

whatever is desired via the strip set-up. There are four configurable user page pages, one with ten slots in one row, one with 20 slots in two rows, and two with 40 half-width slots in two rows. So if calling up page four, there are 40 meters, and they can be virtually anything. The two meter slots at the right of the control bay TFT screen continuously show PFL and CR levels.

TFT meter configuration is performed in the GC's strip setup screen. Refer to [chapter 4.4.6.1.6](#).

1.2 The Graphical Controller (GC)

An important feature of the Vista Digital Mixing System is the Graphical Controller, also referred to as 'GC'. The Graphical Controller application can be used for operating all mixing console functions as well as to extend the console functionality.

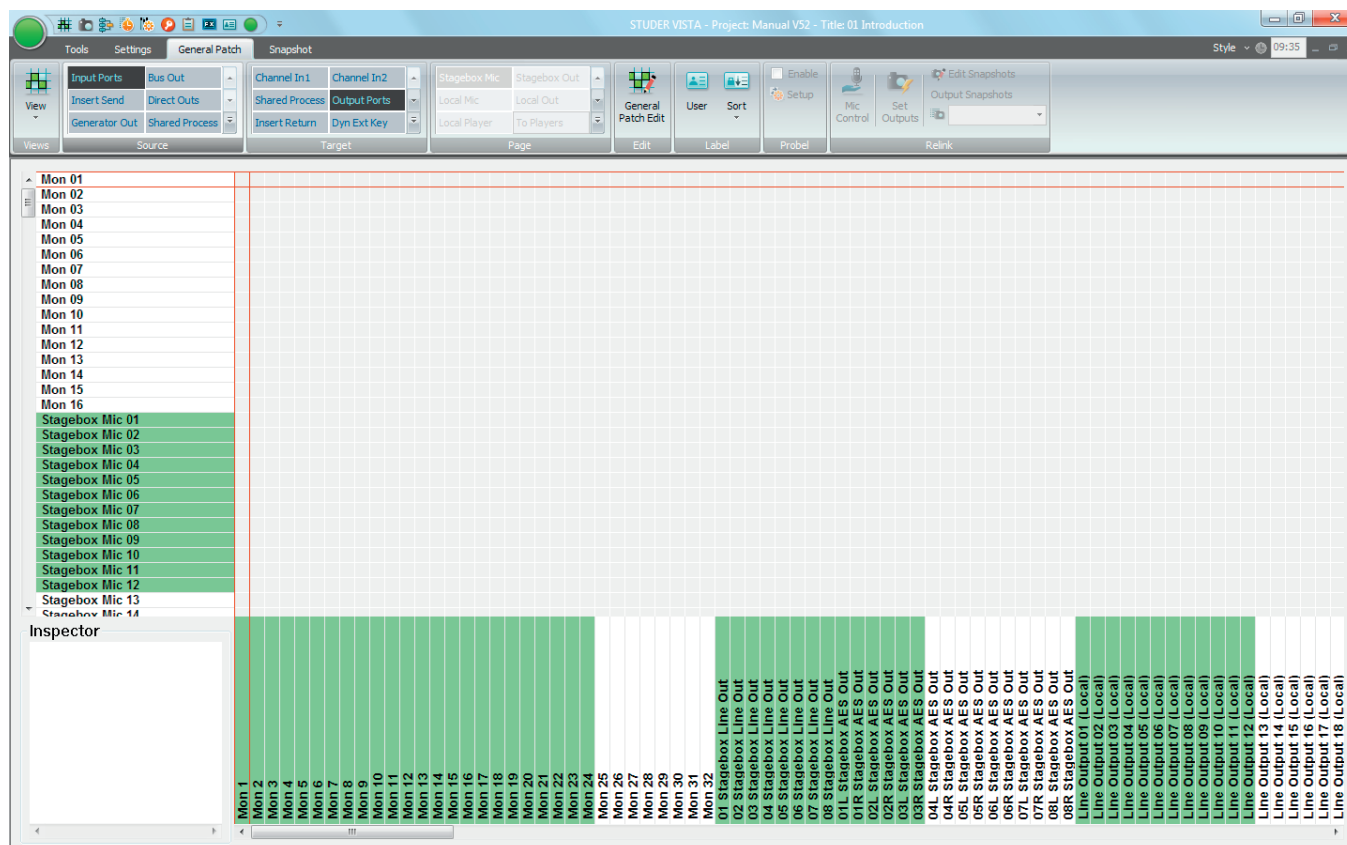

Specifically, the Graphical Controller's extended functions include:

- General and channel-specific router control (defining the order of processing elements, e.g. EQ or dynamics libraries, within a channel)
- Recall and management of snapshots and cue points
- Saving of desk clipboards
- Assignment of the DSP channels to the fader strips
- Tone generator and metering control
- Control group and linkage control
- Production and Title management
- System administration

Various display windows and dialog boxes logically group the individual functions. Visual elements are optimized for simple and intuitive operation.

With the help of the easy-to-understand General Patch page, the setup of router cross points is dramatically simplified, even for large mixing console configurations. Via a Snapshot window, all mixing console parameters can be stored and recalled using mouse clicks. Some of its most important functions are also available as dedicated keys on Vista's control bay.

The concept of overall system configurability has been also adopted within the Graphical Controller application. Since most functions are arranged in overlapping windows of changeable sizes, users can set up their work environment to suit their specific requirements for each recording or production session. These settings can be saved and recalled at any time, allowing for fast and application-oriented operation of the Vista system.

1.2.1 GC Screen Examples

Channel Patch: Internal Routing Matrix Control

The Channel Patch screen is an audio path-oriented view for controlling the routing of a particular channel, and is used to set up the sequence of channel processing blocks (EQ, Insert, Delay, etc.) and metering locations within the signal path, as well as defining the direct out signal. This screen also displays the connections made to the channel's various inputs and outputs. By double clicking on one of these display boxes the system will go directly to the associated connection in the General Patch. The Channel Patch also includes labeling and dynamics link facilities.

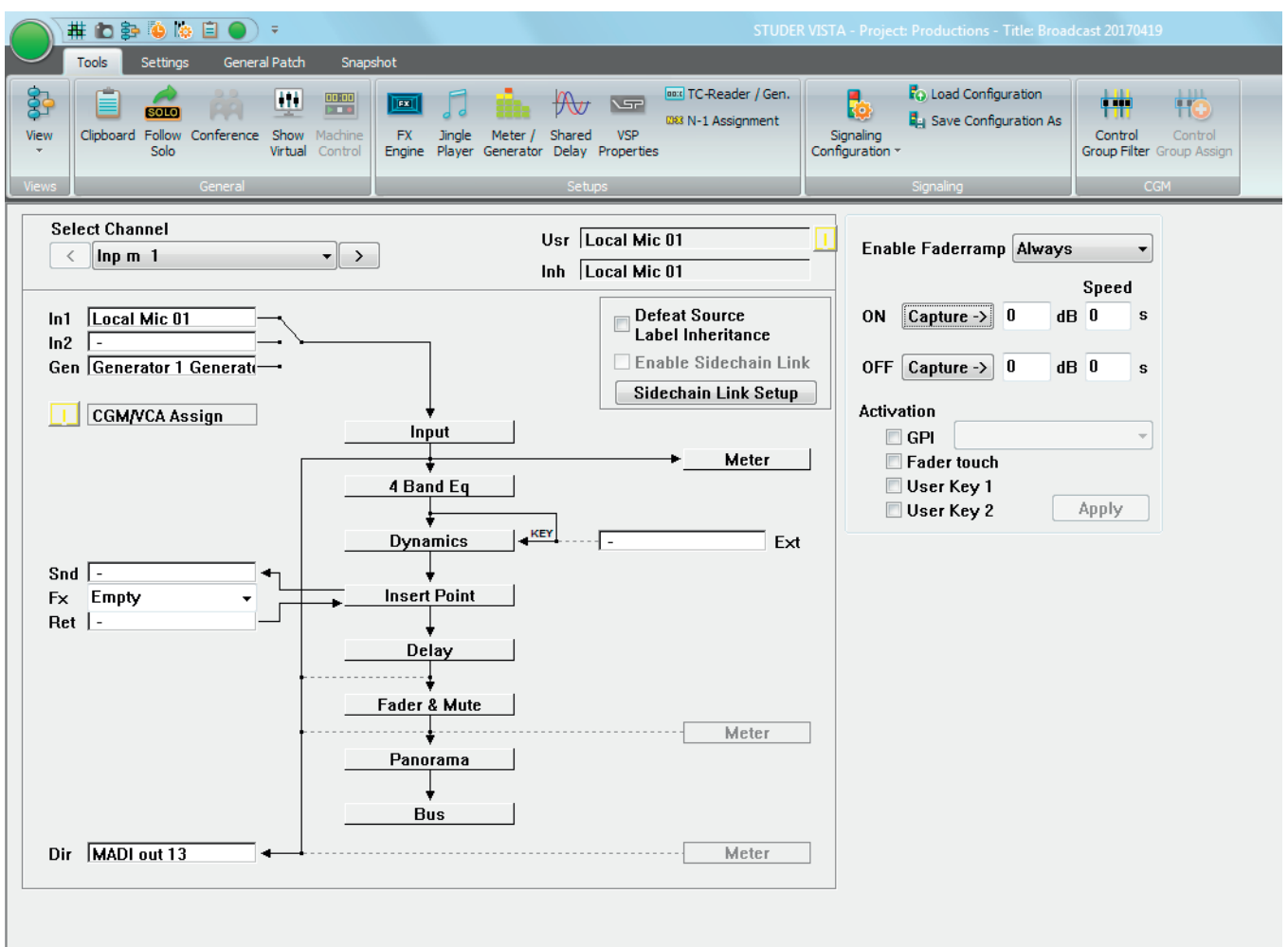

General Patch Within the General Patch window, the various cross point routing of sources and targets (destinations) is displayed. For example, it will show which audio signals (AES/EBU in, Direct outs, etc.) connected to the DSP sections are assigned to the corresponding channels and outputs (Input channel, MADI out etc.). These connections are stored within Snapshots and Presets. The sources and targets can be identified by Fixed, Device or User labels.

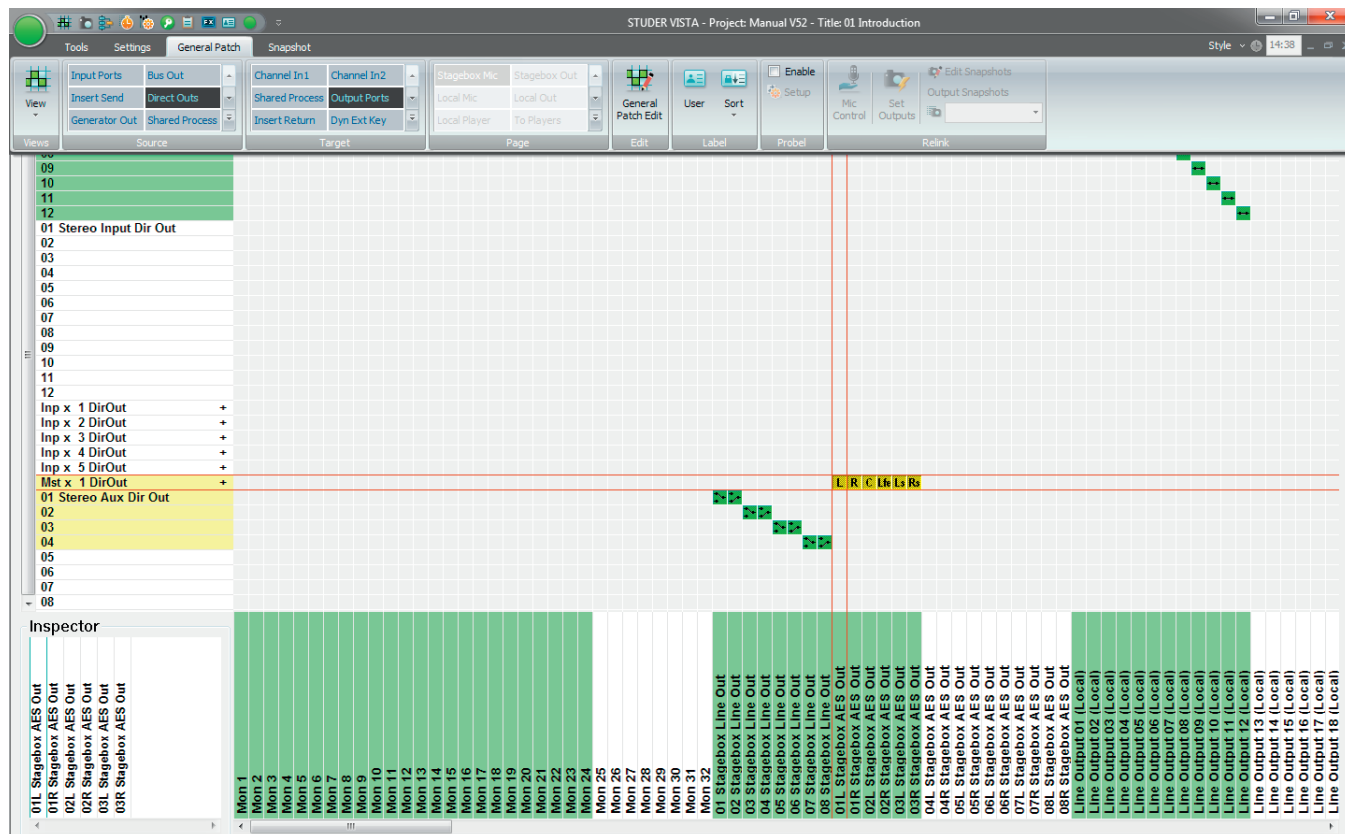

Snapshot Functions Display and control of snapshot settings (in other words, complete ‘pictures’ of the operating desk’s controls and of the console’s internal settings) and factory/user presets provide basic working templates.

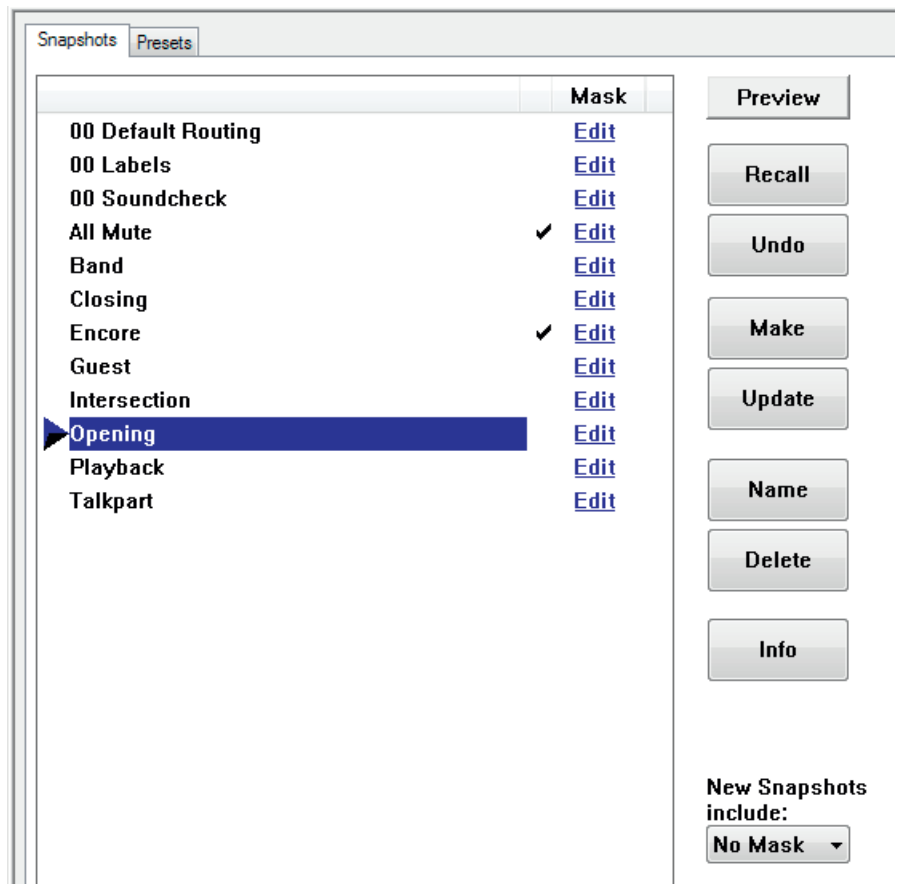

Control of snapshot filters and channel protection is achieved via separate windows:

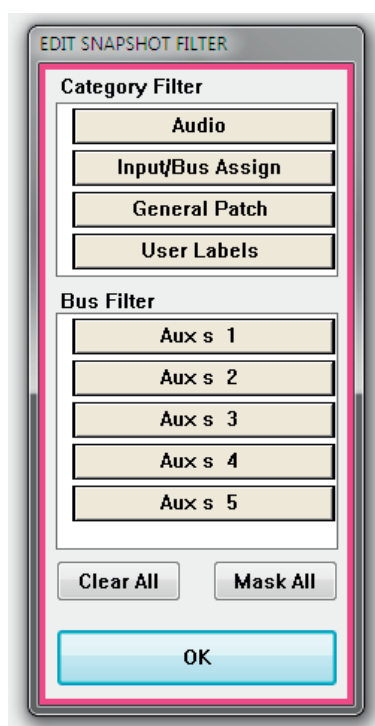

1.3 Channels, Routing and Busses

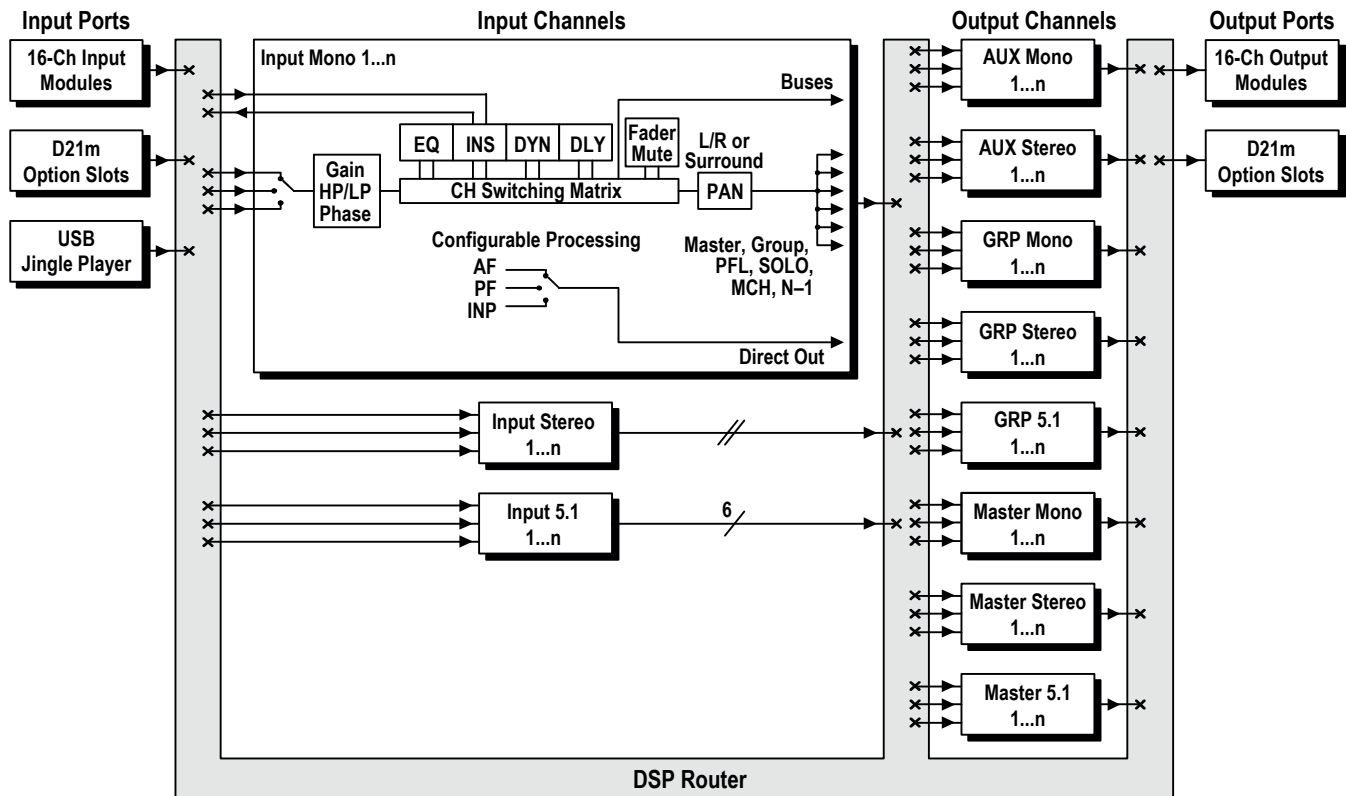

Processing blocks, such as equalizer, dynamics, delay, etc., can be configured for all channel types.

Input Channels

Vista's digital routing matrix is located between the console's physical inputs and the actual DSP channels. This topology means that the physical analog and digital inputs can be assigned to any console channel via the General Patch page on the Graphical Controller. The patch setup forms part of each individual snapshot, and can be saved, updated and recalled within the Snapshot/Preset system.

Output Channels

This also applies to the outputs. On the General Patch page, each channel's output can be selected and sent to any analog or digital output destination.

Auxiliary Busses (AUX)

The number of stereo or mono AUX sends is pre-defined by the configuration currently loaded – four configurations are shipped with the console to select from. The AUX master channels are equipped with a selection of processing blocks such as equalizer, dynamics, delay, and more (or less).

Clean-Feeds/Mix-Minus (N-X)

Mono or stereo clean-feeds/mix-minus busses (also referred to as 'N-X') are also part of the configuration currently loaded.

Multi-track and Group Routing

Multi-track and group routing is part of the currently selected configuration, as already mentioned above.

Solo Modes

Each channel features a Solo and a PFL Switch. Depending upon the mode selected within the control bay the SOLO key is active as SOLO or Solo-In-Place. Clearing these buttons can be achieved by opening the corresponding fader in case 'PFL BC' (Broadcast) is active. A very handy PFL/Solo Reset is provided to disengage any solos regardless of where they are engaged on the console. This eliminates the need to 'search' for solos with large console configurations. A key to define certain channels to be safe from being muted in 'Solo-In-Place' mode is also provided. This set will be stored with each title.

1.4 Processing Blocks

Parametric Equalizer Four fully parametric bands are provided on the Vista. Each band, which can be switched in and out independently, extends from 20 Hz to 20 kHz, with a ± 18 dB gain range. The EQ features a psycho-acoustically corrected frequency response for high frequencies, similar to well-known analog EQ designs. The two mid-bands can be switched between constant-Q and constant-range modes. The high and low frequency bands can be switched to shelving mode. A second EQ type is available (defined by the configuration currently loaded) that features an additional Notch filter.

Graphic Equalizer Also available is a BSS® 30-band graphic EQ for input channels, groups, masters and auxiliaries. The graphic EQ may be shown and adjusted by 30 of the faders when selected with a single desk key. As soon as any other control except a fader or a channel mute key is touched or operated, fader operation is immediately cancelled and switches back to normal mode. The FaderGlow colour of these 30 faders will change to red, making it unmistakably clear that currently the faders are dedicated to the graphic EQ function. The Vistonics icon of the channel with the EQ on the faders is highlighted, all others are blanked.

Both the graphic and the parametric EQs can be used individually or simultaneously, for all or specific channels only; the current setup is depending on the configuration currently loaded.

Filters Low-cut and high-cut filters are provided, with cutoff frequencies that are variable between 20 Hz and 20 kHz, and slope selections of 12, 18, or 24 dB/octave.

In addition, an analog low-cut filter with a cutoff frequency of 75 Hz and a slope of 12 dB/octave is available in the D21m Mic/Line preamplifier.

Dynamics (Standard) The Vista *standard dynamics* processing consists of four parts: Limiter, Compressor, Expander, and Gate. To avoid pumping and modulation, the dynamics processing sections feature high sampling rate transient detection. Distortion artifacts are minimized through selectable, program-dependent attack and release times. The Vista's dynamics feature a side-chain input that can be used with or without HP/LP filters. A unique 'look forward' function is also featured. If desired, this allows the entire transient portion of a waveform to be affected when using the limiter/compressor or to be passed when the expander/gate is used.

Dynamics (Vintage) Sometimes the dynamics processing can be utilized in a more pronounced way, i.e., as an effect itself. For this purpose the '*vintage dynamics*' was created. It is targeted to be flexible enough for different types of sound coloration including extreme and unusual settings, but does not feature a dedicated limiter.

Selection between the standard or vintage dynamics section can be made per input channel during configuration of the console.

Soft Clip In addition, a soft clip function can be activated in the D21m Mic/Line preamplifier.

1.5 Monitoring and Communication

Monitoring The Control Room (CR) monitoring section provides control of two different speaker systems; one of them is multi-channel, the other one is two-channel stereo and is normally used for the near field monitor speakers. All internal digital sources can be assigned to any of the source selector keys, and up to 32 source selector keys are available. A headphone socket for control room monitoring is located at the console's right front edge below the hand rest. The Studio Monitor is configurable in the same way as the CR monitor section. Two stereo loudspeaker pairs are supported.

Talkback An extensive talkback system is implemented within Vista. The talkback source can be either the desk operator's microphone or an external producer microphone. Several destinations, such as busses, direct outputs, auxiliaries, groups, and master outputs are available block. Each channel is fitted with a talkback key that activates talkback to the direct output of the corresponding channel and, if the channel is an N-X owner, to the N-X output. For details see the block diagram below.

Talkback and Signaling Block Diagram **VISTA 1** Using Desk-Internal GPIO

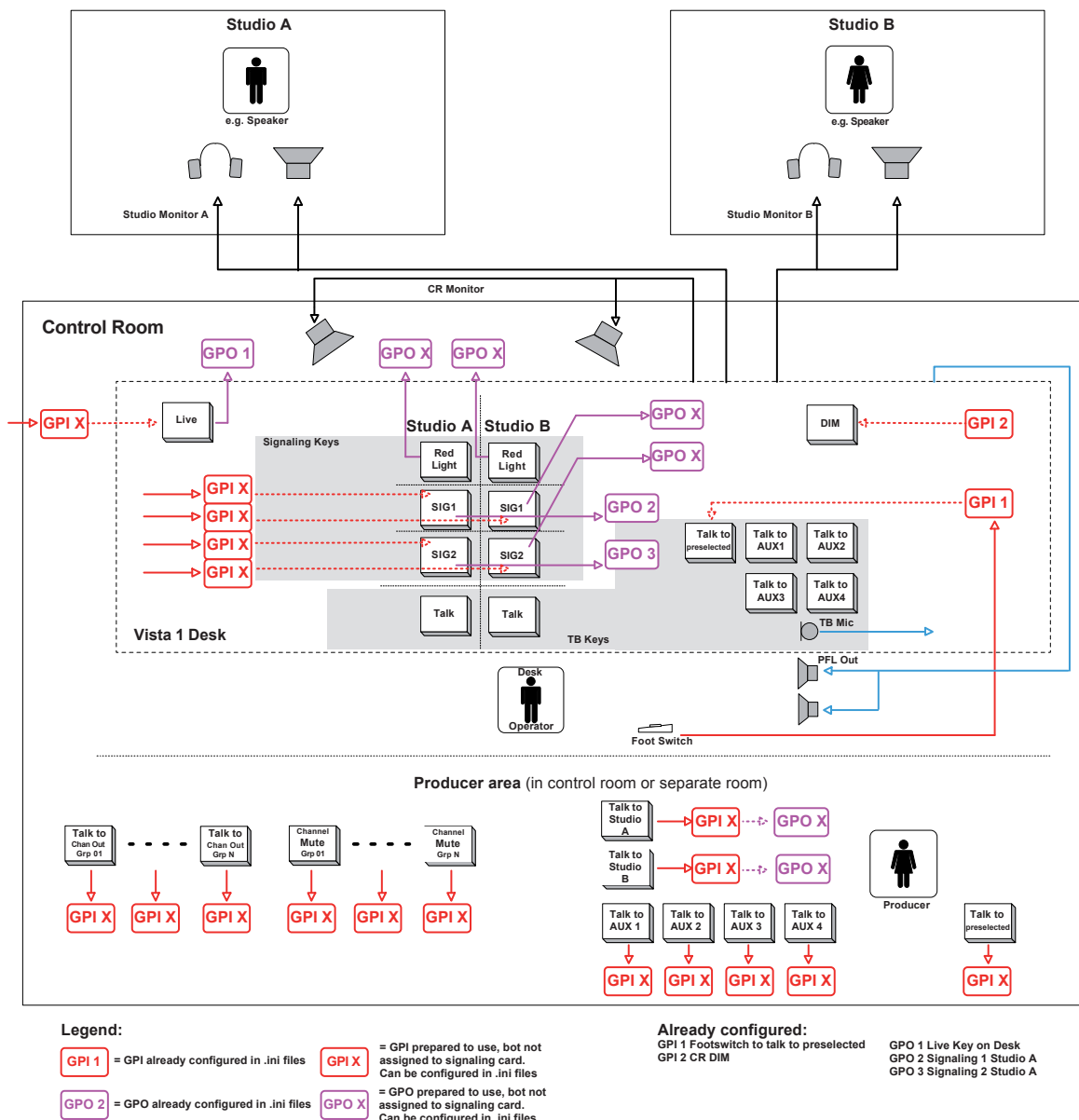

1.6 Static Automation

Snapshots An unlimited number of snapshots can be captured, saved, and recalled for each Project Title. All control parameters of the console are saved in the snapshots. When a snapshot is recalled, the console typically requires 120 ms to fully reset itself. Snapshots recalls can be done with snapshot filters active, protecting certain console parameters from being changed by the recall. Extensive editing functions allow modifying snapshots after or during a live show. Besides absolute protection of certain parameters it is possible to trim parameters relative to their stored values rather than letting them totally unmodified.

Presets Recalling a preset, however, will ignore any snapshot filters which may be active, and bring the console into a clearly defined audio state.

Copy & Paste Clipboard The Vista System supports copy and paste of some or all channel settings to one or more other channels. This ability streamlines the set-up of the console when an operator is starting from scratch with a new layout. However, if starting from a clean slate is desired, clearing all or some of the parameters is possible as well.

Cue List / Theatre Cue List Two different cue list functionalities are available that allow sorting snapshots and attaching MIDI and HiQNet commands to each of them. Each title can contain one cue list. It can be controlled from external controllers using MIDI. It is possible to use standard 'MIDI show control' commands as well as recalling certain cues with a user-defined MIDI command (note or program change). *Theatre Cue lists are only available in 'static' mode, hence not when dynamic automation is active.* Opening the cue list is done either by clicking on the *Cue List Icon* in the GC screen's View Button, or by using the **CUE: LIST** key on the control bay. For details and a theatre cue list tutorial, refer to [chapter 4.4.5](#).



1.7 Input Channel Block Diagrams

Block Diagram of a Typical Mono Input Channel:

Essentially, all channel types have the same structure, regardless of the type (input, AUX, group, master, etc.)

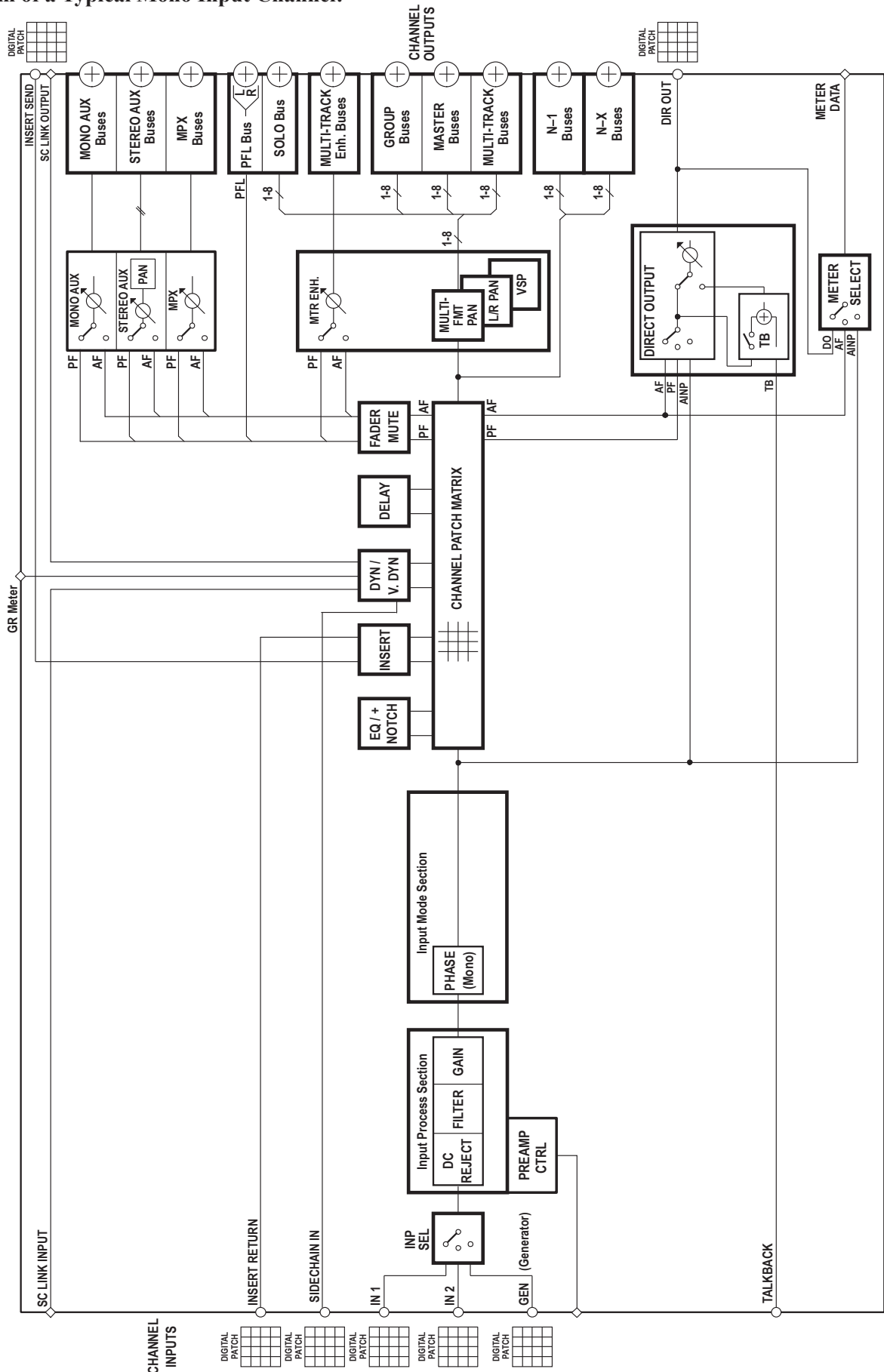

Block Diagram of a Typical Stereo Input Channel:

Essentially, all channel types have the same structure, regardless of the type (input, AUX, group, master, etc.)

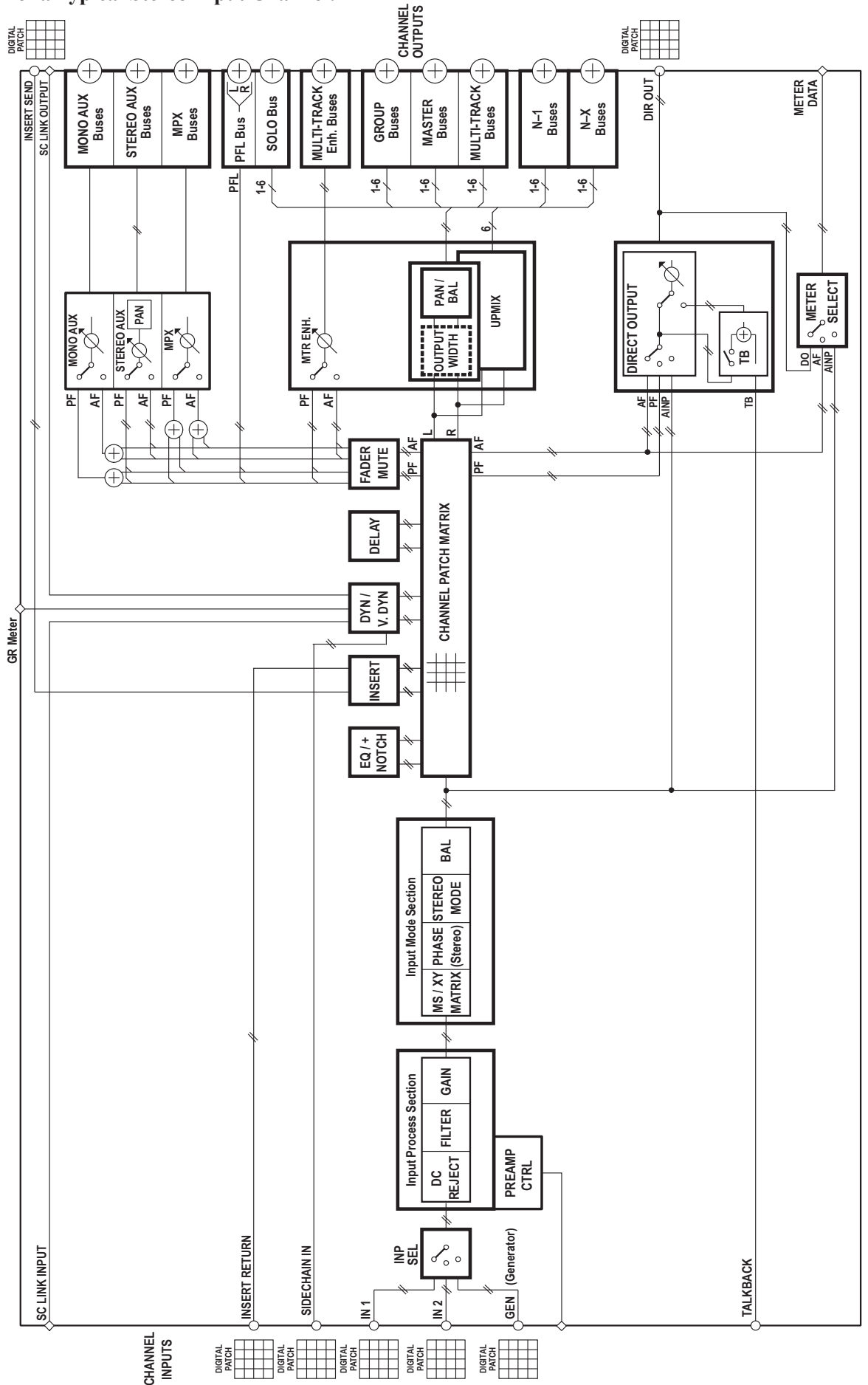

Block Diagram of a Typical 5.1 Input Channel:

Essentially, all channel types have the same structure, regardless of the type (input, AUX, group, master, etc.)

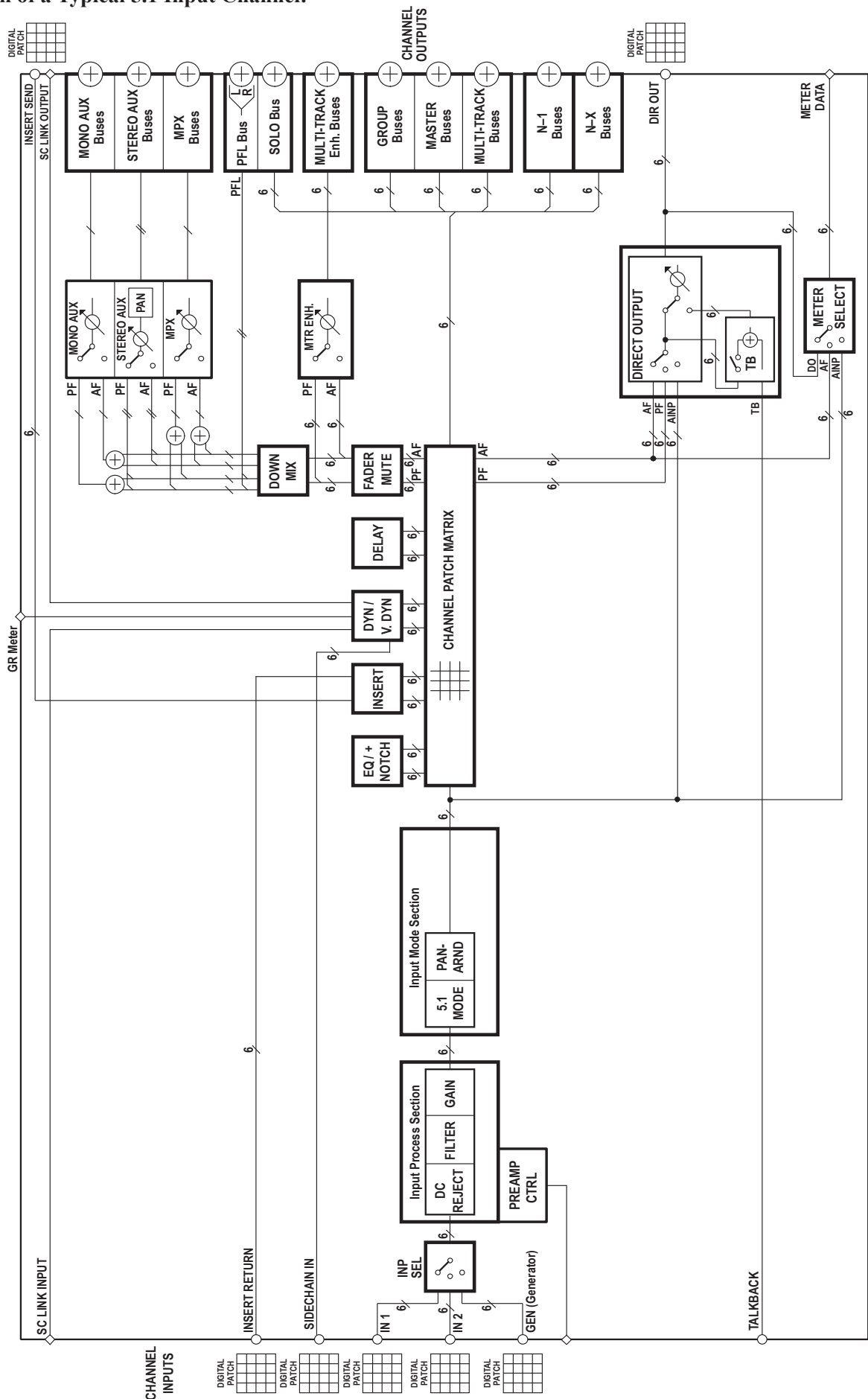

CHAPTER 2

2	General Info / Desk Operation	3
2.1	General.....	3
2.1.1	Utilization for the Purpose Intended	3
2.1.2	First Steps.....	3
2.1.2.1	Unpacking and Inspection.....	3
2.1.2.2	Adjustments, Repair, Cleaning.....	3
2.1.2.3	USB Sockets	3
2.1.3	Technical Specifications (subject to change without prior notice)	4
2.1.3.1	Dimensions.....	5
2.1.4	Connectors.....	6
2.1.4.1	Rear Panel Connectors	6
2.1.4.1.1	Connector Area 5.....	7
2.1.4.2	Front Connectors.....	11
2.1.5	Monitoring/Talkback Inputs/Outputs	12
2.1.5.1	‘Vista 1 Mono/Stereo/FOH/Monitor’ Configuration Templates	12
2.1.5.2	‘Vista 1 Surround’ Configuration Template.....	13
2.2	Desk Operation	14
2.2.1	Vistonics® Operation / Local Views	15
2.2.2	Fader Area	17
2.2.2.1	Channel Meters	18
2.2.2.2	Channel Selection	19
2.2.3	Global Views	20
2.2.4	Central Channel Processing Keys	21
2.2.5	Control Bay Details.....	24
2.2.5.1	System/TB/Headphones.....	24
2.2.5.2	Assignable Meters and Meter Selection.....	25
2.2.5.3	Control Room Monitoring	26
2.2.5.4	Studio Monitoring.....	29
2.2.5.5	Monitoring Source Selection	30
2.2.5.6	Custom Panel (GPIO Keys).....	31
2.2.5.7	Jingle Player.....	31
2.2.5.8	Talkback Control	32
2.2.5.9	Control and Mute Group Setup.....	34
2.2.5.9.1	Control Group Setup	34
2.2.5.9.2	Mute Groups.....	34
2.2.5.9.3	Setting up a Mute Group.....	35
2.2.5.9.4	Off-Air Conference	36
2.2.5.10	GC Shortcut Keys	37
2.2.5.11	Cue List Keys.....	38
2.2.5.12	Joystick.....	39
2.2.5.13	Fader Page Navigator.....	40
2.2.5.14	Grand Master Faders.....	41
2.2.5.15	Stereo Channel Fader Unfold on Grand Masters	42
2.2.5.16	Output Views / FOLLOW	44
2.2.5.17	Contribution Access	46
2.2.5.18	SpillZone.....	47
2.2.5.19	Follow Solo.....	51

2.2.6	Fader Bay Details	53
2.2.6.1	Channel Control	53
2.2.6.1.1	Activating Two-Layer Mode	53
2.2.7	Clipboard Libraries	55
2.2.7.1	Clipboard Library Window	56
2.2.7.2	Paste to Clipboard Library	56
2.2.7.3	Copy from Clipboard Library	56
2.2.7.4	Rename/Delete a Clipboard Library File	57
2.2.7.5	Clear the Display	57
2.2.7.6	Update a Clipboard File	57
2.2.7.7	Storage Format	57
2.2.7.8	Import a Clipboard File from Another Library	58
2.2.7.9	Where are Clipboard Libraries Saved?	58
2.2.8	Console Illumination	58
2.2.9	Jingle Player Operation	59
2.2.10	FaderGlow®	62
2.2.11	Optional TFT Level Meters	62
2.2.12	Virtual Vista	66
2.2.12.1	Screen Layout	67
2.2.12.2	Fader Bay View	68
2.2.12.3	Control Bay View	69
2.2.12.4	GC View	71

2 GENERAL INFO / DESK OPERATION

2.1 General

2.1.1 Utilization for the Purpose Intended

The Vista 1 mixing console is intended for professional use. It is presumed that the unit is operated only by trained personnel. Servicing is reserved to skilled technicians.



The electrical connections may be connected only to the voltages and signals designated in this manual.

2.1.2 First Steps

2.1.2.1 Unpacking and Inspection





Your new mixing console is shipped in a special packing which protects the units against mechanical shock during transit. Care should be exercised when unpacking so that the surfaces do not get marred.

Verify that the content of the packing agrees with the items on the enclosed shipping list.

Check the condition of the equipment for signs of shipping damage. If there should be any complaints you should immediately notify the forwarding agent and your nearest Studer distributor.

It is recommended to retain the original packing material because it offers the best protection in case your equipment ever needs to be transported.

2.1.2.2 Adjustments, Repair, Cleaning

- Danger:**  All internal adjustments as well as repair work on this product must be performed by expert technicians!
- Replacing the Supply Unit:**  *The primary fuse is located within the power supply module and cannot be changed. In case of failure, the complete power supply unit must be replaced. Please ask your nearest Studer representative.*
- Cleaning:**  Do not use any liquids to clean the exterior of the unit. A soft, dry cloth or brush will usually do.
 For cleaning the display windows and screens, most of the commercially available window or computer/TV screen cleaners are suited. *Use only a slightly damp (never wet) cloth. Never use any solvent!*

2.1.2.3 USB Sockets

- Important**  ***USB memory devices MUST NOT BE REMOVED from the socket DURING DATA ACCESS – only remove any of them after its LED has stopped flashing in order to avoid data loss!***

2.1.3 Technical Specifications (subject to change without prior notice)

Mic / Line Input Module	Conditions / Details	Value
General Conditions:	Gain Setting 15 dBu \cong 0 dB_{FS} unless otherwise noted.	
Input Impedance	(Electronically Balanced)	3.6 k Ω
Gain	for 0 dB _{FS} (adjustable in steps of 1 dB)	-11 to +75 dB
Maximum Input Level	-11 dB Gain, R _{source} = 600 Ω	+26 dBu
	0 dB Gain, R _{source} = 150 Ω	+15 dBu
Frequency Response	20 Hz to 20 kHz, 40 dB Gain	+0 / -0.9 dB
	30 Hz to 20 kHz, 40 dB Gain	+0 / -0.6 dB
THD + Noise	1 kHz, -1 dB _{FS}	\leq -87 dB
	1 kHz, -9 dB _{FS} (Nominal Level)	\leq -94 dB
	20 Hz to 20 kHz, -30 dB _{FS}	< -102 dB _{FS}
Equivalent Input Noise / Noise Figure (NF)	R _i = 200 Ω , Gain \geq 60 dB	-127.6 dBu / NF \leq 2
Crosstalk	1 kHz	\leq -100 dB
Input Delay		12 samples 250 μ s @ 48 kHz
Common Mode Rejection Ratio (CMRR)	30 Hz to 20 kHz, All Gain Settings	> 46 dB
	1 kHz, -11 dB to +26 dB Gain	60 dB typ.
Line Output Module	Conditions / Details	Value
Output Impedance	(Electronically Balanced)	50 Ω
Frequency Response	20 Hz to 20 kHz	+0 dB / -0.3 dB
THD + Noise	-1 dB _{FS} , 1 kHz	-90 dB
	-30 dB _{FS} , 20 Hz to 20 kHz	-103 dB
Crosstalk	1 kHz	-115 dB
Output Level	R _L \geq 600 Ω ; Globally adjustable with hardware switches (steps: +24, +22, +20, +18, +15, +12, +9, +6 dBu)	+6 to +24 dBm for 0 dB _{FS}
Output Delay		10.4 samples 217 μ s @ 48 kHz
AES / EBU Input / Output Module	Conditions / Details	Value
Input/Output Impedance		110 Ω
Input Sensitivity		min. 0.2 V _{RMS}
Output Level	into 110 Ω	4.0 V _{RMS}
THD + Noise		max. -115 dB
SRC Range		22-108 kHz
Input Delay	$r_{S_IN} > r_{S_OUT}$: $D = \frac{16}{r_{S_IN}} + \frac{32}{r_{S_OUT}}$ [s] $r_{S_IN} < r_{S_OUT}$: $D = \frac{48}{r_{S_IN}}$ [s]	
Power Supply	Conditions / Details	Value
Primary Input Voltage Range	Auto-ranging, with power factor correction (PFC); EN/UL approved. 2 power inlets provided for redundancy.	100 to 240 V AC \pm 10% 50 to 60 Hz
Power Consumption Vista 1	22-Fader Version	220 W typ., 300 W peak
Power Consumption Vista 1	32-Fader Version	190 W typ., 250 W peak
Ambient Conditions	Details	Value
Operating Temperature Range*		0 to 45 $^{\circ}$ C 32 to 113 $^{\circ}$ F
	non-condensing	95%
* Also refer to 'Appendix 1: Air Temperature and Humidity' on page X at the beginning of this manual		
Weights		Value
Vista 1 Console, 22-Fader Version		54 kg
Vista 1 Console, 32-Fader Version		60 kg

2.1.3.1 Dimensions

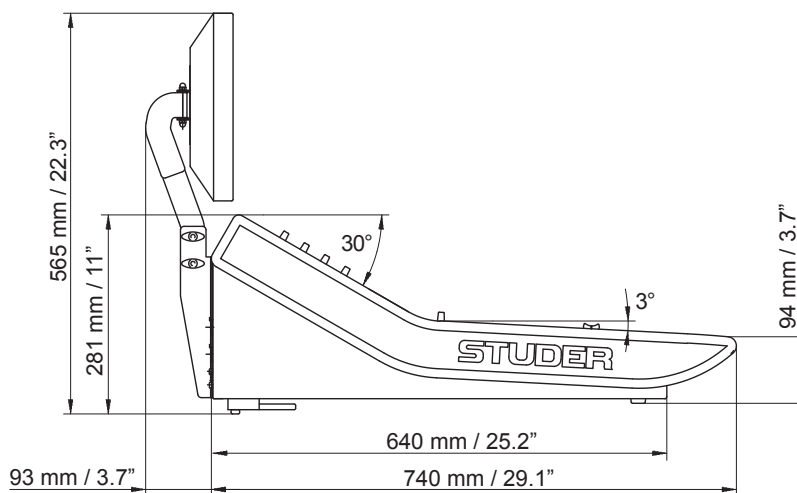
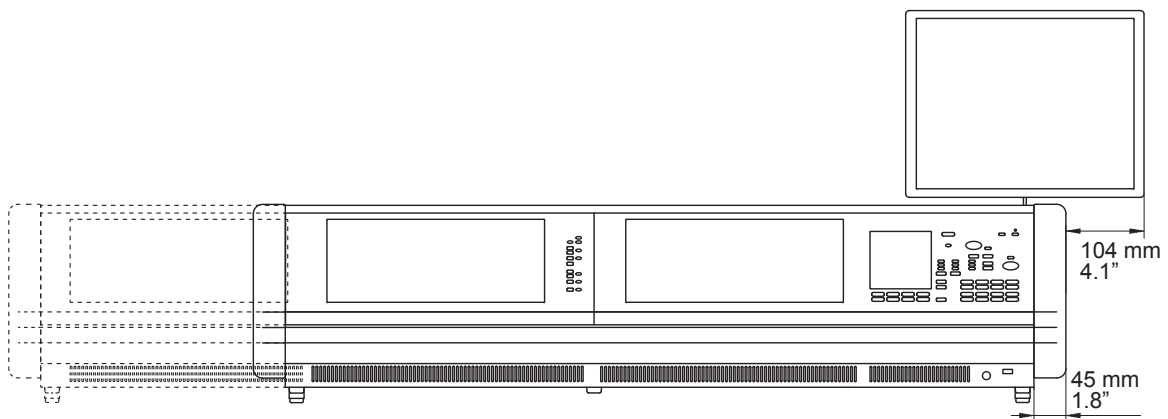
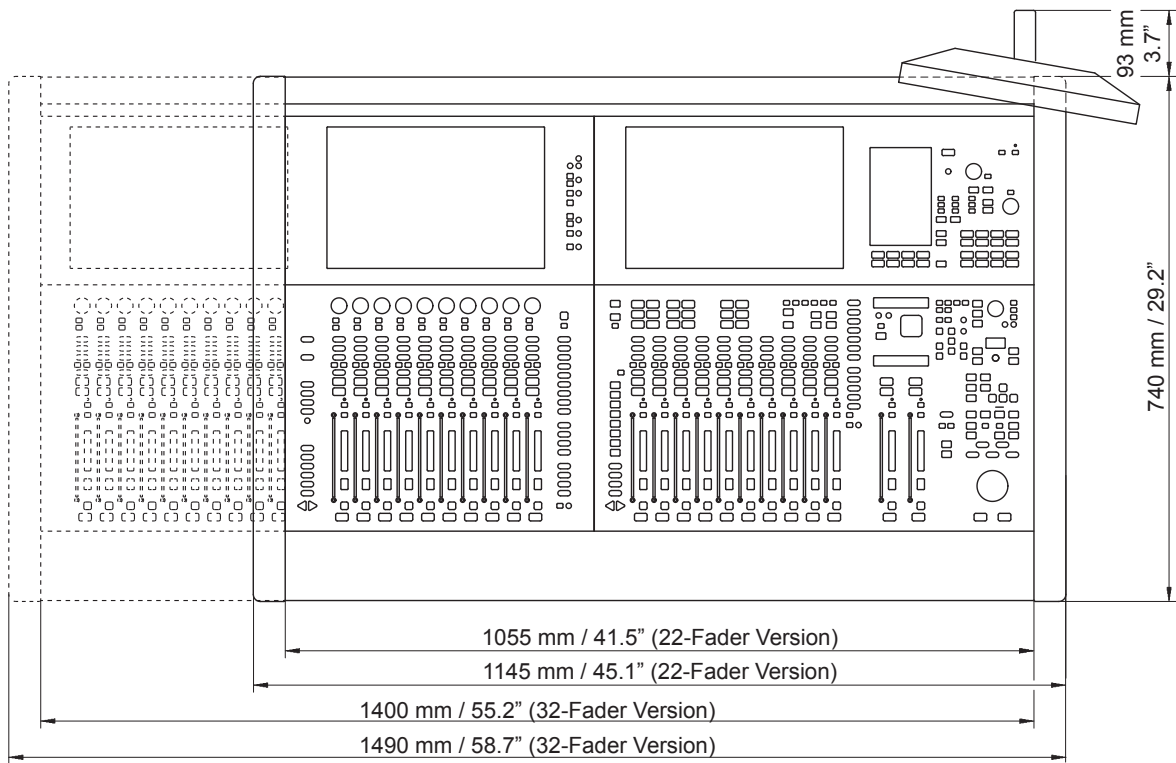

2.1.4 Connectors

2.1.4.1 Rear Panel Connectors

Due to the fact that Vista 1 is an all-in-one console, wiring is somewhat easier since no connection(s) to any external DSP core need to be made. There are six connector areas at the console's rear side.



Connectors dedicated to monitoring and talkback inputs/outputs are somewhat depending on the currently loaded DSP configuration (details on configurations: [chapter 6](#); connection details: [chapter 2.1.5](#)).

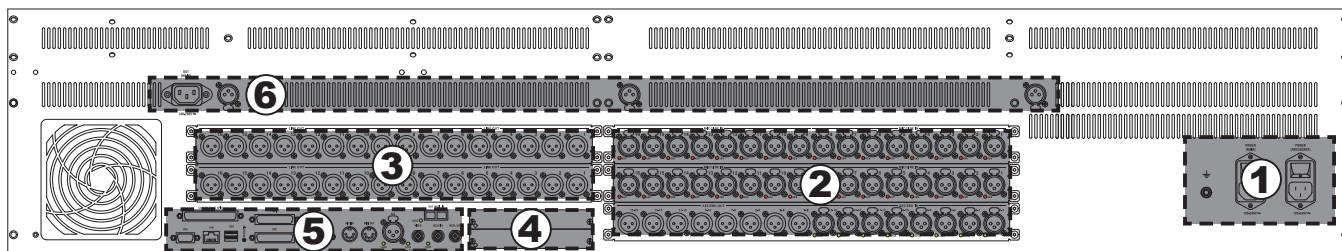

- (1) **POWER (MAIN) and POWER (REDUNDANT)** Mains inputs on IEC320/C13 appliance inlets with integrated power switches. Two separate, wide-range input power supplies are built into the desk for supply redundancy, and \perp Ground terminal with M6 thread.
- (2) **MIC/LINE IN:** 32 analog, electronically balanced microphone/line level inputs on XLR3m connectors; a red LED per input indicates if the 48 V phantom power is switched on, and **AES/EBU IN / AES/EBU OUT:** 8 digital AES/EBU input/output pairs on XLR3m/f connectors; a green LED per input indicates lock status.
- (3) **LINE OUT:** 32 analog, electronically balanced line level outputs on XLR3f connectors.

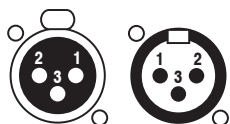

Pin	Signal (Input)	Signal (Output)
1	Screen	Screen
2	In +	Out +
3	In -	Out -

- (4) Two slots for Studer D21m I/O extension cards, accommodating either one double-width or two single-width cards. If an additional Compact Stagebox is connected, an optical or twisted-pair D21m MADI card is used here, matching the MADI HD card in the Compact Stagebox.
- (5) Area of different additional audio, communication and control signal inputs/outputs. For details refer to [chapter 5.1.1](#).
- (6) **OUT (MAIN)** Mains output for the external GC monitor screen on an IEC320/C14 appliance outlet; it is directly connected to the **MAIN** power inlet and so always has the same voltage, and Three XLR3f sockets for connecting gooseneck console lighting (not included). Voltage is 5 or 12 VDC, selectable with an internal jumper.



Pin	Signal
1	n.c.
2	+5 VDC or +12 VDC (factory default: 12 V), 1 A max. per socket
3	GND

2.1.4.1.1 Connector Area 5

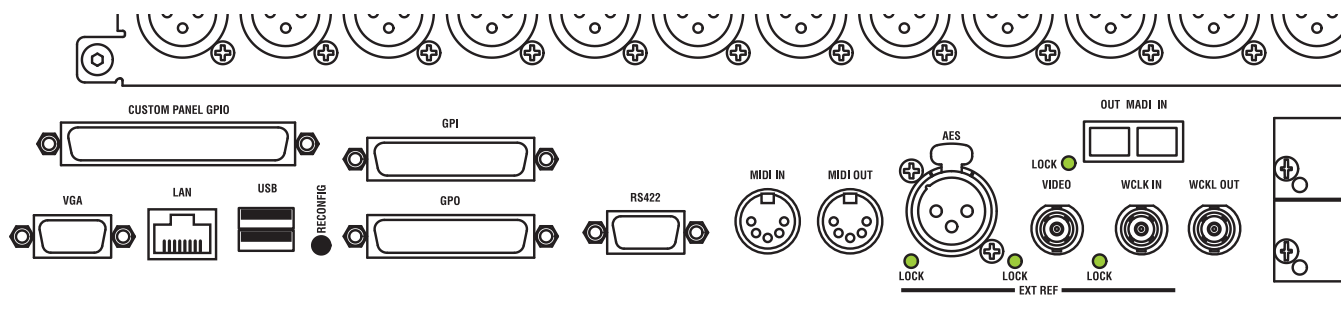

VGA Connector for the external graphical controller screen.

LAN Ethernet port for communication with the console’s control system.

USB Dual USB port for connecting an external keyboard (and a mouse, if required) or a memory device for backup purposes to the console’s control system. These ports are equivalent to the **DATA** USB port on the desk.



A USB memory device MUST NOT BE UNPLUGGED DURING DATA ACCESS – only remove it after its LED has stopped flashing in order to avoid data loss!

RS422 9-pin D-type connector (female, UNC 4-40 thread) for RS422 communication with the console’s control system (COM 4).

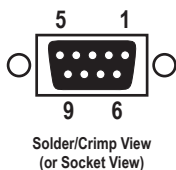

Pin	Signal	Pin	Signal
1	n.c.	6	n.c.
2	RX-	7	RX+
3	TX+	8	TX-
4	n.c.	9	n.c.
5	n.c.		

MIDI IN / MIDI OUT MIDI control input/output on MIDI-standard 5-pin DIN sockets, for use with external MIDI communication from the Cue List, such as external reverb preset control.

EXT REF External clock reference inputs:

AES AES/EBU on an XLR3f socket

VIDEO Video reference signal input, termination 75 Ω or hi-Z selectable with DIP switch S2-1 on the Central PCB near the connector (*switch off = hi-Z, this is the factory default setting*)

WCLK IN Word Clock reference signal input, termination 75 Ω or hi-Z with DIP switch S2-4 on the Central PCB near the connector (*switch off = hi-Z; this is the factory default setting*)

WCLK OUT Word Clock signal output for operation with the desk’s internal reference. Output impedance 75 Ω.

MADI Optical, multimode 64 I/O MADI port (62.5 μm/125 μm SC connector). This interface is intended as a multi-track I/O. *It cannot be used for connecting a stagebox since no control signals for preamp remote control are implemented on this interface.*

RECONFIG The recessed **RECONFIG** key must be pressed after having changed the I/O module or D21m card configuration.

CUSTOM PANEL GPIO

(37-pin D-type, female, UNC 4-40 thread) for wiring the 12-key **CUSTOM PANEL** desk section for external tasks such as signaling. The 12 ‘Switch’ control outputs are open collectors pulling to ground if active. They are controlled by the **CUSTOM PANEL GP 1-12** desk keys. The 12 ‘LED’ control inputs are dedicated to illuminating the corresponding keys. The function of GPO 7-12 can be modified by pulling pin 34 to ground in such a way that they are controlled by software (configurable). The **GP 7-12** desk keys will then have no function.

Inputs

The two control input groups (LEDs 1-6 and 7-12) are independent. They may be used either with the internal +5 V DC supply voltage, or with external voltages of +5...+24 V DC; selection is made with DIP switch S184-1 and -2 (refer to the tables above). In both cases they are activated by pulling the LED X input to ground, either to the internal one or the one of the external supply, respectively.

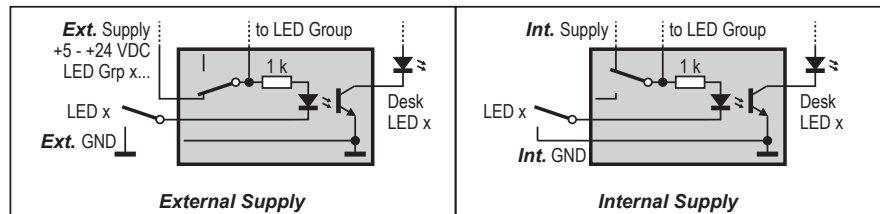

Outputs

The control outputs (activated by **CUSTOM PANEL GP 1-12** desk keys, or desk keys **GP 1-6** and internal GPO 7-12) are open-collector outputs pulling to GND if active, with either momentary or latching action; this is selected with DIP switches S184-3 and -4 and S185 (refer to the tables below). The +5 V DC supply voltage (or an external supply of up to 24 VDC) together with the open collector outputs may be used to generate an output signal for relays, LEDs etc.

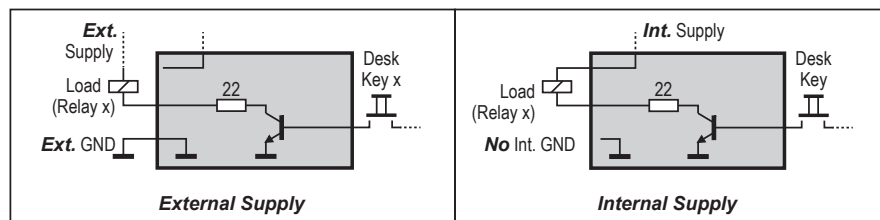

Current must not exceed 300 mA per output. Please make sure to use appropriate current-limiting resistors in series if necessary. When using an external supply, connect its ground terminal to the internal ground (pins 1 or 19).



*The total current supplied by the VCC (+5 V DC) pin of the **CUSTOM PANEL GPIO** connector must not exceed 400 mA.*

Options are set by DIP switches on the on the Central PCB:

DIP SW	ON	OFF
S184-1	Int. Supply f. LEDs 1-6	Ext. Supply f. LEDs 1-6, 5-24 V DC
S184-2	Int. Supply f. LEDs 7-12	Ext. Supply f. LEDs 7-12, 5-24 V DC
S184-3	Switch 5, 6 momentary action	Switch 5, 6 toggling action
S184-4	Switch 5, 6 momentary action	Switch 5, 6 toggling action
S184-5	Switch 1-4 not active at power-up	Switch 1-4 active at power-up
S184-6	Switch 7-10 not active at power-up	Switch 7-10 active at power-up
S184-7	Switch 5, 6 not active at power-up	Switch 5, 6 active at power-up
S184-8	Switch 11, 12 not active at power-up	Switch 11, 12 active at power-up

DIP SW	ON	OFF
S185-1	Switch 1 momentary action	Switch 1 toggling action
S185-2	Switch 2 momentary action	Switch 2 toggling action
S185-3	Switch 3 momentary action	Switch 3 toggling action
S185-4	Switch 4 momentary action	Switch 4 toggling action
S185-5	Switch 7 momentary action	Switch 7 toggling action
S185-6	Switch 8 momentary action	Switch 8 toggling action
S185-7	Switch 9 momentary action	Switch 9 toggling action
S185-8	Switch 10 momentary action	Switch 10 toggling action

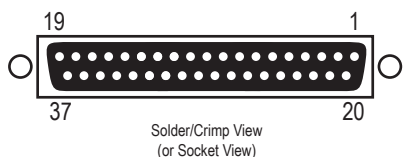

Pin	Signal	Pin	Signal
1	GND	20	Switch 1
2	LED 1	21	Switch 2
3	LED 2	22	Switch 3
4	LED 3	23	Switch 4
5	LED 4	24	Switch 5
6	LED 5	25	Switch 6
7	LED 6	26	Switch 7 (or GPO 7*)
8	LED 7	27	Switch 8 (or GPO 8*)
9	LED 8	28	Switch 9 (or GPO 9*)
10	LED 9	29	Switch 10 (or GPO 10*)
11	LED 10	30	Switch 11 (or GPO 11*)
12	LED 11	31	Switch 12 (or GPO 12*)
13	LED 12	32	n.c.
14	n.c.	33	n.c.
15	n.c.	34	Switch 7-12 / *GPO 7-12 selection
16	n.c.	35	n.c.
17	n.c.	36	Ext. Supply f. LEDs 1-6, 5-24 V DC (S184-1 is OFF)
18	Ext. Supply f. LEDs 7-12, 5-24 V DC (S184-2 is OFF)	37	VCC (+5 V, 400 mA max.)
19	GND		

GPIO Inputs The control inputs (GPI Xa/b) are completely independent and electrically isolated. They may be used either with the internal +5 V DC supply voltage, or with external voltages of 5...24 V DC, regardless of the polarity.

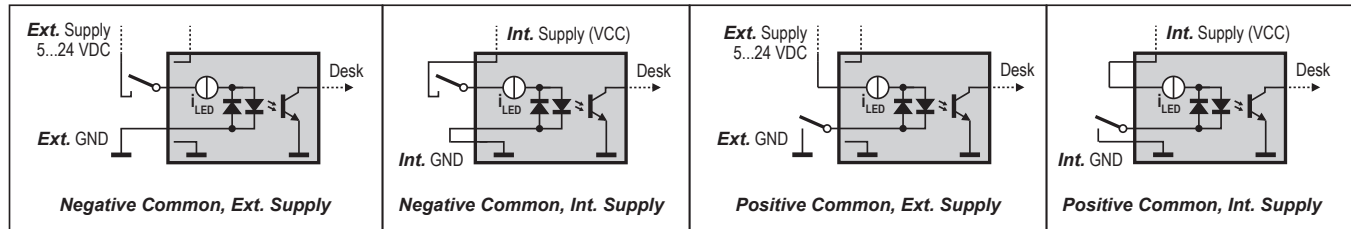

GPI 1-8 (25-pin D-type, female, UNC 4-40 thread)

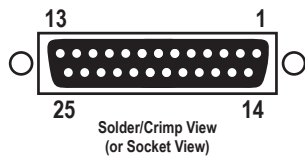

Pin	Signal 'GPI 1-8'	Pin	Signal 'GPI 1-8'
1	GPI 1a	14	GPI 1b
2	GPI 2a	15	GPI 2b
3	GPI 3a	16	GPI 3b
4	GPI 4a	17	GPI 4b
5	GPI 5a	18	GPI 5b
6	GPI 6a	19	GPI 6b
7	GPI 7a	20	GPI 7b
8	GPI 8a	21	GPI 8b
9-13	GND (0 V)	22-25	VCC (+5 V / 600 mA max.)

GPIO Outputs The control outputs (GPO Xa/b) are completely independent and electrically isolated relay contacts, closed if active. They may be used either with the internal +5 V DC supply voltage (VCC) and the internal ground, or with external voltages within the limits given in the table below. So when using an external supply, it is irrelevant whether the load is connected between + or GND and one of the relay contacts, regardless of the polarity of the external supply voltage.

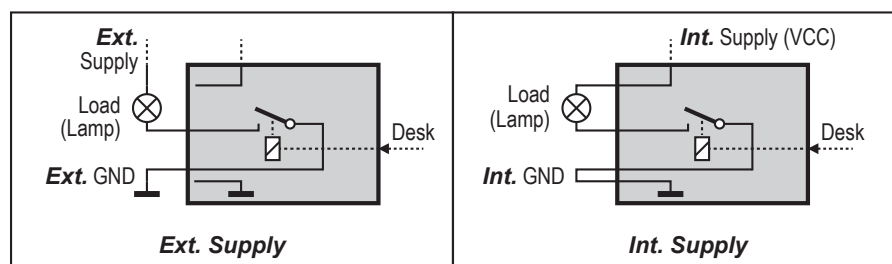

	Contact Rating (max. Values)
Switching Power	62.5 VA / 30 W
Switching Voltage	50 V AC or DC
Switching Current	1 A
Contact Resistance	max. 100 mΩ at 6 V DC / 1 A

The +5 V DC supply voltage and the ground (GND) terminals, together with the relay contacts, may be used to generate an output signal. Using an external supply together with the relay contacts is possible as well.



The total current supplied by all VCC (+5 V DC) pins of the GPI / GPO connectors must not exceed 400 mA.

GPO 1-8 (25-pin D-type, female, UNC 4-40 thread)

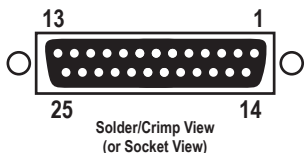

Pin	Signal 'GPO 1-8'	Pin	Signal 'GPO 1-8'
1	GPO 1a	14	GPO 1b
2	GPO 2a	15	GPO 2b
3	GPO 3a	16	GPO 3b
4	GPO 4a	17	GPO 4b
5	GPO 5a	18	GPO 5b
6	GPO 6a	19	GPO 6b
7	GPO 7a	20	GPO 7b
8	GPO 8a	21	GPO 8b
9-13	GND (0 V)	22-25	VCC (+5 V / 600 mA max.)

2.1.4.2 Front Connectors

DATA USB Socket In the **SYSTEM** Area of the control bay; for data backup and restore purposes or, e.g., connecting a USB keyboard.

Jingle Player USB Socket Under the desk’s hand rest at the right-hand side; *reserved for the integrated jingle player only*. This USB socket may, of course, also be used for an external hard drive. If this drive takes its power supply from the USB socket, its consumption must not exceed 500 mA. *Supplying the unit externally is strongly recommended.*



A USB memory device MUST NOT BE UNPLUGGED DURING DATA ACCESS – only remove it after its LED has stopped flashing in order to avoid data loss!

Headphones Socket Under the desk’s hand rest at the right-hand side; this is a standard 6.35 mm TRS headphones socket. Recommended headphones impedance 75 - 300 Ω. Headphones with higher and lower impedances may be used but will produce reduced listening level.

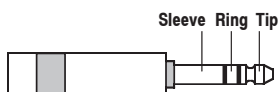

Pin	Signal
Tip	Left Channel
Ring	Right Channel
Sleeve	Screen/GND

2.1.5 Monitoring/Talkback Inputs/Outputs

The monitoring and talkback input and output assignment is not fixed but depends on the currently loaded desk configuration and on any personal changes made to it later.

The next two paragraphs show the monitoring/TB I/O factory defaults. Please note that the range of configuration templates will grow with time, and there also may be some future changes and modifications to these default assignments.

2.1.5.1 'Vista 1 Mono/Stereo/FOH/Monitor' Configuration Templates

The monitoring and TB I/O connector assignment for the mono, stereo and PA configurations is identical, according to the information given below.

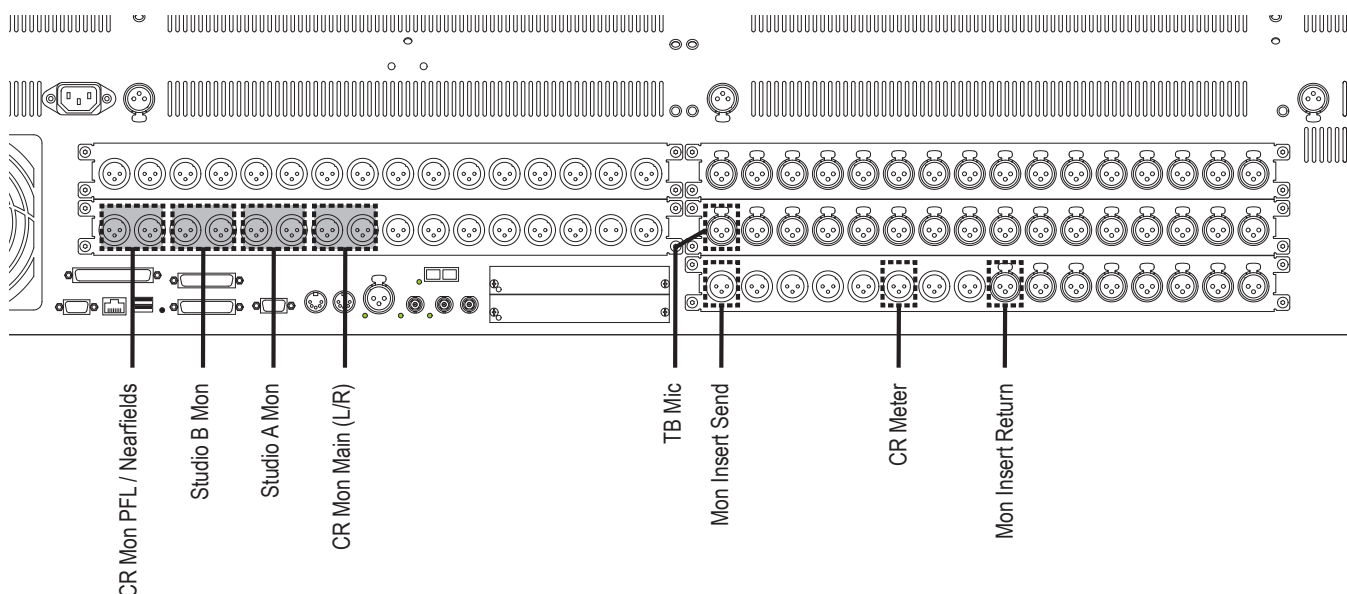

	Format	Analog I/O	Digital I/O	
CR Mon Main	stereo	LineOut 25, 26	-	OUTPUTS
CR Mon PFL/Nearfields	stereo	LineOut 31, 32	-	
CR Meter	stereo	-	AES Out 5/6 (inactive)	
Studio A Mon	stereo	LineOut 27, 28	-	
Studio B Mon	stereo	LineOut 29, 30	-	
Studio A Meter		-	-	
Studio B Meter		-	-	
Mon Insert Send	stereo	-	AES Out 15/16 (inactive)	
Mon Insert Return	stereo	-	AES In 15/16 (inactive)	INPUTS
TB Mic	mono	Mic/Line In 32 (inactive)	-	

Items marked by *(inactive)* in the table and in white in the drawing above are preconfigured in the `mon.ini` file; they can be activated by deleting the corresponding comment marks.

2.1.5.2 'Vista 1 Surround' Configuration Template

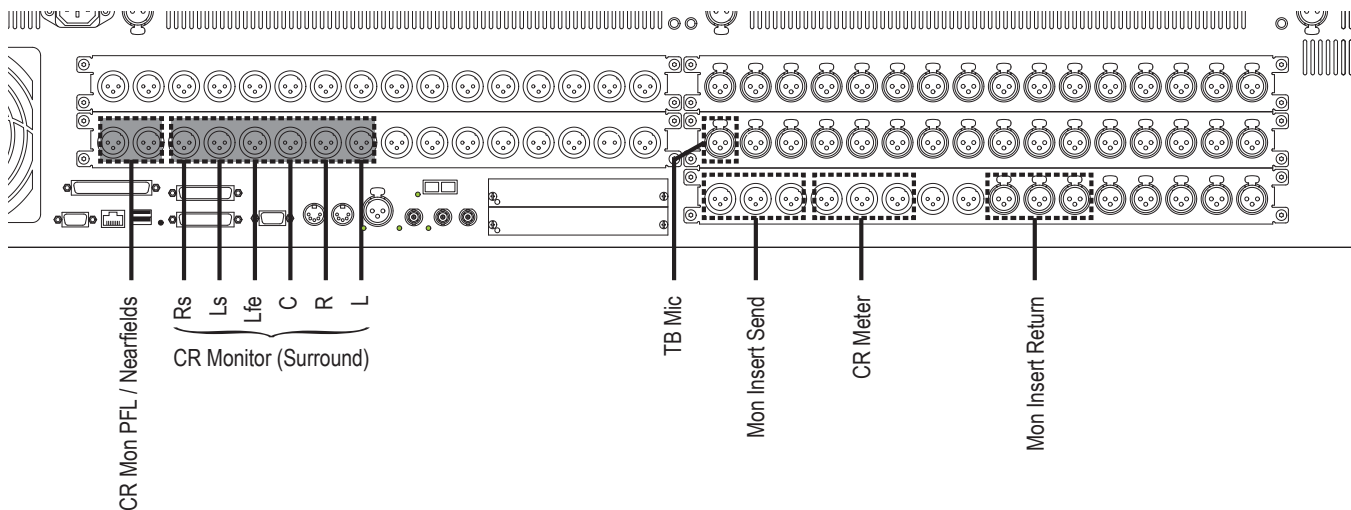

	Format	Analog I/O	Digital I/O	
CR Mon Main	5.1	LineOut 25-30	-	OUTPUTS
CR Mon PFL/Nearfields	stereo	LineOut 31, 32	-	
CR Meter	5.1	-	AES Out 5-10 (inactive)	
Studio A Mon	stereo	-	-	
Studio B Mon	stereo	-	-	
Studio A Meter		-	-	
Studio B Meter		-	-	
Mon Insert Send	5.1	-	AES Out 11-16 (inactive)	
Mon Insert Return	5.1	-	AES In 11-16 (inactive)	INPUTS
TB Mic	mono	Mic/Line In 32 (inactive)	-	

Items marked by (inactive) in the table and in white in the drawing above are preconfigured in the mon.ini file; they can be activated by deleting the corresponding comment marks.

2.2 Desk Operation

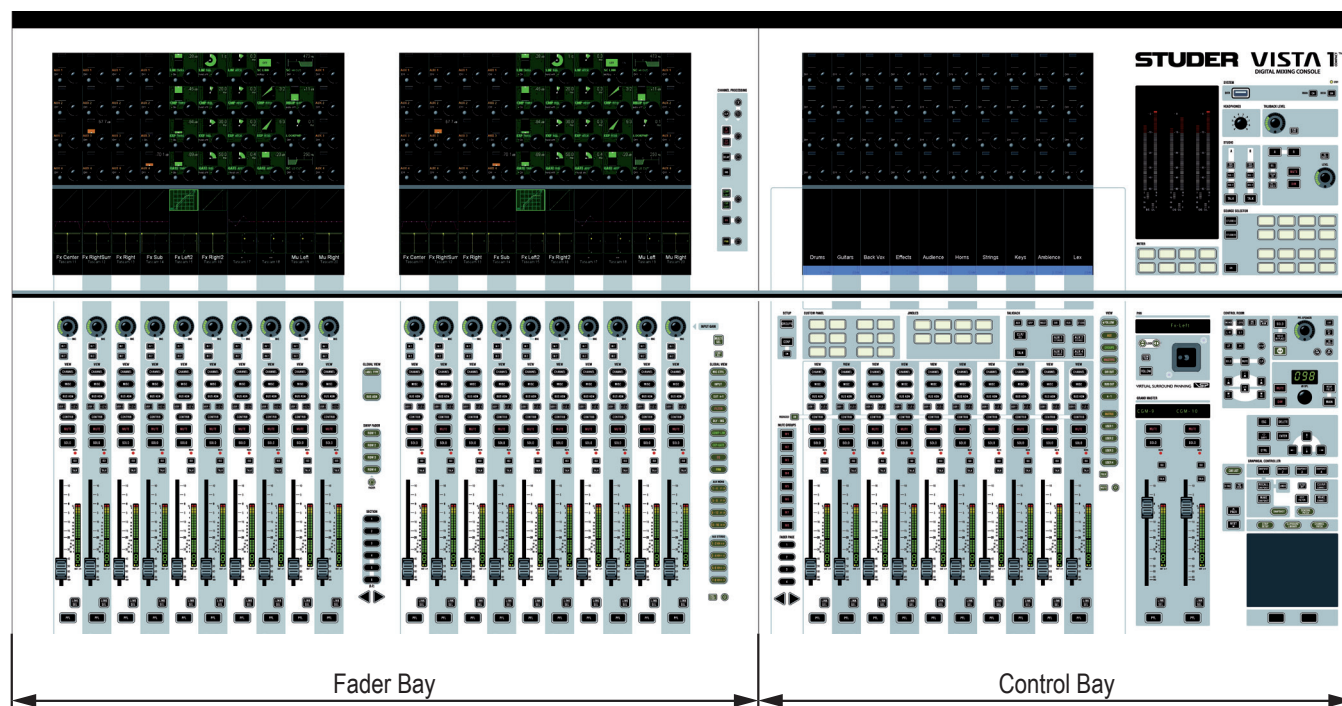

The desk consists of two types of bays: From one to two fader bays (ten faders each), and one control bay (ten faders plus two ‘grand master’ faders). For compactness, two fader bays are combined in a single fader bay module, as shown above. This is the layout of a 32-fader console. The 22-fader version just has one 10-fader bay. Every bay features a Vistronics screen with 40 rotary encoders in its upper part and a touch screen surface below them.

The fader bays contain the console channel strips with rotary controls, faders, keys, and meters. Ten strips are located next to each other in one bay. They may be assigned to any DSP channel.

The control bay hosts the global desk operation controls, such as monitoring, talkback, joystick and touchpad. It can also be used as fader bay in order to control any DSP channel.

The complete electronics – control system, power supplies, I/O and digital signal processing – are contained in the desk. An additional TFT screen is mounted on the rear of the desk in order to display the ‘Graphical Controller’ windows (described in [chapter 4](#)). The screen is attached to the desk at the right of the console.

- ⌚ Each key marked with this symbol can be activated either momentarily or latching. Pressing this key for a short time will make it latching. Holding it down for a longer period of time will reverse its function automatically upon key release.

2.2.1 Vistonics® Operation / Local Views

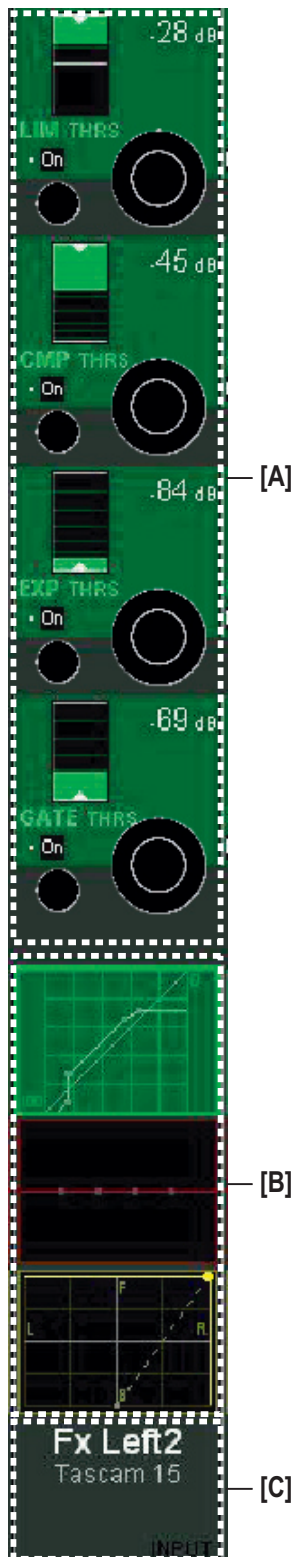

[A] ⊕ Vistonics Rotary Control Area

Each rotary control is grouped with a key to form a control element. These control elements are sometimes used in a channel-related manner, dedicating four of the control elements to each channel strip; sometimes, neighboring channels are used in order to show a complete parameter set of one single channel. This is the case when touching any graphical display of EQ, dynamics, or pan, but also when activating **VIEW: MISC** or **VIEW: CHANNEL**.

[B] ⊕ Vistonics® Touch Screen Area

Graphical indication of dynamics, equalizer and pan. Touching the graphics will open up all corresponding parameters on the rotary control area. This section is also able to display bus assignment. Two modes are available: Bus assignment as a 'bubble view' to give an overview over the whole console, or bus assignment of a specific channel (one per bay). The graphical pan display may vary depending on the configured panning function or format. (2-Ch Stereo Pan, Multi-format Pan, VSP).

[C] Generic Display Area

This area is used to display all sorts of information. The following is continuously displayed:

- *Inherited label* (top line). This corresponds to the *device label* of the connected source (can be edited in the GC's global patch window). This label is normally changing between sessions (e.g. 'Lead Vocal').
- The second line normally displays the *device label*, but may be changed to *fixed channel label* by pressing **GLOBAL VIEW: LABEL TYPE**. The displayed label then toggles between: channel number (also referred to as *fixed label*, e.g. 'Inp m 1'), *user label* (also referred to as *device label*, e.g. 'Tascam Track 1'), or it shows the *2nd layer label* with its real time meter next to it (see [chapter 2.2.6.11](#) for more details). This last option is only available if 'two layer mode' is activated in the Graphical Controller.
- Indication of channel type by color coding of the lower half as well as writing the type in the bottom right corner.

The following information pops up when appropriate:

- Fader value in dB, when touched (or 'held' in dynamic automation mode)
- Graphical representation of current setting and previewed snapshot at the same time.
- Snapshot filter mode of the fader. (TRIM or ISO). A solid yellow background of the word ISO indicates that the whole channel is isolated from snapshot recalls. In case the word is written only in yellow letters with black background, this indicates that only parts of this channel are isolated from snapshot recall.
- N-X indication and bus number.

Touching the upper half (for input channels, multi-track input channels, multi-track monitor channels): Opens the GC's General Patch window, showing the *channel input* position of the selected channel..

Touching the lower half (for all channels): Opens the GC's General Patch window, showing the *direct output* position of the selected channel.



- ⊕ **VIEW: CHANNEL** Brings up a view of all control elements of this channel besides dynamics, equalizer, and pan, covering the whole Vistonics rotary control area.

- ⊕ **VIEW: MISC** View Selection of DYNAMICS, EQ, and PAN Controls
Brings up a view of selected control elements out of dynamics, equalizer, and pan, covering the whole Vistonics rotary control area. The **VIEW CHANNEL** and **VIEW MISC** keys form a sort of ‘central assign panel’ function.

- ⊕ **VIEW: BUS ASN** Brings up the bus assign view of one channel, covering the whole touch screen area.
When showing the bus assignment of a single channel, the assignment can be changed by touching the bus number. It is also possible to clear all bus assignments of a type by pressing the corresponding key on the touch screen.

2.2.2 Fader Area

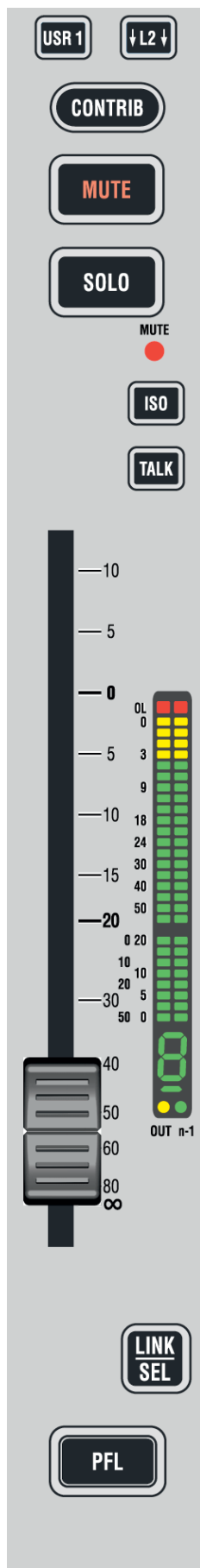

Control Group

- USR 1** Key for programmable user- or application-specific functions (such as fader start, fader ramps (audio-follows-video), switching to an alternate n-x output signal, user specific functions etc.).
- ⊕ **MUTE** Mutes the corresponding channel. The **MUTE** LED indicates when the channel is muted by a SOLO IN PLACE function or by a mute group.
- ⊕ **SOLO** Depending on the setting of **SOLO**, and **SOLO IN PLACE** keys, this activates the SOLO, or SOLO IN PLACE function of the corresponding channel. The solo signal is always inserted into the control room monitoring path as soon as at least one channel is active.
 As a standard the SOLO works in non-additive mode. This means that pressing a second SOLO button will automatically release the first one. However, additive mode can be entered by press-and-hold at least two SOLO buttons at the same time. From then on any other SOLO is added without canceling the first ones. Non-additive mode is re-activated by canceling all active SOLOs.
- ⊕ **ISO** The whole channel may be filtered from snapshot recalls by pressing this key. It is also possible to isolate only certain elements of a channel, such as the EQ. This is done by pressing and holding the **ISO** key while pressing the corresponding audio key in the central 'Channel Processing' area. Pressing e.g. the **EQ** on/off key will put the whole EQ into ISOLATE mode. Touching a rotary encoder will put just that rotary into ISOLATE mode, indicated by a yellow 'I' or – if one of the Vistonics keys is selected – just by changing its color to yellow. It is also possible to e.g. open up the EQ view on the Vistonics screen and select only one single parameter of the EQ to go into ISOLATE. If one of the EQ parameters is isolated, but not the whole EQ, the **EQ** on/off key becomes half-lit while pressing **ISO**. If the 'Enable Trim Mode' option in the Static Automation Options page is active, the status of the elements doesn't only toggle between READ and ISOLATE, but also goes to a red 'T' (TRIM). On Vistonics keys this status is indicated simply by changing the button's label color to red.
 The **ISO** key is fully lit, in case the *whole* channel is currently isolated from snapshot recalls. This state is accompanied by the word ISO with solid yellow background in the Generic Display Area.
- ⊕ **TALK** Activates talkback to the direct output of this channel and, if applicable, to the n-1 bus output. In case this channel is participating an off-air conference at this time, talkback is activated to all members of the conference.
- Control Group** 7-segment display indicating the control group to which this channel is assigned (this is a function similar to 'VCA groups' known from analog mixing consoles).
- ⊕ **PFL** Activates pre-fader listening mode. Signal is fed to the near-field monitoring outputs as standard, but can be inserted into the main control room monitors by pressing CR INJECT.
 As a standard the PFL works in non-additive mode. This means that pressing a second PFL button will automatically release the first one. However, additive mode can be entered by press-and-hold at least two PFL buttons at the same time. From then on any other PFL is added without cancelling the first ones. Non-additive mode is re-activated by cancelling all active PFLs.

2.2.2.1 Channel Meters

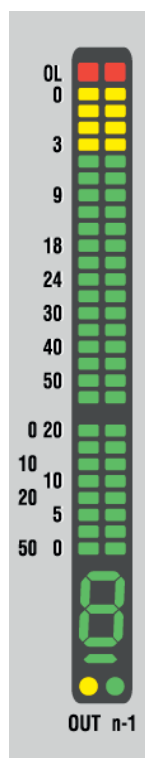

Each channel strip hosts a tri-coloured two-channel LED bargraph meter, indicating various levels of the corresponding channel. The lower part of the meter is reserved to show gain reduction in case compressor/limiter (right side) or expander/gate (left side) is active. One LED element stays on permanently if any of the dynamics processing blocks is switched on.

The upper part is showing levels. If a mono signal is displayed, both ‘channels’ are linked and show the same display. A temporary peak hold helps finding current peak levels. A separate red element on the very top indicates OL, i.e. overload. The headroom of the meters (i.e., the point where they change from green to yellow) can be adjusted within $-25 \text{ dB}_{\text{FS}}$ and $-5 \text{ dB}_{\text{FS}}$ using the graphic controller screen (Option – Meter/Generator menu).

The following levels may be displayed and indicated using the two dots below the meter:

- Channel input level (post input processing): left dot dark
- Channel post-fader level: left dot green
- Channel direct output level (if patched to an output interface only): left dot yellow.

In case the channel is an ‘n-1 owner channel’, the right half of the LED bargraph may show the n-x output level. This is indicated by a green dot above the ‘n-1’ label. Since the meters cannot show two channels of a stereo channel anymore in this mode, they will show the maximum of left and right channel at this time. Therefore: Left part of meters shows ‘max of left/right channel level’, right part shows ‘max of left/right n-1 output level’.

Control Group Indicator

The 7-segment display indicates the control group to which this channel is assigned (this is a function similar to ‘VCA groups’ known from analog mixing consoles).

2.2.2.2 Channel Selection

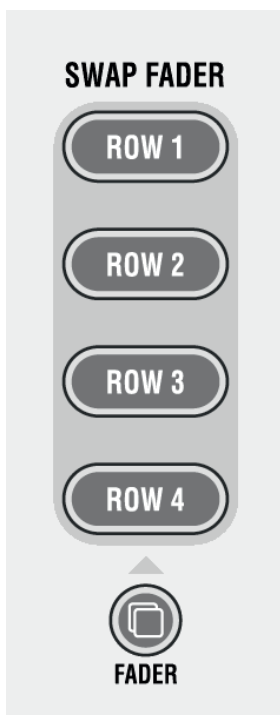

⊕ MULTI SEL

Used to make multiple selections; acts similar as the ‘Ctrl’ key on a PC keyboard.

LINK ALL

Links all channels of one type together (‘Super Gang’) mainly for setup purposes. After **LINK ALL** has been pressed, all **LINK / SEL** keys are half-lit, waiting for the channel type to be defined (for linking). *Such a ‘Super Gang’ also includes channels which are currently not visible on the surface!*

A gang is canceled by pressing any **LINK / SEL** key on the desk.

SWAP FADER: ROW 1...ROW 4

Swaps the current fader value and the **MUTE** key onto the selected rotary row, if the current global view on that row has a level control with the same range as the fader (–90...+10 dB), while the value of that row is temporarily displayed on the faders. The function is canceled when pressing the swap key again or when activating any other swap function.

☞ FADER

Pressing this key will make the keys **ROW 1...4** half-lit. All fader and mute values of the current gang will be copied onto the control element shown on the corresponding rotary row, if there is an appropriate parameter visible; e.g. AUX level or Direct Out Level. If the fader is copied onto a stereo AUX, the left/right pan value is also copied along with the fader and mute values.

Note: If the direct outputs of the input channels are connected to a multi-track recorder, it might be desirable to have the fader values copied over onto the direct output level controls before starting a recording. If the faders are moved, e.g. during a live transmission, the levels on the multi-track recorder will remain constant.

LINK / SEL

This key is used to select channels in different situations:

- Select a channel for switching audio processing such as EQ in and out.
- Select a channel for copying pasting audio values.
- Select a channel for ‘channel patch view’ on the Graphic Controller
- Select a channel for joystick assignment (PAN)
- Select/de-select a channel from a control group when in CGM setup mode
- Select a channel type when linking all channels of the same type.

Pressing two of these keys simultaneously will form a ‘gang’ between the two. With **MULTI SEL** it is also possible to select channels that are separate from each other.

All the members of a gang act together like one channel. Any change to one of the members is performed to all of them. See [chapter 1.1.3](#) for details.

2.2.3 Global Views



The **GLOBAL VIEW** keys allow changing the view on the fader bays or across the whole console if **FOLLOW** is active on control bay. If the control bay is *not* in **FOLLOW** mode, these keys will only change the views on the two fader bays.

- ⊕ **GLOBAL VIEW: MIC CTRL**
- ⊕ **GLOBAL VIEW: INPUT** (gain)
- ⊕ **GLOBAL VIEW: OUT n-1**
- ⊕ **GLOBAL VIEW: FILTER**
- ⊕ **GLOBAL VIEW: DLY - INS**
- ⊕ **GLOBAL VIEW: COMP - LIM**
- ⊕ **GLOBAL VIEW: EXP - GATE**
- ⊕ **GLOBAL VIEW: EQ**
- ⊕ **GLOBAL VIEW: PAN**
- ⊕ **GLOBAL VIEW: AUX MONO ...**
- ⊕ **GLOBAL VIEW: AUX STEREO...**

The different views will only cover the rotary controls that are necessary to display the corresponding function. The others will still show their previous function. Pressing **GLOBAL VIEW...** a second time will blank all other rotary controls for improved clearness.

Example: AUX 1-4 are shown on rotary controls 1-4. The user presses **GLOBAL VIEW: FILTER**, and the rotary controls 1-2 will now show the input filters (rotary controls 3-4 are still showing AUX 3 and 4). When the user presses **GLOBAL VIEW: FILTER** again, the rotary controls 3-4 will be blanked.

⊕ **PRE / POST – AUX View Modifier**

When auxiliaries are shown on the rotary controls, they have an on/off key next to the rotary control. By pressing the **PRE / POST** modifier key, the key next to the AUX rotary control will change its function to pre-/post-fader.

⊕ ↑ (Shift)

Changes the meaning of the **GLOBAL VIEW: AUX...** keys to select the upper half of auxiliaries: **AUX MONO 17-32** or **AUX STEREO 9-16**. However, depending on the currently loaded configuration, there may be less AUX busses available; so some of the AUX keys might be without function.

Note: When pressing **GLOBAL VIEW: EQ** while the ↑ (Shift) key is active, there is an alternate EQ view. Then the four rotaries will show only the two mid bands, but allow access to these two bands' frequency and gain setting. Also, if ↑ (Shift) is active, pressing the local views **VIEW CHAN** and **VIEW MISC** will exclusively show all auxiliaries of the corresponding channel. Therefore it is possible to see up to 40 mono and 20 stereo auxiliaries of a channel when pressing **MISC** and **CHANNEL** on a channel strip. This is useful when working with multiple auxiliary and matrix buses.

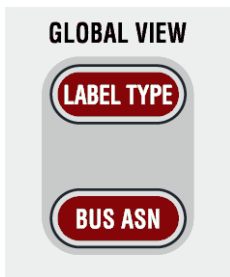

GLOBAL VIEW: LABEL TYPE

Changes the label type of the second line in the generic display area to show:

- Device label (also referred to as user label)
- Fixed label (shows the input channel's number)

GLOBAL VIEW: BUS ASN

Activates a 'bubble view' of the bus assignment throughout the whole console. If the bay is locked, only the corresponding bay is affected.

2.2.4 Central Channel Processing Keys



This set of keys is used to switch processing on/off within one or several channels. It also hosts keys to copy and paste settings between channels or between the clipboard library and channels. As a standard the user selects a channel first (pressing **LINK / SEL**) and then switches e.g. EQ On. If a gang is made, the switching will happen on all member channels of the gang. As soon as a local view change is done on another channel (e.g. touching the EQ graphic in order to open the EQ view locally on a Vistonics screen), these set will become active for that specific channel. After closing the EQ view, the set is again dedicated to the channel(s) with **LINK / SEL** active. If several views are opened on the Vistonics screens, the key set is following the principle of 'last wins'. Wherever a view has been opened last the **CHANNEL PROCESSING** key set is active.

Example 1: The user wants to activate the compressor/limiter in channel 10. In order to do that he either presses **LINK / SEL** on channel 10 first, followed by the **COMP / LIM** key on the central channel processing keys. Or he may open any local views such as touching the dynamics curve on the touch screen (therefore opening the view of the dynamics section) and then presses **COMP / LIM** on.

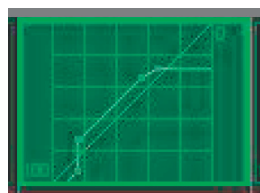

Example 2: The user wants to switch on a low cut filter on channels 1-20. The fastest way to do that will be to first create a gang of the channels 1 to 20 (press-hold **LINK / SEL** on channel 1, followed by **LINK / SEL** on channel 20). This will assign the central processing keys to the whole gang, so the user can now press **COMP / LIM** on and have it activated on all ganged channels together. Finally the user may want to delete the gang by pressing any **LINK / SEL** key.



- ⊕ HI CUT
- ⊕ LO CUT
- ⊕ DELAY
- ⊕ INS
- ⊕ COMP / LIMIT
- ⊕ EXP / GATE
- ⊕ EQ
- ⊕ PAN

Audio processing functions on/off; if lit, the corresponding audio function is activated. If dark, the function is bypassed. For more details about functions and their parameters refer to [chapter 3](#)).

☞ (Copy/Paste)

Dedicated to each audio function, these keys act as copy (first step) and paste (second step) at the same time. The philosophy of using the central key set for copying and pasting is the same as when switching processing on and off. First select source channel, press copy/paste of the corresponding function, then select destination channel and press the same copy/paste ☞ key again in order to paste into this channel.

After having copied the value of the source channel into the internal clipboard (first press), the source channel key is fully lit while all possible destination channels are half-lit (see this after changing **LINK / SEL**). This guides the user to select the destination channel efficiently. After having selected one of them as destination key (second press), the copy/paste function is terminated. Nevertheless there are several ways to paste the clipboard value to multiple channels:

- Create a gang and paste the value into one of the members
- Hold **MULTI SEL** before pasting to channels of your choice.

Example 1: The user wants to copy the EQ settings of channel 8 into channel 10.

- 1 Press **LINK / SEL** of channel 8 – or open e.g. the EQ view on channel 8 by pressing the EQ graphics on the touch screen. Alternatively any view of channel 8 could be opened, e.g. by touching the dynamics or pan graphics – or selecting **CHANNEL** or **MISC** view on that channel.
- 2 Press Copy/Paste key next to EQ, located on central **CHANNEL PROCESSING** keys.
- 3 Press **LINK / SEL** of channel 10 – or open e.g. the EQ view on channel 10 by pressing the EQ graphics on the touch screen. Alternatively any view of channel 10 could be opened, e.g. by touching the dynamics or pan graphics – or selecting **CHANNEL** or **MISC** view on that channel.
- 4 Press Copy/Paste key next to EQ, located on central **CHANNEL PROCESSING** keys.

Example 2: The user wants to copy a low cut filter from channel 1 into channels 11-20.

- 1 Select channel 1 by any of the ways described in example 1.
- 2 Press Copy/Paste ☞ key.
- 3 Create a gang between channels 11 and 20 by press-and-hold **LINK / SEL** on channel 11, then press **LINK / SEL** on channel 20.
- 4 Press Copy/Paste key again.
- 5 Delete the gang by pressing any **LINK / SEL** key.



⇧ A (Copy/Paste All)

As ⇧ above, but includes *all* functions of a channel at the same time. This includes input gains, AUX, fader and bus assign. This function ‘clones’ the whole channel.

Hint for console setup: Set one channel to the desired status, including bus assignment etc., create a ‘super gang’ by linking all input channels together, and press ⇧ A (Copy/Paste All) twice. This will bring all linked channels into the same status.

↶ ↷ (Undo/Redo)

After having copied a setting into one channel, this key will reverse the last paste function. If a clear function has been performed, this key will reverse the last clear function. Note that ↶ ↷ (Undo/Redo) remembers each channel’s settings. It is therefore possible to undo a function on several channels by applying ↶ ↷ (Undo/Redo) on a gang.

There is also a shortcut for comparing settings within one channel:

- Press copy/paste in one channel twice (this copies the current value into the clipboard and pastes it back into the channel).
- Now change to an alternate value.
- When pressing ↶ ↷ Undo/Redo, the user can toggle between the two settings and compare by listening.

Note: By using the temporary function of this key, it is possible to compare the two settings with a single key press!

CLR

After having pressed this key once, all possible destination keys (audio on/off keys) are half-lit. Pressing one of them will reset its value to the default value. Selecting the ⇧ A (copy/paste all) key as the choice to clear will reset all parameters within this channel, including bus assignment. It is also possible to use the **MULTI SEL** key ([chapter 2.2.2.2](#)) to clear multiple functions. In order to set the fader of the channel to 0 dB, it is possible to touch the fader after having pressed **CLR**. After releasing the fader, it will set to 0 dB.

CLR can also be applied to a whole gang.

2.2.5 Control Bay Details

2.2.5.1 System/TB/Headphones



STBY Indicates that AC power is connected to the desk. Flashes, if redundant power supplies are fitted and power is lost on one of them.

MAIN ON Indicates that the power for the control system is ok. Pressing **ON** will switch the complete system (desk + control) on. For switching the system off, normally the Shutdown command in the windows desktop is used. Pressing **ON** for several seconds will activate an emergency shutdown.

DESK ON Indicates that the desk is switched on. For service purposes, it may be necessary to power off the desk part only, while the control PC remains on. This can be accomplished by pressing this key for several seconds. Another short press will power on the desk again. A warning message will be displayed and the GC will be re-started.

DATA USB port for plugging any USB compliant device for data backup of the console. It is possible to backup individual productions from within the Vista application software or to backup an image of the whole system. See [chapter 4.6.1](#) for more details about how to make image backups and how to restore them onto a console. The two USB ports at the rear of the console and the USB port are identical. So it can also be used to connect an USB keyboard in a 'quick and dirty' way.

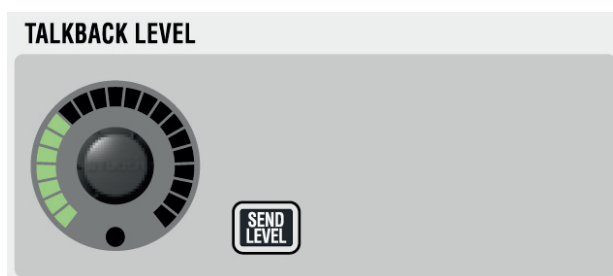

TALKBACK (Return) LEVEL Level setting for the talkback signal coming from the configured microphone input (usually, the presenter's microphone is used for talkback). The signal is fed into the near-field speakers.

SEND LEVEL If the **SEND LEVEL** key is active, the **TALKBACK LEVEL** knob adjusts the input sensitivity of the internal talkback microphone instead of the TB return level.



HEADPHONES

Adjusts the headphones level. The headphone signal is the same as the one listened to in the control room. However, whenever a PFL is active, the signal gets fed into the headphone with higher priority.

2.2.5.2 Assignable Meters and Meter Selection

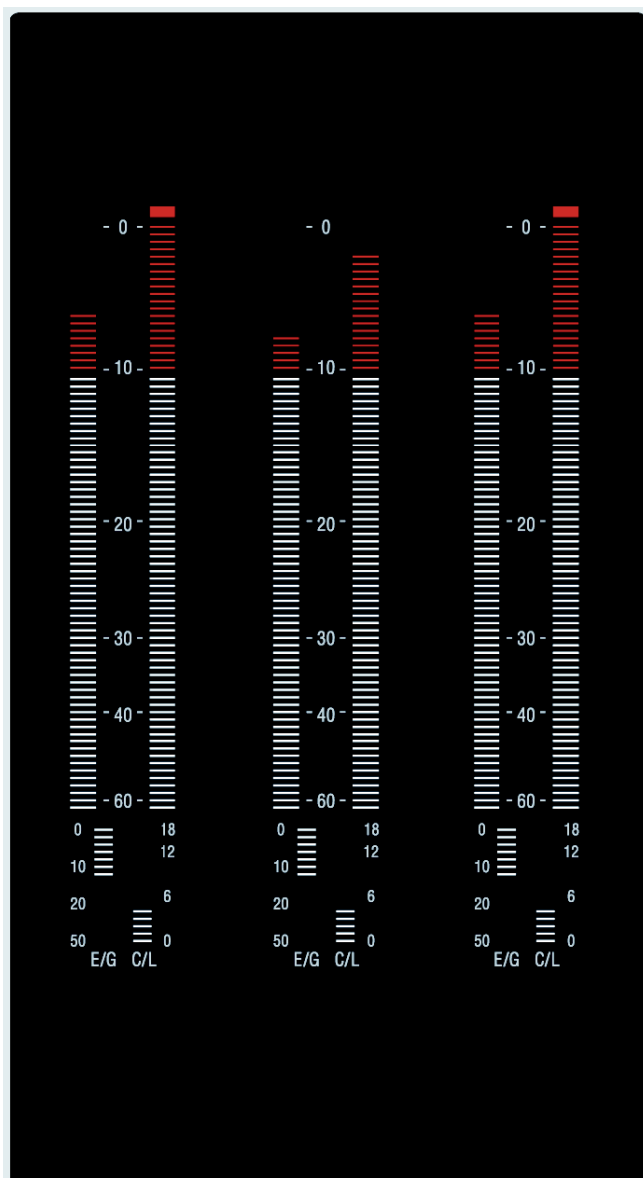

Assignable VFD Bargraph Level Meters

Indication of either monitor level (if **METER MON** in the **CONTROL ROOM** monitoring area is active) or the level of the direct outputs of the assigned channels.

Note: If a meter is assigned to a specific channel, it always displays this channel’s direct output level. If there is no patch set from that channel to an output interface, there will be no level visible on this meter.

The eight **METER** selector keys below the meters select from eight pre-assigned patch sets; the default assignment is shown left. These keys have snap-on caps for easy re-labeling if required.

For details about meter assignment refer to [chapter 4.7.3](#).

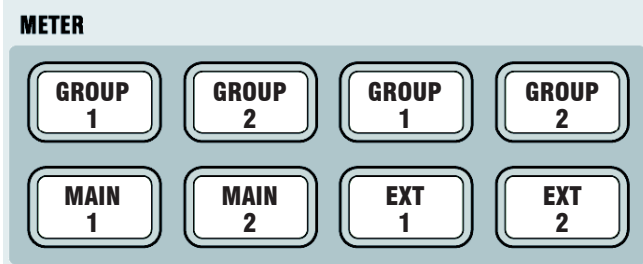

2.2.5.3 Control Room Monitoring



MONO, L-R, LCRS, 5.1 Selects the control room monitoring format. The monitoring section hosts a 5.1-to-two-channel downmixer. When **L-R** is active and the selected monitoring source delivers a 5.1 signal, the six channels get mixed down to two channels automatically. The way this downmix is done can be set in a dialog box on the Graphical Controller screen. This screen becomes visible by pressing the **SETUP** button.

The **MONO** setting will sum the left and right monitor speaker signals.

⊕ **Ø**, ⊕ **X** Phase inversion on left channel, and left/right channel swap for mono or two-channel stereo mode.

⊕ **INS DEC** Inserts the encoder/decoder chain into the monitoring path. Inputs/Outputs can be found on the rear of the desk. This function needs to be activated in a .ini file on the system at installation time. *Edits may only be done by educated Studer service personnel.*

⊕ **METER MON** Makes the monitor meters indicate the monitor output signal levels instead of the pre-assigned signals.

⊕ **L**, ⊕ **C**, ⊕ **R**, ⊕ **LS**, ⊕ **RS**, ⊕ **LFE** These keys act as solo or mute keys for each speaker being currently active, depending on the monitoring format selection. Mode is pre-selected by the **SOLO** and **MUTE** keys located above these keys. It is also possible to clear all pressed keys at once with the circular **CLR** key next to **MUTE**.

SOLO, SOLO IN PLACE These keys define the mode the console is in when a channel strip **SOLO** key is pressed. It can be either **SOLO** (post-fader listening incl. pan), or **SOLO IN PLACE** (solo by muting all channels but the selected one, masters and other defined channels; destructive mode). Pressing **SOLO** for several seconds allows adjusting the solo offset level applied in the monitoring whenever a solo is active. The offset level is then indicated by the 'dB SPL' display that



normally shows the control room listening level. Turn the knob below the display for adjustment of solo offset level.

CLR If any of the **PFL** or **SOLO** keys on the console is active (even if it is currently not visible on the surface), this key will be lit. Pressing it clears all activated **PFL/SOLO** functions on the channels.

EXT PFL SPEAKER This rotary control adjusts the level of the PFL signal going to the near-field speakers. The near-field speakers are also used for listening to talkback return signals.

PFL TRIM Pressing this key allows adjusting the solo offset level applied in the monitoring, whenever PFL is active. The offset level is displayed in place of the control room level. Turn the **dB SPL** control room level knob for solo offset level adjustment.

LIVE If active: Disables some functions potentially dangerous during live work, such as ‘talkback to masters’ or ‘solo in place’. It is also possible to use this key to arm the cue list, so that the **NEXT** and **PREV** desk keys are activated. See static automation settings in [chapters 4.4.4 and 4.4.4.5](#).

PFL BC Activates a mode where PFL or SOLO on a channel is automatically canceled whenever the channel fader is open. A setting in the ‘Vista Desk Settings’ menu allows activating the function where the PFL/SOLO comes back after the fader has been closed again.

CR INJECT If active: PFL signals will be audible in the main control room speakers as soon as any **PFL** function is activated. Channels with **SOLO** active are always inserted into the control room.

SIP SAFE Pressing this key enters setup mode for editing the channels that should be safe from muting when activating **SOLO IN PLACE** on any other channel; by default, all master channels are safe from muting when **SOLO IN PLACE** is active. It may be desirable to protect effect returns from muting by adding them to the group of safe channels. When in **SIP SAFE** setup mode, it is possible to select or de-select individual channels on the desk by pressing their **LINK / SEL** key. Pressing **SIP SAFE** again will cancel edit mode and activate the selected SIP protection. The information on the channels to be protected is saved in each title, and therefore may vary from title to title.

Note: As a standard, the **MULTISEL** function is active when entering **SIP SAFE** setup mode. In this way it is possible to select or de-select any channels to be safe from muting. However, for clearing *all* currently selected and safe channels (including master channels), **MULTISEL** may be de-activated. When pressing any **LINK / SEL** key of a channel, all others will be de-selected in one go.

⊕ **NEAR FIELD**, ⊕ **MAIN** Selection of two speaker sets: **MAIN** is multi-channel surround (5.1), **NEAR FIELD** is a two-channel stereo system. A separate level control is available for each set of speakers, but can be deactivated at installation time. This usually is done by the system administrator in the monitoring.ini file.

The near-field speakers, in addition, are used as PFL speakers and for monitoring an off-air conference between external participants. The priority of what signal is audible is defined as follows:

1. PFL (unless **CR INJECT** active)

2. Near-field speakers

3. Off-air conference.

The level may be set differently for each of these cases. EXT PFL level may adjust the off-air conference monitor level as soon as this signal is monitored.

⊕ **MUTE**, ⊕ **DIM**, dB SPL Display For muting, dimming, and setting the level of the control room speakers. **DIM** level may be adjusted by pressing this button several seconds. The corresponding **DIM** level is displayed in the control room level display. Adjust the **DIM** level with the control room level (**dB SPL**) knob.

Note: The level calibration of the different speakers as well as trimming the individual speakers is done using the Graphical Controller screen, refer to [chapter 4.6.2.1.1](#).

2.2.5.4 Studio Monitoring

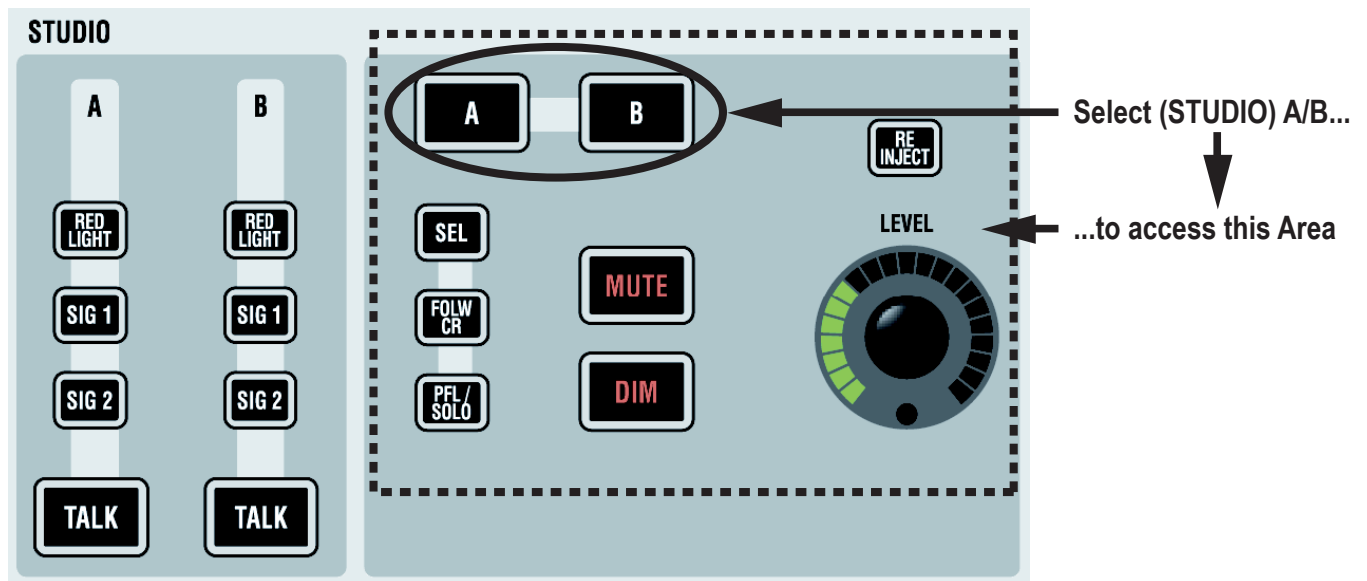

A / B RED LIGHT, SIG 1 (Ready), SIG 2 (Call), TALK

These functions can directly be activated for two different studios. The keys may light automatically if the function has been activated by using GPI (general purpose inputs).

A, B, SEL etc. The right part of the studio monitoring panel is used to control the audio level of the two studios. First select the studio (**A** or **B**), then adjust the level and select from 'Selected Source on Source Selectors' (**SEL**), feed studio with same source as control room (**FOLW CR**), or send PFL/SOLO signals to the studio (**PFL/SOLO**). It is also possible to disengage the mute mechanism normally activated by the red-light logic. This is done by activating **RE-INJECT**.

⌚ **MUTE**, ⌚ **DIM** For muting or dimming the level of the studio speakers. **DIM** level may be adjusted by pressing this button several seconds. The corresponding **DIM** level is displayed with the LED ring around the **LEVEL** control.

2.2.5.5 Monitoring Source Selection

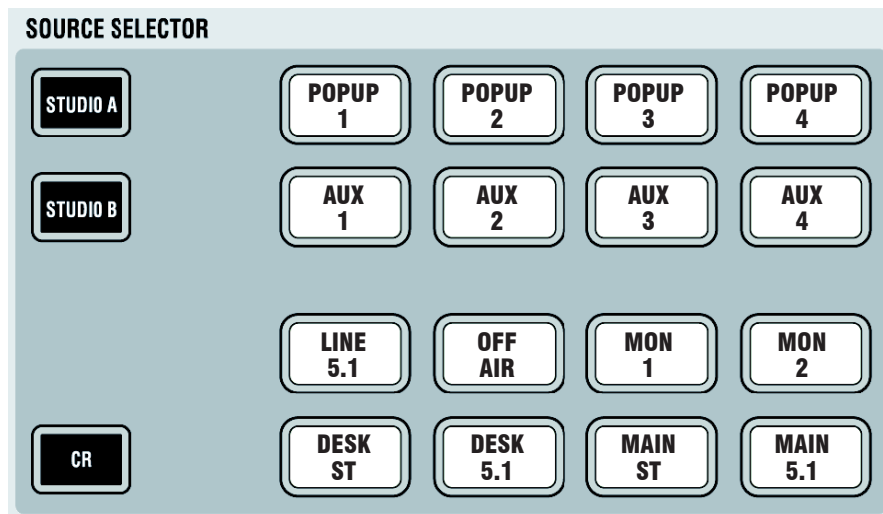

First select the target to be changed: **CR** (control room), **STUDIO A**, or **STUDIO B**. Then select the appropriate source key. All keys are fully user-definable by using the monitoring setup dialog in the Graphical Controller application (accessible to system administrators only). Each key may independently feed a set of one to six loudspeakers. It is therefore possible to have a two-channel stereo source on one key, while another key selects a 5.1 surround source.

The 16 keys have clip-on caps for inserting individual labels mirroring the configuration. Shown above is the factory default definition.

Note: For the control room, it is possible to activate the **SOURCE SELECTOR** top row to be ‘sub-selectors’ rather than selectors, allowing 12 sources to be assigned to each of these keys. This functionality makes 60 sources available for listening in the control room, rather than the standard 16. Activation is done by editing the monitoring.ini file. *This usually is done by the system administrator only.*

Pressing one of the ‘sub-selectors’ will make one of the 12 sub-sources selected and audible in the monitoring. Pressing the sub-selector again will open up a list of all 12 sources available for this sub-selector on the Graphical Controller screen. Select any of the 12 with the touchpad, then close the dialog by pressing the same sub-selector key again. If none of the 12 sources is selected, the dialog will pop up automatically upon the first key press in order to make a selection with the touchpad.

2.2.5.6 Custom Panel (GPIO Keys)

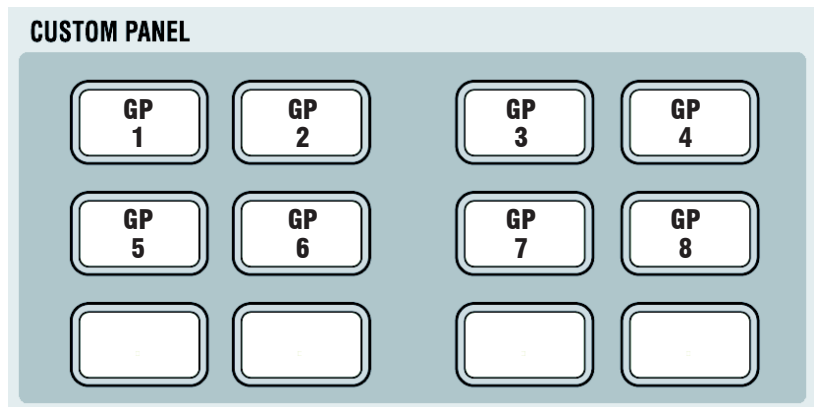

This area contains keys for controlling the general purpose control outputs (GPO). The control inputs (GPI) can be used for illuminating the keys. The factory default configuration is GPO 1-12 on the **CUSTOM PANEL GPIO** socket on the rear panel, for the pinout refer to [chapter 2.1.4.1.1](#).

Keys no. 7-12 may also be reconfigured to control desk-internal tasks, such as cue list functions.

2.2.5.7 Jingle Player

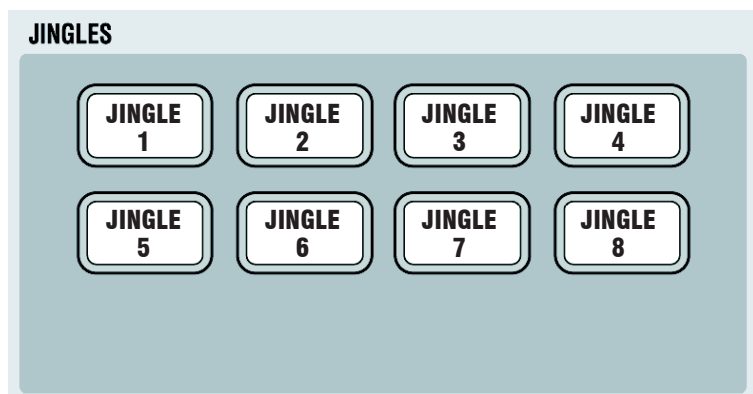

The integrated jingle player is a stereo playback-only device intended for up to eight different audio clips, such as station identifier jingles, applause etc., that can be triggered from the eight **JINGLES** keys shown above.

A jingle immediately starts playing upon pressing one of these keys. While the clip is playing the key is illuminated. If the key is pressed again while playing, the clip immediately restarts. If a different jingle key is pressed while a jingle is playing, playback stops, and the new clip immediately starts.

These clip files come from a USB memory device (e.g. USB stick) that is connected to the USB socket located below the handrest next to the headphones socket.

The jingle player keys have clip-on caps that allow inserting individual labels, mirroring either the audio file names or the jingle key numbers.

The Virtual Vista application shows the jingle player buttons in 'Online' mode only.

For additional Jingle Player information and requirements please refer to [chapter 2.2.9](#).

2.2.5.8 Talkback Control

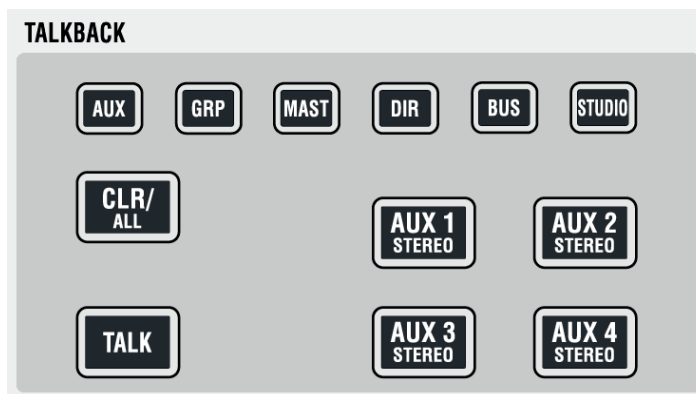

⊕ **TALKBACK** Whenever **TALK** is pressed, the signal from the talkback microphone input is fed to the corresponding group.

The talkback input usually is microphone input no. 32. It is pre-configured but not activated, refer to [chapter 2.1.5](#).

Note: The talkback signal is inserted directly before the output interface of the core. If signals are routed internally to some other destinations, the talkback will not harm them.

Available talk destinations:

AUX Direct outputs of all AUX masters

GRP Direct outputs of all group masters

MAST Direct outputs of all masters

DIR Direct outputs of all input channels

BUS Outputs of all multi-track buses (without faders in between)

STUDIO Talkback to both Studio A and B simultaneously).

⊕ **AUX 1...4 STEREO** For talking to headphone mixes, these keys can be used to directly activate talkback to the corresponding AUX master outputs.

A talkback and signaling block diagram is shown on the next page.

Talkback and Signaling Block Diagram **VISTA 1** DIGITAL MIXING CONSOLE Using Desk-Internal GPIO

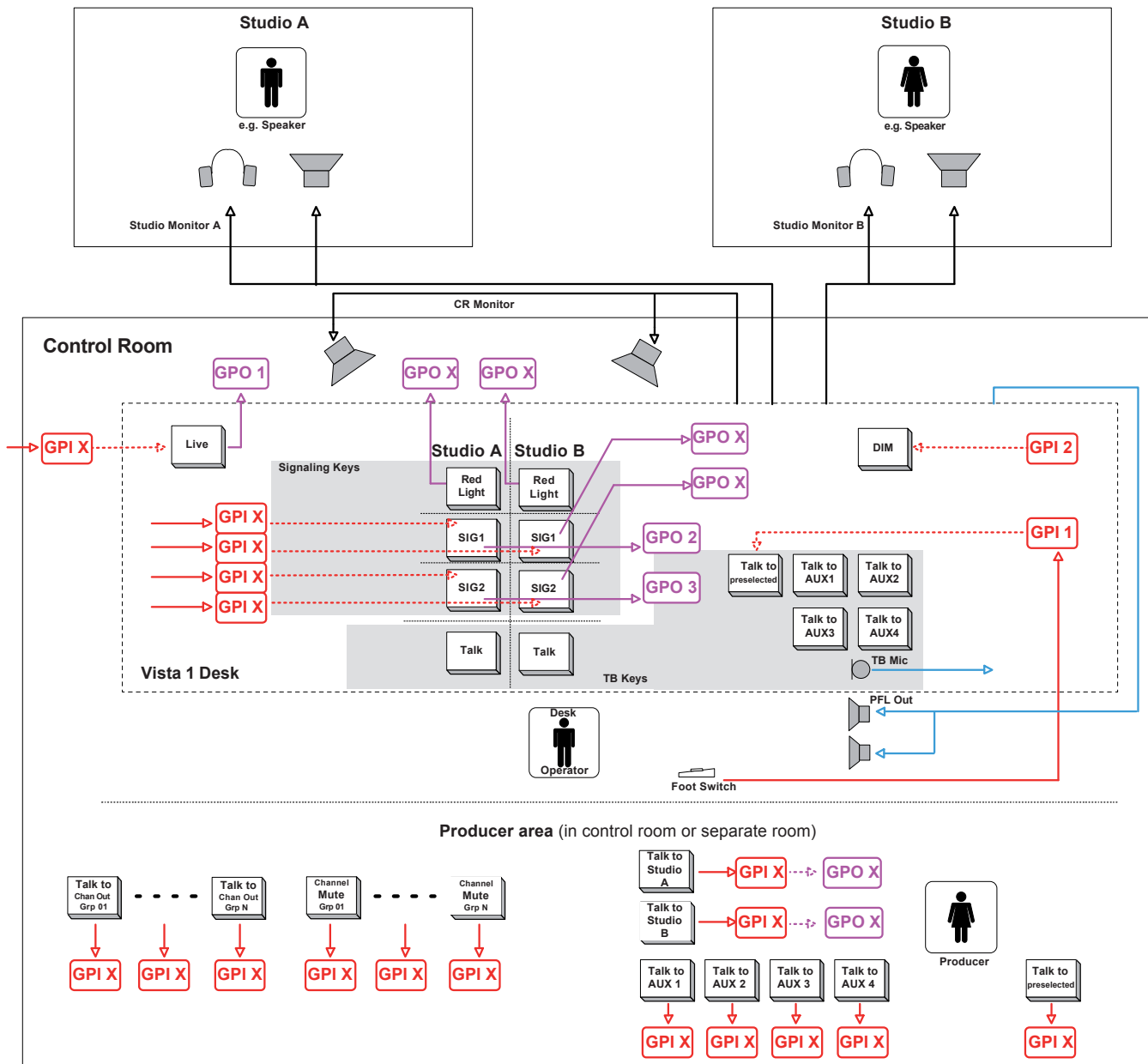

Legend:

- GPI 1 = GPI already configured in .ini files
- GPI X = GPI prepared to use, but not assigned to signaling card. Can be configured in .ini files
- GPO 2 = GPO already configured in .ini files
- GPO X = GPO prepared to use, but not assigned to signaling card. Can be configured in .ini files

Already configured:

- GPI 1 Footswitch to talk to preselected
- GPI 2 CR DIM
- GPO 1 Live Key on Desk
- GPO 2 Signaling 1 Studio A
- GPO 3 Signaling 2 Studio A

2.2.5.9 Control and Mute Group Setup

2.2.5.9.1 Control Group Setup

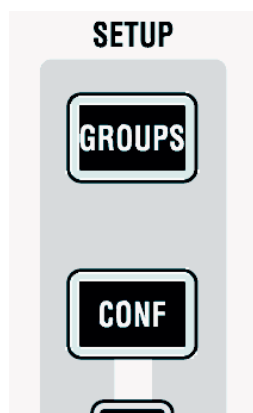

SETUP: GROUPS

Pressing this key will enter/exit control group *and* mute group mode.

After having entered **SETUP: GROUPS**, the user selects the control group he wants to edit by pressing **LINK / SEL** on the corresponding control group master channel. Then the desired channels are added to or removed from the control group by pressing their **LINK / SEL** key. The 7-segment display next to the channel fader indicates the control group number.

The control group assignment is saved within each snapshot, therefore the assignment may change from snapshot to snapshot.

*The **MULTISEL** key is active as standard, thus allowing to select and de-select individual channels. Clearing the entire definition of a control group is easily done by pressing the **MULTI SEL** key, so that it gets dark. After that, any press on **LINK / SEL** of any channel will clear all others. It is also possible to add multiple channels to a control group: Press and hold one **LINK / SEL** key and press another one on a different channel. All channels in between will be added to the control group.*

2.2.5.9.2 Mute Groups

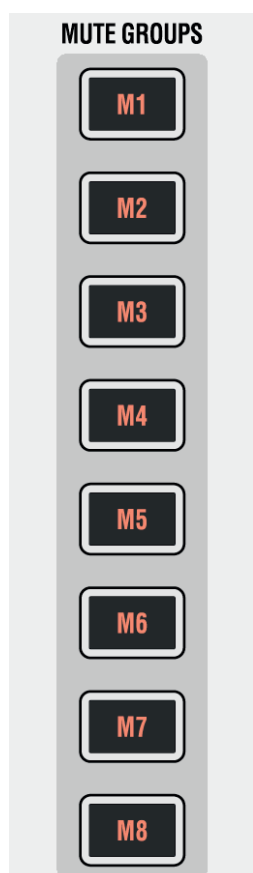

SETUP: GROUPS

Pressing this key will enter/exit control group *and* mute group mode.

Vista 1 provides up to 16 mute groups. **MUTE GROUPS M1...M8** have dedicated keys on the left side of the control bay.

The additional mute groups M9...M16 may be operated using eight of the 16 monitoring source selectors.

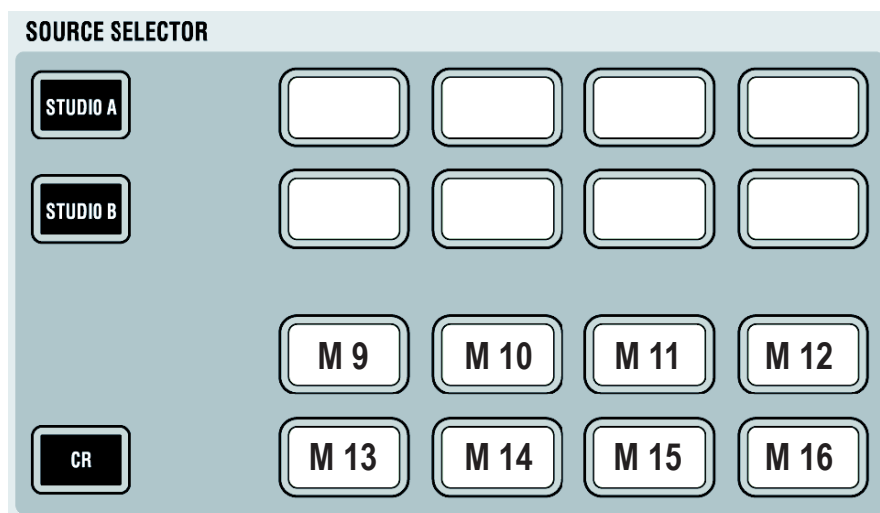

Use of these keys (either as monitoring source or as mute group selectors) is defined in the 'Option: Vista Settings' menu, as shown below.

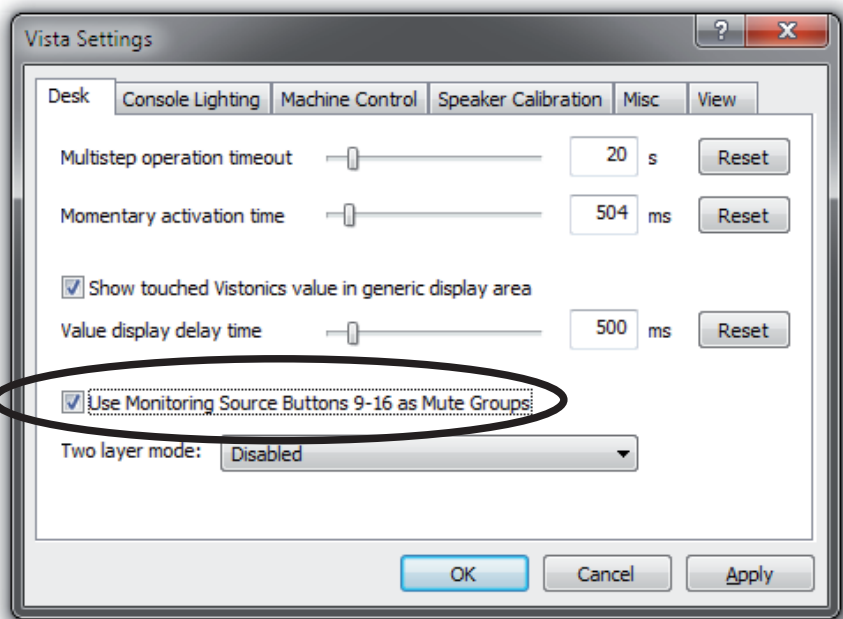

2.2.5.9.3 Setting up a Mute Group

Press the **SETUP: GROUPS** key on the control bay. The mute group master keys (dedicated **MUTE GROUPS M1...M8** keys, and, if defined, keys **M9...M16** in the **SOURCE SELECTOR** area, see above) will be half-lit.

Select the mute group you want to setup. A dialog will pop up on the Graphical Controller screen, allowing you either to add all currently muted channels on the console to this mute group with one touchpad click, or to clear all members from the selected mute group. You may also select or deselect members using their **LINK / SEL** key. Press the mute group master key again in order to select another one. Please note that hierarchies can be built up as well. In other words, a mute group may contain individual channels as well as another mute group master. Hierarchies are not indicated on the desk once the set-up menu is quit. The area below the channel labels indicates whether a channel is a member of one or multiple mute groups.

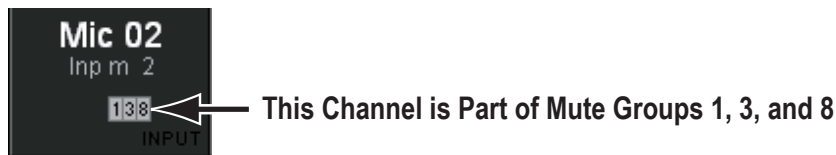

Press **SETUP GROUPS** again in order to leave the setup mode. *Assignment of channels to mute groups are saved within a so-called 'start snapshot' of each title. I.e., this information is saved once per title when the title is closed.*

2.2.5.9.4 Off-Air Conference

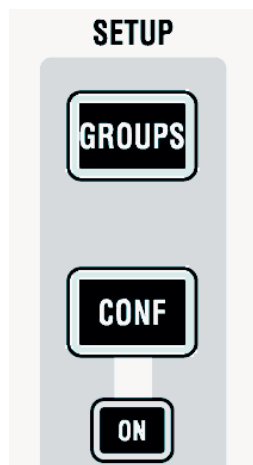
**SETUP: CONF**

If the DSP configuration contains n-x buses, it is possible to setup an off-air conference between n-x owner channels. After pressing this key, all n-x owner channels become half-lit and members of a conference can be selected (full-lit). As soon as their fader is closed, they will be able to talk to each other. The conference setup is immediately edited, also while the console is still in the setup mode. This allows for frequent changes of the conference members, e.g. during election reports. Talking to a member of the conference will activate talkback to the whole conference at the same time.

SETUP: CONF ON

The **ON** key is lit as soon as a conference is set up. The conferencing may temporarily be deactivated by clicking on the conference icon  in the toolbar or by pressing **CONF ON** on the control bay. In this case the conference definition is retained. As soon as the conference is reactivated globally (by pressing **CONF ON** or clicking on the conference icon in the toolbar again), the previously selected channels may talk to each other again.

The conference icon in the toolbar has two states:

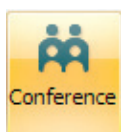

Conference not deactivated

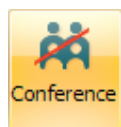

Conference temporarily deactivated (even if member faders closed).

Note: In certain circumstances, also an AUX master can be selected as a conference member (indicated by its half-lit **LINK / SEL** key). This is intended for adding e.g. an on-air signal to the conference. For more information refer to [chapter 4.6.1.1.3](#).

2.2.5.10 GC Shortcut Keys

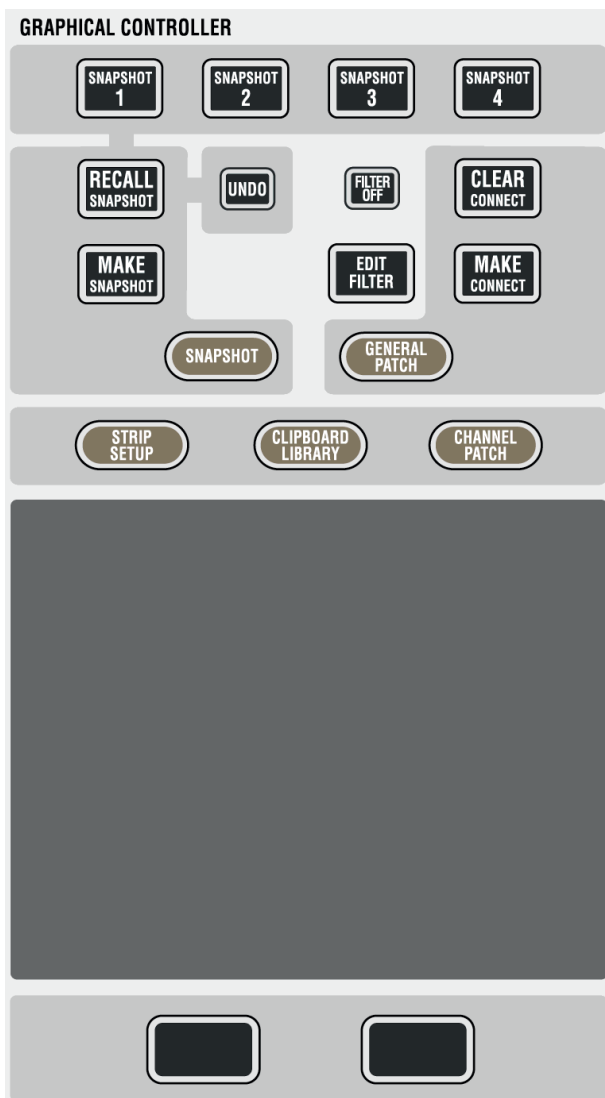

SNAPSHOT 1...4

A snapshot contains all audio settings including patching and labels.

These keys allow four snapshots to be saved and recalled without making use of the Graphical Controller screen.

- *Making a snapshot:*
Press and hold **MAKE SNAPSHOT**, then press one of the **SNAPSHOT 1...4** keys. This will program this key with the current audio settings.
- *Recalling a snapshot* that has been programmed on one of the **SNAPSHOT 1...4** keys:
Press and hold **RECALL SNAPSHOT** while pressing one of the **SNAPSHOT 1...4** keys. This will recall the snapshot instantly, if warning mode is not active (see description of the 'Options' menu on the Graphical Controller.)
- *Preview of a snapshot* that has been programmed on one of the **SNAPSHOT 1...4** keys:
Pressing one of the four keys will activate a preview of that specific snapshot and illuminate it. Values in the previewed snapshot that are different from the current console settings will be visible on the Vistonics modules using *magenta-colored* indicators. ☺ This preview function can also be activated momentarily or latching.

MAKE / RECALL SNAPSHOT

Pressing and releasing **MAKE SNAPSHOT** will create a snapshot with an automatically generated name, listed in the Graphical Controller. Filtering may be applied upon recall of the snapshot, refer to [chapter 4.4.4.5](#).

MAKE / CLEAR CONNECT

If the general patch window is opened on the Graphical Controller, these keys will make or clear a patch connection at the intersection of the red lines.

FILTER OFF

This key switches all currently active snapshot filters temporarily off. After de-activation the filter settings are back and they need not be re-defined.

EDIT FILTER, STRIP SETUP, SNAPSHOT, CLIPBOARD LIBRARY, GENERAL PATCH, CHANNEL PATCH

These shortcut keys will open the corresponding windows on the Graphical Controller.

2.2.5.11 Cue List Keys



These keys give direct access to the cue list on the control bay. They can be used to control various functions of the cue list and allow certain functions to be switched using a hardware key, while it remains possible to use the touchpad and operate these functions on the Graphical Controller screen:

- Switching on/off the cross-fade function between cues
- Activate or inactivate the cue preview mode
- Go to the next or previous cue.

Note: To prevent accidental use, the **PREV** and **NEXT** keys are only active if ‘Arm Cuelist’ is switched on in the Graphical Controller screen. The corresponding keys PREV and NEXT on the screen, however, are always active.

7	Listen to your daddy		2.0	MUTE	🎭
8	Cant anybody make Crown stop		2.0	MUTE	
9	You done bring trouble enough		2.0	MUTE	🎭
10	Where is brudder Robins	Act1Sc2	2.0	MUTE	🎭
11	Come on Sister		2.0	MUTE	🎭
12	Gown got plenty		2.0	MUTE	
13	Overflow		2.0	MUTE	
14	My mans gone		2.0	MUTE	🎭
15	How de saucer stan now		2.0	MUTE	🎭

2.2.5.12 Joystick



Display

Indicates the label of the channel currently assigned to the Joystick.

⇅ Y axis lock

⇔ X axis lock

Lock the Y axis (⇅) or X axis (⇔) when moving the joystick. Pressing ⇅ and ⇔ simultaneously deactivates the joystick completely and clears the assignment to a channel.

FOLLOW

Activates the joystick to display the currently selected channel (select with **LINK/SEL**). If a gang is present, the joystick will influence the whole gang. **FOLLOW** can be deactivated by a second press; the joystick will then stay assigned to the current channel.

DEFINE FOLW

When a gang is active and the joystick is set to **FOLLOW** mode, the joystick will physically move to the average of all the pan values of the gang, allowing the user to make slight adjustments very quickly. However, if the user wants to do a 'full' pan, so that all channels will be e.g. fully left, he needs to define the channel for the joystick to display. The joystick will then move to the pan position of the defined channel, but will still keep influencing the whole gang.

Example: One dialog microphone is moving together with the ambience channels. The gang will include all channels even if the joystick is defined to show the dialog microphone by using **DEFINE FOLW**.

Operation: Create a gang, have **FOLLOW** on. Press **DEFINE FOLW** and select one of the gang members (use the half-lit **LINK / SEL** keys as guides).

2.2.5.13 Fader Page Navigator

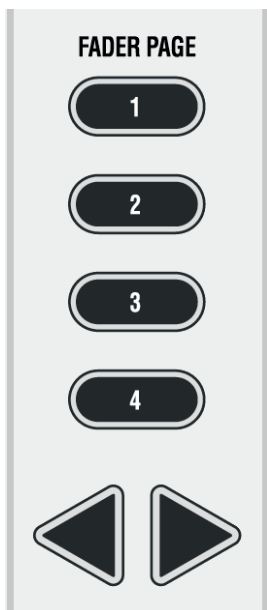

These keys allow changing the Control Bay faders to different pages. Each page may be scrolled by 10 faders to the left or right, allowing for a total of 120 channels to be displayed in the control bay. Any channel type may be placed on the Control Bay channel strips, including masters and input channels. Which channels are displayed on which page can be configured with the Graphical Controller, in the top right corner of the strip setup window under the Control Bay tab.



2.2.5.14 Grand Master Faders

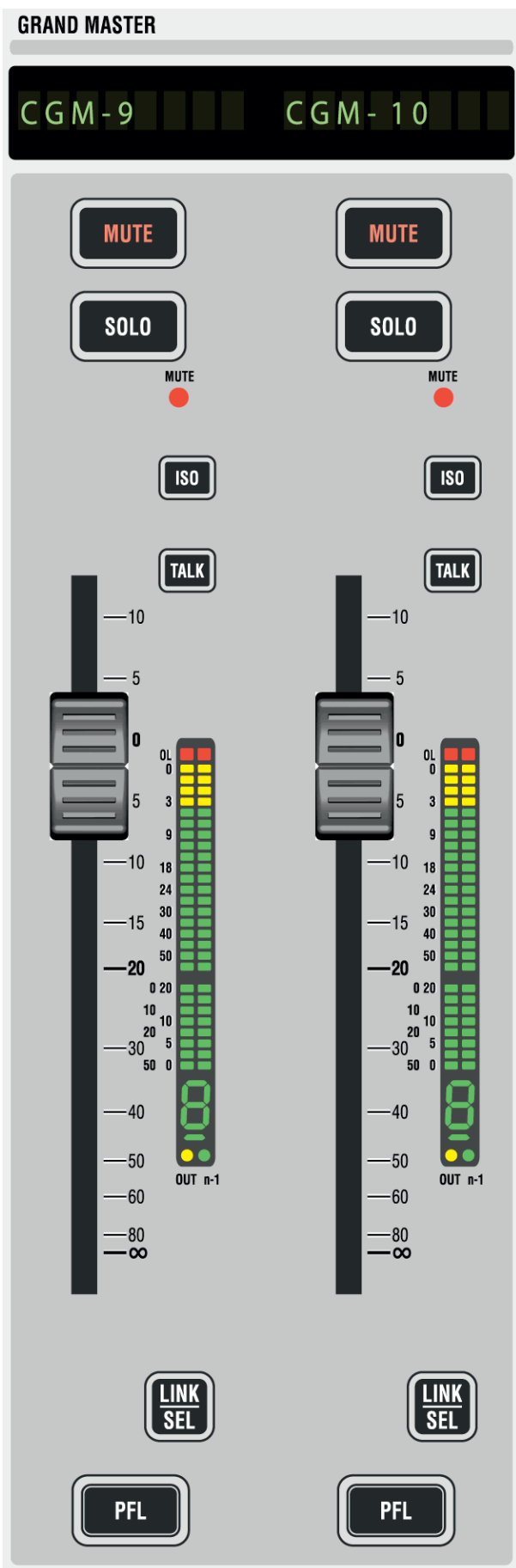

Vista 1’s control bay also hosts two ‘grand master’ faders. The user determines which two faders are the most important ones for him and to which he wants to have constant access. This may be very useful as an ‘emergency access’ to very important output faders, since these faders will never scroll or be switched over in any way. Which two channels are controlled by these faders is defined with the Graphical Controller, in the top right corner of the strip setup window under the Control Bay tab, as shown above.

Note: Any two console faders can be assigned as ‘grand master’ faders, regardless of their channel type.

2.2.5.15 Stereo Channel Fader Unfold on Grand Masters

From SW V5.3 onwards, an exceptional use is made of the Grand Master faders. The Grand Master faders can optionally be used to display and adjust L and R fader values from any stereo channel.

This functionality that can be used on any stereo channel (input, group, aux, master) is described as follows :

In addition to the settable input gain of each stereo channel leg, also a fader value offset can be set individually for the L and R channel leg.

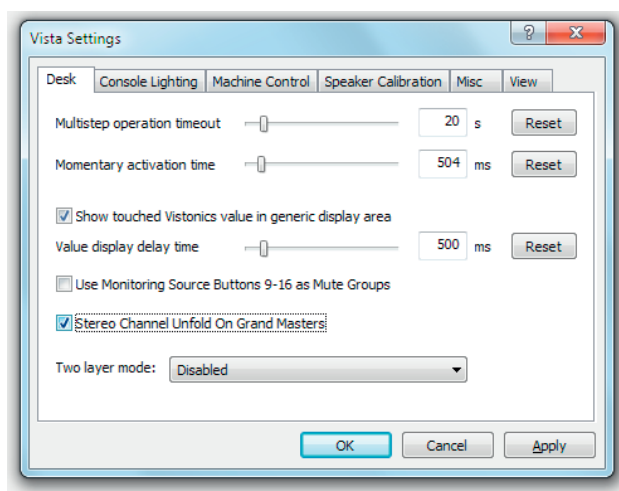

With the Vista Setting “Stereo Channel Fader on Grand Masters” the operator can press the **CHANNEL VIEW** key to unfold the stereo channel onto the Grand Master strips of the ControlBay. The **CHANNEL VIEW** key then is flashing and the two Grand Master faders are temporarily representing the separate L and R offset fader values of that stereo channel. Now the L and R offset values can be adjusted.

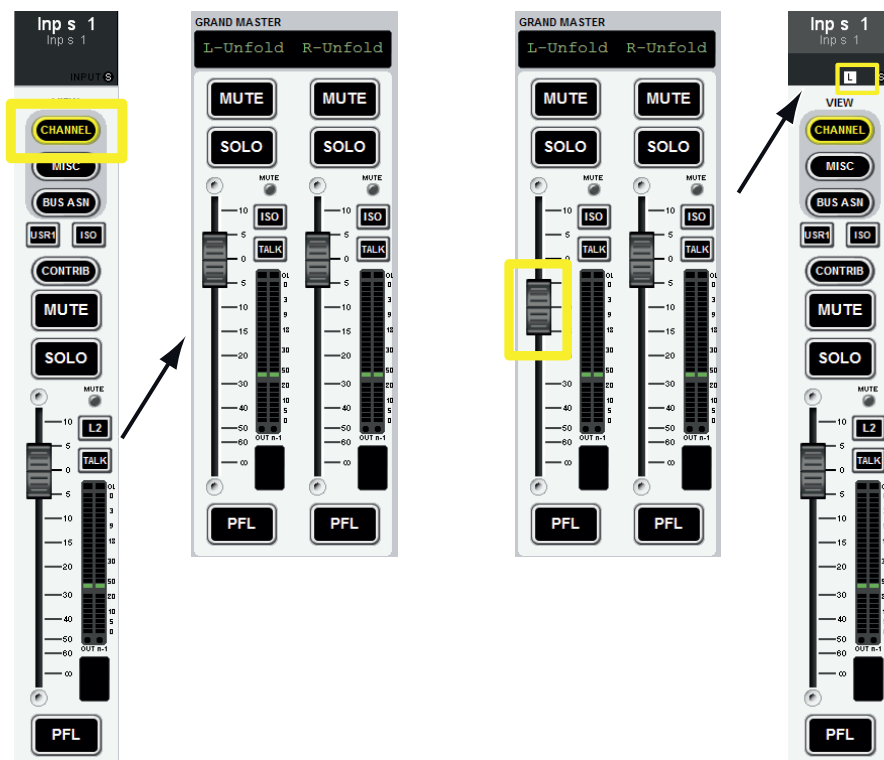

As soon as the separate offset fader values differ from the main fader value, this offset is indicated with a small “L” or “R” icon in the label area.

During this temporary action, the channels that are assigned to the Grand Master Strips in the Strip setup, are currently not shown and cannot be operated for as long as the **CHANNEL VIEW** of a stereo channel is active. Since this is major exception to the Vista operation concept – the **CHANNEL VIEW** key is flashing during this time.

The fader of the channel strip still controls the main fader level of the stereo channel while the two offset fader values remain static.

Note : The resulting fader level is :

Fader L = Fader Main + Fader Offset L
Fader R = Fader Main + Fader Offset R

Only stereo channels of VMC configs that are (re-) calculated with the V5.3 CoreCfgTool provide this feature. The process to recalculate existing configs is as follows :

1. Open the existing .VMC file with the CoreCfgTool V5.3
2. Go to the channel/bus view and select the desired stereo channels
3. Double-click on the newly provided Library function “Split Fader Stereo”
4. Save the config with a new name and click “Generate All”
5. Load this config and create a new title or convert an existing title to the new config.

2.2.5.16 Output Views / FOLLOW

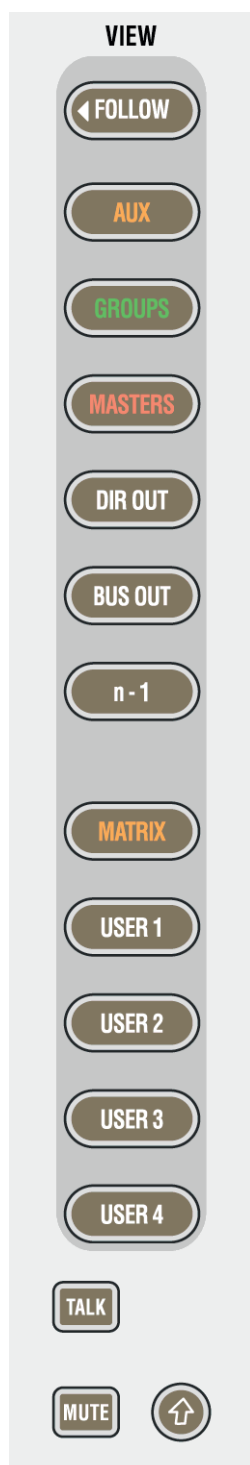

Besides the monitoring and housekeeping functions the control bay hosts twelve faders and a Vistonics screen. The faders are independent from the rest of the console in terms of changing fader pages.

Unless the **FOLLOW** view is active, the Vistonics screen is used as a collection of 40 level controls, usually representing a duplicate view of the fader bays' channel faders. The Vistonics controls will then not only give access to the channel faders and graphically indicate their settings, but is also indicate a real-time level meter on the screen right next to the corresponding rotary control. This allows viewing up to 40 meters at a glance while having direct access to all of their corresponding faders by using the rotary control next to it. Tweaking any of the console's output levels is therefore extremely easy and fast.



The **VIEW** keys on the right-hand side of the control bay allow access to some predefined channel types (**AUX**, **GROUPS**, **MASTERS**, **DIRECT OUT**, **BUS OUT**, **n-1**) as well as to five user-definable views. By using the third page (**Vistonics Views** tab) of the strip setup window (next page), it is possible to define the user setups in a way very similar to the strip setup. In order to make a user view, simply select the Vistonics elements on the screen and fill them up using the right touchpad button (as shown in [chapter 4.4.6.1](#)). Although primarily intended for outputs, also input faders can be visible and controlled with these **USER** views.

The top user-definable view is labeled **MATRIX**. This page is also fully user-definable and covers the same functionality as the other four **USER1-4** keys. As a standard the user may want to use the **MATRIX** key to see the console's matrix outputs.

The function of the Vistonics keys next to each rotary knob on the Vistonics screen may be modified by pressing the **TALK** or **MUTE** keys, changing the Vistonics key from a SOLO/PFL/SIP key (depending on the current mode) to a **TALK** or **MUTE** key.

- Note:** These functions may not be available on certain channel types.
- Apart from displaying meters and set levels, the Vistonics screen also indicates the label of the displayed channel with the color coding applied accordingly.
- ⊕ Temporary activation of these keys is possible.
 - ⬆ The ⬆ (shift) key is reserved for future use and has no function currently.

C:\D950PROJECTS\Musical\Porgy and Bess\StandardStripSetup

MATRIX	Matrix m 9	Matrix m 10	Matrix m 11	Matrix m 12	Matrix m 13	Matrix m 14	Matrix m 15	Matrix m 16
USER 1	Mst m 1	Mst m 2	Mst m 3	Mst m 4	Mst m 5	Mst m 6	Aux m 1	Aux m 2
	Aux m 5	Aux m 6	Aux m 7	Aux m 8	Matrix m 9	Matrix m 10	Matrix m 11	Matrix m 12
	Grp m 1	Grp m 2	Grp m 3	Grp m 4	Grp m 5	Grp m 6		
USER 2	Aux m 1	Aux m 2	Aux m 3	Aux m 4	Aux m 5	Aux m 6	Aux m 7	Aux m 8
	Matrix m 11	Matrix m 12	Matrix m 13	Matrix m 14	Matrix m 15	Matrix m 16	Aux m 17	Aux s 1
	Grp m 1	Grp m 2	Mst s 1	Mst s 2	Grp m 3	Grp m 4	Reverb m 1	
	Control Master 1	Control Master 2	Control Master 3	Control Master 4	Control Master 5	Control Master 6		
USER 3	Gen Generator 1	Gen Generator 1	Gen Generator 1	Gen Generator 1				
	Matrix m 9	Matrix m 10	Matrix m 11	Matrix m 12	Matrix m 13	Matrix m 14	Matrix m 15	Matrix m 16
	Mst m 1	Mst m 2	Mst m 3	Mst m 4	Mst m 5	Mst m 6		
	Grp m 1	Grp m 2	Grp m 3	Grp m 4	Grp m 5	Grp m 6	Grp s 1	Grp s 2

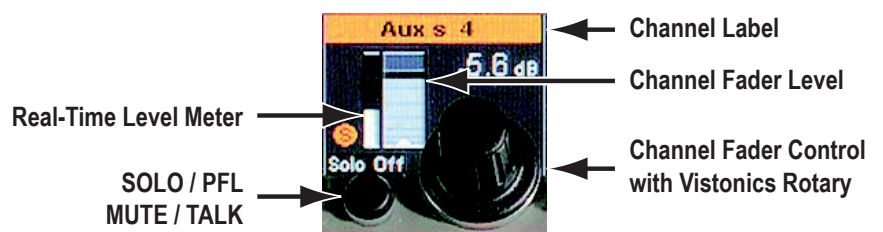

FOLLOW If this key is active, the view on the control bay Viconics will follow the **GLOBAL VIEW** of the fader bay, indicating the same 4 parameters per channel strip belonging to each of the 10 faders below. This mode makes the control bay become a fully functional fader bay, and it may be used to operate input channels.

2.2.5.17 Contribution Access



Very often it is useful to operate the console in ‘reverse’ way, coming from an *output* fader and operate the various *input* channels contributing to this output. By pressing one of the **CONTRIB** keys located above the faders the Vistonics rotaries will show all channel faders currently contributing to this master signal. In case of a matrix or AUX master output, the view shows all channels contributing to this output, hence input, subgroup or master channels.

‘Contribution’ can be operated in two ways, depending on the state of the **REDUCED (View) ON** key on the left-hand side:

REDUCED (View) ON When pressing **CONTRIB** only the channels currently assigned to the corresponding master bus are displayed.



REDUCED (View) OFF All channels that *may* contribute are displayed. These are all channels that can be assigned to that specific output bus. This view allows assigning or de-assigning them from the master bus by using the corresponding Vistonics keys.

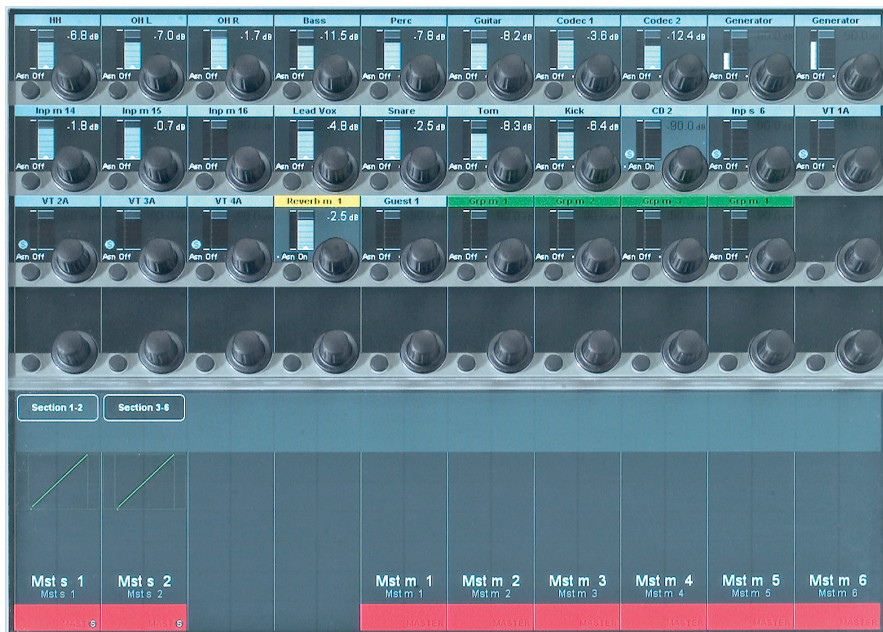

This way, it is easy to adjust a balance of e.g. a matrix output without having to access the fader strips of the contributing channels.

When working in **REDUCED (View) OFF** mode, another advantage becomes apparent: The operator may now set up busses by first selecting the output and then assign the corresponding channels to it.

2.2.5.18 SpillZone

In addition to the ‘Contribution’-function, it is also possible to make use of a SpillZone. The SpillZone is a defined FaderBay (or several bays) where contributing channels are temporarily shown instead of the assigned channels as defined in the StriSetup.

By using the SpillZone it is not only possible to balance levels of contributing channels, but to have access to all channel parameters. This can be very helpful when operating large channel numbers.

Setting up the SpillZone The SpillZone can be defined in the StripSetup under the Tab Spill Zone

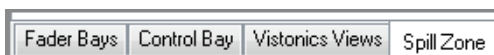

When selecting the Tab Spill Zone, the desks FaderBay channel strips are shown. Clicking into one of the FaderBay-areas creates a large arrow. This arrow defines the position of the number of channel strips (always in blocks of 10 strips) that are used for the SpillZone. The direction in which the arrow points is the direction in which channels are filled up into the SpillZone. Clicking into the FaderBay-area and moving into either direction while click-

ing, defines the direction of the arrow.

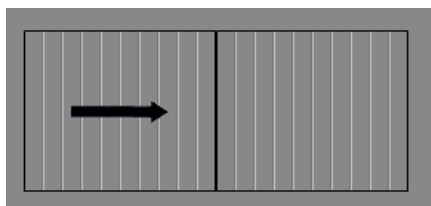

The spilled channels will be lined up starting from the leftmost channel strip across one FaderBay.

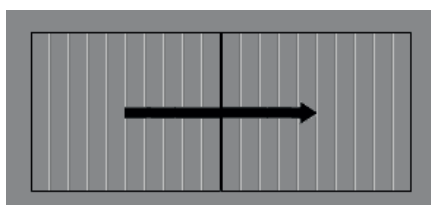

The spilled channels will be lined up starting from the leftmost channel strip across two FaderBays. (all FaderBays on this 32 fader desk).

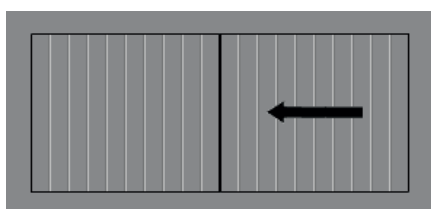

The spilled channels will be lined up starting from the rightmost channel strip across one FaderBay.

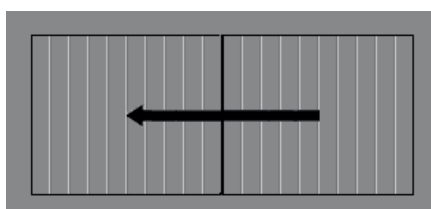

The spilled channels will be lined up starting from the rightmost channel strip across two FaderBays. (all FaderBays on this 32 fader desk).

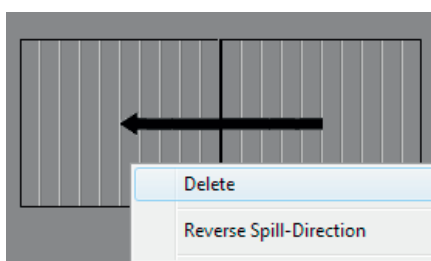

By right-clicking onto the SpillZone setup area, a menu appears which lets the operator either delete the SpillZone or reverse its direction. By deleting the SpillZone, the SpillZone functionality is switched off and normal contribution is shown when pressing any **CONTRIB** key.

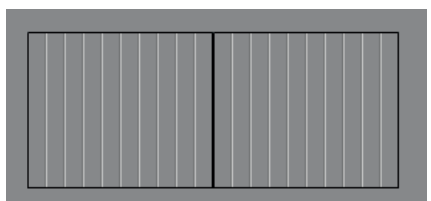

This shows the SpillZone setup page with deactivated SpillZone functionality.

The setup of the SpillZone is a global setting, and can be changed whenever desired, even during an ongoing show. The setting is stored in the system settings and will remain the same until changed, no matter if a new title is loaded.

Using the SpillZone



Pressing the **CONTRIB** key on the ControlBay of any master channel (Aux, Matrix, Grp, Mst, CGM/VCA) will line up all channels assigned to this master bus in the pre-defined SpillZone in the pre-defined direction. The FaderGlow of the spilled-out channels will be lit in the same colour as the colour-code of the spilling master (red for Mst channels, blue for VCA/CGM, orange for Aux, green for Grp). While Spill is active, the **CONTRIB** key will be *flashing*, to clearly distinguish the Spill function from the normal contribution function. Pressing the **CONTRIB** key again will return the surface immediately back to

Nested Spill the show the normal StripSetup.
 If a spilled master has another master assigned to itself, this assigned master channel can spill its members in the same SpillZone by pressing its **CONTRIB** key.

Example : Six input channels (Inp m 1 - Inp m 6) as well as one group channel (Grp st 1) are assigned to contribute to a master channel (Mst st1).
 Further, four input channels (Inp m 7 - Inp m 10) are assigned to the group channel (Grp st 1).

Step 1 Pressing the **CONTRIB** key of Mst st 1 will activate the predefined SpillZone and its members (Inp m 1 - 6 and Grp st 1) will be spilled out there.
 The **CONTRIB** key of the master channel will *flash* to prominently indicate the fact that Spill is active and that the “regular” channels on the surface are no longer visible. The FaderGlow of the spilled-out channels will be lit “red”, because the spilling master channel’s colour code (Mst st 1) is red.

SpillZone after Step 1

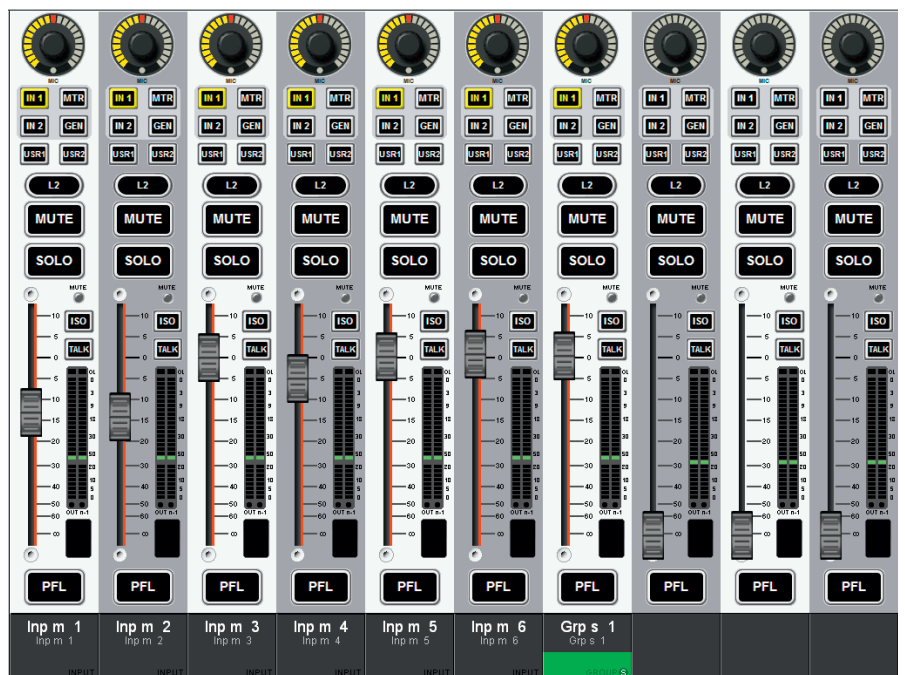

Step 2 Pressing the **CONTRIB** key of the group channel (Grp st 1) from within the SpillZone will overwrite the current SpillZone and reveal the input channels (Inp m 7 - Inp m 10) assigned to the group.
 The FaderGlow of the now spilled-out channels will be lit “green”, because the spilling group masters colour code is green.

SpillZone after Step 2

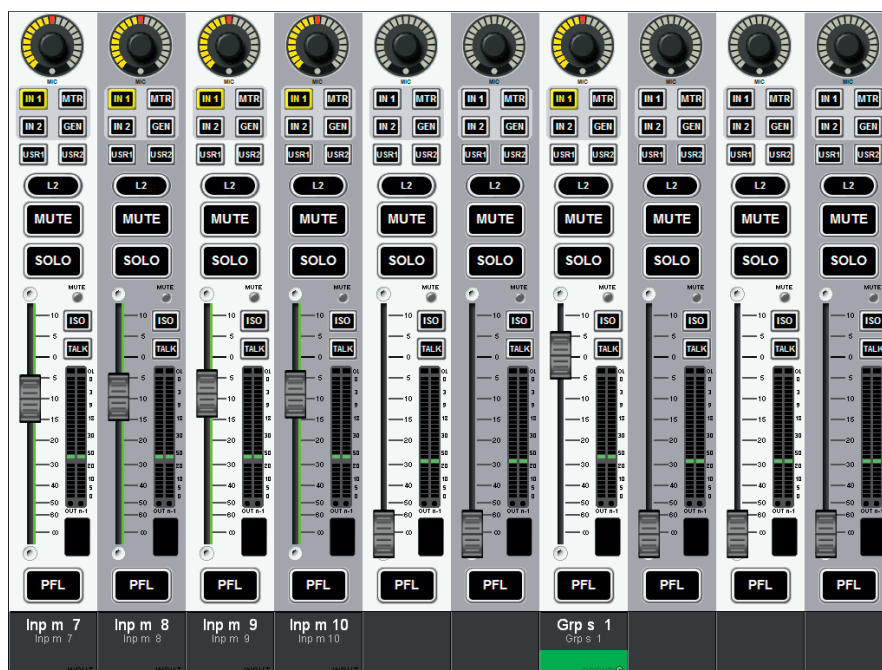

Deactivation of Spill : Any of the following actions will immediately bring the desk back to show the normal StripSetup :

- Pressing the **CONTRIB** key of any spilling master channel a second time.
- Scrolling or changing the fader page on the ControlBay.
- Deleting the SpillZone setup from the Strip-Setup/SpillZone page.

Note : Spill can only be activated from the ControlBay and not from a FaderBay !

2.2.5.19 Follow Solo

By clicking on the newly introduced Follow Solo button in the GC Ribbon tab Tools, category General, the Follow Solo Mode gets activated. This is a global setting which is valid for all titles and remains active until the Follow Solo button is clicked again, even if the Vista application had been closed and restarted in between.

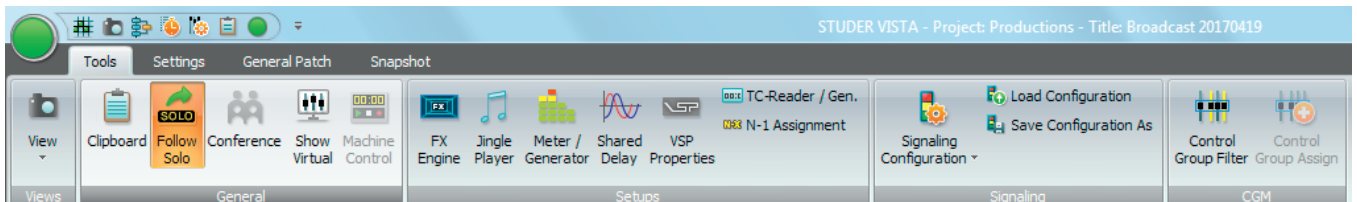

Generally, the Follow Solo Mode is an alternative way of looking at channel contributions to a master. The Vista consoles already allow several different methods to look at channel contributions :

- Send Levels in the Global View.
- Contribution key shows Contribution View on the local Vistonics screen.
- Contribution key with active Spill Zone shows contributing channels additionally in the Spill Zone.

The Follow Solo Mode is the fourth method to look at contribution levels to a specific master channel. It is based on the rule of having master channels in the ControlBay and input channels in the FaderBays. Follow Solo can only be used on master channels (Mst, Grp, Aux). It is triggered by pressing either the PFL- or the SOLO key on such a master channel. Indicated by the flashing PFL resp. SOLO key, all channels in the FaderBays swap their contributing levels to the Fader. In this situation, it is very convenient to listen to the PFL- or SOLO signal of a master, while adjusting the mix with the Faders of the input channels – independent of the type of the master channel (Mst, Grp, Aux). While Follow Solo is active on a master, not only it's PFL resp. SOLO key is flashing, but also the faders that now show the contribution levels are now lit with the FaderGlow-color of the master channel type (Mst = red, Grp = green, Aux = orange).

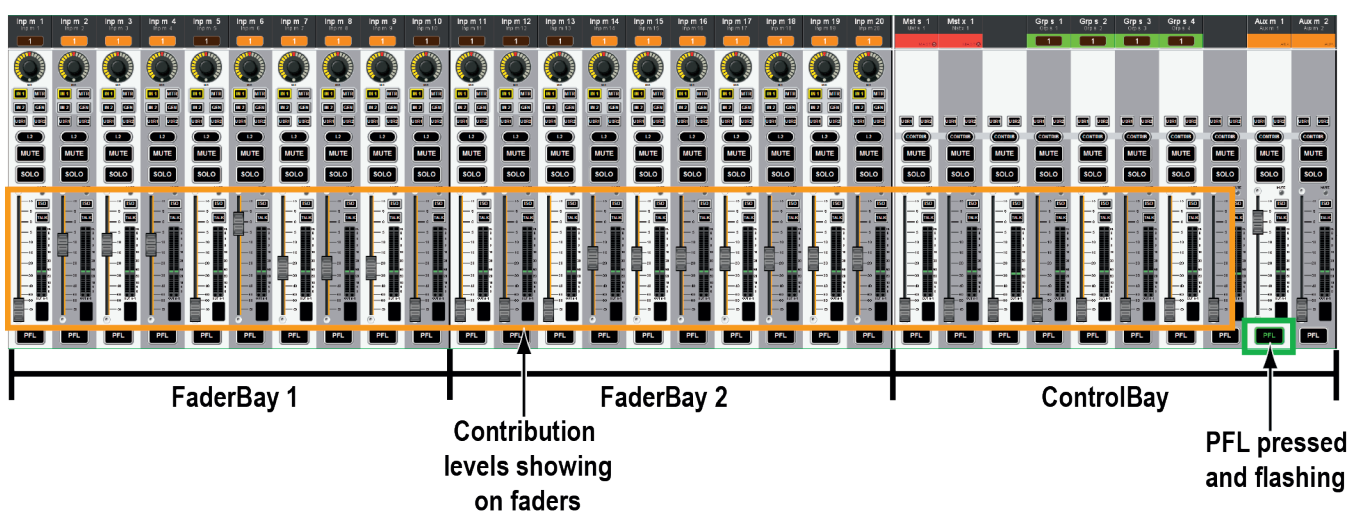

A master is released out of Follow Solo as soon one of the following criteria is met :

- The **PFL** resp. **SOLO** key is pressed again.
- The **PFL** resp. **SOLO** key of a different master channel is pressed.
- The **CLR** key in the monitoring section is pressed.
- Through section navigation, the master channel is not on the desk surface anymore, and therefore the flashing key is not visible anymore.
- The Follow Solo Mode is being disabled in the GC General Ribbon.

Assign Further to showing the contribution levels on the faders, Follow Solo also provides a new tool for bus assigning (or Aux On/Off). With a master in Follow Solo, an **Assign** button is displayed in the Label Area of each channel strip. By touching this **Assign** button, the chosen channel can directly be assigned/unassigned to/off the master bus. The **Assign** button shows the state of bus assign in the same graphical language that the “normal” bus assign view uses. Ganging of several channels can be used to assign many channels at once.

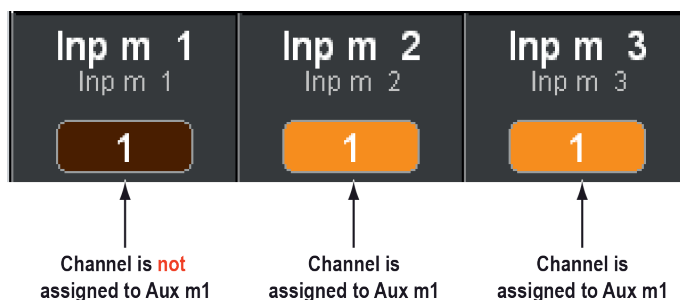

2.2.6 Fader Bay Details

2.2.6.1 Channel Control



Rotary Control

If an analog Studer Mic/Line preamp (either built-in or in a Studer Compact Stage Box) is connected, the analog gain will be controlled before the A/D converters. If not, the rotary control will adjust digital input gain. In any case, further control is available on the Vistonics module. Control of a Studer mic/line preamp is indicated by a small red **MIC** LED at the bottom of the rotary control.

⊕ IN1, IN2

Input Selector. Each channel has three patch points available (the channel patch is visible on the Graphical Controller screen, [chapter 4.4.3](#)). Input 3 is patched to the internal generator's output by default, but can be changed by the user at any time. Only In1 and In2 can be switched directly from within each channel strip. In order to activate In3 (Generator), the user must click on the input switch area of the Channel View window within the Graphical Controller screen, as shown below.

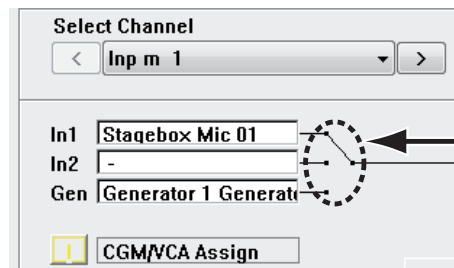

Click here

↓ L2 ↓

(Layer 2 switch) If two-layer mode is enabled, this key switches to view the lower layer of the two.

2.2.6.1.1 Activating Two-Layer Mode

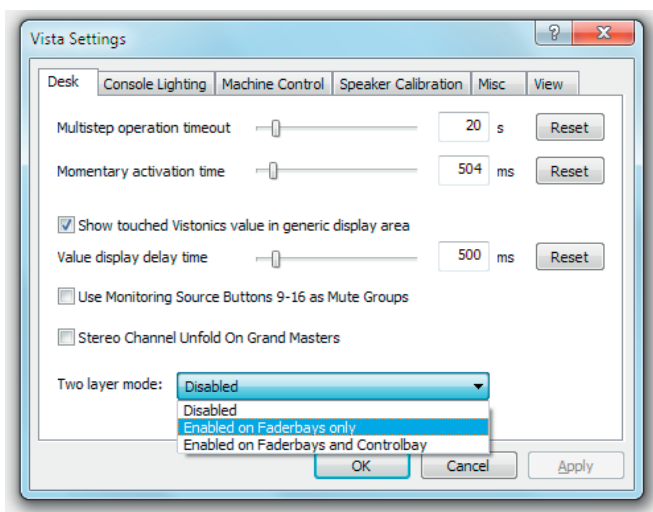

By activating 'Enabled on Faderbays...' in the Option - Vista Settings menu, the virtual desk may be reduced from six to three sections. The previous sections 4...6 now serve as a second (lower) layer of the console.

By pressing the ↓L2↓ key on the channel strips, one individual channel strip can be switched between the upper and the lower half of the console. If a channel strip is currently displaying the third channel of section 1, it will afterwards display the third channel of section 4. This function may be helpful when working e.g. with backup microphones. In this way it is easy to switch to a different channel while leaving the other ones untouched.

Second Layer Disabled (Standard Vista Operation):

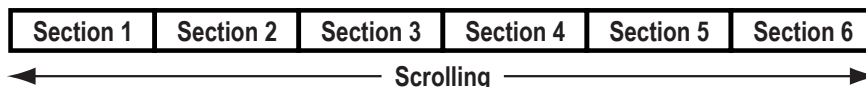

Second Layer Enabled:

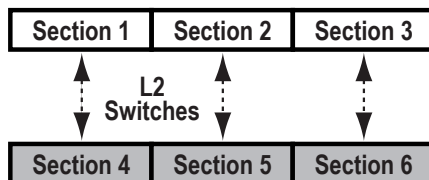

It is still possible to globally switch to the second layer by pressing the section navigator keys 4...6. This will activate the ↓ L2 ↓ keys on each strip of the console surface, indicating that the operator is now looking at the lower half of the console.

Displaying Both Layers at the Same Time:

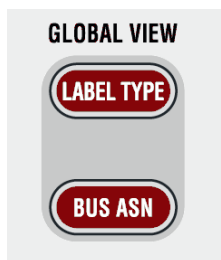

If the second layer option is activated, Vista 1 may display the label and real time metering of both layers at the same time. In order to activate this label view, press **LABEL TYPE** several times until the label display area on the Vistonics screen shows the labels of both layers. This label of the second layer appears only if there is a channel assigned to that strip on both layers. Use the Strip Setup dialog on the Graphical Controller screen to do this. Next to the label there is a small icon showing the level of the alternate layer (below, left). When switched to the second layer, the label lines are swapped, and the top line is showing the first layer label and metering (below, right).

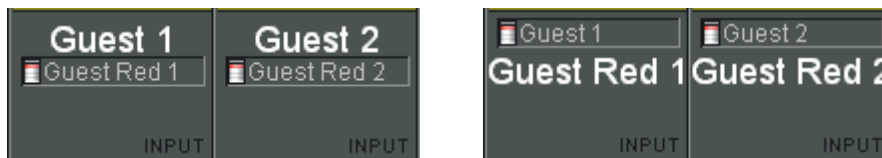

Note: The second layer is displayed only if the first layer is not empty.

2.2.7 Clipboard Libraries

On the Vista console it is possible to save and load clipboards to/from the hard disk or a USB stick. Clipboard files can contain one or more audio functions (e.g. EQ only, Dynamics only, or a combination of EQ and Dynamics) from a channel, or even can save complete channel settings. This is then representing a 'clone' of a channel, including bus assignment. By recalling such a channel from the clipboard library it is easily possible to bring the channels of a console into a certain status without even using snapshot functions.

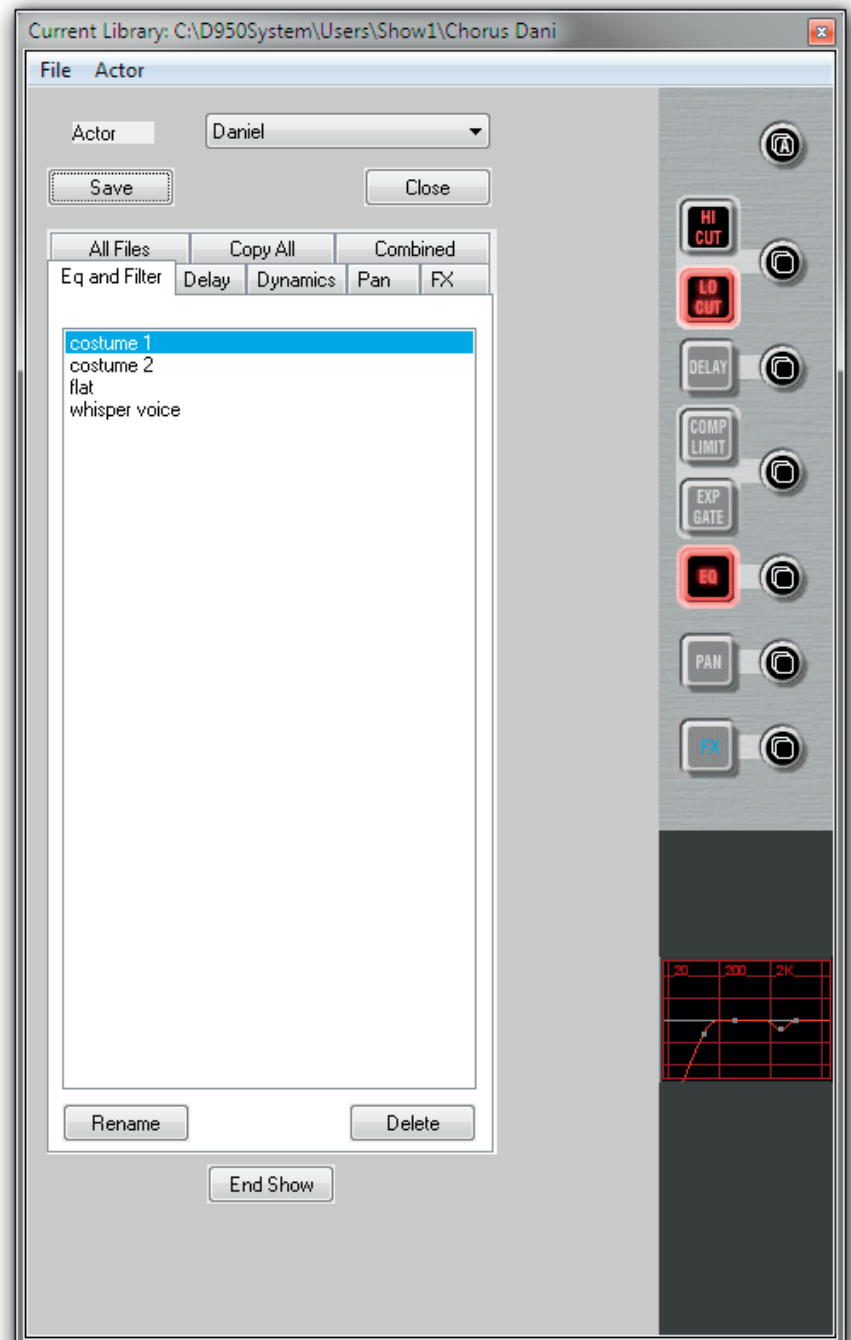

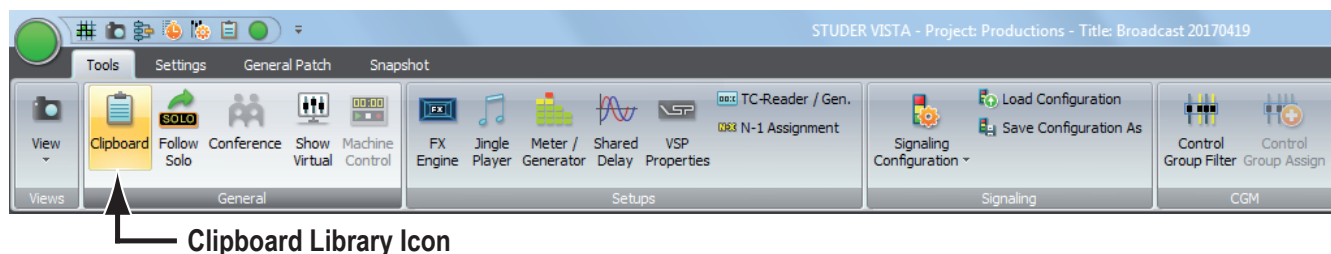

2.2.7.1 Clipboard Library Window

The Clipboard Library window is automatically opened whenever a paste function is pending on the Vista console. In order to open the window manually (e.g., to load the console clipboard with a saved value), select the corresponding icon from the toolbar or press the **OPTIONS F4** key on the console. It is also possible to select the window from the View menu.





The window may be closed by clicking on the close box on the top right corner of the window, by clicking on the Close button, or by pressing **F4** again.

2.2.7.2 Paste to Clipboard Library

- 1 Press the  (Copy/Paste) key on one or more audio functions of any channel strip(s) on the console surface. The Clipboard Library window will be opened automatically whenever a paste operation is pending.
- 2 Click on the half-lit  button in the window. If multiple audio functions are pending to be pasted (e.g. EQ and Dynamics settings), it is possible to click on the half-lit  **A** (Copy/Paste All) button in the window. The pasted values will be graphically displayed.
- 3 The Save dialog opens, now you can give a name to the clipboard. It will be saved in the currently active Clipboard library.
- 4 Close the Clipboard Library window (see above).

2.2.7.3 Copy from Clipboard Library

- 1 Open the Clipboard Library window (see above).
- 2 If the desired library is not opened already (indicated in the title bar of the window), open the requested library by selecting 'Open Library' from the File menu.
- 3 Select the desired tab. Each of them represents a group of saved settings, which means that all listed files within a tab have the same type of audio function settings. 'All files' will show a list of *all* available clipboard files within this library, containing all the content of the other tabs. Files in the 'Combined' tab contain a combination of audio function settings. (e.g. EQ and Dynamics settings together). Files in the 'Copy All' tab contain complete channel settings.
- 4 Select a clipboard setting from the list by clicking on it. This will activate a preview function on the panel, shown at the right-hand side of the window. In this way it is easy to search for a special setting by looking at its graphical representation. The preview function lets you also identify which audio functions are contained in the selected clipboard file: The graphical representation of their 'On/Off' key will be grayed-out if there is no value present in this file.

- 5 Click on the  (Copy/Paste) button of the desired function in order to activate copying. The button will light, and all possible destination keys on the console surface will be half-lit. Shortcut: A double-click on the clipboard name in the list will activate copying of all contained audio values within that particular file directly.
- 6 Paste the value into one or more channels of the console, using the standard functionality. If the clipboard contained multiple audio settings, such as EQ and Dynamics, they may be pasted together by pressing the  A (Copy/Paste All) key of the destination channel.

2.2.7.4 Rename/Delete a Clipboard Library File



- 1 Open the Clipboard Library window (see above).
- 2 Select the file you want to change or delete by clicking on it. Click on the 'Rename' or 'Delete' button of the Clipboard Library window in order to execute the desired action.
- 3 Close the Clipboard Library window (see above).

2.2.7.5 Clear the Display

By clicking on the 'Clear' button, the previewed settings are cleared, and no graphical indication is shown on the right-hand side of the window.

2.2.7.6 Update a Clipboard File

To combine, for instance, the current dynamics settings of a channel with the EQ settings that are already in the library, and to save them as one new set into the library, proceed as follows:

- 1 Open the Clipboard Library window (see above).
- 2 Select the desired, already saved EQ setting by clicking on it once. The EQ settings will be displayed graphically on the right-hand side of the window.
- 3 Press the  (Copy/Paste) key in the dynamics section of the source channel on the console.
- 4 Click on the half-lit  (Copy/Paste) button in the dynamics section of the window.
- 5 Both EQ and dynamics values will now be displayed on the right-hand side of the window.
- 6 The Save dialog opens. Once saved, the new, combined set will now be displayed within the 'Combined' tab.
- 7 Close the Clipboard Library window (see above).

2.2.7.7 Storage Format

Each clipboard is saved in a file with a `.cpy` extension. Multiple `.cpy` files form a library. A `.cpy` file may contain only one audio function (e.g. EQ settings) or a combination of any audio functions of a channel (e.g. EQ and Dynamics settings).

2.2.7.8 Import a Clipboard File from Another Library

- 1 Select 'Import Clipboard' from the file menu.
- 2 Navigate to the desired library.
- 3 Open the desired .cpy file. It will automatically appear and be saved within the currently active library.

2.2.7.9 Where are Clipboard Libraries Saved?

If you don't want to maintain multiple libraries on your console, you never have to change or define a name; just start directly, using the library functionality. The system will then use a library called DefaultClipboardLib.

If there are multiple libraries, you may select 'Open Library' from the file menu of the clipboard window in order to select another library to work with. It is also possible to save the whole library under a different name or to save it to a portable storage device such as a USB stick by selecting 'Save Library' in this file menu. Selecting 'New Library' in the file menu creates a new, empty library.

In technical terms, a library is a subdirectory of the C:\D950\System\Users directory, it may also be located within any other user subdirectory. Selecting 'New User' creates a new user directory containing an empty Library called ClipboardLib.

2.2.8 Console Illumination

Standard gooseneck illumination may be connected to the rear of the Vista 1 desk (3pin XLR in several locations). Brightness may be varied using the 'Option: Vista Settings' menu. There are two separate controls for all console lights (including Vistonics backlights) and for the gooseneck illumination.

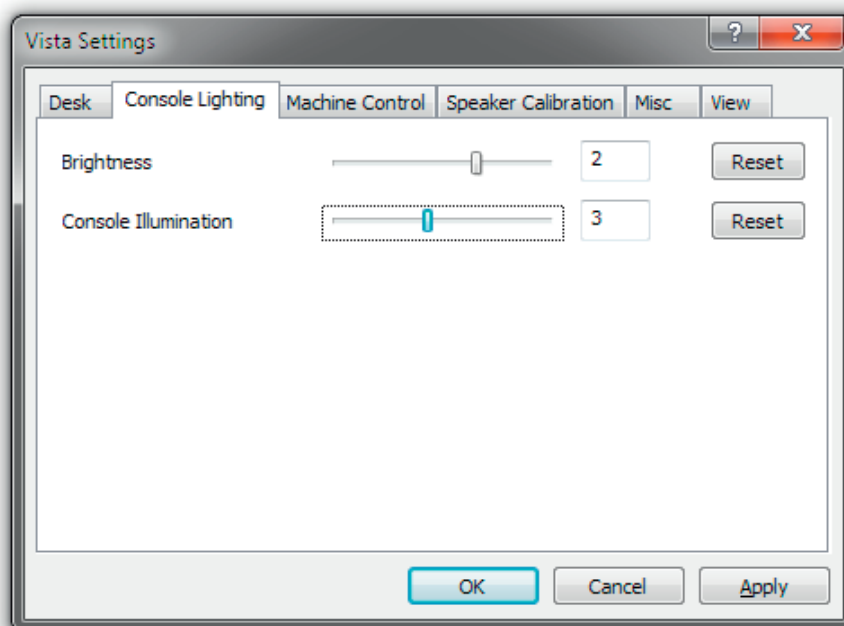

2.2.9 Jingle Player Operation

The integrated jingle player is a stereo playback-only device intended for up to eight different audio clips, such as station identifier jingles, applause etc., that are triggered from the eight keys shown above.

A jingle immediately starts playing upon pressing one of these keys. As long as a clip is playing the key is illuminated. If the key is pressed again while playing, the clip immediately restarts. If a different jingle key is pressed while a jingle is being played, its playback stops, and the new clip immediately starts.

These clip files are usually on a USB memory device (e.g. USB stick) that is connected to the USB socket located below at desk's right below the hand rest, next to the headphones socket.

The jingle player keys have clip-on caps for inserting individual labels mirroring audio file names or key numbers.

On the Virtual Vista application, the jingle player buttons are shown in 'Online' mode only.

Audio File Requirements

The jingle player requires audio files with the following properties:

- USB memory device formatted with FAT32 file system; maximum file size is 4 GB.
- Maximum memory size is 2 TB.
- Wave or broadcast wave format, file extension 'wav'. Please note that files using the *extended broadcast wave files header* are not supported.
- Linear PCM coding; sampling rate 44.1 or 48 kHz; word length may be 16 or 24 bit.

Memory Formatting

Memory devices for use with the jingle player need to be formatted with the FAT32 file system. Some popular formatting utilities will add information that is incompatible with the embedded system of the jingle player.

It is recommended to use the 'Fat32Formatter' freeware tool for formatting your USB devices since it has been tested and is known to perform well. It is available from here: <http://tokiwa.qee.jp/EN/Fat32Formatter/>.

Jingle File Names

Jingle audio files must be located within a root folder named **Jingle** (case-insensitive). If the system cannot find this folder when the memory device is connected, it is automatically generated but will be empty. File names must begin with the character '**J**' followed by a one- or two-digit number (**1-8** or **01-08**) signifying the key it can be started with. The file name extension must be **.wav**. Maximum file name length is limited to 60 characters, extension included.

Examples **J01_Logo_1.wav** is the station logo that is played upon pressing the **JINGLES 1** key.

Note The **J3applause.wav** file is played upon pressing the **JINGLES 3** key. If two files should be present the names of which both begin with the same key number (such as **J3_applause_44.1k.wav** and **J3_applause_48k.wav**), the key assignment is undefined. When pressing the **JINGLES 3** key, any of the two files may be played then.

As soon as a USB memory device is connected to the system, all **.wav** files meeting the name convention are verified. Files that cannot be played as they do not meet the system requirements or have a corrupted file header cannot be selected.

Input/Strip Mapping

The jingle player can be assigned to a channel strip in the same way as any other input. It can be selected and patched like an input source in the Graphical Controller.

JINGLES Desk Keys

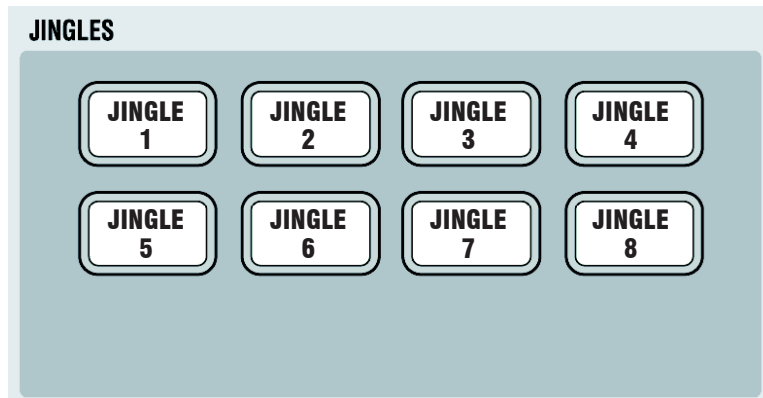

The **JINGLE 1-8** desk keys become active as soon as a USB stick containing valid jingles is inserted to the USB socket below the desk's hand rest. Upon pressing one of the keys, the corresponding jingle audio file starts playing immediately, and the key is illuminated while playing. When pressing a different jingle key while a jingle is currently playing it is interrupted and the new jingle starts immediately. When pressing the key of a jingle that is currently playing, it immediately restarts from the beginning.

The default jingle key labels are shown above; the keys have transparent snap-on caps for easy relabeling.

GC Jingle Player Window

Since the **JINGLES** desk keys cannot be dynamically labeled, a Jingle Player window was added to the Graphical Controller.

It is opened by a click on the Jingle Player button in the GC Ribbon tab Tools, category Setups.

Please note that the Virtual Vista application only shows this Jingle Player window when in 'Online' mode, i.e., when connected to a console and switched online.



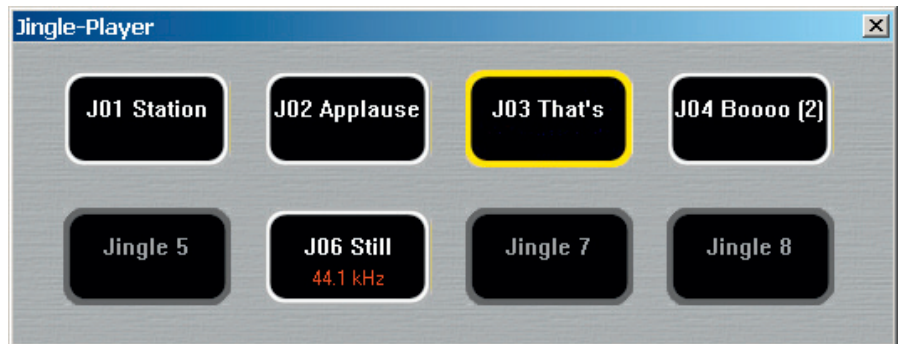

The eight **Jingle** buttons mirror the desk hardware jingle keys. Upon insertion of a USB stick, the valid jingle files are assigned to the **Jingle** buttons. A click on a button triggers playback of the corresponding audio file, the same way as the corresponding desk key would.

This may also be used in a two-operator situation for triggering jingles from the desk and from the Virtual Vista application or the Vista Compact Remote Bay.

After removing the USB stick, the **Jingle** buttons are grayed out and indicate their number only.

The **Jingle** buttons indicate different statuses of the USB stick and the audio files as follows:



No Jingle audio file is assigned to the button, i.e., the appropriate audio file is missing or invalid. The button label shows **Jingle n**; the button has no function.



A valid jingle audio file is assigned to the button. The button label shows the name of the pre-loaded jingle file, the button is enabled.



The audio file assigned to the button is currently playing. The button label shows the name of this jingle file. The button is enabled, a next click on the button will immediately restart the same audio file.



An audio file is assigned to the button, but it has a sampling rate different from the one of the system. The button label shows the name of the pre-loaded jingle file, and on the second line the audio file's correct sampling rate in red. The button is enabled. A click on the button starts playback, but with a wrong speed and pitch.



An audio file having a sampling rate different from the one of the system is currently playing, having a wrong speed and pitch. The button label shows the name of the playing jingle file, plus the audio file's correct sampling rate in red on the second line.

2.2.10 FaderGlow®

The fader tracks (including the ones of the Grand Master faders) can be illuminated in any of eight available colors, based on function or session context. This color is repeated on the meter screen for additional clarity.

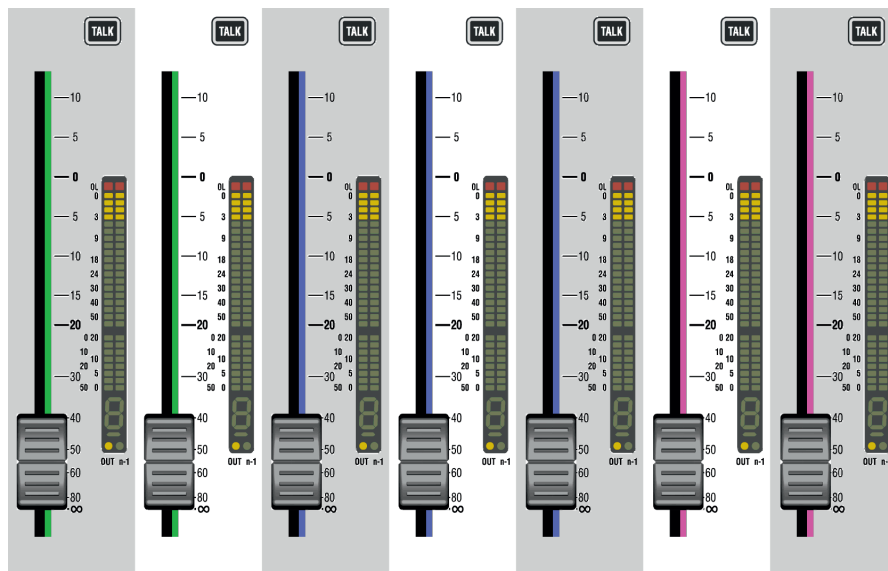

The logical place for assigning FaderGlow colors is the Strip Setup, where the layout of all channels on all six sections is shown; for setup details refer to [chapter 4.4.6.1.7](#).

The FaderGlow setup is saved as a part of the Strip Setup, allowing different operators who might alternately mix a show having their own, personal color setup.

2.2.11 Optional TFT Level Meters

Depending on console size, the TFT meterbridge features between two to five screens dedicated to the metering. One more screen is used for displaying the GC information. Therefore no external GC screen is required when using the TFT meter option.

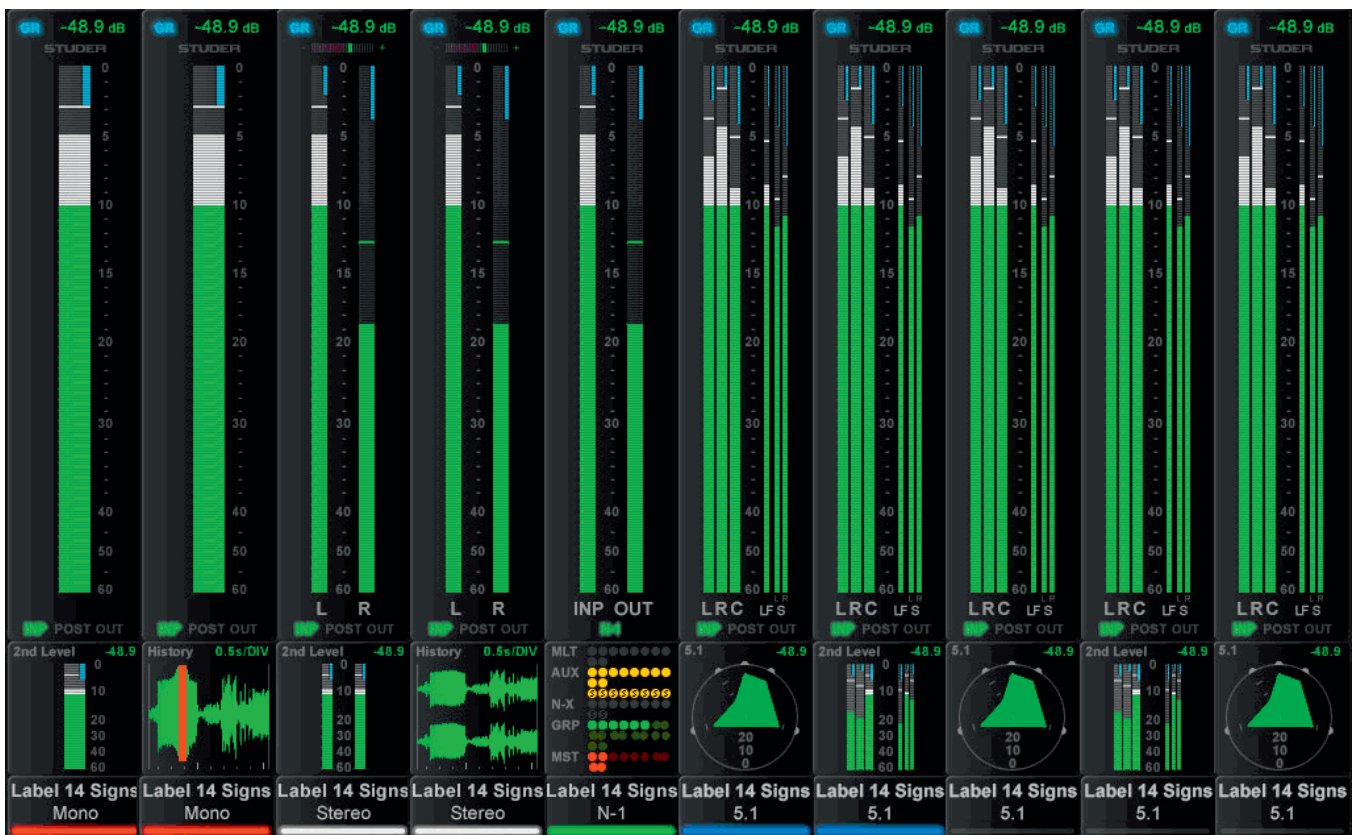

For all possible channel types - mono, stereo, 5.1 - the metering goes with it, as shown above. Priority was to have as large a bar graph meter as possible. The lower area is configurable for displaying different options, depending on the channel type, such as a surround image view, or a history diagram of incoming or outgoing signal waveforms, for spotting anomalies in the audio signal, such as overloads or signal loss.

Another option in the lower portion of the TFTs is a bus assignment view, giving an overview of the channel's current bus assignment, e.g. on a single channel where bus assignment is changed frequently.

The control bay metering differs in that it is mainly made to show output channels. More views are available, e.g. all AUX outputs, all groups, all programme masters, direct outputs, bus outputs, N-1s, matrix channels, etc. Four user pages can be configured. One has ten slots in one row, one 20 slots in two rows, and two have 40 half-width slots in two rows. The two slots at the right of the control bay TFT screen continuously show PFL and CR levels.

The illustration on the previous page is an example of a meter screen with mono, stereo and surround channels and different views in the lower area – such as metering of the L2 channel, history, bus assignment and surround view. Further information is displayed as well, such as gain reduction or surround signal type.

Level Meters

The level meter bargraphs indicate digital peak values including headroom of mono, stereo, 5.1 and N-1 channels. The meter scale always is in dB_{FS} with 0 dB_{FS} at the top, with an additional overload segment clearly indicating overloads. Stereo meters feature a correlation meter on top of the meter bars, both on stereo inputs as well as on stereo master channels.

Above the level bargraph area gain reduction meters are added. Clipping is

displayed by turning the white bargraph section (i.e., the segments above the headroom threshold) to red. The meter tap point can be selected from input, post fader and direct output level of the corresponding channel. It is possible to use the red overload indicator above the meters to indicate a level just entering the configured headroom, rather than clipping. This is set in the GC's 'Meter/Generator' window.



The area below the large bargraphs provides additional visual information, depending on the channel type and on what the operator prefers to see. When the desk is in 'two layer' mode, a smaller bargraph meter of the L2 channel (e.g. a spare microphone) is always shown.

Furthermore there is the option to display the audio waveform of the signal that has passed the channel, so the operator can see the history of the audio back to a configurable time of up to 50 seconds. The waveform of the audio-signal not only gives very clear information about signal loss or overload (which colours that part of the waveform in red) but also indicates the character of the signal, as in the age of DAWs most operators are used to interpret signals by looking at their waveform. The speed of the meter history view can be set in the Metering & Generator Settings window, as shown below.

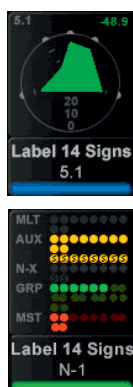
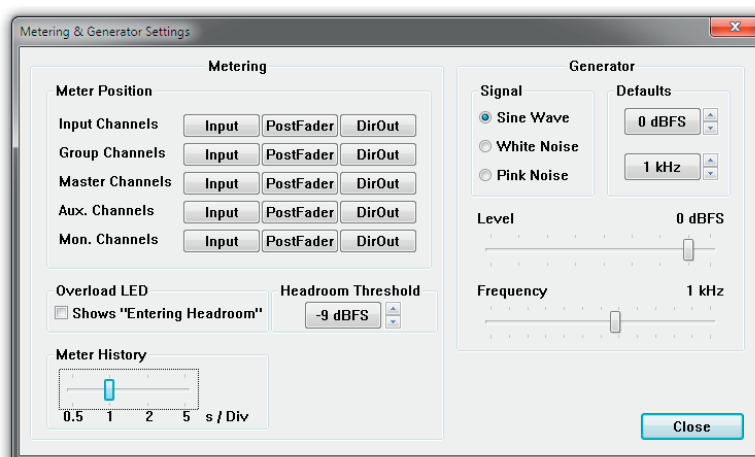

Surround channels come per default with a surround image view in the lower area, offering a spatial visualization of the surround signal. It allows spotting anomalies in a surround signal much faster than any other method.

Alternatively, a bus assign view can be selected on any channel, giving a nice overview of the bus routing right below the bargraph meters. This may not be sensible for every channel but is useful for the ones where the bus assignment is changed frequently.



Control Bay The control bay TFT metering is of multiple use. The **VIEW** keys *together with the \hat{u} (shift) key* allow switching between different views. All **VIEW** keys are of the momentary/latching type.

The **FOLLOW** key displays the metering that belongs to the channel assigned to the desk surface.

Then, there are view keys for all different type of master channels: Aux, Groups, program Masters, Matrix, etc., as well as output meter views of multitrack and n-1/x busses.

Moreover, there are four user keys that allow displaying any choice of channels of the mixing console on the four user pages. For assignment there is a page on the GC's Strip Setup window that lets assign up to 10 channels on the **USER 1** page, up to 20 channels in two rows on the **USER 2** page, and a maximum of 40 half-width channels in two rows on both the **USER 3** and **USER 4** pages.

The two meter slots at the right of the control bay TFT screen, however, continuously show PFL and CR levels.

Setup TFT meter bridge setup information is given in [chapter 4.4.6.1.6](#).

2.2.12 Virtual Vista

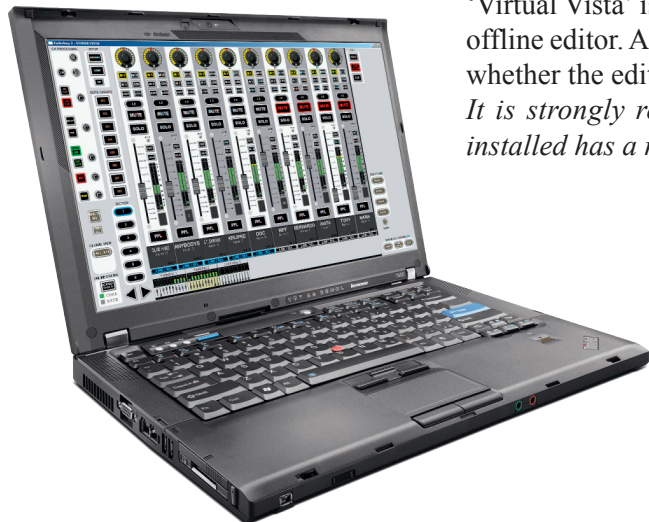

‘Virtual Vista’ is a Windows application that can be used both as online and offline editor. An indicator visible on all fader and control bay screens shows whether the editor is currently online (connected to a desk), or offline.

It is strongly recommended that the computer on which Virtual Vista is installed has a minimum screen resolution of 1440 × 900 pixels.

Operating Modes

With the Vista1 and its built-in DSP Core, only the offline operating mode is possible for the Virtual Vista. With Vista systems that have a separate DSP core, there is also the possibility of using the Virtual Vista in online mode.

Offline



The offline editor is intended for setting up, preparing or changing shows without having access to the actual console. All parameters can be controlled. However, when working offline, no access to the monitoring facilities is available.

2.2.12.1 Screen Layout

Since the Vistonics screen picture already uses 1024×768 pixels and additional space is required at the sides of and below the Vistonics screen area, the screen resolution should be at least 1440×900 pixels in order to display the complete Virtual Vista screen.

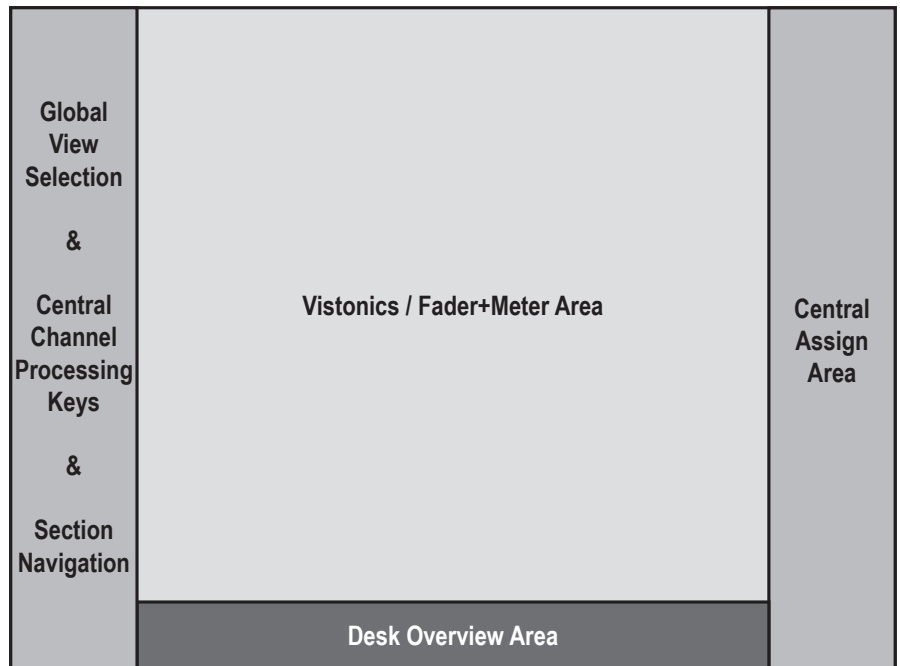

The space below the Vistonics screen area (desk overview area) is used to display a downsized overview of a virtual desk with up to 72 faders. This is the maximum possible desk size so that all possible titles can be viewed with the original strip setup and desk layout.

The area to the left of the Vistonics screen area shows the global view selection as well as central channel processing buttons (as used in Vista 1 and 5). Section navigation is at the bottom of this part. It will change depending on whether a fader bay or a control bay is currently selected.

On the right side of the Vistonics screen area a central assign fader strip is shown. It will change, too, depending on whether a fader bay or a control bay is currently selected.

The online/offline editor cooperates with Vista 1 (22 or 32 faders), Vista 5 (22, 32 or 42 faders) as well as with the modular Vista 7, Vista 8 and Vista 9. For screen space considerations, mostly the Vista 5 operating concept is applied.

2.2.12.2 Fader Bay View

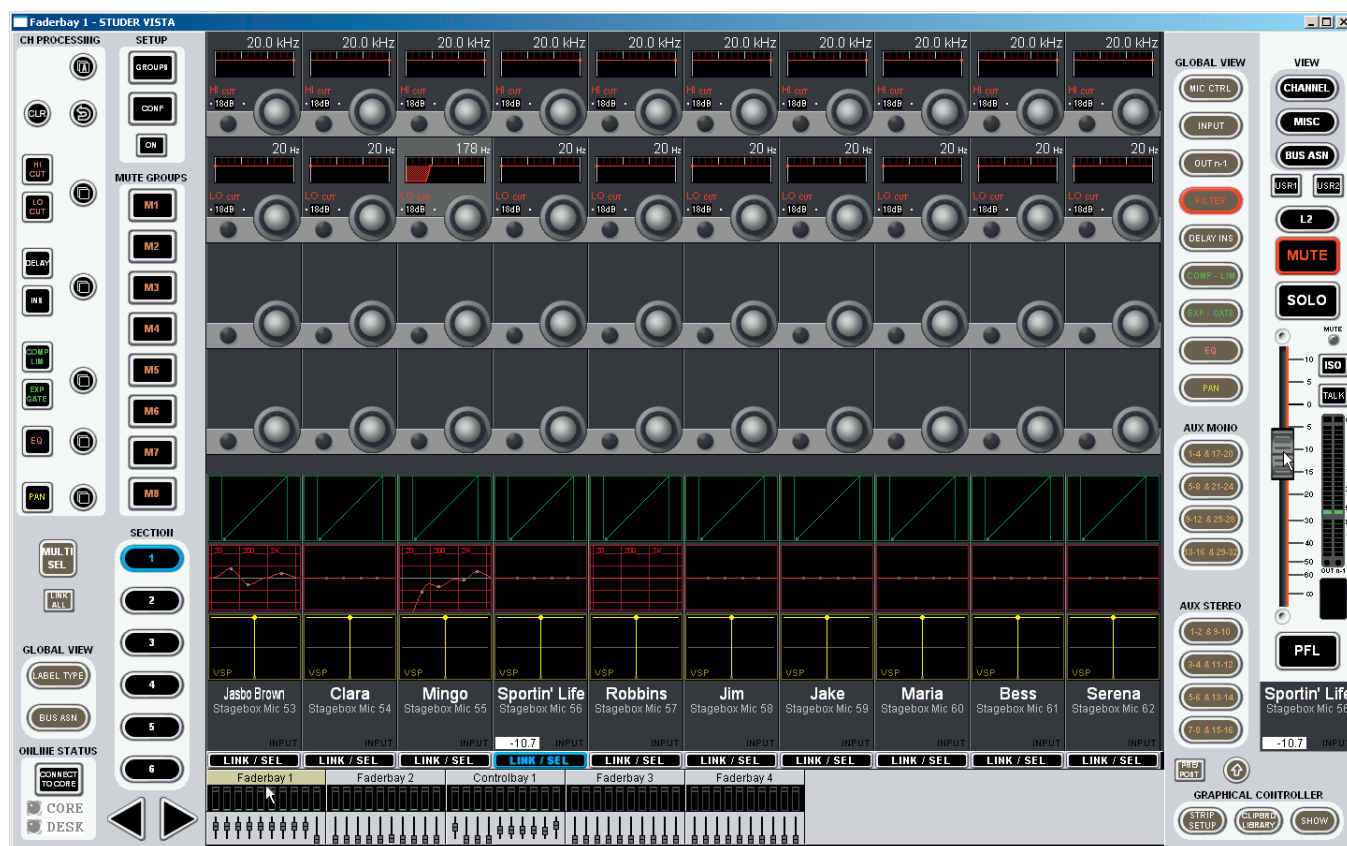

By clicking into the *meter area* of one of the fader bay icons (Faderbay 1...), the corresponding Vistonics view opens up. The upper part of the selected fader bay icon is highlighted in order to make clear which bay the operator is looking at.

The **LINK / SEL** buttons below the label area of the Vistonics screen are used to assign one of the faders to the single central fader that is displayed at the right edge. As long as this fader's knob is 'touched' (i.e., the mouse pointer is located upon it and the left mouse button is pressed), the current fader value is displayed in both channel label fields, as shown in the screenshot above. If FaderGlow is active, this is reflected on the central fader as well.

Channel Grouping (Ganging)

The **MULTI SEL** button allows grouping channels for parallel operation. If a channel is selected with its **LINK / SEL** button, a click on **MULTI SEL** followed by a click on the next desired **LINK / SEL** button builds a two-channel group; a third channel is added to the group by another click on **MULTI SEL** and the next **LINK / SEL** button, and so on, until all the desired channels are grouped. The other way round, a click on **LINK ALL** and any **LINK / SEL** button selects all currently displayed channels; then, using the **MULTI SEL** and **LINK / SEL** buttons allows removing channels from the group.

There is a different, convenient way for building a channel group (or gang): Left-click-and-hold a **LINK / SEL** button, then – while still holding the left mouse button – right-click on another one. This will add all **LINK / SEL** buttons between the selected ones to the group. This works, by the way, also when right-clicking-and-holding first and left-clicking afterwards.

By clicking into the *fader area* of one of the fader bay icons (Faderbay 1...), the ten corresponding faders are shown instead of the Vistronics screen. The central fader on the right is then hidden. The lower part of the selected fader bay icon is highlighted – in order to make clear which bay the operator is looking at.



Operation The *hardware keys and buttons* (also the keys next to the rotary encoder knobs) on the screen can be operated by clicking on them either with the right or left mouse/trackball buttons.

Rotary encoder knobs can be operated by clicking-and-holding them with the left mouse/trackball button (this corresponds to touching the real encoder knob on the desk surface); the parameter value is then underlined and displayed below the label area in addition. By moving the mouse to the right or upwards (or anything in-between) the parameter value is increased; by moving it to the left or downwards, the parameter value is decreased correspondingly.

2.2.12.3 Control Bay View

The control bay view can be selected from the desk overview area at the bottom of the screen. By clicking into the *meter area* of the control bay icon (Controlbay 1), the corresponding Vistronics view opens up, as shown below. The upper part of the selected control bay icon is highlighted in order to make clear which bay the operator is looking at.

The **SECTION** navigator changes to the four-**FADER PAGE** navigator used in the control bay view. The global Vistronics **VIEW** selector of the control bay is shown next to the central fader.

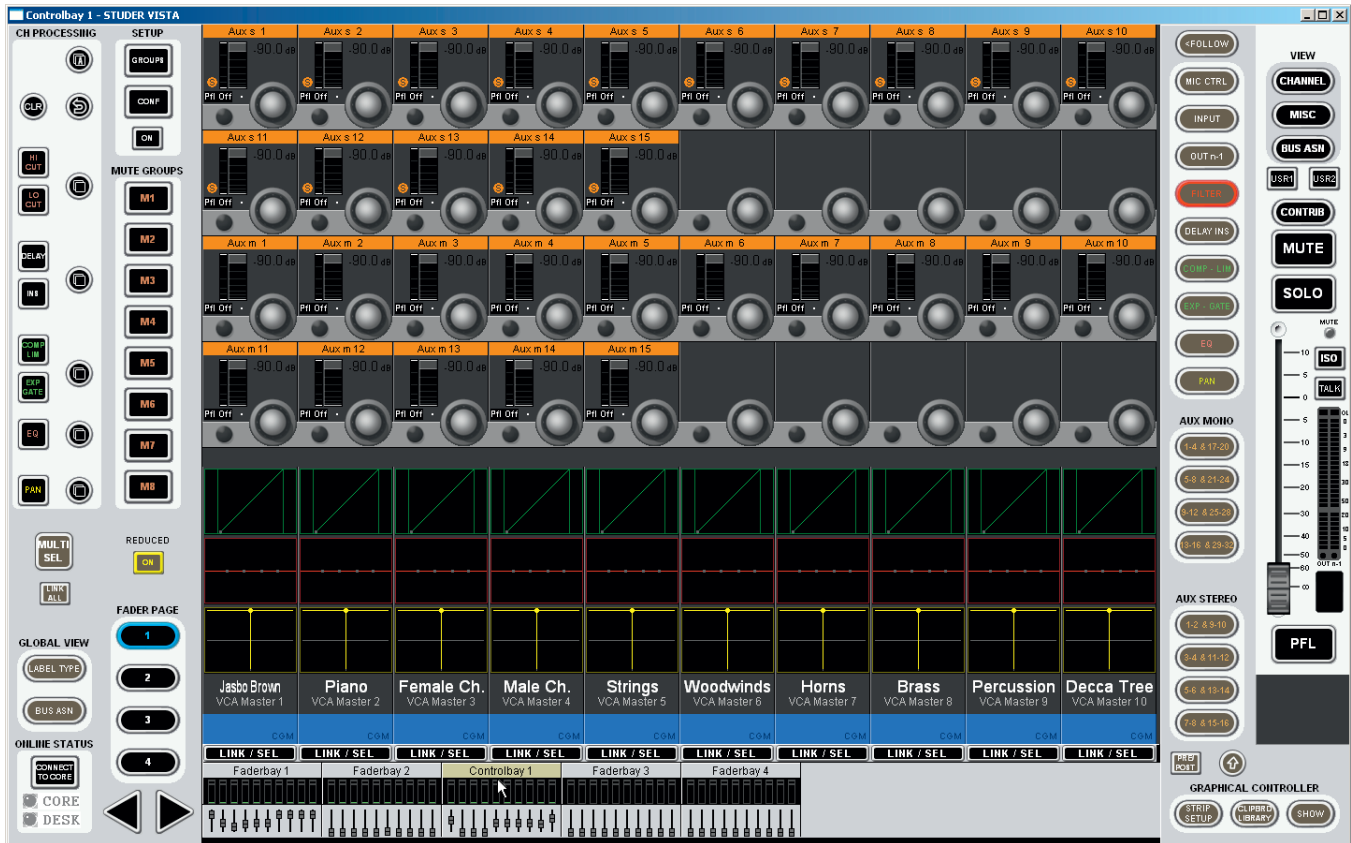

By clicking into the *fader area* of the control bay icon in the desk overview area, the ten faders of the control bay are shown. At the right of the screen the two **GRAND MASTER** faders are displayed.

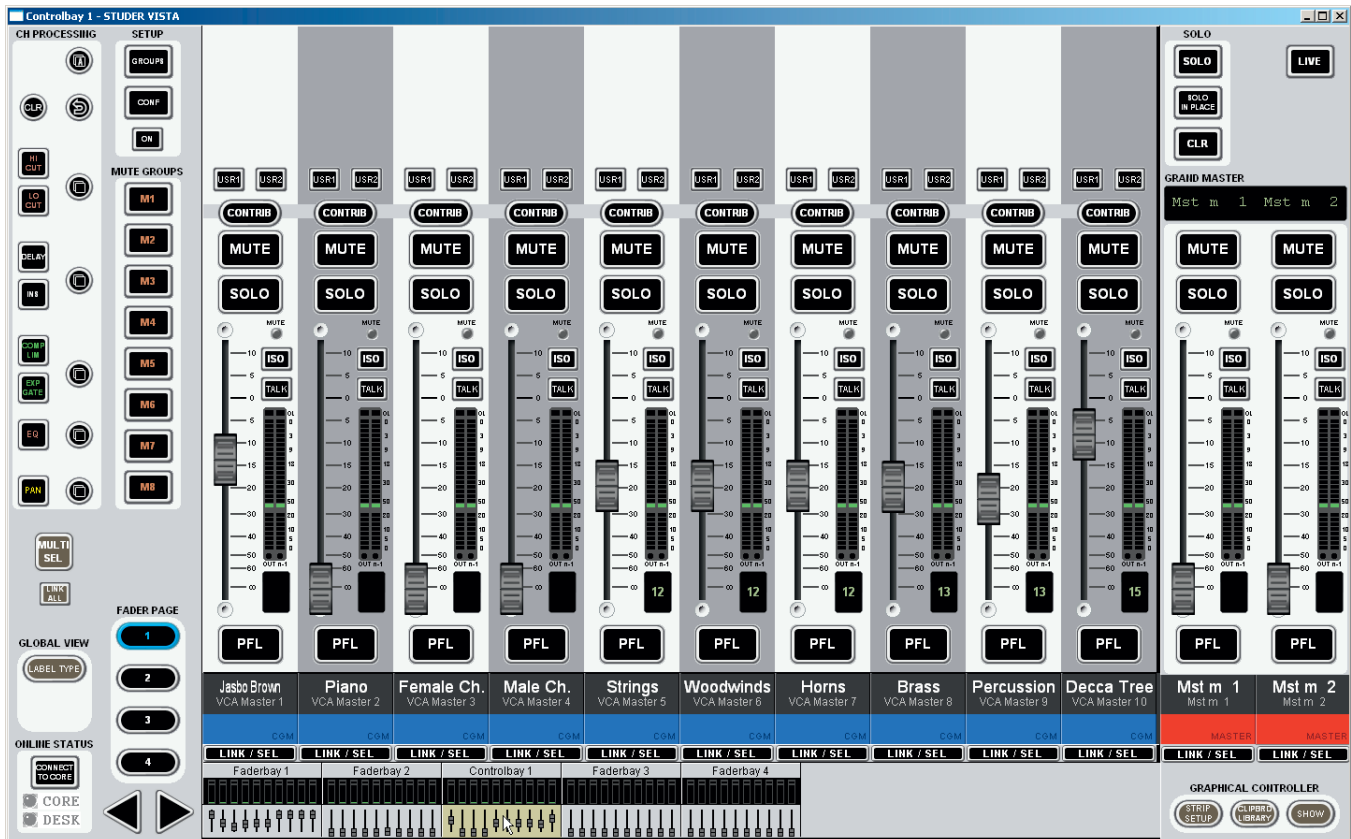

2.2.12.4 GC View



The GC general patch view opens after a single click on the **GRAPHICAL CONTROLLER – SHOW** button (at the bottom right of any of the fader and control bay windows), or by a click on in the taskbar, followed by a click on the general patch icon.

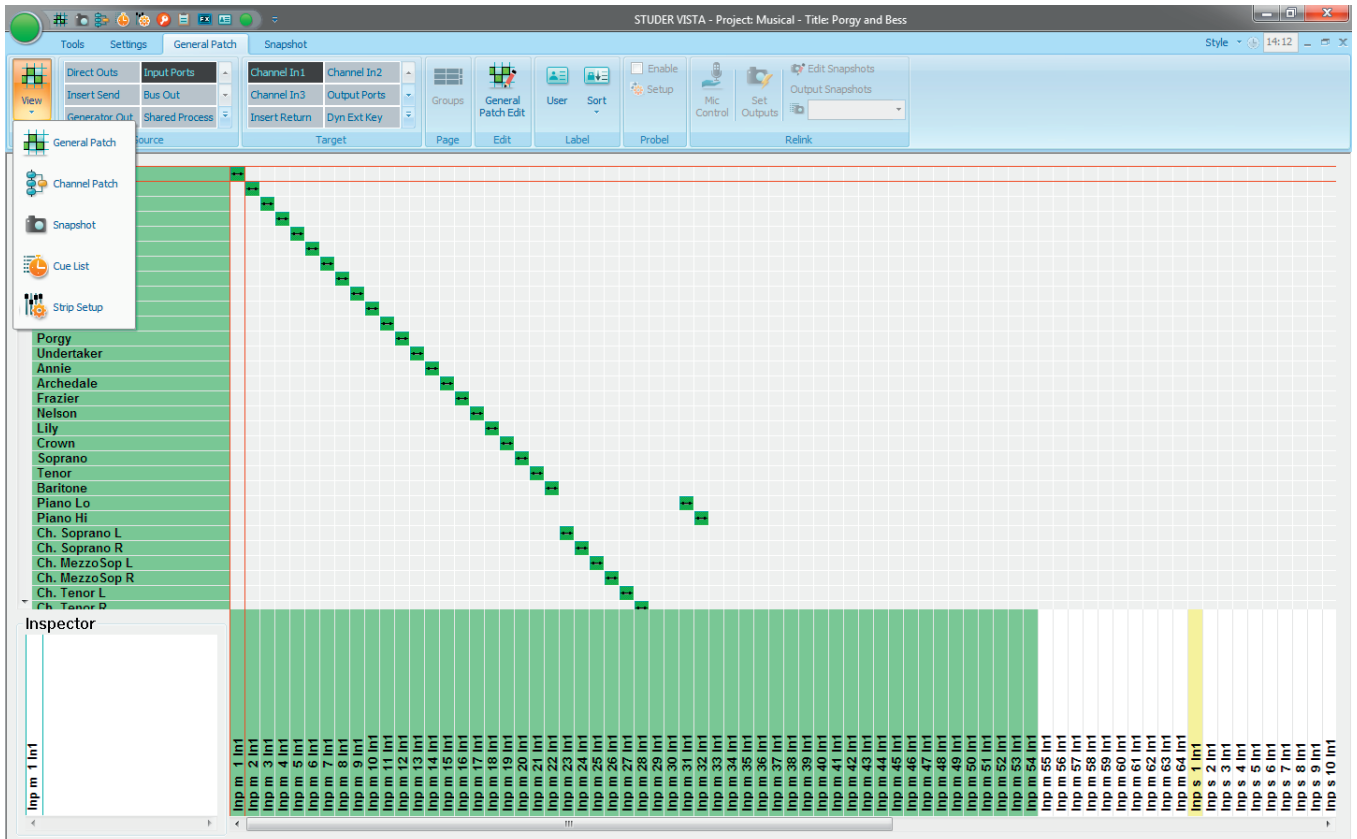

There are two other shortcut buttons: In order to have the clipboard library window displayed in front of the general patch view, click the **GRAPHICAL CONTROLLER – CLIPBRD LIBRARY** button; in order to have the strip setup window displayed in front of the general patch view, click the **GRAPHICAL CONTROLLER – STRIP SETUP** button.

In order to have the theatre cue list displayed, click on the cue list icon. The other icons (- channel patch, - snapshot, - strip setup) work in the same way.

CHAPTER 3

3	Vistonics Parameters	3
3.1	Introduction	3
3.2	View Changes	3
3.2.1	Global View Change	3
3.2.2	Channel View Change.....	4
3.3	Global Views	5
3.3.1	Input Parameters.....	5
3.3.2	Pre-Amp Remote Parameters	8
3.3.3	Direct, Multi-Track and N-1 Output Parameters.....	10
3.3.4	Mono AUX Parameters	11
3.3.5	Stereo AUX Parameters	12
3.3.6	Filter Parameters	13
3.3.7	Delay and Insert Parameters.....	14
3.3.8	Dynamics Parameters.....	16
3.3.8.1	Compressor / Limiter Parameters	16
3.3.8.2	Expander / Gate Parameters	18
3.3.9	Parametric EQ Parameters	20
3.3.10	Graphic EQ Parameters.....	21
3.3.11	Panning Parameters.....	21
3.3.12	Global View of 5.1 Surround Input Channels	22
3.3.13	Global Bus Assignment View	23
3.3.14	Generic and Label Display Area	24
3.4	Channel-Related Views	25
3.4.1	Parametric EQ and Filter Parameters.....	25
3.4.2	Graphic EQ Parameters.....	27
3.4.3	Dynamics Parameters.....	29
3.4.3.1	Standard Dynamics	29
3.4.3.2	Standard Dynamics for 5.1 Surround Channels.....	33
3.4.3.3	Vintage Dynamics	35
3.4.4	Panning Parameters.....	37
3.4.4.1	Amplitude Panning Parameters.....	39
3.4.4.2	Upmix Panner Parameters (for Stereo Channels only)	41
3.4.4.3	Multi-Format Panning Parameters	42
3.4.4.4	VSP Panning Parameters.....	44
3.4.4.5	Panning Parameters for 5.1 Surround Channels	46
3.4.4.6	Microphone Simulation Tool (MST) – User Pan Mode.....	48
3.4.5	VistaMix (VMX).....	51
3.4.6	Channel View in general	55
3.4.7	Channel View - Stereo Channel	56
3.4.8	Channel View - 5.1 Surround Channel	58
3.4.9	Misc View (Miscellaneous Parameters)	62
3.4.10	Bus Assignment View	63

3 VISTONICS PARAMETERS

3.1 Introduction

The desk can show different audio controls on the Vistonics™ screens. The controls differ in type of graphical viewing, shapes, and colors. If required, they are grouped together with frames in order to give the user maximum information without the need to read text on the display. The view of the audio controls can be changed either globally for the whole console, or locally, i.e. for one single channel.

3.2 View Changes

3.2.1 Global View Change



When pressing one of the keys in the **GLOBAL VIEW** areas, the default view of the fader bay is changed. The control bay remains with its own view unless **FOLLOW** is active. Each channel strip can show parameters on up to four rotaries and their associated key. Only one global view key can be active at a time.

Some views will not cover all four rotaries, depending on the function (e.g. a 2-channel pan covers only the bottom rotary) or the currently active DSP configuration (e.g. if only 3 mono AUX busses are configured). After a view is activated, the corresponding key is lit. When this key is pressed again, all previous views (i.e., the ones other than the currently pressed global view key) will be blanked. So the selection of parameters can be done in a quite flexible way. When pressing **AUX MONO 1-4** followed by **PAN**, the result will be AUX 1-3 on rotaries 1 through 3, and pan on rotary 4. When pressing **PAN** a second time, rotaries 1 through 3 are blank and pan will still be displayed on rotary 4.

No rule without exceptions:

- Some of the **AUX MONO** or **AUX STEREO** keys may be without function; this depends on the currently loaded configuration.
- When the **PRE / POST** key in the fader bay's **GLOBAL VIEW** area is active, the AUX views change to pre-/post-fader selection.
- As a special global view change, the **GLOBAL VIEW: BUS ASN** key lets the EQ, Dynamics, and pan curves on the lower part of the TFT display disappear and shows all bus assignments instead (see chapter 3.3.13). Pressing **GLOBAL VIEW: BUS ASN** again makes the curves reappear.

3.2.2 Channel View Change

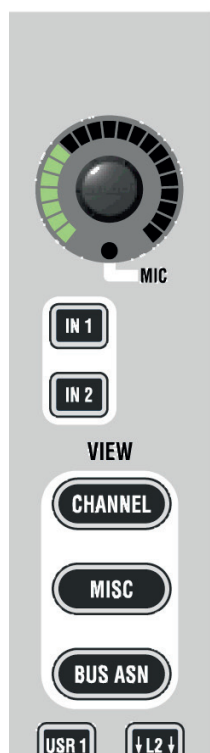

The views listed below can be activated in each channel strip. Then the corresponding values of this particular channel are shown.

- Dynamics (by touching the green dynamics view on the screen)
- EQ (by touching the red EQ view on the screen)
- Panning (by touching the yellow pan view on the screen)
- Bus Assignment (by pressing **VIEW: BUS ASN** – as opposed to the **GLOBAL VIEW: BUS ASN** key described in [chapter 3.2.1](#)).
- Channel parameters (by pressing **VIEW: CHANNEL**); this shows the remaining controls together with AUX and covers all 40 rotaries.
- Miscellaneous parameters (by pressing **VIEW: MISC**); this shows a reduced view of EQ, dynamics, and pan parameters at the same time; it covers all 40 rotaries.

When touching a curve on the TFT, a picture with the available parameters appears on the rotaries. The picture is 'left-aligned' to the selected channel. When touching the dynamics curve of the third channel strip, for instance, the corresponding graphics are shown on the rotary rows 3 through 7, since the dynamics parameters are covering five rows of rotaries. While the function is unfolded on the display, the corresponding graphic field (e.g. showing the dynamics curve) is highlighted, as shown in the picture at the left.

On one Vistonics screen, two audio functions can be shown at a time, either by using the **MULTI SEL** key, or by simultaneously touching two graphics. In this case, one of the two functions is displayed left-aligned, the second one right-aligned. If there is any room between them, they are interleaved by one or more strips in black. The rotaries on these blackened strips are not used.

3.3 Global Views

3.3.1 Input Parameters

Press **GLOBAL VIEW: INPUT GAIN**.

For input sources IN 1, IN 2, and GEN (selection with the hardware keys below the channel meters), an input control view is available. The number of functions available on Input or Output channels, as well as on mono or stereo channels, depends on the currently loaded configuration.

A DC reject filter is always active in each channel.

For input and output channels, the following parameters are available:

Parameters	MONO INPUT			STEREO INPUT			MONO GROUP			STEREO GROUP			MONO/STEREO MASTER			MONO/STEREO AUX		
	IN1	IN2	GEN	IN1	IN2	GEN	IN1	IN2	GEN	IN1	IN2	GEN	IN1	IN2	GEN	IN1	IN2	GEN
PHASE	X	X	X	X	X	X	X	X	X	X	X	X	-	-	-	-	-	-
XY/MS-MODE	-	-	-	X	X	-	-	-	-	X	X	-	-	-	-	-	-	-
INPUT MODE	-	-	-	X	X	-	-	-	-	X	X	-	-	-	-	-	-	-
INPUT GAIN	X	X	X	X	X	X	X	X	X	X	X	X	-	-	-	-	-	-

Mono Channel: Stereo Channel:



Input Parameters for Mono Channels *only*:

- PHASE** Two positions are provided (select either with the key or the rotary):
- NORM/Off, in phase (default setting).
 - REV/On, out-of-phase.

Input Parameters for Mono *and* Stereo Channels:

- GAIN** Input gain can set in 1 dB steps from -24 dB (attenuation by 24 dB) to +24 dB. Default value: 0 dB.
- In a stereo channel, left and right input gains are treated simultaneously.

Input Parameters for Stereo Channels *only*:

Input Gain Unfold Please note that when using **VIEW: CHANNEL** to access the input gain of a stereo channel, it is possible to adjust the input gain of each signal leg separately. See [chapter 3.4.7](#).

- PHASE** Four different positions are provided:
- ++, in phase (default setting).
 - -+, left channel (or input A) out-of-phase.
 - +-, right channel (or input B) out-of-phase.
 - --, left and right channels (or inputs A and B) out-of-phase.

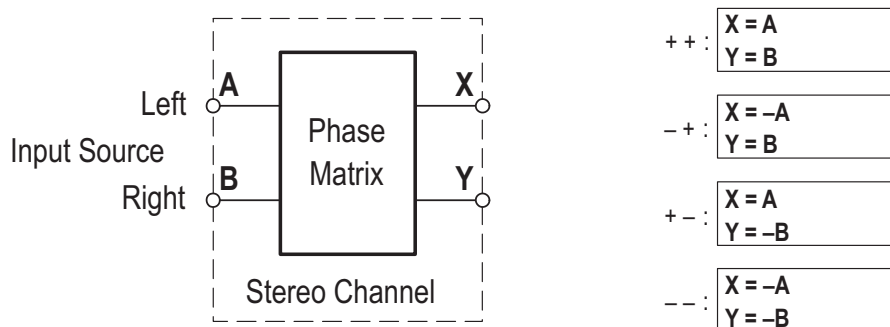

- MS on/off** Two different positions are provided:
- MS off (default setting), for coincident XY stereo microphone setups.
 - MS on (Mid/Side information), used for decoding MS information from appropriate coincident stereo-microphone arrays.

- 2 CH MODE** Five different positions are provided:
- Stereo (default setting).
 - Left and right signals are swapped.
 - Left signal only is routed to both left and right outputs.
 - Right signal only is routed to both left and right outputs.
 - Mono, left and right signal mixed together (-3 dB) and routed to both left and right outputs.

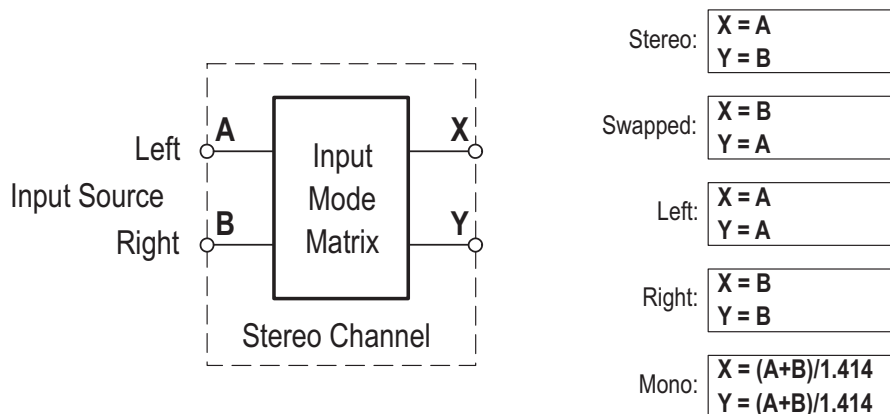

If a channel contains the input balance function, a balance control will be available in the pan page. This balance control is actually set *before* the mono switch in the signal path, within the input section of the channel. Hence it is possible to use the input balance function to correct the levels of two channels feeding a stereo input channel, and then add them together to become a mono sum. A practical example is the feed of a stereo channel from a VTR, one channel containing ambient signals and the other one being the commentator. In this case the 2-channel mode is set to 'mono', and the input balance function is used to correct the mix between ambient and speech signals.

Input Parameters for 5.1 (Surround) Channels

Compared with mono or stereo channels, the global input control section of a surround input channel is slightly different: There is no phase control switch, and the **2 CH Mode** selector has been replaced by **5.1 ORDER**.



DIG 1 GAIN As it is the case with mono or stereo channels, the digital gain stage acts as a trim after the A/D converter. Input gain can be set in 1 dB steps in a range of ± 24 dB. The default value is 0 dB. In a 5.1 channel, all six surround input legs are treated simultaneously.

5.1 ORDER Like the **2 CH MODE** function in a stereo channel, this functionality provides a kind of patching within the 5.1 channel. The bus order in Vista consoles with SW V4.0 has been changed according to the ITU standard (L, R, C, LFE, Ls, Rs). The **5.1 ORDER** selector allows converting different surround formats to the ITU order.

Format	Input Channels	ITU Output Channels
ITU	L R C LFE Ls Rs	L R C LFE Ls Rs
Studer (SW before V4.0)	L R C Ls Rs LFE	
Film	L C R Ls Rs LFE	
L R	L R	

3.3.2 Pre-Amp Remote Parameters

Press **GLOBAL VIEW: A / D CTRL**.

Various analog functions of the mic/line input cards can be remote controlled. On the 5.1 surround input channels these controls are linked for all six legs of the surround signal. All mic/line cards provide an active split output for each microphone channel.



MIC GAIN Gain setting in steps of 1 dB, within a -26 through $+60$ dB range. The display indicates the gain applied to signals passing through the microphone pre-amplifier card. (indication value depending on the current 0dBFS Reference setting).

HPF On/Off Analog low-cut filter for the microphone-level input, with a fixed cutoff frequency of 75 Hz and a slope of 12 dB/octave is available.

SOFT CLIP ON/OFF A soft clip function is available on all channels and can be activated individually. This ‘analog limiter’ may prevent nasty clipping noises in case the audio level should be too high. We recommend activating this function during live productions, since audio is not influenced below about -6 dB_{FS} .

48 V On/Off Toggles phantom power on/off for the microphone input.

A INSERT On/Off *(Not supported by transformer-balanced microphone pre-amplifier cards A949.0447, as well as 16 channel HQ mic/line input modules).* An analog insert point is made available by inserting an optional analog insert card. Its send output is always active at line level, and the return path may be activated by the corresponding switch on the console.

MIC CTRL Free/Other/Owned Toggle switch for remote control of the analog mic/line input parameters. In case of I/O sharing operation this switch is also used for the mic takeover procedure (refer to [chapter 8.3](#)).

3.3.3 Direct, Multi-Track and N-1 Output Parameters

Press **GLOBAL VIEW: OUT n-1**.

This view allows controlling the level of the Direct, Multi-Track and the channel's contribution ('send') to the N-1 bus(es). If the channel is assigned as a bus owner of an N-1 bus, the N-1 bus outputs is controlled from here as well.

From surround input channels, N-1 mono busses are fed with an ITU-compatible mono down-mix of the surround signal. N-1 stereo busses are fed accordingly with an ITU-compatible stereo down-mix.



DIR OUT On/Off	Direct output on/off.
DIR OUT Rotary	Direct output level, MUTE (i.e. $-\infty$ dB) to +10 dB.
Mtrk	Multi-track output level, MUTE (i.e. $-\infty$ dB) to +10 dB.
Pan On/Off	Allows panning of the channel's output signal to the multi-track bus if set to 'Pan On', in addition to the standard channel pan. The panning is adjusted with the usual Pan controls.
n-1 OUT On/Off	N-1 Output on/off.
n-1 OUT Rotary	N-1 Output level, MUTE (i.e. $-\infty$ dB) to +10 dB.
n-1 SEND Rotary	Send level ('contribution') of this channel to all assigned N-1 busses (default: 0 dB).

3.3.4 Mono AUX Parameters

Press one of the **GLOBAL VIEW: AUX MONO** keys.

The mono AUX view provides selection of the AUX bus (ON/OFF), send level adjustment, and pre-/after-fader switching. From 5.1 surround channels, mono AUX sends are fed with an ITU-compatible mono down-mix. From stereo channels, mono AUX sends are also fed with a mono mix - but there is an additional PAN control on each mono AUX send on stereo channels, which allows the user also to send only the left stereo leg to the mono AUX or only the right stereo leg, or everything in between the two extreme settings. The PAN control can be viewed by pressing the **GLOBAL VIEW: AUX MONO** key a second time (on Vista 1).



- AUX m x On/Off** Mono AUX bus selection. Other mono AUX bus views can be selected as well, if provided by the currently loaded configuration (5...8, 9...12, etc.).
- AUX m x Rotary** The send levels for mono AUX 1 through the maximum number configured can be adjusted using this rotary encoder; adjustment range is from Mute ($-\infty$) through +10 dB.
- AUX m x Pre/Post** When the **PRE / POST** key in the fader bay's **GLOBAL VIEW** area is active, the Vistonics view changes as shown above at the right. The signal sent to the mono AUX bus can be selected **PRE** (pre-fader, i.e. *before* the fader) or **POST** (post-fader, i.e. *after* the fader).

3.3.5 Stereo AUX Parameters

Press one of the **GLOBAL VIEW: AUX STEREO** keys.

The stereo AUX view provides selection of the AUX bus (ON/OFF), send level adjustment, pre-/after-fader switching, and pan setting. From 5.1 surround channels, stereo AUX sends are fed with an ITU-compatible stereo down-mix.



Aux s x On/Off Stereo AUX bus selection. Other stereo AUX bus views can be selected as well, if provided by the currently loaded configuration (5...8, 9...12, etc.).

Aux s x Rotary The send levels for stereo AUX busses can be adjusted using this rotary encoder; adjustment range is from MUTE (i.e. $-\infty$) through +10 dB.

AUX s x Pre/Post When the **PRE / POST** key in the fader bay's **GLOBAL VIEW** area is active, the Vistonics view changes similar to the one shown above in the center. The signal sent to the stereo AUX bus can be selected from **PRE** (pre-fader, i.e. *before* the fader) or **POST** (post-fader, i.e. *after* the fader).

AUX s x Pan Rotary The Stereo Aux Pan view is activated by pressing the **PAN** key below the **GLOBAL VIEW - AUX** keys. By default, the Aux panner is linked to the channel pan value (Follow On), as shown above at the right. If the channel panning is 'multi-format', only the L/R setting is used for the Aux pan.

AUX s x Follow On/Off If individual Aux pan settings are required, the default setting ('Follow On', i.e. the Aux pan setting follows the channel pan) may be switched off; the Aux panner is then adjusted with the Vistonics rotary encoder.

3.3.6 Filter Parameters

Press **GLOBAL VIEW: FILTER**.

This view enables the user to control the parameters of the hi- and low-cut filters. These filters are available on the channel-related EQ view as well, refer to [chapter 3.4.1](#). In that chapter you will also find the parameter details. The two filter sections are activated with the **HI CUT** and **LO CUT** hardware keys above the Vistonics section.

For 5.1 surround channels, the high- and low-cut filter parameters applied here are valid for all surround signal legs, *except the LFE*. For further information on this subject, please refer to [chapter 3.4.1](#).



HI CUT/LO CUT x dB	Slope setting for the high- and low-cut filters, selectable from 12, 18, and 24 dB/octave (key toggles 12, 18, 24, 12...).
HI CUT/LO CUT Rotary	Cutoff frequency adjustment for both the high- and low-cut filters: 20 Hz through 20 kHz, in 120 steps.

3.3.7 Delay and Insert Parameters

Press **GLOBAL VIEW: DLY-INS**.

This view enables the user to control the delay and insert parameters.

Please note: The two sections are activated with the **DELAY** and **INS** hardware keys above the Vistonics section.

For 5.1 channels the delay processing block has a maximum delay time of 700 ms (as opposed to the standard 240 or 100 ms delay in the mono or stereo channels).

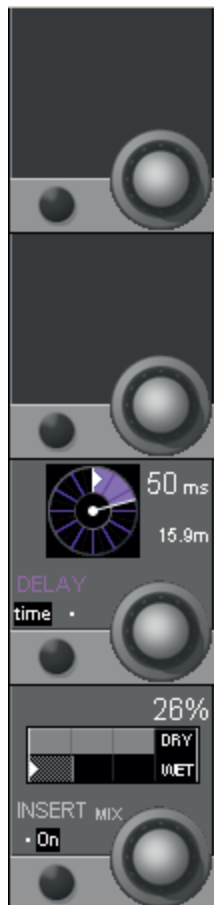

Delay Parameters:

The delay value is set using the rotary encoder. It is displayed as a *physical distance* (meters) and as a *delay time* (either samples or milli-seconds).

DELAY On/Off is selected with the **DELAY** hardware key above the Vistonics section.

DELAY Rotary Delay time can be set in a range from 0 through 100 ms (or, depending on the currently loaded configuration, to a maximum of 240 ms). The value is displayed as a delay distance as well (from 0 cm up to 81.5 m, depending on the configuration).

DELAY time/smpl Selects the delay setting in samples ('smpl' – fine setting) or milli-seconds ('time' – coarse setting).

Insert Parameters:

The insert section provides selection and control of the insert point (INSERT ON/OFF) and the INSERT MIX function (ON/OFF), plus defining the dry/wet mix ratio (INSERT MIX %).

INSERT On/Off is selected with the **INSERT** hardware key above the Viconics section. 'On' activates the insert return signal; 'off' selects the Input Signal (that corresponds to the insert send signal).

INSERT MIX On/Off On activates the insert mix function; Off selects only the insert return signal. When the insert mix function is set to On, the ratio of the dry (send) to the wet (return) signal depends on the selected mix ratio. In other words, mixing between the insert send and the insert return signals is possible.

INSERT MIX Rotary If the MIX function is On, this parameter allows mixing or blending of the dry (send) and the wet (return) signals. 0% setting: dry signal only; 100% setting: wet signal only.

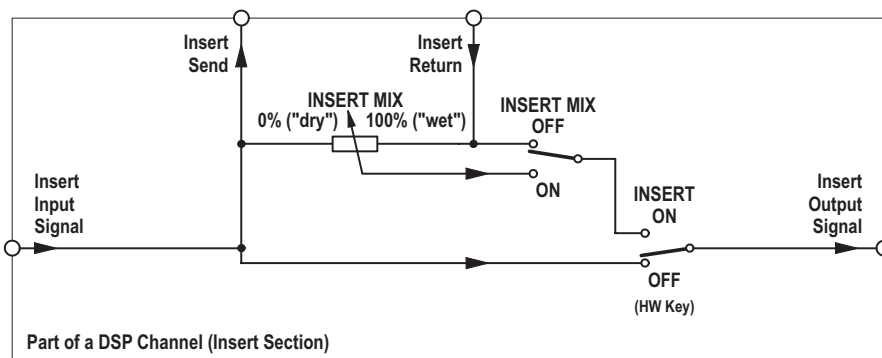

Note *If the insert is routed to an external, non-digital device (such as an analog compressor patched through D/A and A/D converters), the delay introduced by the D/A-A/D conversion will result in a comb-filter effect if the insert return and mix are active and the MIX % is set anywhere between DRY and WET. When inserting external, analog devices, the MIX% should always be set to WET (i.e., to 100%), unless this comb-filter effect is desired - or the delay is compensated by adding delay on other signal paths. The latter is made very easy by using a gang and adding delay to multiple console channels.*

3.3.8 Dynamics Parameters

Standard or Vintage Dynamics?

Since SW version 4.0 there is an alternative dynamics processing block available for *mono and stereo channels*. It is called ‘Vintage Dynamics’ and consists of a compressor that can be used together with an expander/noise-gate. The design focus was very clearly set on the compressor.

This compressor algorithm provides an alternative to the current dynamics section in the Vista consoles, which has been described as rather ‘transparent’. For some applications, however, a compressor can be utilized in a more pronounced way, i.e., as an effect itself. For this purpose the ‘vintage dynamics’ was created. It is targeted to be flexible enough for different types of sound coloration including extreme and unusual settings, but does not feature a dedicated limiter.

Selection of standard or vintage dynamics depends on the currently loaded configuration.

Vintage Dynamics Block Diagram:

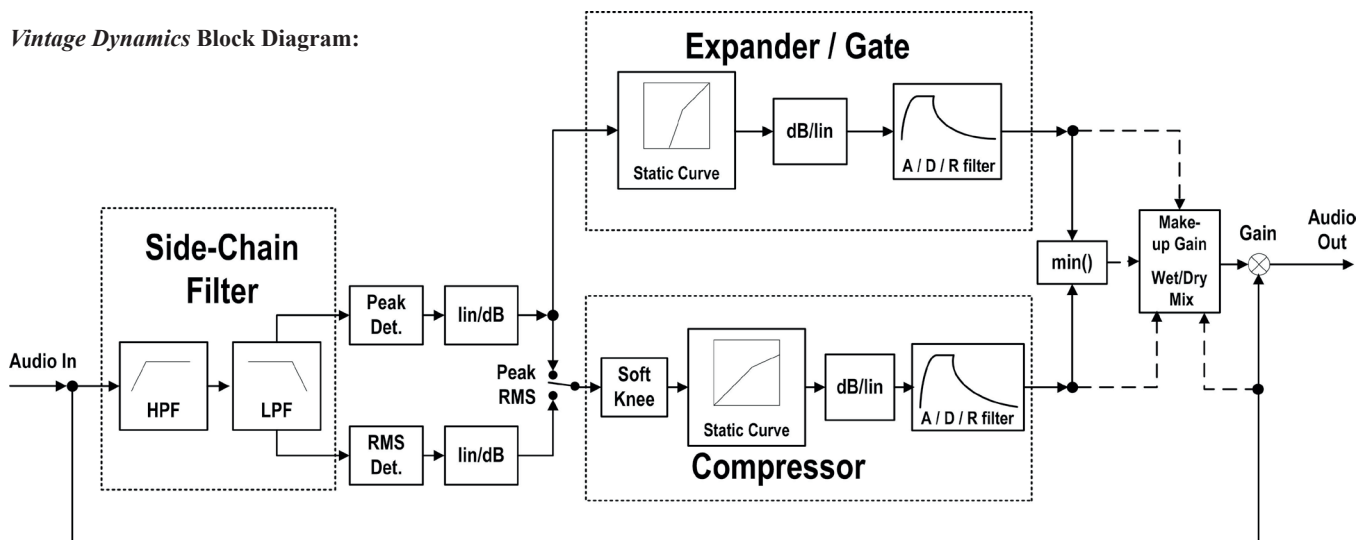

The *standard* dynamics section features a limiter, while the *vintage* dynamics section only has compressor parameters – knowing this might be helpful when sitting at the console and having to discriminate the dynamics sections. In the illustration on the next page, the left-hand channel shows the standard dynamics section parameters, the right-hand channel the ones of a vintage dynamics section.

3.3.8.1 Compressor / Limiter Parameters

Press **GLOBAL VIEW: COMP LIMIT**.

This view enables the user to control the *most important* parameters of the dynamics section’s compressor and limiter parts. The *complete* parameter set is available on the channel-related dynamics view, refer to [chapter 3.4.3](#). There you will also find all parameter details.

For 5.1 surround channels, the compressor and limiter settings are valid for all surround signal legs *except the LFE*. For further information on this subject, please refer to [chapter 3.4.3.2](#).

The compressor and limiter parts of the dynamics section can *simultaneously* be activated with the **COMP LIMIT** hardware key above the Vistonics section, in addition to the individual on/off keys described below.

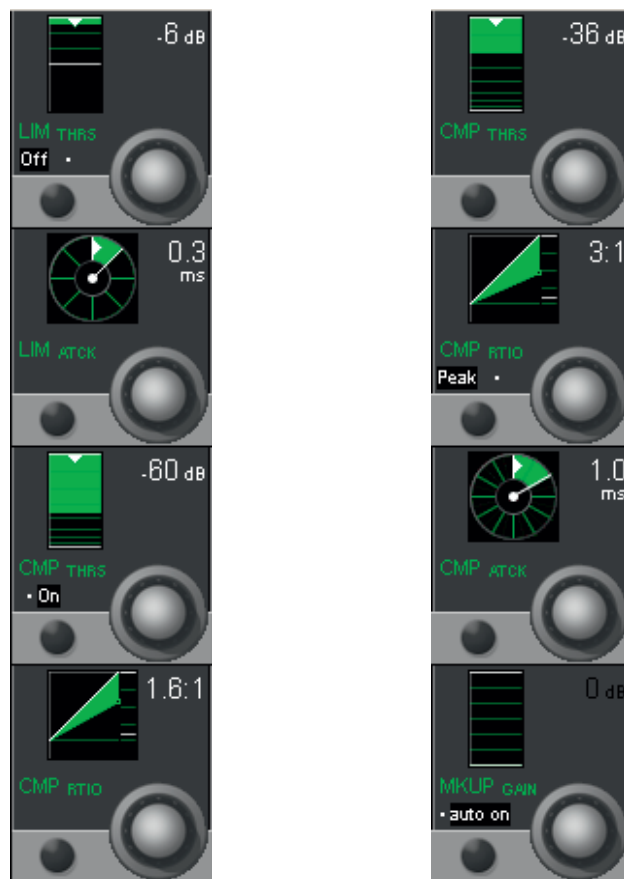

Standard Dynamics Section (left):

- LIM THRS** Rotary The limiter threshold can be adjusted in 1 dB steps from 0 dB_{FS} to -48 dB_{FS}. The limiter threshold corresponds to the output level.
- LIM On/Off** Individual limiter on/off control.
- LIM ATCK** Rotary The limiter attack time can be adjusted in 9 steps within a 200 μs to 1 ms range.
- CMP THRS** Rotary The compressor threshold level can be adjusted in 1 dB steps from 0 dB_{FS} to -96 dB_{FS}.
- CMP On/Off** Individual compressor on/off control.
- CMP RTIO** Rotary The compressor ratio can be adjusted from 1:1 (no compression) to 20:1 (heavy compression).

Vintage Dynamics Section (right):

- CMP THRS** Rotary The compressor threshold level can be adjusted in 1 dB steps from 0 dB_{FS} to -96 dB_{FS}.
- CMP RTIO** Rotary The compressor ratio can be adjusted from 1:1 (no compression) to 40:1 (extra heavy compression).
- CMP peak/RMS** Level detection mode: peak or RMS
- CMP ATCK** The compressor attack time can be adjusted in 64 steps within a range of 0.2 ms to 250 ms.
- MKUP GAIN auto on/off** 'auto on' automatically compensates a level loss caused by the dynamics processing. 'auto off' activates the manual MKUP GAIN rotary control.
- MKUP GAIN** Rotary To manually compensate a level loss caused by the dynamics processing, adjustable in 1 dB steps from 0 through +24 dB.

3.3.8.2 Expander / Gate Parameters

Press **GLOBAL VIEW: EXP GATE**.

This view enables the user to control the *most important* parameters of the dynamics section's expander and gate parts. The *complete* parameter set is available on the channel-related dynamics view, refer to [chapter 3.4.3](#). There you will also find all the parameter details.

For 5.1 surround channels, the expander and gate settings are valid for all surround signal legs *except the LFE*. For further information on this subject, please refer to [chapter 3.4.3.2](#).

Note The expander and gate parts of the dynamics section can be activated *simultaneously* with the **EXP GATE** hardware key above the Vistonics section, in addition to the *individual* on/off keys described below.

Standard Dynamics Section



EXP THRS Rotary The expander threshold level can be adjusted in 1 dB steps from 0 dB_{FS} to -96 dB_{FS}.

EXP On/Off Expander on/off.

EXP RTIO Rotary The expander ratio can be adjusted from 1:1 (no expansion) to 20:1 (heavy expansion).

GATE THRS Rotary The gate threshold level can be adjusted in 1 dB steps from 0 dB_{FS} to -96 dB_{FS}.

GATE On/Off Gate on/off.

GATE ATCK Rotary The gate attack time can be adjusted in 9 steps within a 200 μs to 1 ms range.

GATE hyst on/off The gate hysteresis function provides an offset between the un-mute and mute thresholds. So the gate will remain open (un-muted) at a level slightly lower than the one required to open it in order to avoid effects such as chattering.

Vintage Dynamics Section

There are two different views for the vintage expander/gate view; one of them (below left) is displayed when pressing the **EXP GATE** hardware key, and the other one (below right) when pressing \hat{u} (Shift) before the **EXP GATE** key.

Standard View:

'Shift' View:

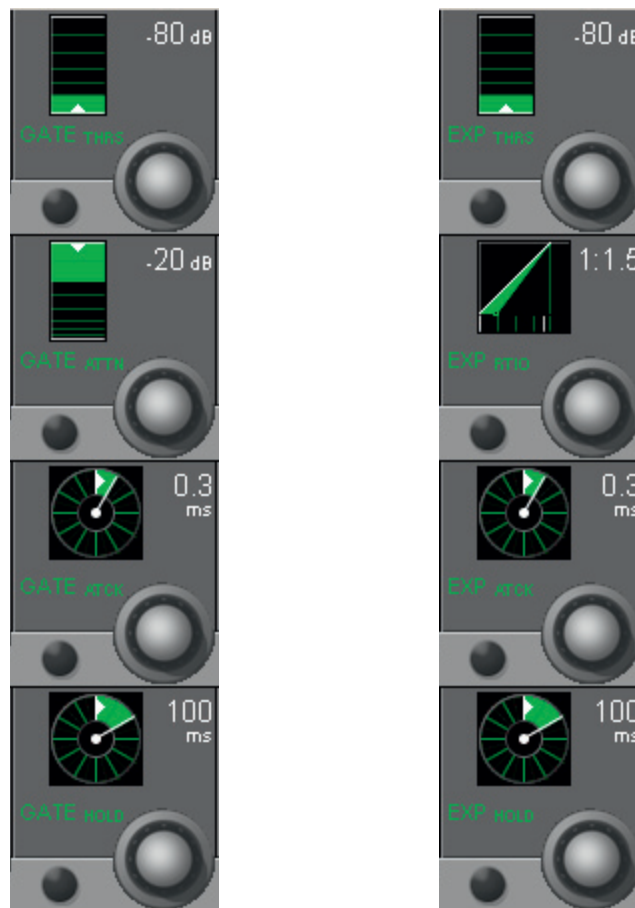

Standard View

- GATE THRS** Rotary The gate threshold level can be adjusted in 1 dB steps from 0 dB_{FS} to -96 dB_{FS}.
- GATE ATTN** Rotary The gate attenuation level can be adjusted in 1 dB steps from 0 dB_{FS} to +60 dB_{FS}.
- GATE ATCK** Rotary The gate attack time can be adjusted in 64 steps within a range of 0.2 ms to 5 ms.
- GATE HOLD** Rotary The gate hold time can be adjusted in 64 steps from 0 ms to 2000 ms.

'Shift' View

- EXP THRS** Rotary The expander threshold level can be adjusted in 1 dB steps from 0 dB_{FS} to -96 dB_{FS}.
- EXP RATIO** Rotary The expander ratio level can be adjusted from 1:1 (no expansion) to 1:40 (heavy expansion).
- EXP ATCK** Rotary The expander attack time can be adjusted in 64 steps within a range of 0.2 ms to 5 ms.
- EXP HOLD** Rotary The expander hold time can be adjusted in 64 steps from 0 ms to 2000 ms .

3.3.9 Parametric EQ Parameters



Select a bay showing channels that have the parametric EQ configured. Press **GLOBAL VIEW: EQ**.

If a channel has configured both the parametric and graphic EQs, its Vistonics icon indicates additional **PAR** and **GEQ** labels; its touch surface is split into a left (**PAR**) and a right (**GEQ**) part, as shown at the left. Upon pressing **GLOBAL VIEW: EQ**, the parametric EQ parameters are shown on the Vistonics screen. This view enables the user to control the *most important parameters* of the EQ section. The *complete* parameter set is available on the channel-related EQ view, refer to [chapter 3.4.1](#). There you will also find all parameter details. For 5.1 surround channels the equalizer settings are valid for all surround signal legs *except the LFE*. For further information on this subject, please refer to [chapter 3.4.1](#).

All four bands of the EQ section can be activated *simultaneously* with the **EQ** hardware key above the Vistonics section, in addition to the *individual* on/off keys described below.

There are two options for the EQ view; one of them (below left) is displayed when pressing the **EQ** hardware key only, and the other one (below right) when pressing \hat{u} (Shift) followed by **EQ**.

Standard View:



'Shift' View:



HI / HM / LM / LO On/Off

On/off function for the selected EQ band.

HI / HM / LM / LO GAIN Rotary

Boost/cut adjustment; ± 18 dB in steps of 0.5 dB.

HM / LM FREQ Rotary

Center frequency adjustment for the high-mid and low-mid bands. For both bands, the center frequency can be adjusted from 20 Hz through 20 kHz, in 120 steps. *These controls are visible in the 'shift' view only.*

3.3.10 Graphic EQ Parameters

There is *no global view* of the graphic EQ available, since the graphic EQ of one channel always uses up the complete Vistonics screen. For graphic EQ operation please refer to [chapter 3.4.2](#).

3.3.11 Panning Parameters

Press **GLOBAL VIEW: PAN**.

This view enables the user to control the *most important* parameters of the panning section. Representation is different depending on channel type (mono/stereo/5.1/stereo upmix), and on the selected panning format. The *complete* parameter set is available on the channel-related pan view, refer to [chapter 3.4.4](#). There you will also find all parameter details.

The panning section can be activated with the **PAN** hardware key above the Vistonics section, in addition to the different, individual on/off keys.

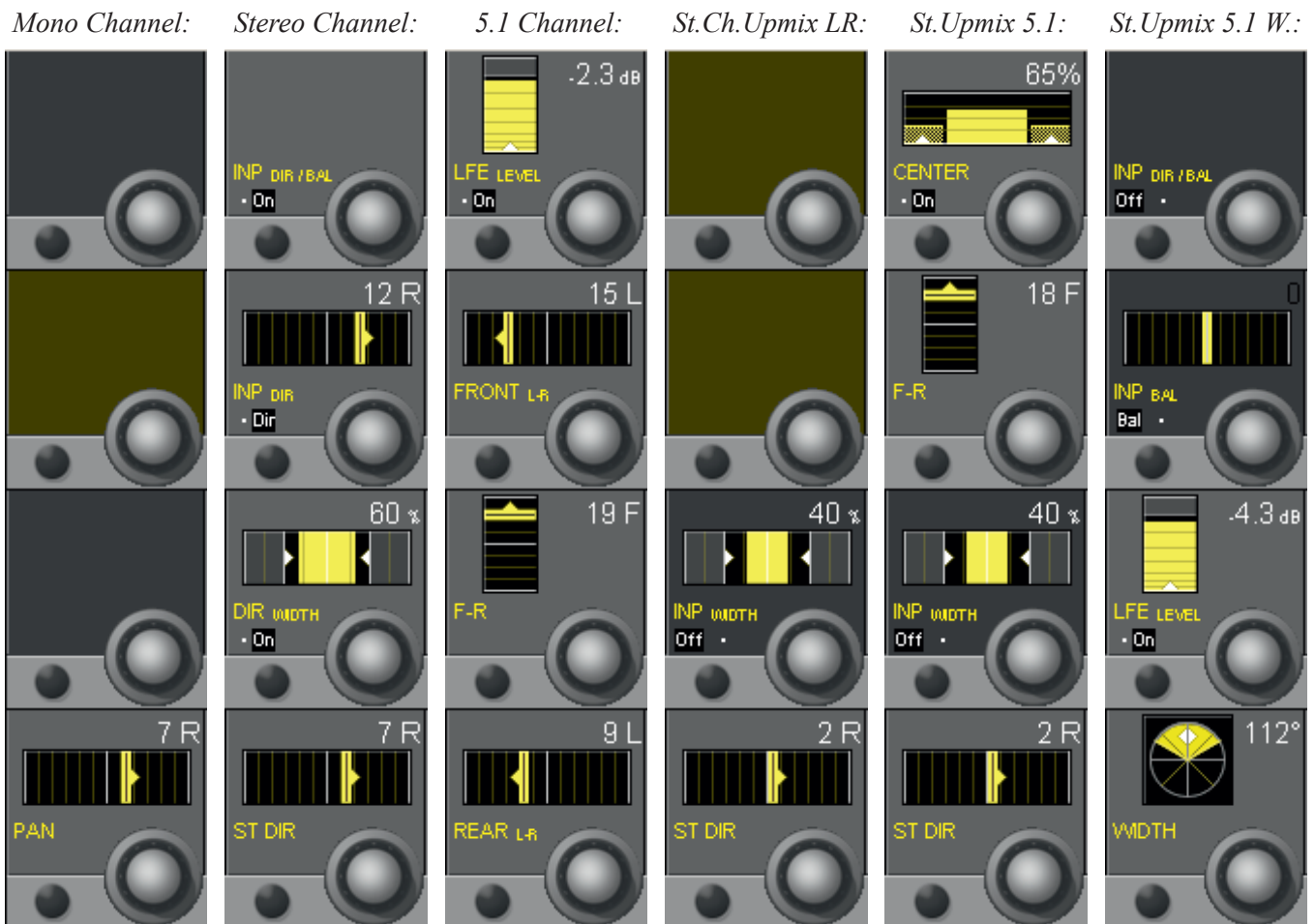

The DIR WIDTH display on stereo channels only appears if this feature has been configured for the corresponding channel.

If a channel is configured with the 'Input Dir/Bal' function, this view also displays the input balance function placed within the input section of the channel.

3.3.12 Global View of 5.1 Surround Input Channels



With the 5.1 surround input channels, the user has input, EQ, dynamics and panning sections completely designed for premixed 5.1-channel input sources. The main goal is that he can adjust the most important parameters directly with a touch on the Vistonics screen, without the need to 'spilling' single mono or stereo channels to additional faders, while other important sources would be hidden and become unavailable. A global view of a 5.1 input channel is shown on the left.

3.3.13 Global Bus Assignment View

Press **GLOBAL VIEW: BUS ASN** (at the left-hand side of the fader bay). This is an On/Off key that can be activated *in addition* to other global view keys. The bus assignment overview will cover the EQ, dynamics and pan curves on the lower part of the TFT; it disappears when **GLOBAL VIEW: BUS ASN** is pressed again.

The displayed bus assignment bitmap varies depending on the channel type. On a master channel, for instance, no display is activated, since a master channel cannot be routed to a bus. Other channel types may show a part of the bitmap only, depending on possible bus assignments. Therefore the display may show a blank region for some channel types.

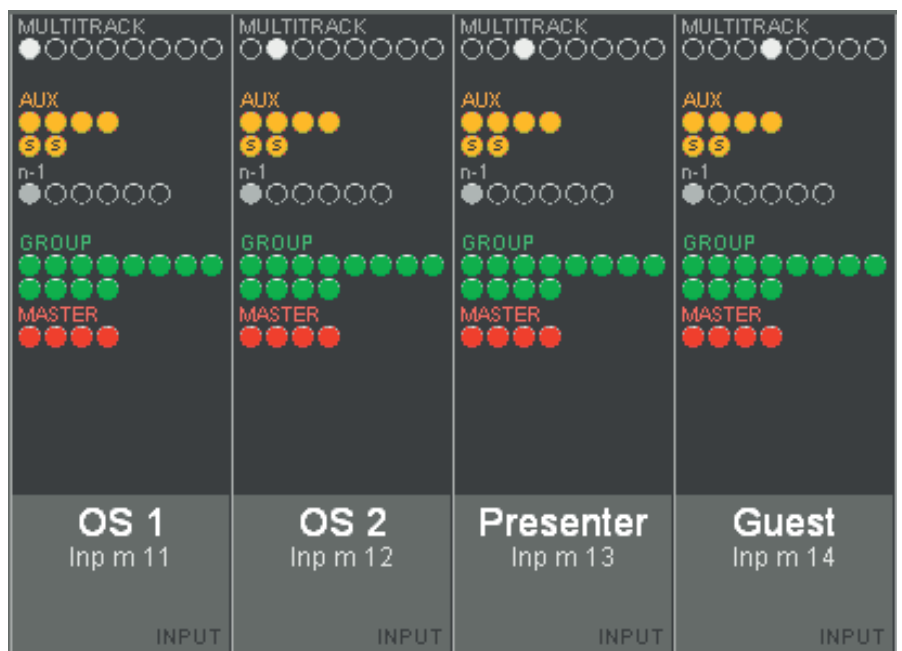

3.3.14 Generic and Label Display Area

Channel label display: The top line always indicates the inherited label (corresponds to the device label of the patched source) of each channel. The second line normally is set to device label display, but can be changed by pressing **GLOBAL VIEW: LABEL TYPE**.

The channel *type* is indicated with colors in the label display; in addition, the bottom right corner of the label field shows the channel type in writing, as shown below.

CGM 1	CGM 2	CGM 3	Aux m 1	Aux m 2	Aux s 1	Mst s 1
CGM	CGM	CGM	AUX	AUX	AUX S	MAST S

Generic Displays, such as n-1, OVER (fader over-range), etc. are only shown as long as they are active:



The numerical fader value is displayed in dB whenever the fader knob is touched; it disappears a short while after the fader knob has been released.



The graphical display of snapshot preview value and current fader value pops up over the right-hand part of the display area, showing the values as bar graphs (current value in gray, snapshot preview value in pink).

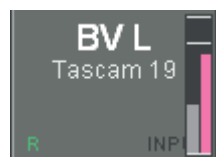

Channels that feed a VistaMix (VMX) bus will show one (mono VMX) or two (stereo VMX) miniature fader symbols in the label area of the Vistonics display that show the gain of the Vistamix function dynamically. Please note that these are *not* audio level meters.



3.4 Channel-Related Views

3.4.1 Parametric EQ and Filter Parameters

Note Since SW V4.7 there is an additional 30-band graphic EQ available; both graphic and parametric EQs can be set up either for all or specific channels using the Vista Configuration Editor.

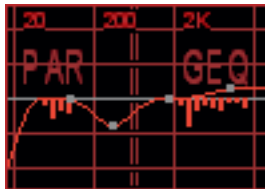

If both EQs are configured within one single channel, the display is split into two different touch areas, showing the combined response of both EQs. It allows unfolding *either* the graphic *or* the parametric EQ parameters of this channel on the Vistonics screen for adjustment. For details of the graphic EQ please refer to the [next chapter](#).

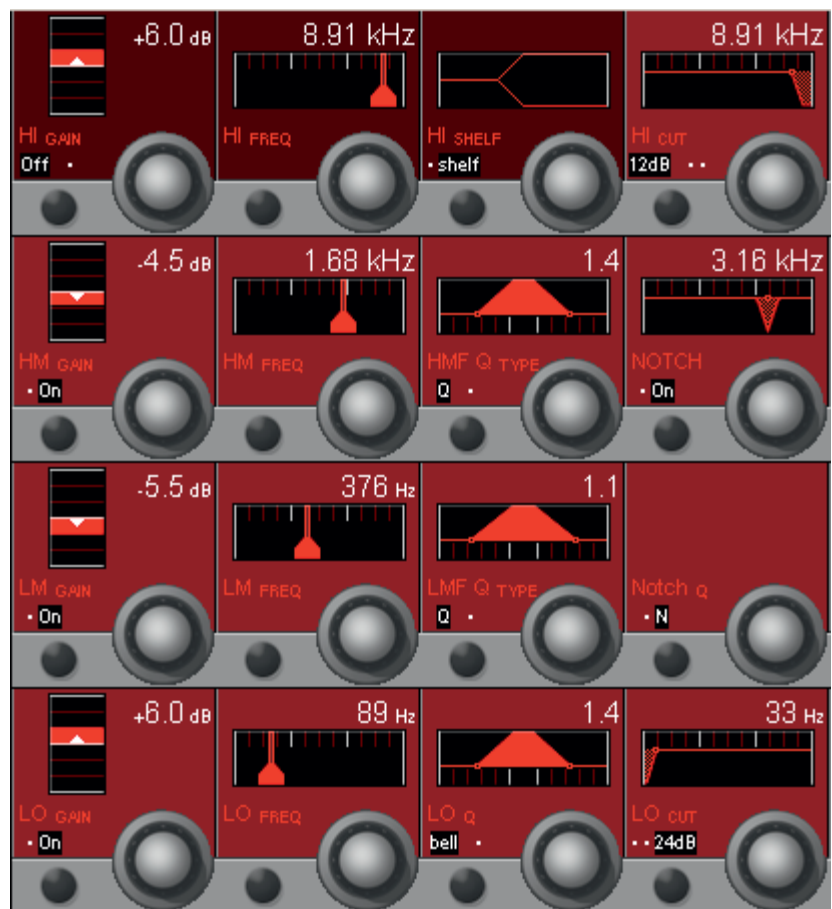

EQ Parameters:

HI / HM / LM / LO On/Off	On/off function for the selected (high, high-mid, low-mid, low) EQ band.
HI / HM / LM / LO GAIN Rotary	Boost/cut adjustment; ± 18 dB in steps of 0.5 dB.
HI / HM / LM / LO FREQ Rotary	Center frequency (or, if 'shelf' is selected for the HI or LO frequency band: turnover frequency) adjustment. For all four bands, the center/turnover frequency can be adjusted from 20 Hz through 20 kHz, in 120 steps.
Q/R or bell/shelf	For the HM and LM bands, the Q type can be selected from <i>Q</i> (constant-Q) and <i>R</i> (constant-range) filter types. For the HI and LO bands, <i>bell</i> (same as 'constant-Q' for HM/LM bands) or <i>shelf</i> (shelving-type filter) can be selected.

Q value Rotary The Q (bandwidth) can be set to values from 0.27 through 8.7, in 30 steps. For the HM and LM bands Q can be set only if 'bell' is selected.
HM, high-mid frequency, and LM, low-mid frequency: Q = 0.27 through 8.7, in 30 steps.

High-Cut/Low-Cut Filter Parameters:

HI CUT/LO CUT x dB Slope setting for the high- and low-cut filters, selectable from 12, 18, and 24 dB/octave (key toggles 12, 18, 24, 12...).

HI CUT/LO CUT Rotary Cutoff frequency adjustment for the high- and low-cut filter: 20 Hz through 20 kHz, in 120 steps.

Notch Filter Parameters:

Please note that these two fields only appear if the notch filter is contained in the currently loaded configuration.

NOTCH On/Off On/off function for the notch filter.

NOTCH Rotary Center frequency for the notch filter: 20 Hz through 20 kHz, in 120 steps.

Notch Q The notch filter's Q is selectable from two fixed values; W (wide, Q=2), and N (narrow, Q=10).

Note The **EQ**, **HI CUT** and **LO CUT** hardware keys in the **CHANNEL PROCESSING** area can be used for activating or deactivating the complete EQ, high- and low-cut filter sections of a channel (or a gang of channels) selected with **LINK/SEL**, in addition to the *individual* on/off keys described above.

5.1 Surround Channels

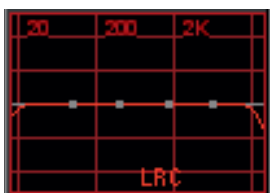

This view is the same as with mono or stereo channels. Please note that the equalizer settings applied here will be valid for all surround signal legs *except the LFE*.

If an EQ setting has been made on a 5.1 surround channel, the normal Vistonics EQ display shows in small characters which signal legs are different from the others (e.g. 'Lf'), as shown left.

If one or more of the signal legs must be adjusted differently from others – such as boosting HF in the center channel only, the **CHANNEL VIEW** has to be selected. Then all the separate EQ settings for 'Front', 'Center', 'LFE' and 'Rear' are accessible.

3.4.2 Graphic EQ Parameters

Note Since SW V4.7 there is an additional 30-band graphic EQ available; both graphic and parametric EQs can be set up either for all or specific channels using the Vista Configuration Editor.

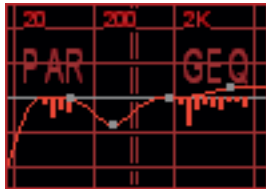

If both EQs are configured within one single channel, the display is split into two different touch areas, showing the combined response of both EQs. It allows unfolding *either* the graphic *or* the parametric EQ parameters of this channel on the Vistonics screen for adjustment. For details of the parametric EQ please refer to the [previous chapter](#).

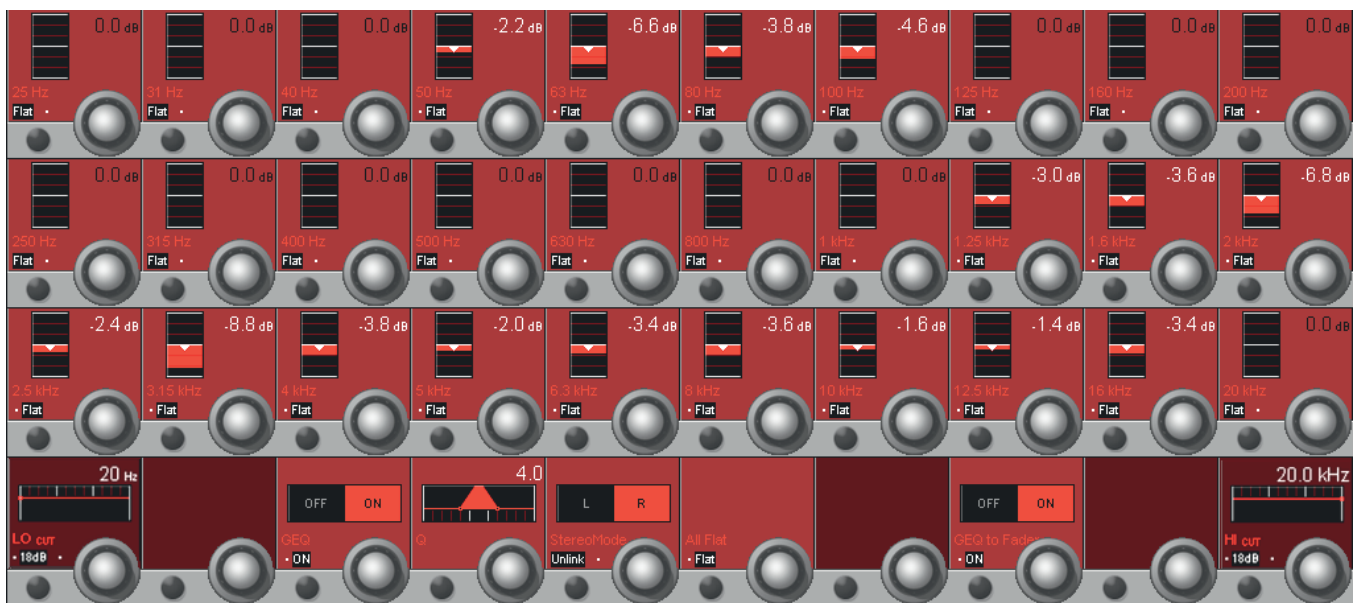

Boost/Cut (Rotary Knobs) The 30 rotary knobs in the three upper rows control boost or cut for the different frequency bands. The individual band center frequencies are fixed and displayed in the corresponding Vistonics fields. Boost/cut can be adjusted in a ± 12 dB range in steps of 0.2 dB.

Flat Every band may individually be set to 'flat', i.e., to 0 dB.

LO/HI CUT The low- and high-cut filters are the same as described in the [previous chapter](#).

GEQ OFF/ON The complete graphic EQ can be switched on or off by pressing this Vistonics key or by turning the rotary encoder. This is as opposed to the **EQ** hardware key in the **CH PROCESSING** section that is used to activate or deactivate the parametric and the graphic EQ at once. Please note that the hardware key overrides the Vistonics key setting.

Q Allows setting the width (Q) of all the EQ bands simultaneously between 4 (wider) and 6 (less wide) in five steps.

StereoMode For stereo channels, the graphic EQ can be linked or unlinked for the left and right channels. If 'Unlink' is selected, individual settings for L and R can be set; selection between L and R is done with the rotary knob. Default setting is 'Link'.

All Flat Sets all bands to 'flat', i.e., to 0 dB.

GEQ to Faders For ease of operation, the graphic EQ may be switched over to 30 of the console faders for both indication and control the setting. On Vista consoles featuring FaderGlow the colour of the corresponding fader tracks will illuminate in red. The label row of the Vistonics icons changes to center frequency indication, and only the Vistonics EQ icon in the channel strip on which the EQ is active is displayed. All others are blanked to clearly show which channel is affected by the graphic EQ. Any bands set to boost or cut will in addition have their **MUTE** key illuminated in red. Individual bands may be set to 'flat' also by pressing their illuminated **MUTE** key.

As soon as any other control except a fader or a channel mute key is touched or operated, fader operation is immediately cancelled and switches back to normal mode.

Note : On Vista consoles with 22 faders GEQ to Faders is not applicable.

3.4.3 Dynamics Parameters

3.4.3.1 Standard Dynamics

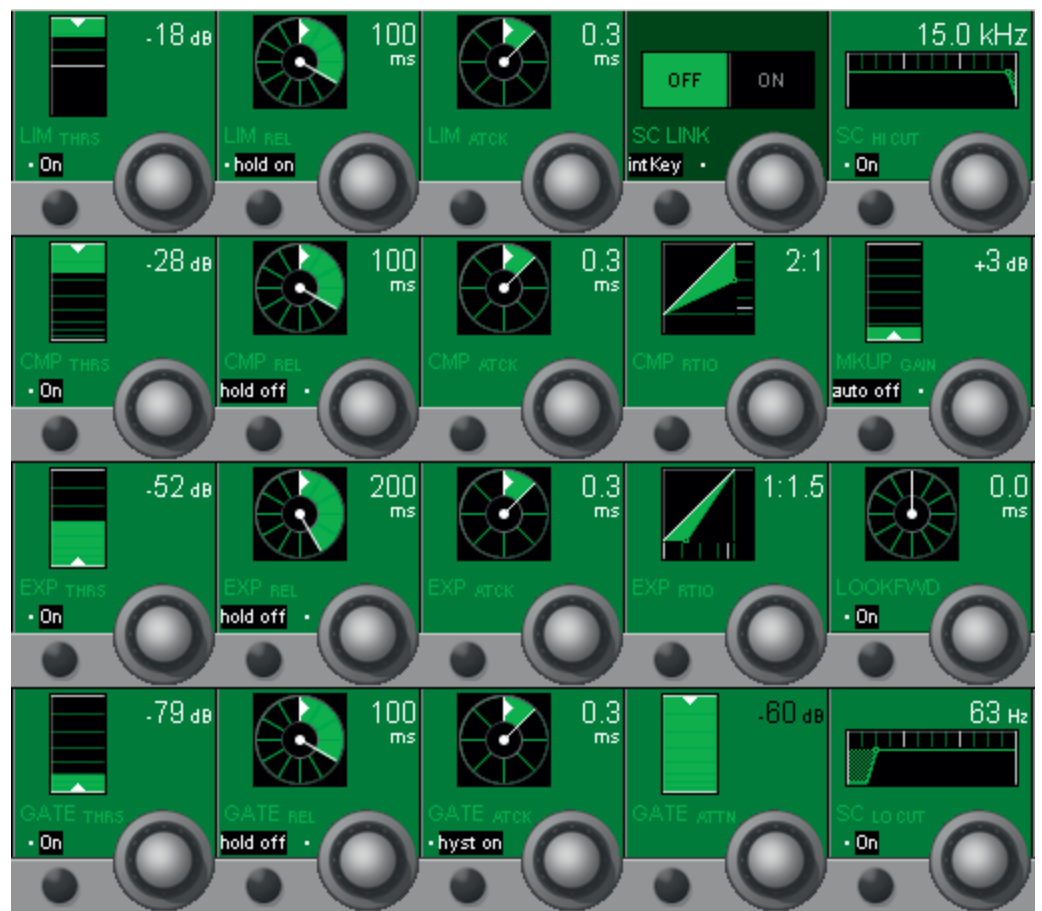

Limiter Parameters:

LIM On/Off Limiter on/off.

LIM THRS Rotary The limiter threshold (= output level) can be adjusted in 1 dB steps from 0 dB_{FS} to -48 dB_{FS}.

LIM REL Rotary The limiter release time can be adjusted in 13 steps within a 10 ms to 10 s range (10 ms, 20 ms, 30 ms, 50 ms, 100 ms, 200 ms, 300 ms, 500 ms, 1 s, 2 s, 3 s, 5 s, and 10 s).

LIM hold on/off Hold on = 150 ms, off = 0 ms.

LIM ATCK Rotary The limiter attack time can be adjusted in 9 steps within a 200 μs to 1 ms range (0.2 ms, 0.3 ms, 0.4 ms, 0.5 ms, 0.6 ms, 0.7 ms, 0.8 ms, 0.9 ms, and 1 ms).

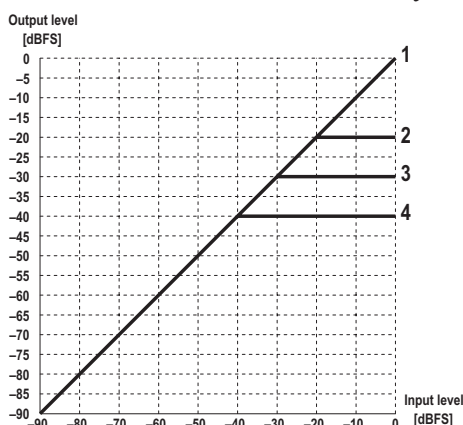

Curve	Limiter	Threshold [dB]
1	OFF	Any
1	ON	0
2	ON	-20
3	ON	-30
4	ON	-40

Compressor Parameters:

CMP On/Off Compressor on/off.

CMP THRS Rotary The compressor threshold level can be adjusted in 1 dB steps from 0 dB_{FS} to -96 dB_{FS}.

CMP REL Rotary The compressor release time can be adjusted in 13 steps within a 10 ms to 10 s range (10 ms, 20 ms, 30 ms, 50 ms, 100 ms, 200 ms, 300 ms, 500 ms, 1 s, 2 s, 3 s, 5 s, and 10 s).

CMP hold on/off Hold on = 150 ms, off = 0 ms.

CMP ATCK Rotary The compressor attack time can be adjusted in 9 steps within a 200 μs to 20 ms range (0.2 ms, 0.3 ms, 0.5 ms, 1 ms, 2 ms, 3 ms, 5 ms, 10 ms, and 20 ms).

CMP RTIO Rotary The compressor ratio can be adjusted from 1:1 (no compression) to 20:1 (heavy compression) in the following steps: 1:1, 5:4, 4:3, 3:2, 5:3, 2:1, 3:1, 5:1, 7:1, 10:1, and 20:1.

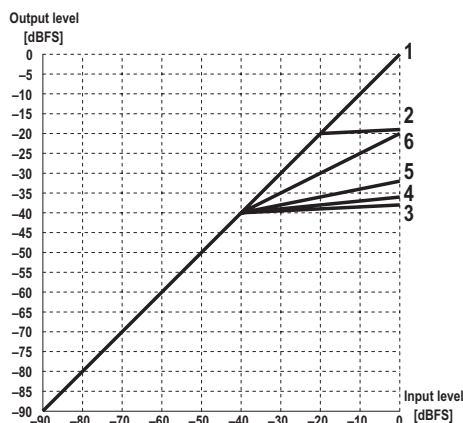

Curve	Compressor	Threshold [dB]	Ratio
1	OFF	any	any
1	ON	0	1:1
2	ON	-20	20:1
3	ON	-40	20:1
4	ON	-40	20:1
5	ON	-40	5:1
6	ON	-40	2:1

Expander Parameters:

EXP On/Off Expander on/off.

EXP THRS Rotary The expander threshold level can be adjusted in 1 dB steps from 0 dB_{FS} to -96 dB_{FS}.

EXP REL Rotary The expander release time can be adjusted in 13 steps within a 10 ms through 10 s range (10 ms, 20 ms, 30 ms, 50 ms, 100 ms, 200 ms, 300 ms, 500 ms, 1 s, 2 s, 3 s, 5 s, and 10 s).

EXP hold on/off Hold on = 150 ms, off = 0 ms.

EXP ATCK Rotary The expander attack time can be adjusted in 9 steps within a 200 μs to 1 ms range (0.2 ms, 0.3 ms, 0.4 ms, 0.5 ms, 0.6 ms, 0.7 ms, 0.8 ms, 0.9 ms, and 1 ms).

EXP RTIO Rotary The expander ratio can be adjusted from 1:1 (no expansion) to 1:20 (heavy expansion) in the following steps: 1:1, 1:1.3, 1:1.4, 1:1.5, 1:1.7, 1:2, 1:3, 1:5, 1:7, 1:10, and 1:20.

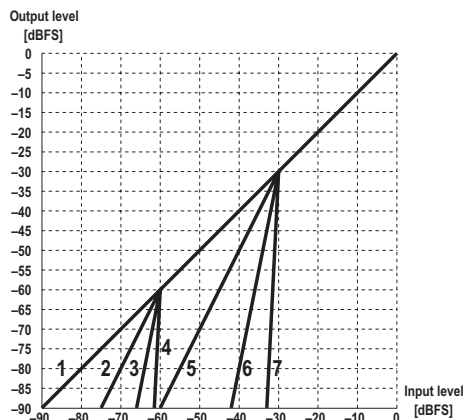

Curve	Expander	Threshold [dB]	Ratio
1	OFF	any	any
1	ON	-96	any
1	ON	-30	1:1
2	ON	-60	1:2
3	ON	-60	1:5
4	ON	-60	1:20
5	ON	-30	1:2
6	ON	-30	1:5
7	ON	-30	1:20

Gate Parameters: GATE On/Off Gate on/off.

GATE THRS Rotary The gate threshold level can be adjusted in 1 dB steps from 0 dB_{FS} to -96 dB_{FS}.

GATE REL Rotary The gate release time can be adjusted in 13 steps within a 10 ms through 10 s range (10 ms, 20 ms, 30 ms, 50 ms, 100 ms, 200 ms, 300 ms, 500 ms, 1 s, 2 s, 3 s, 5 s, and 10 s).

GATE hold on/off Hold on = 150 ms, off = 0 ms.

GATE ATCK Rotary The gate attack time can be adjusted in 9 steps within a 200 μs to 1 ms range (0.2 ms, 0.3 ms, 0.4 ms, 0.5 ms, 0.6 ms, 0.7 ms, 0.8 ms, 0.9 ms, and 1 ms).

GATE hyst on/off The gate hysteresis function provides an offset between the un-mute and mute thresholds. This means the gate will remain open (un-muted) at a lower level than the level than was required to open it. For example, a threshold can be set so that amp noise from an electric guitar will be attenuated as long as the guitar is not played. However, as the guitar sustains and loses energy (level) over time, the gate will remain open at levels below the one that caused it to open in the first place (un-mute threshold). Once the level falls far enough, the gate will close (mute) again.

GATE ATTN Rotary The attenuation level can be adjusted in 1 dB steps from 0 dB_{FS} to -48 dB_{FS}.

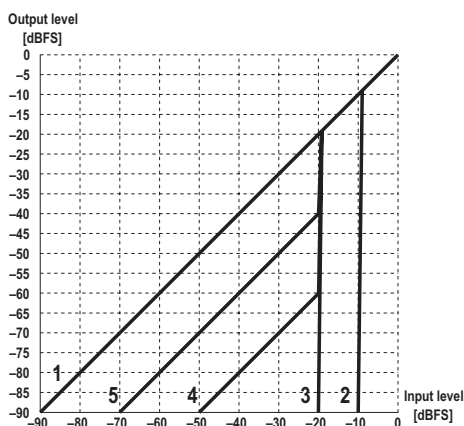

Curve	Gate	Threshold [dB]	Attenuation [dB]
1	OFF	any	any
1	ON	0	0
2	ON	-10	max.
3	ON	-20	max.
4	ON	-20	-40
5	ON	-20	-20

Parameters Shared by all Dynamics Functions:

SC LINK Rotary The Side-Chain Link function allows forming a side-chain group from up to eight channels in order to control the dynamics of all of them by the highest of all side-chain group member levels ('one to control them all'). Side-chains are defined in the GC's Channel Patch window. The rotary encoder switches the side-chain link function on/off, if it is available for the specified channel.

SC LINK intKey/extKey The key source input can be selected from intKey (dynamics processing depends on the channel's input signal), or extKey (processing is controlled by a signal connected via the patch).

SC HI CUT/LO CUT On/Off High- and low-cut filters are available within the side-chain key signal. This facilitates frequency-dependent dynamic processing for creating effects, such as de-essing. Both side-chain filters can be switched on/off independently.

SC HI CUT/LO CUT Rotary	Both side-chain high- and low-cut filters feature cut-off frequencies continuously adjustable between 20 Hz and 20 kHz.
MKUP GAIN auto on/off	‘auto on’ automatically compensates a compressor level loss. ‘auto off’ activates the manual MKUP GAIN rotary control.
MKUP GAIN Rotary	To manually compensate a level loss caused by the dynamics processing, adjustable in 1 dB steps from 0 through +24 dB.
LOOKFWD On/Off	The Look-Forward Delay function allows inserting an audio delay after the dynamics level detector in order to work with higher attack times without any overshooting of levels.
LOOKFWD Rotary	The Look-Forward Delay can be set in 11 steps within a range from 0 to 25 ms (0 ms, 0.2 ms, 0.3 ms, 0.5 ms, 1 ms, 2 ms, 3 ms, 5 ms, 10 ms, 20 ms, and 25 ms). By activating the look-forward feature, a real delay is inserted into the audio path. In order to avoid artifacts with other console channels, it is recommended to insert a corresponding delay into the other channels as well.

Note The **COMP/LIMIT** and **EXP/GATE** hardware keys in the **CHANNEL PROCESSING** area can be used for activating/deactivating the compressor *and* limiter, and the expander *and* gate parts of the dynamics section of a channel (or a gang of channels) selected with **LINK/SEL**, in addition to the individual on/off keys for each dynamics function.

3.4.3.2 Standard Dynamics for 5.1 Surround Channels

Touch the green Vistonics dynamics field.

This view is the same as with mono or stereo channels with one exception, refer to the screenshot below. *Please note that the dynamics settings applied here will be valid for all surround signal legs except the LFE.*

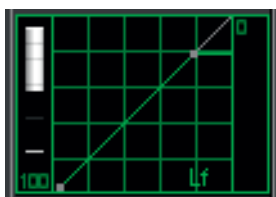
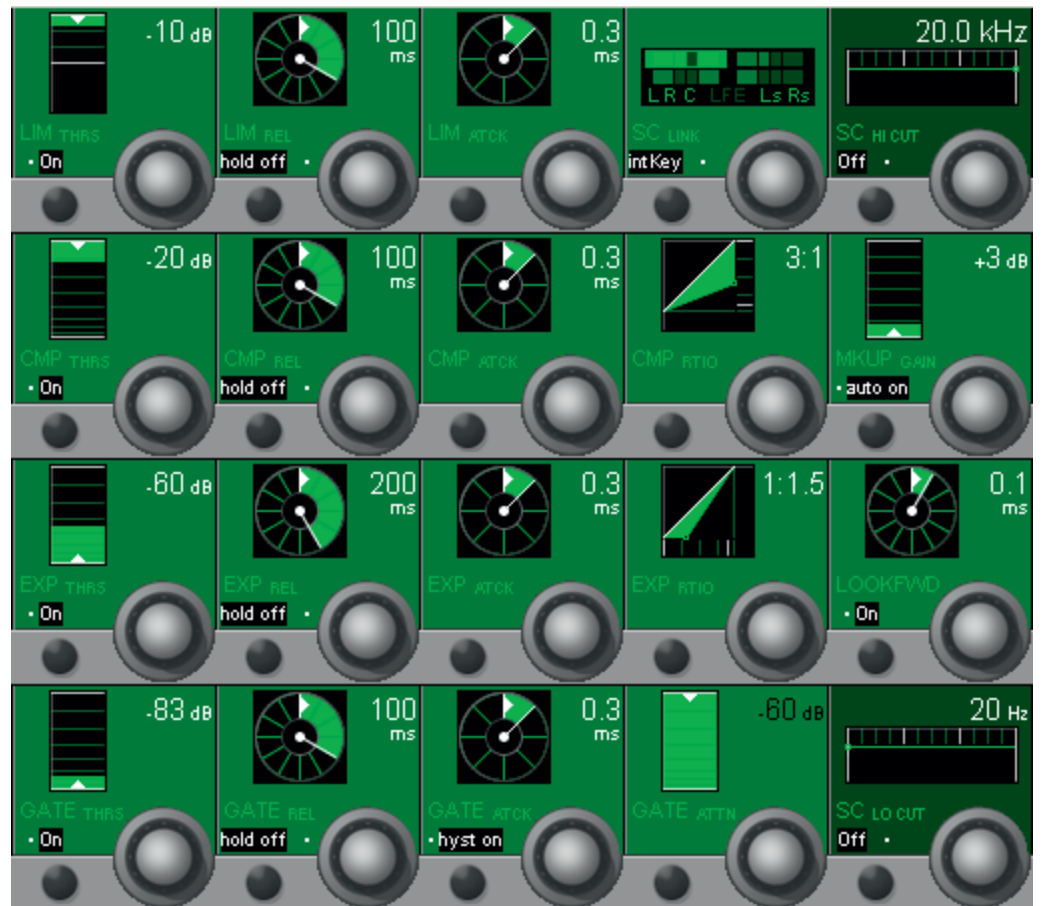

If a dynamics setting has been made on a 5.1 surround channel, the default Vistonics dynamics display shows in small characters which signal leg is different from the others (in this case, only 'Lf' is shown since the LFE's EQ setting is not modified), as shown left.

If one or more of the signal legs must be adjusted differently from others – such as adding expansion in the center channel only, the **CHANNEL VIEW** has to be selected. Then all the separate dynamics settings for 'Front', 'Center', 'LFE' and 'Rear' are accessible. Please note that there also is a gain reduction indication at the left of each of the four individual dynamics icons.

Parameters Shared by the Dynamics Functions

SC LINK

The Side-Chain Link function allows forming a side-chain group from up to eight channels in order to control the dynamics of all of them by the maximum level of all side-chain group members. Side-chains are defined in the GC's Channel Patch window ('Sidechain Link Setup', tick 'Enable side Chain Link'). The rotary encoder selects the surround signal legs used for the side-chain group; for details, see the block diagram below.



Four different possibilities are available:

All signal legs (L, R, C, Ls, Rs) are part of the sidechain link.

Only the L, R, Ls and Rs signal legs are part of the sidechain link.

Only the L, R and C signal legs are part of the sidechain link.

Only the L and R signal legs are part of the sidechain link.

SC LINK intKey/extKey

The key source input can be selected from intKey (dynamics processing depends on the channel's own input signal, i.e. an internal key signal), or extKey (processing is controlled by a signal connected via the patch, i.e. by an external key signal).

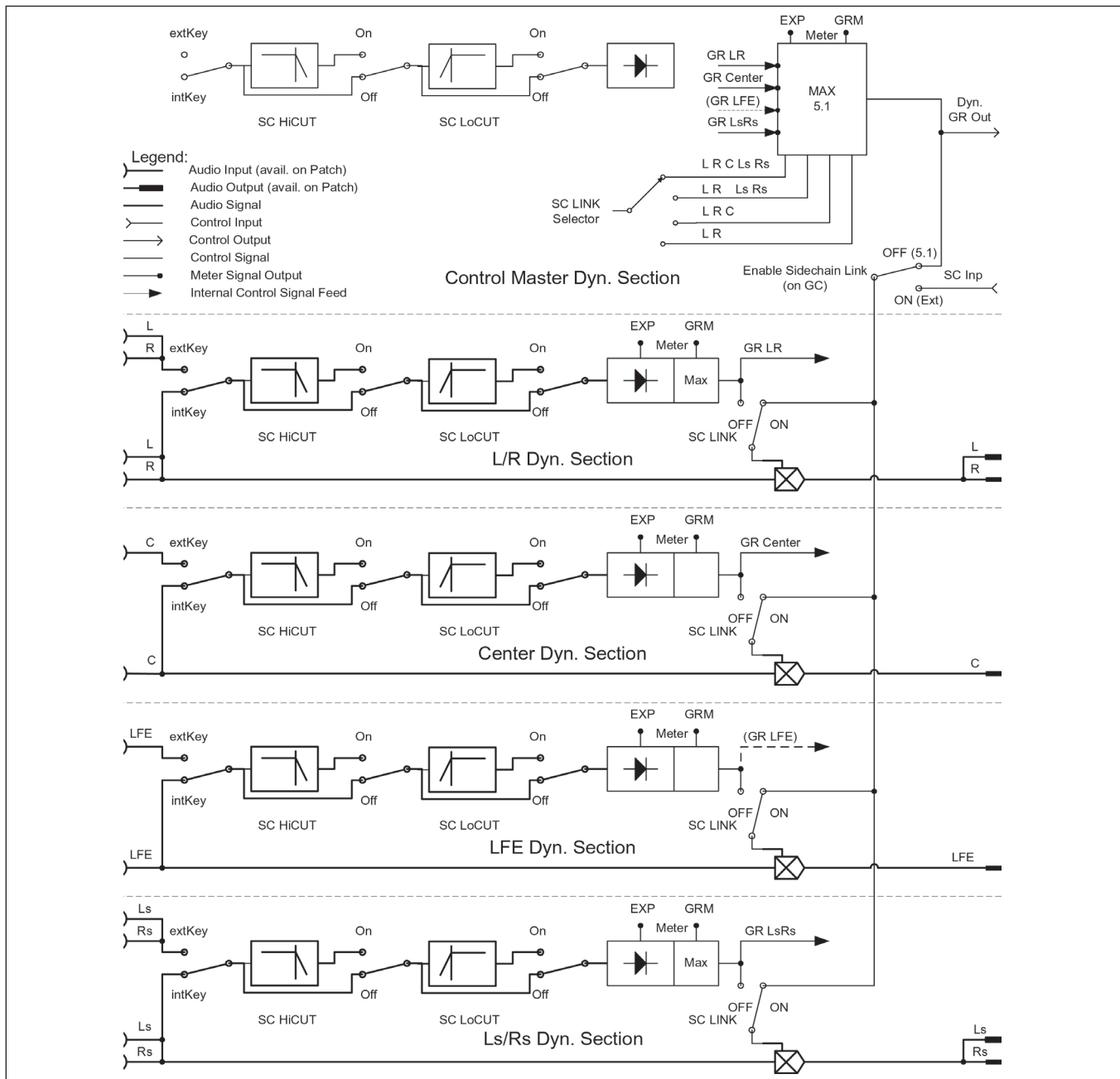

3.4.3.3 Vintage Dynamics

Please note that the vintage dynamics section is available for mono and stereo channels only.

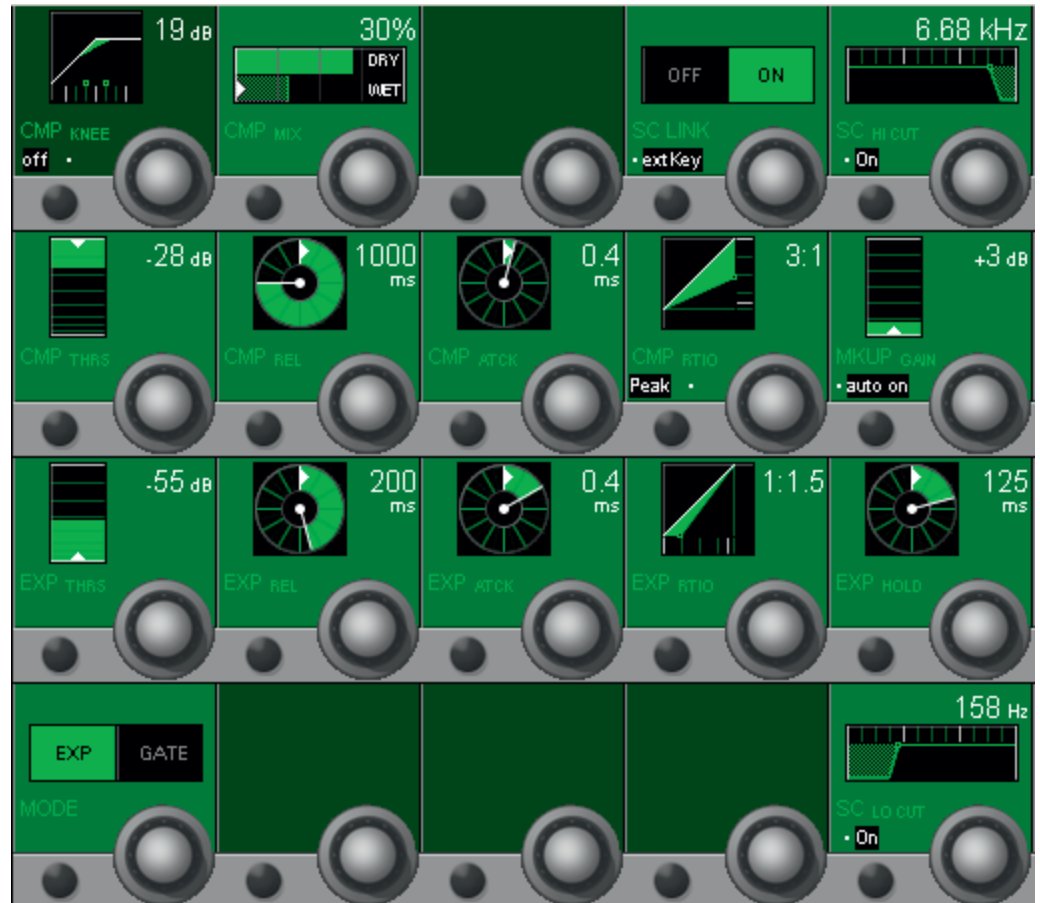

The main differences between the vintage and standard dynamics sections is that the vintage dynamics are intended as an effect rather than being transparent. Its compressor has some additional parameters compared with the standard dynamics section, but no hold function instead; there is no limiter available, and the expander and gate sections cannot be used at the same time. Below, only the parameters different from the ones of the standard dynamics section are described.

Vintage Compressor Parameters:

- CMP KNEE Rotary** The smooth transition ('soft knee') at the compressor threshold can be adjusted, the window size can be set between 0 and 60 dB.
- CMP KNEE on/off** Switches the compressor's 'soft knee' on or off.
- CMP MIX Rotary** If the CMP MIX function is on, this parameter allows mixing or blending of the dry (original) and the wet (compressed) signals. 0% setting: dry signal only; 100% setting: wet signal only.

CMP MIX on/off	Rotary	<p>‘on’ activates the CMP MIX function; ‘off’ selects the compressed signal only.</p> <p>When the CMP MIX function is set to ‘on’, the ratio of the dry (original) to the wet (compressed) signal depends on the selected mix ratio. In other words, mixing between the original and the compressed signals is possible.</p>
CMP REL	Rotary	The compressor release time can be adjusted within a 5 ms to 5 s range.
CMP ATCK	Rotary	The compressor attack time can be adjusted in steps within a 200 μ s through 250 ms range.
CMP RTIO	Rotary	The compressor ratio can be adjusted from 1:1 (no compression) through 40:1 (very heavy compression).
EXP / GATE MODE	Rotary	Used for selecting <i>either</i> the expander <i>or</i> the gate function for the vintage dynamics section. <i>The threshold, release, attack and hold parameters of expander and gate are adjusted in common; they cannot be set individually.</i>
EXP / GATE REL	Rotary	The expander/gate release time can be adjusted within a 5 ms through 5 s range.
EXP / GATE ATCK	Rotary	The expander / gate attack time can be adjusted within a 0.5 through 5 ms range.
EXP RTIO	Rotary	The expander ratio can be adjusted from 1:1 (no expansion) through 1:40 (very heavy expansion).
EXP / GATE hold	Rotary	The expander / gate hold time can be adjusted within a 0 through 2 s range.

3.4.4 Panning Parameters

There are several panning options available. These range from a simple mono-to-left/right pan over a stereo direction pan with width control to the sophisticated family of *Virtual Surround Panning* (VSP) modules. Left/Right and VSP functions are available for mono input, group, multi-track input, and multi-track monitor channels. Direction and Direction with Width functions are available for stereo input and group channels. In addition, there exist upmix panning functions for easily inserting stereo sources into surround mixes.

The panning functions can be controlled by the Vista's motorized joystick. To assign a channel to the joystick, press the joystick **FOLLOW** key (it will light) and then the **LINK/SEL** key for the desired channel. The joystick can be used to automate panning functions and then be reassigned to another channel by pressing the **LINK/SEL** key of this channel.

Note The **PAN** key in the **CHANNEL PROCESSING** area can be used for activating/deactivating for activating or deactivating the complete panning section of a channel (or a gang of channels) selected with **LINK/SEL**, in addition to the individual On/Off keys for the panning parameters. If the **PAN** key is de-activated, the channel signals are directly fed to all assigned busses, without being influenced by any panning.

LR PAN for Mono Channels The LR panning function is a simple PAN potentiometer controlling the contribution of the mono signal to the odd and even or left and right busses.

- PAN ON/OFF
- PAN function: Mono direction in 1° steps from -30° (L) to +30° (R).

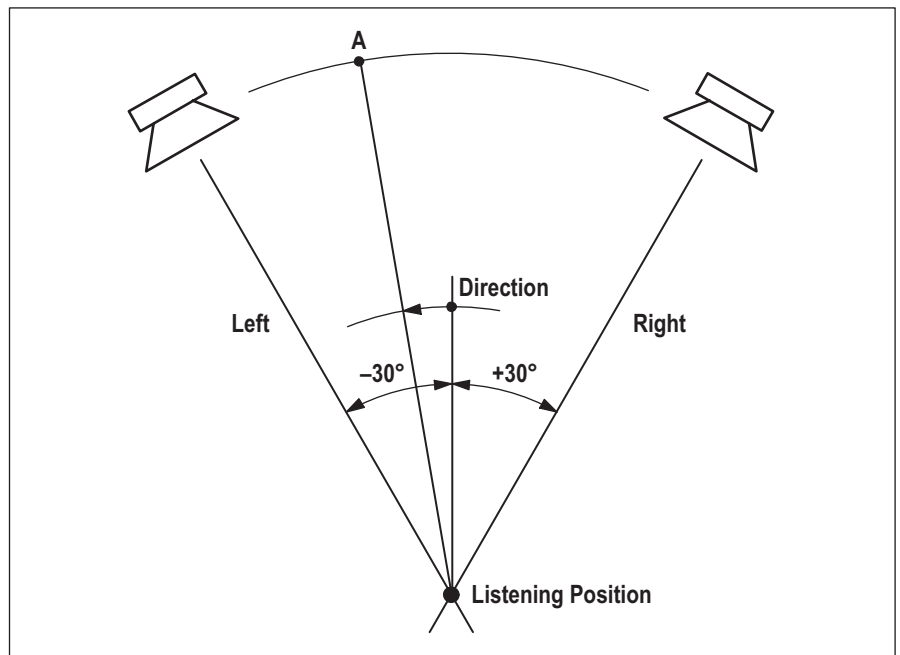

LR PAN for Stereo Channels

The PAN ON/OFF and PAN functions are extended to enable working with either standard (L/R) stereo or with MS (mono/side) signals. In addition, features are available to increase the stereo image manipulation possibilities, such as

- Input direction or
- Input balance,
- Stereo width (pan width), and
- Stereo direction.

Whether the stereo width function is available depends on the currently loaded configuration.

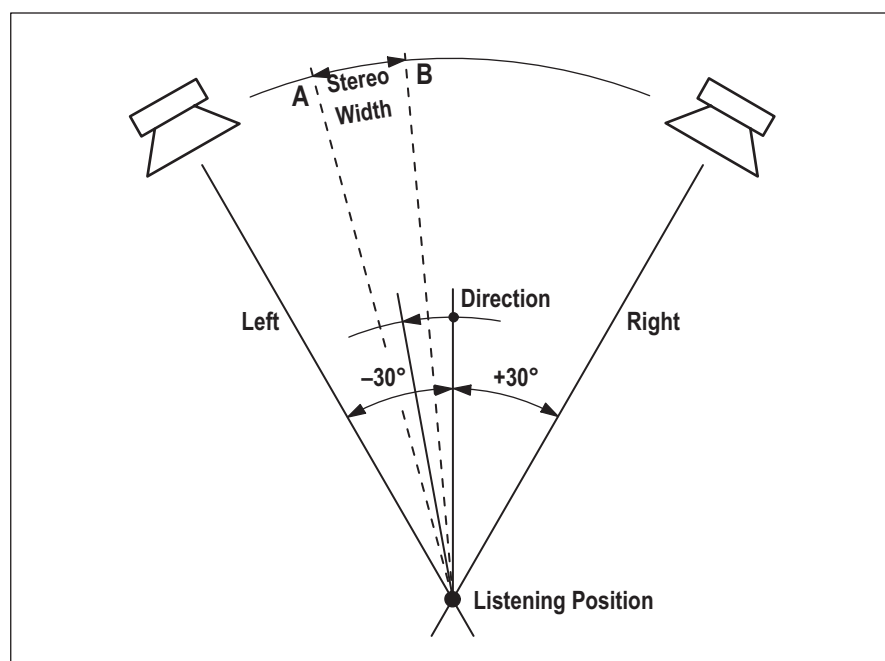

Virtual Surround Panning (VSP)

Various surround panning algorithms can be used for mono input, group, multi-track input, and multi-track monitor channels; this depends on the currently loaded configuration.

Basically, two different surround panning algorithms are available: Multi-format pan, and VSP (Virtual Surround Panning), see table; some more information on these algorithms is given in the ‘Parameters’ sections below.

Algorithm:	Format 2-CH to 7.1-CH	LCR, F/B, Ls/Rs Pan	Divergence	Seamless Center Channel Usage	Pan Mode	VSP Controls: Ambience, Distance, Absorption, Room Size
Multi-Format Pan	X	X	X	X	Amplitude	–
VSP Pan	X	X	X	X	Amplitude, HRTF, Sphere, ORTF, AB	X

Depending on the currently loaded configuration, one of the or both algorithms above may be present in the console at a time.

3.4.4.1 Amplitude Panning Parameters

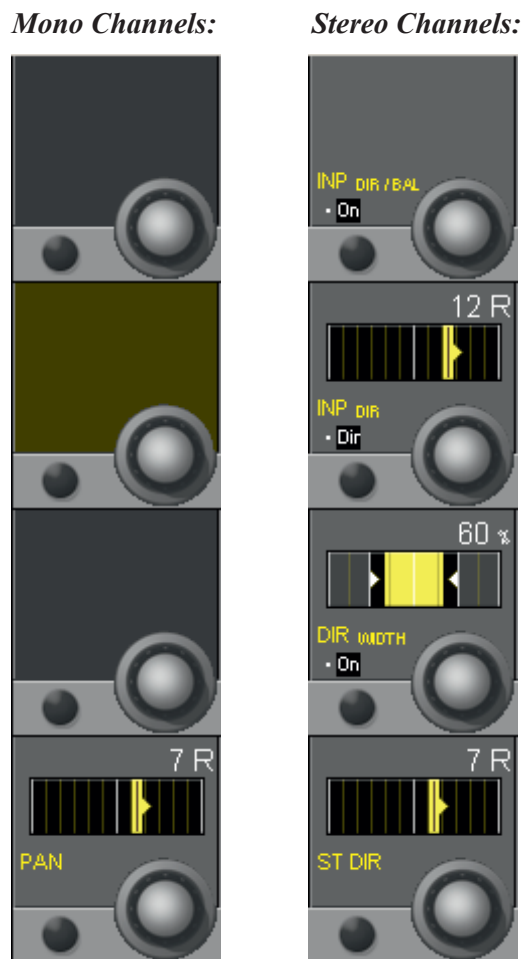

LR Panning Parameters for Mono Channels:

Mono channel LR PAN has only one panning function: left/right panning. It is useful for left/right panning to stereo master or group busses, or for odd/even panning to group or multi-track busses.

General PAN On/Off is selected with the **PAN** hardware key above the Vistonics section.

PAN Rotary The rotary encoder provides left/right (odd/even) panning control in 1° steps from -30° (fully left) to +30° (fully right).

LR/Direction Panning Parameters for Stereo Channels:

Stereo channel DIR/BAL PAN is a stereo direction panning function. It is useful for controlling the direction of stereo signals to master, group, and multi-track busses.

DIR WIDTH is identical to the DIR pan with an optional width control added (depending on the currently loaded configuration).

PAN On/Off is selected with the **PAN** hardware key above the Vistonics section.

INP DIR / BAL On/Off Activates the input balance or the input direction control, depending on the function selected with INP BAL / INP DIR. This function is placed within the signal path of the channel *before* the mono switch, selectable in the '2CH mode' section.

INP DIR / BAL	Selection from two input functions: INP BAL <i>or</i> INP DIR.
INP DIR / INP BAL Rotary	<p>The INP DIR function is used to control the <i>direction</i> of a stereo input signal. Turning the rotary encoder shifts the input direction in 1° steps from -30° (left) to +30° (right).</p> <p>The INP BAL function is used to control the <i>balance</i> of a stereo input signal. Turning the rotary encoder to the left attenuates the right channel from 0 to -∞ dB while the left channel remains at full input level, and vice versa.</p>
DIR WIDTH On/Off	<p><i>Optional, only if the width function is configured.</i></p> <p>Switches the DIR WIDTH function on/off.</p>
DIR WIDTH Rotary	<p><i>Optional, only if the width function is configured.</i></p> <p>The DIR WIDTH parameter is used to control the width of the stereo signal. It is only functional if there is a difference between the left and right input channels, or if IBAL or IDIR has been used to create an offset between the channels. The ST DIR control directs the position of the stereo signal, while the DIR WIDTH control determines the <i>width</i> or <i>stereo spread</i> either side of that position. DIR WIDTH operates over a range from 0% (mono) to 200% ('super stereo').</p>
ST DIR Rotary	Left/right (or odd/even) panning control for a stereo output signal in 1° steps from -30° (fully left) to +30° (fully right).

3.4.4.2 Upmix Panner Parameters (for Stereo Channels only)

Still a significant number of stereo sources is used for a typical surround production, so these need to be brought into the 5.1-channel format. The *upmix panner* is a way to pan stereo signals to a surround mix, providing the possibility to ‘unwrap’ a simple stereo signal to a surround sound field. Every stereo channel can be equipped with the upmix panner. There are three operating modes: ‘Normal LR’, ‘5.1’, and ‘5.1 width’ modes. ‘LR’ mode is normal stereo panning; ‘5.1’ mode uses ‘standard’ amplitude panning, where e.g. the left channel is sent to the left surround speaker, etc. The most uncommon of these modes is ‘5.1 width’.

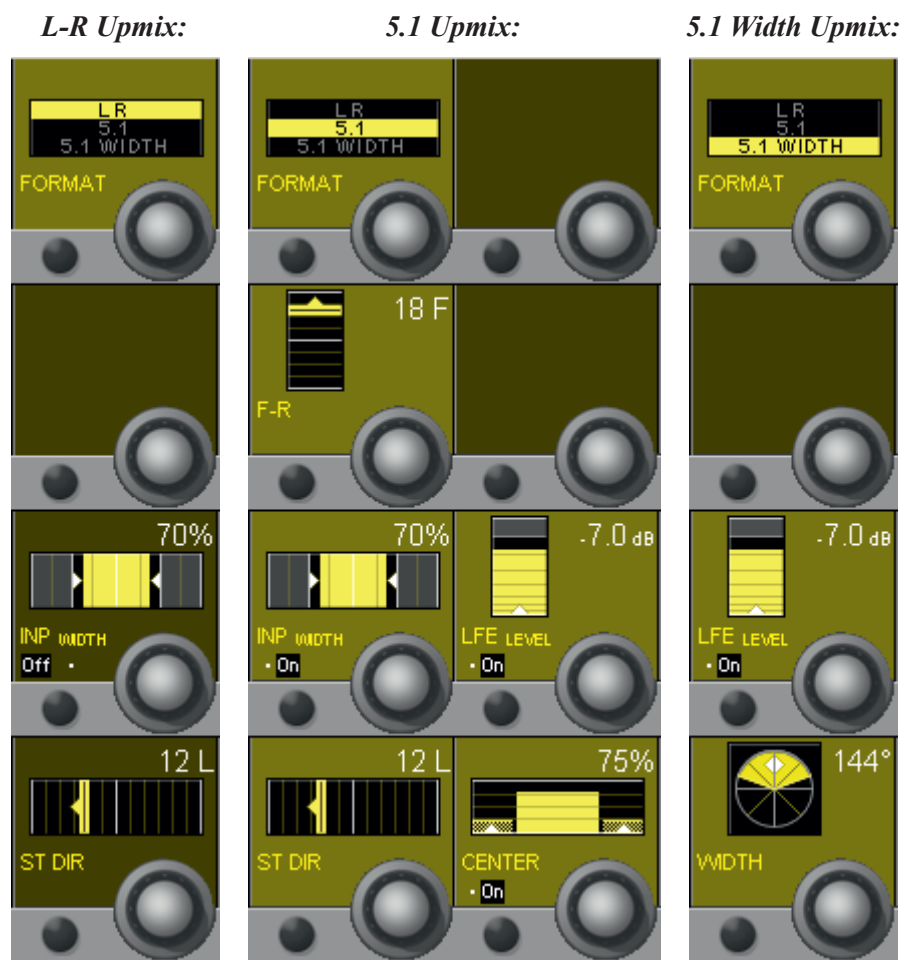

FORMAT Selector for the upmix panning mode.

The remaining parameters are the same as described in the chapters before, with one exception:

WIDTH in 5.1 WIDTH mode. This is a special algorithm (using Harman corporate intellectual property), extending the stereo width control to the rear channels as well.

3.4.4.3 Multi-Format Panning Parameters

Surround panning consists of two panning algorithms: Multi-format panning, and VSP (Virtual Surround Panning). These support a variety of surround formats and applications; in all these modes, an LFE (Low Frequency Effects) control is available. *Multi-format panning functions can be used only for mono channel types.*

Please note that the view below shows 5.1 panning format; for other panning formats, one or more of the fields may be blanked.



General PAN On/Off is selected with the **PAN** hardware key above the Vistonics section.

LFE On/Off On/off control for the Low Frequency Effects channel.

LFE LEVEL Rotary LFE level control from MUTE (i.e. $-\infty$ dB) to +10 dB.
Within this section, no filtering is applied to the signal fed to the LFE bus.

FRONT L-R Rotary This parameter controls the front panning between the left, (left-center, center, right-center), and right channels in 1° steps. The contribution to the center channel is determined by the **CENTER** rotary control.

F-R Rotary This front/rear parameter provides panning between front channels (LCR) and the rear channels (left and right surround) in 60 increments.

REAR L-R Rotary This parameter controls panning between the left and right surround channels.

FORMAT Rotary	This serves as the format selector in all multi-format panning modes. The following selections are possible: L-R, LCR, LCRS, 5.1, EX, and 7.1. <i>Depending on this selection, the actually required parameters are displayed.</i>
PANARND On/Off	This key activates the unique Pan-Around function. <i>If active, the FRONT L-R, F-R and REAR L-R controls become inactive.</i>
PANARND Rotary	This is a single-knob function that provides an easy-to-use pan setting around all selected loudspeakers (depending on format) in a circular fashion. <i>If active, the FRONT L-R, F-R and REAR L-R controls become inactive.</i>
CENTER On/Off	On/off selector for center channel use.
CENTER Rotary	Center channel percentage control; 0% = no center channel use (phantom center), 100% = center channel fully active.
DIVERGE Off/Front/All	Divergence mode selector. The divergence function can be applied to panning between all channels or the front channels only. The key toggles between off, front and all.
DIVERGE Rotary	The divergence function is used to bleed portions of sound from the panned output to the other speakers. For example, if the divergence is active and set to 100%, the LR control will act as a traditional L/R pan pot (assuming there is no center channel contribution). Panning to full left will result in full attenuation of the right channel. If the divergence is then set to 50%, one half of the left channel signal strength will be <i>bled</i> into the right channel (without effecting the left channel). With the divergence control set to 1%, equal signal will be fed to both channels and the LR pan pot will have no effect. Divergence values are as follows: 1%, 2%, 3%, 4%, 5%, 10%, 15%, 20%, 25%, 30%, 35%, 40%, 45%, 50%, 60%, 70%, 80%, 90%, 100%. Careful use of this control may have the effect of increasing the size of the mix ‘sweet spot’, particularly for large auditoria. Misuse of this control may result in essentially mono panning.

3.4.4.4 VSP Panning Parameters

Please note that the controls within the left part of the screenshot below are identical with the ones in [chapter 3.4.4.2](#) – for details, please refer to the description in that chapter.

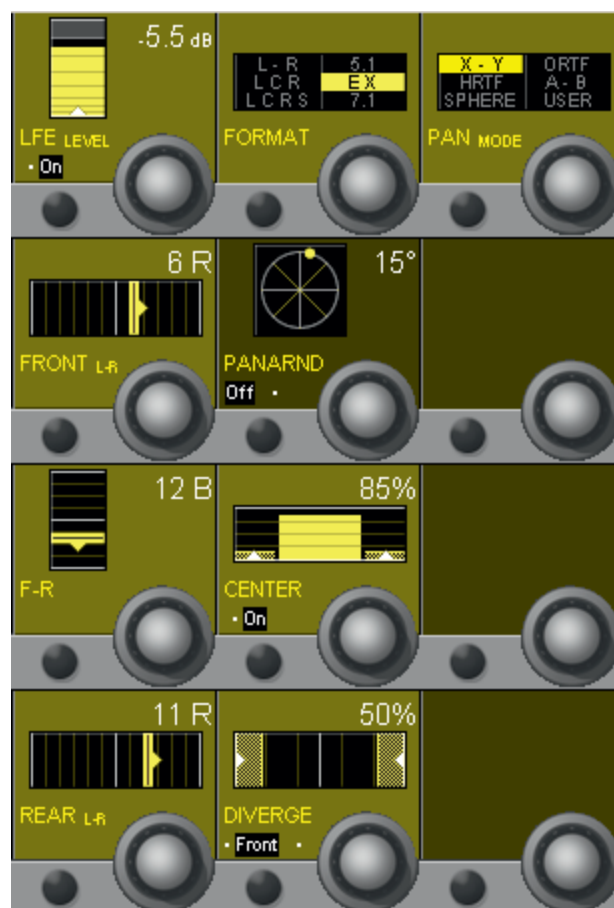

PAN MODE Rotary

Sets the overall panning algorithm used for positioning the mono source in the desired virtual location. In all but the X-Y mode, a stereo microphone simulation is employed which will yield a more diverse sound field.

- **X-Y** – A standard panning algorithm that only changes the amplitude of the signal to the various busses in relation to the position of the panner. This operation is well known and is used in all conventional panners.
- **HRTF** – Mainly a cross-talk canceler using simplified HRTFs (Head Related Transfer Functions). If the listener is positioned exactly in the sweet spot of a $\pm 30^\circ$ speaker setup, an extreme panning position like full left should affect the signal such that it will only be heard with the left ear and cancelled out on the right. It may also be used for enlarging the perceived width of a recording.
- **SPHERE** – This mode emulates a spherical microphone as shown in [chapter 3.4.4.6](#). The spherical microphone has two capsules mounted into a sphere having a diameter of about 18 cm. The sphere incorporates different effects on the two channels, including amplitude, delay and shadowing of the high frequencies on the channel which is not facing the source. This mode is only useful in two-channel mode, and presents a very accurate sound field.

- **ORTF** – An idealized version of the common cardioid microphone setup according to angles and distances used for stereo miking. A more accurate sound field is created through the manipulation of both amplitude and time differences.
- **A-B** – An idealized version of the common setup using omni-directional microphones. With this mode the sound stage is perceived as large, and is useful for solo instruments, audience, and choir. The positioning of the source is only established by changes in time delays.
- **USER** – When this mode is selected, the panning algorithms are established from the Microphone User Settings interface provided under the main Option menu in the system Graphical Controller. The settings made affect the relationship between amplitude and time differences, determined by the settings of the imaginary microphones. For details, see [chapter 3.4.4.6](#).

3.4.4.5 Panning Parameters for 5.1 Surround Channels

Touch the yellow Vistonics pan field.

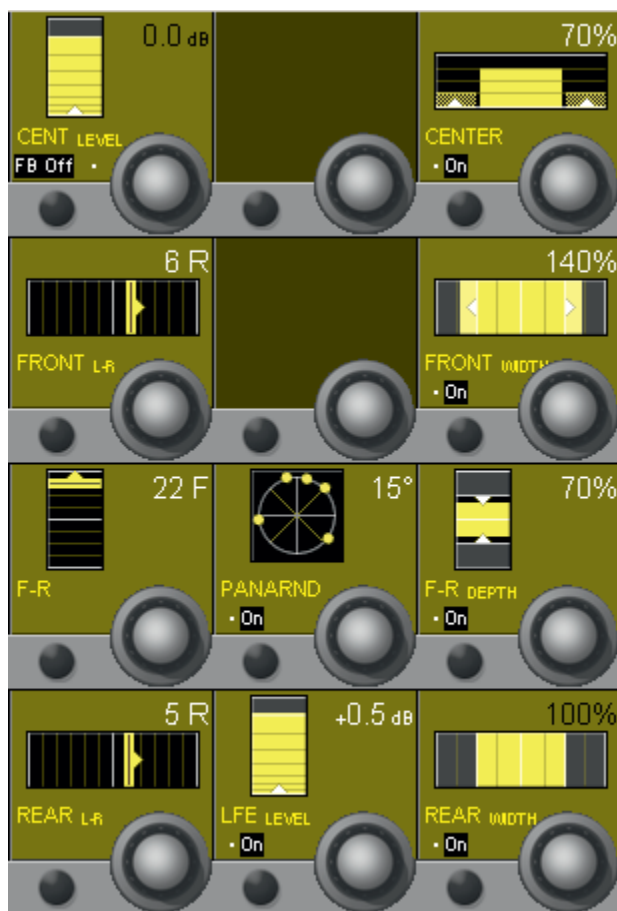

General PAN On/Off is selected with the **PAN** hardware key above the Vistonics section.

CENT LEVEL Center level control from MUTE (i.e. $-\infty$ dB) to +10 dB.

FB On/Off On/off switch for center channel contribution to the F-R control.

FRONT L-R Front panning between the left, (center) and right channels in 1° steps. The contribution to the center channel is determined by the **CENTER** control.

F-R This parameter allows variable blending from front to rear channels in 60 increments, either with a contribution from the center channel (**FB On**) or without (**FB Off**).

REAR L-R Panning between the left and right surround channels in 1° steps.

PANARND On/Off Activates the Pan-Around function.

PANARND Single-knob function, allows rotating the surround sound field by $\pm 180^\circ$.

LFE On/Off On/off selector for LFE channel use.

LFE LEVEL LFE channel percentage control; 0% = no LFE channel use, 100% = LFE channel fully active.

CENTER On/Off	On/off selector for center channel use.
CENTER	Center channel percentage control; 0% = no center channel use (phantom center), 100% = center channel fully active.
FRONT WIDTH On/Off	Switches the FRONT WIDTH function on/off.
FRONT WIDTH	The FRONT WIDTH parameter is used to control the width of the front signal. It is only functional if there is a difference between the left and right input channels. FRONT WIDTH operates over a range from 0% (mono) to 200% ('super stereo').
F/R DEPTH On/Off	Switches the F/R DEPTH function on/off.
F/R DEPTH	The F/R DEPTH parameter is used to control the depth of the surround space. It is only functional if there is a difference between the front and the rear input channels. F/R DEPTH operates over a range from 0% (zero depth) to 200% ('super depth').
REAR WIDTH On/Off	Switches the REAR WIDTH function on/off.
REAR WIDTH	The REAR WIDTH parameter is used to control the width of the rear signal. It is only functional if there is a difference between the left and right input channels. REAR WIDTH operates over a range from 0% (mono) to 200% ('super stereo').

3.4.4.6 Microphone Simulation Tool (MST) – User Pan Mode

As a further sophistication of the VSP system, a Microphone Simulation Tool (MST) has been created. This allows the mix engineer to create his/her own multi-channel panning law, by simulating the placement of microphones in a virtual space.

Overview

A user can define how the VSP varies the delays and amplitudes of the direct sound when panning between speakers. To instruct the VSP how to generate these signals, commonly known microphone symbols are used. Each symbol represents the signal that will be sent to one speaker.

For example, if five omni microphones are set up at the same position, no panning effect will be achieved. Five omni microphones at certain distances will only create time differences when panning between speakers. Five shotgun microphones positioned in one location will only generate amplitude differences. And five directional microphones positioned in different locations will generate both amplitude and time differences between the speakers (based on the placement of the ‘microphones’).

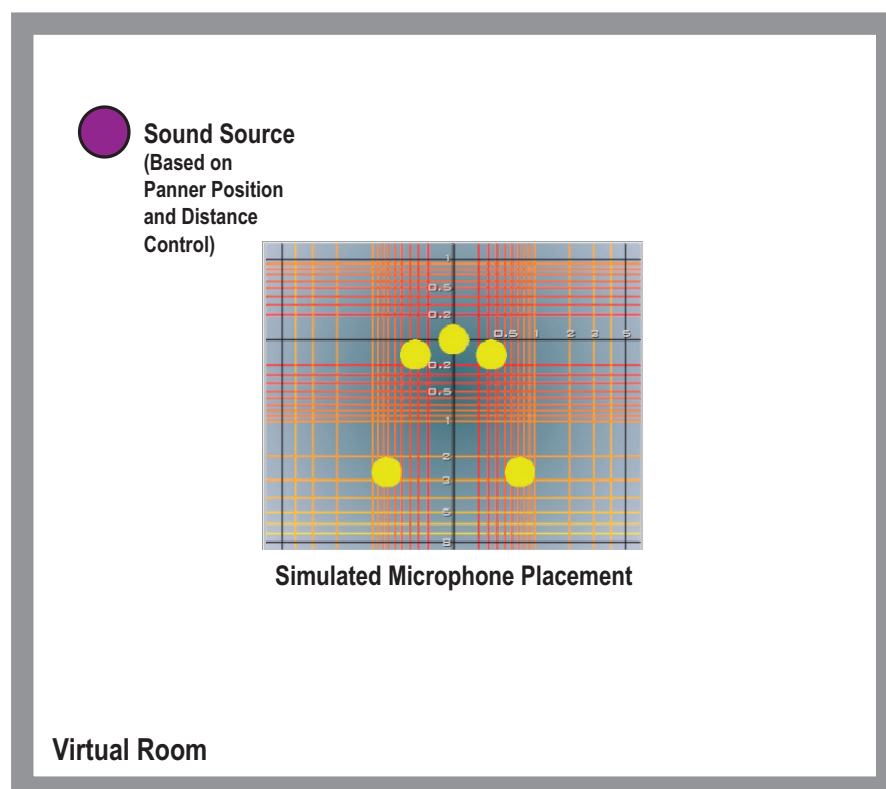

The dry signal within a VSP channel is now placed to an imaginary position based on the panner positioning within the channel. You can now imagine that, if each speaker (in your monitoring environment) is fed the signal based on the placement of the ‘microphones’ in the simulation (including the reflections), that a realistic sound space could be achieved. This is a simplification of what happens within the VSP system.

Each of the Panner modes (ORTF, AMP, AB, etc.) simulates a different placement of the microphones, and therefore yields a different acoustic scene.

Here are the placements for some of the Panner Mode presets:

ORTF (With Surrounds)

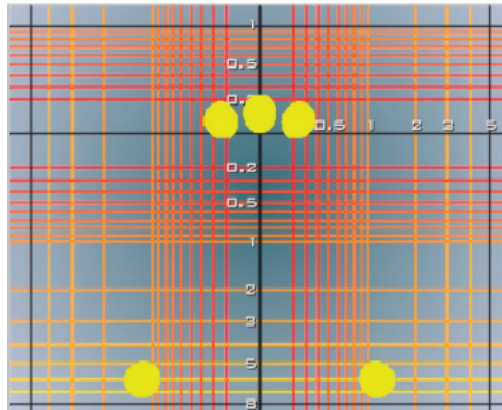

The amplitudes vary due to the directionality of the microphones, while time delay is varied based on the distances between the microphones (each of them feeding a speaker).

AB (With Surrounds)

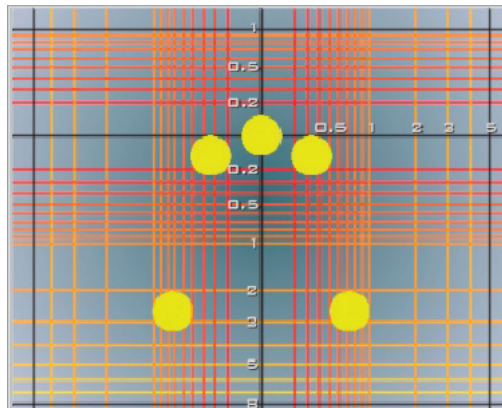

Because all microphones are omni-directional, the amplitude is the same for all of them, but the delay differs due to the distances between the microphones.

Sphere



The Sphere setting is based on a microphone as shown in the picture above. Amplitude, phase and frequency response is calculated based on measured signals from such a microphone.

User Setting

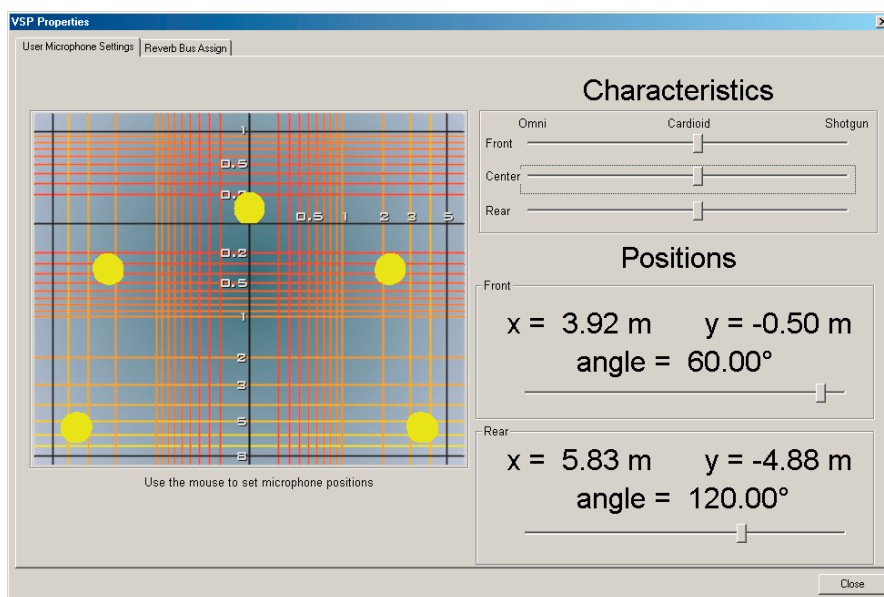

With the Microphone Simulation Tool, the mix engineer is able to set up his/her own microphone simulation using the dialog box available in the Options/VSP menu.

Microphone Positioning

The settings may be changed as follows:

The front left and right microphones may be moved by grabbing one of them with the trackball and positioning it as desired. The opposite microphone moves to a symmetrical location. The same may be done with the rear left and right microphones. The center microphone cannot be moved.

Microphone Pattern

The front, center, and rear microphones may be independently changed as to their polar characteristics. This may be done using the sliders. Each pattern can be changed from omni-directional to shotgun.

Microphone Angle

The Front and Rear microphones may also be independently changed as to their positioning angle. This may be done using the angle sliders, or by double-clicking and dragging with the mouse.

So when a VSP Channel Pan Mode is selected to the USER setting, the settings within the Microphone Simulation Tool will be used as a basis for the underlying VSP panning law. These settings may be changed in real time, and the changes will be audible as they are being made. This is an exciting and functional tool that the mix engineer now has exclusively with the use of the VSP panning system within the Studer D950 or Vista consoles.

3.4.5 VistaMix (VMX)

Basics Studer VistaMix is an automatic mix algorithm based on gain sharing, introduced with SW V4.9. VistaMix processing comes in very handy in multi-microphone situations, such as round-table discussions or unscripted games shows, in which indirect voice and early reflection-spill negatively affects the summed mix. It reacts faster and much more precisely than any human operator could possibly be, thus avoiding late fade-ins.

Working Principle The concept of VistaMix is to analyse the input channels assigned to the VistaMix group, and only open the gain of those channels that have active speakers talking. By reducing the gain of non-active talkers, spill, studio noise and ambience is greatly reduced. VistaMix calculates the gain of the contributing channels in such a way that the cumulative gain of all member channels always equals the gain value of one open microphone. This avoids modulation of the ambience and background noise. *Please note that this system does not use gates or expanders.*

The four situations in the example image below, with 3 speakers each, show the reaction of VistaMix (Gain) according to the actual individual input levels (dB SPL).

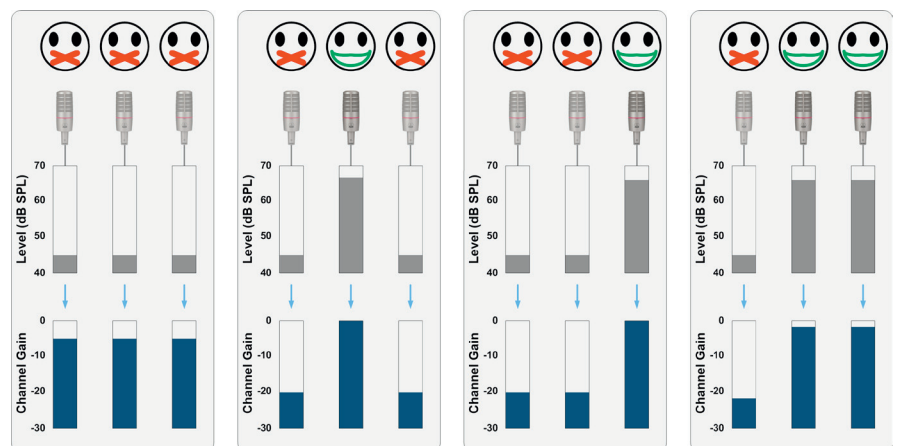

The VMX Bus VistaMix functionality is integrated into a new ‘VMX’ mix bus type, to which any mono channel can be routed. The VMX bus colour representation on the Vistonics screens is cyan. *Please note that stereo and surround channels may not be routed to VistaMix busses.*

There are two Bus types – mono and stereo output. Each type may be configured with 8, 12, 16 or 20 maximum contributing mono channels. Unlike conventional bus types, the VMX bus types can only be configured by adding a VMX channel. The configuration tool will then automatically construct the channel/processing/bus structure.

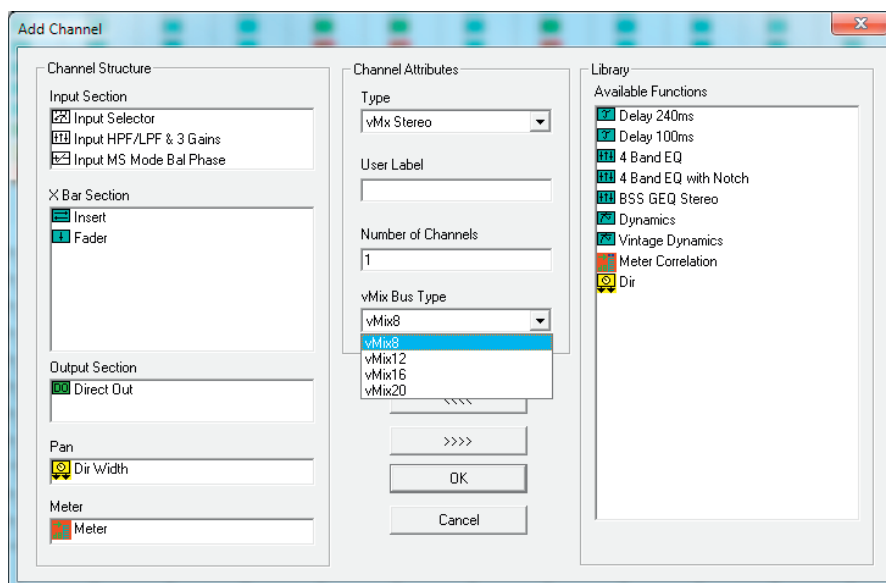

Several instances of both mono and stereo VistaMix channels may be configured in a single DSP configuration. If you wish VistaMix channels to slave or re-enter, you will need to add the appropriate bus links in the configuration tool's Channel Bus page. Naturally, normal channel DSP processing, such as EQ, dynamics etc., may be added as usual.

Contributing channels can be assigned to VistaMix busses from the regular bus assign view. The assignment is exclusive, that is, a channel can only be member of one VMX bus at the same time. Channels that feed a VMX bus will show one (mono vmx) or two (stereo vmx) miniature fader symbols in the label area of the Vistonics display. These show the gain of the VistaMix function dynamically and are *not* audio level meters.

Note: *Only mono channels can be assigned to VistaMix busses.*

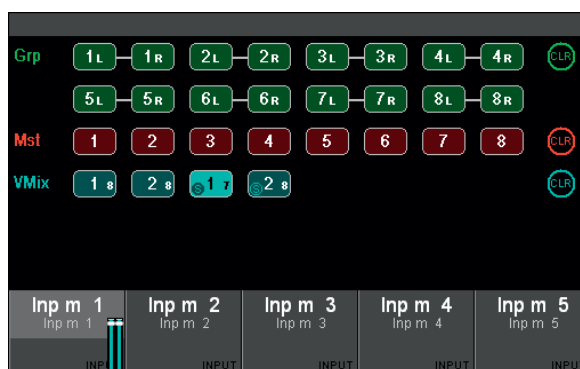

The audio to the VistaMix processing is always post fader from the source channel. It is also possible to route the post fader signal to 'normal' busses, AUXes, groups and masters, but no VistaMix gain control will be applied to these busses.

VistaMix Master Channel

Master channels will appear in cyan in the strip assign page and may be assigned to the faders in the normal way. The Vistonics view of the VMX bus parameters is opened by touching the Vistonics PAN icon of the desired bus.



The VMX bus parameters appear next to the channel's PAN parameters.

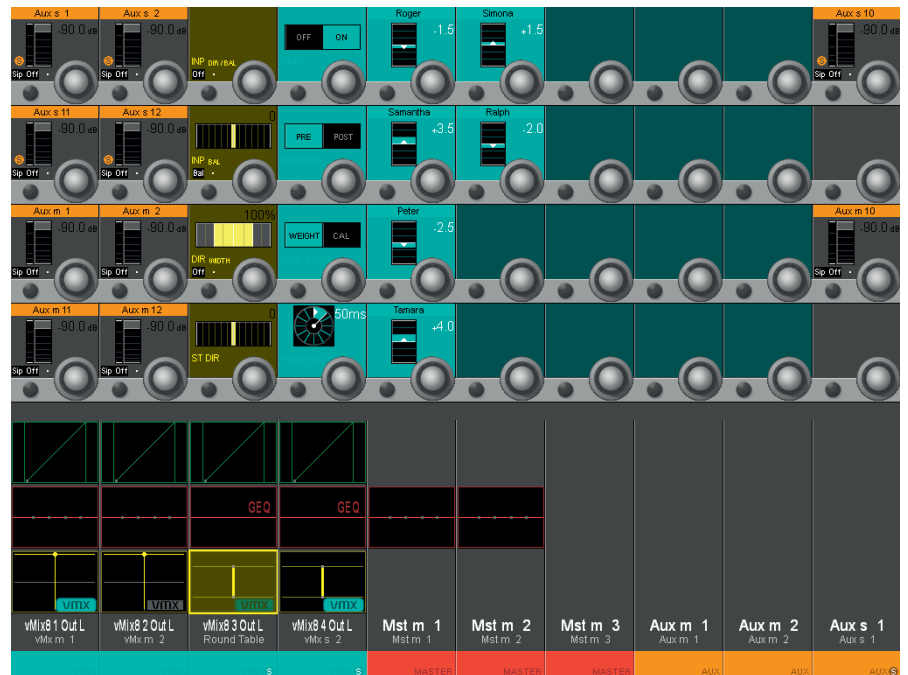

VistaMix Parameters

VMix



This parameter turns the VMX function On and Off.

In the Off state, the assigned channels' contributions to the bus are only depending on their input fader setting, as with usual channel contributions to standard busses.

Knob Assign



Changes the parameter value between CAL and WEIGHT that are both controlled on the contributing channels' side. Both CAL and WEIGHT of the contributing channels can be set either in the VMX bus parameters shown above or, after selecting **GLOBAL VIEW – DLY-INS**, with the lowest Vistonics knob in the corresponding channel strip.

During setup, first the CAL of all the talkers is set, adjusting the microphone balance in the mix when several talkers are speaking at the same time. If only one person is talking, the gain will not be affected. The contribution of the channels of the persons currently not talking is automatically adjusted in such a way that the ambience level remains constant.

WEIGHT can then be used to control the relative levels of persons (such as the moderator – Samantha in the example at the left) that are given priority over the other participants, so that this person gets more gain relative to the others in the mix, if several persons are talking at the same time. WEIGHT may also be helpful for a talker with a thin voice.

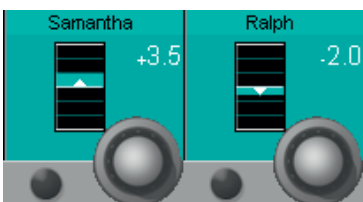

**Response Time**

The response can be set from 20 ms up to 4 s. Recommended setting is 50 ms but the engineer's ears have to decide. The response time cannot be compared with release and attack times of dynamic processes. This time sets how fast the crossfades between the calculated gain values are executed and how fast VistaMix is reacting on the occurring changes of the signals.

**Pan Mode**

The pan mode parameter defines where the PAN values of the individual contributing channels are calculated. This applies for stereo VistaMix master channels only (on mono VistaMix masters this parameter is automatically blanked).

Normally dialogue is kept pretty central or even mono, so this is not an issue. If however significant panning of the source channels is applied, then moving the source channel pan function may change the acoustic effect of VistaMix operation. Depending on the amounts of panning, there is a compromise between dialogue moving and background noise and spill changing.

Initial settings from the comparison table below are recommended. But some own experimenting will do no harm, and the final decision is up to the engineer's ears.

Pan Mode	Pro	Con	Panning Level Dependency	Recommended:
POST	Stable Speakers	Moving Ambience	Better for lower Pan values	Quiet environments and/or low pan values (Studio)
PRE	Stable Ambience	Moving Speakers	Better for higher Pan values	Loud environments and/or high pan values (Field)

3.4.6 Channel View in general

Pressing **VIEW: CHANNEL** brings up an overview for the selected channel, covering the whole Vistonics TFT. All parameters of a channel except for Dynamics, EQ, and Pan are shown in the rotary section.

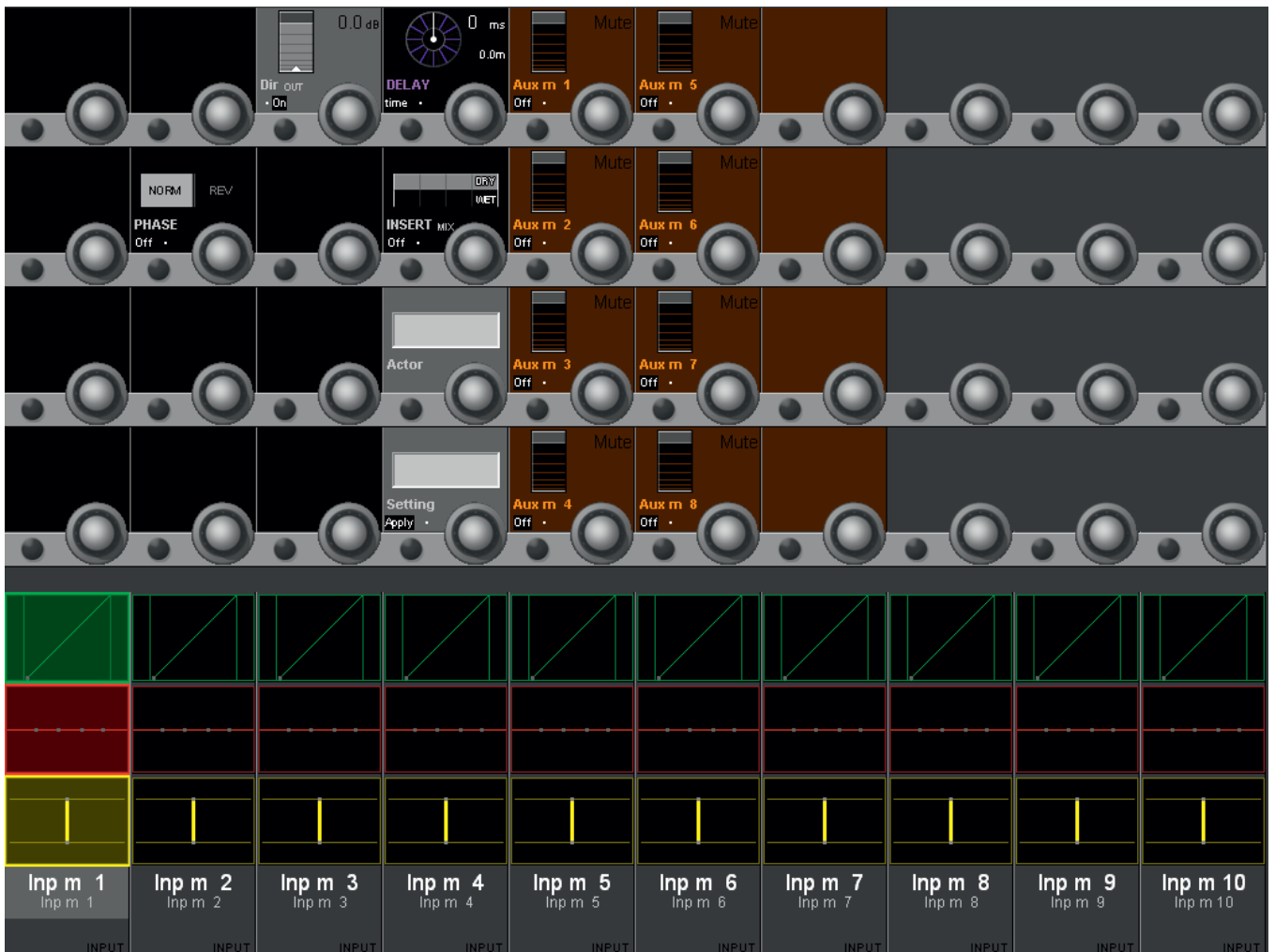

3.4.7 Channel View - Stereo Channel

From SW V5.3 onwards, an Input Gain Unfold can be found on stereo channels. This functionality allows the operator to have separate input gain levels on both legs of a stereo channel. As with the 5.1 channels, this feature can be found in the **CHANNEL VIEW**.

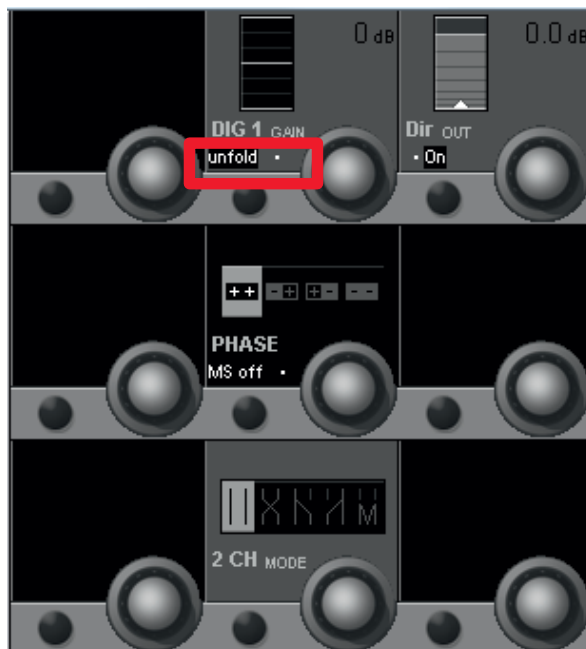

After pressing the **unfold** button, a new view reveals the two separate gain levels. With these L Gain and R Gain levels, the input gains can be set individually for the L and R channel leg. As soon as the L Gain and R Gain value differs from 0 dB, this is indicated with an “L” or “R” letter in the “main” Dig 1 Gain icon. The main Dig 1 Gain only acts as a “CGM” and remote controls the L Gain and R Gain values while keeping their offset.

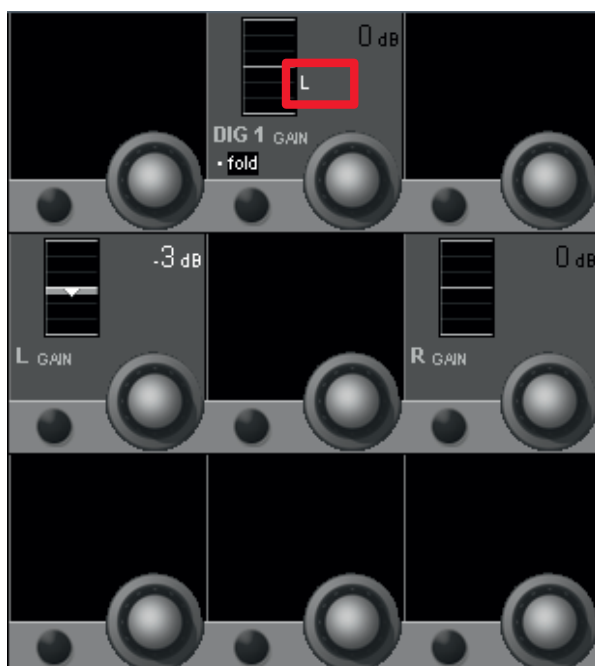

When using the **fold** button to go back to the normal **CHANNEL VIEW**, the individual input gains are kept and the main input gain control will then just apply an offset to the individual gains.

Note : Eventhough there is now a combination of two gain controls per channel-leg, the resulting digital gain range remains +/- 24 dB. This is visualized in the blockdiagram below.

Separate L Gain and R Gain levels are available for all three selectable inputs of the stereo channel (In1, In2, Gen).

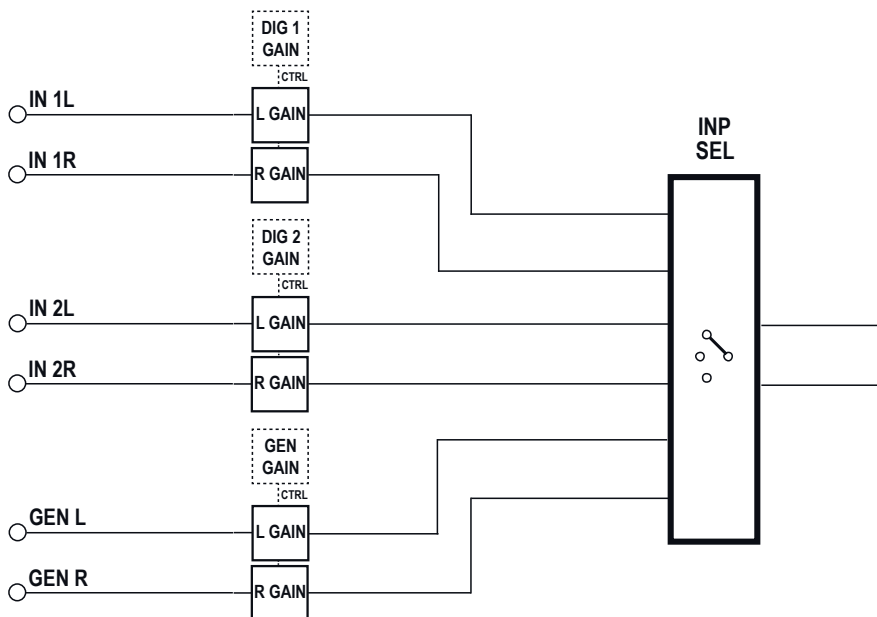

3.4.8 Channel View - 5.1 Surround Channel

Pressing **VIEW: CHANNEL** brings up an overview of the selected channel, covering the whole Vistonics TFT. All available parameters are shown in the rotary section, except for dynamics, EQ, and panning. Only visible parameters are available for adjustment.

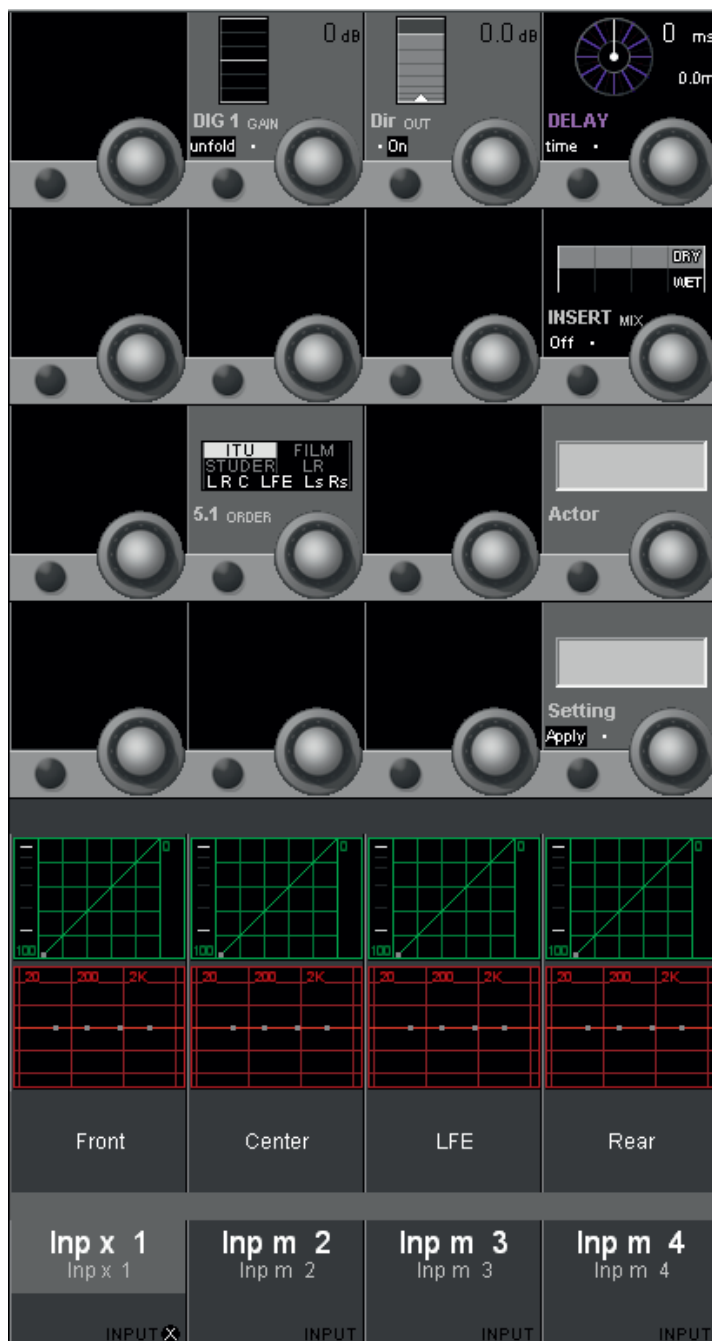

In this **CHANNEL VIEW** of a surround channel it is possible to **unfold** the input gain control DIG 1 GAIN. (As a difference to the input gain setting when shown in the **GLOBAL VIEW**).

When pressing the **unfold** key, the view changes again to reveal the input gain controls of all six surround signal legs. Here each signal leg can be trimmed individually.

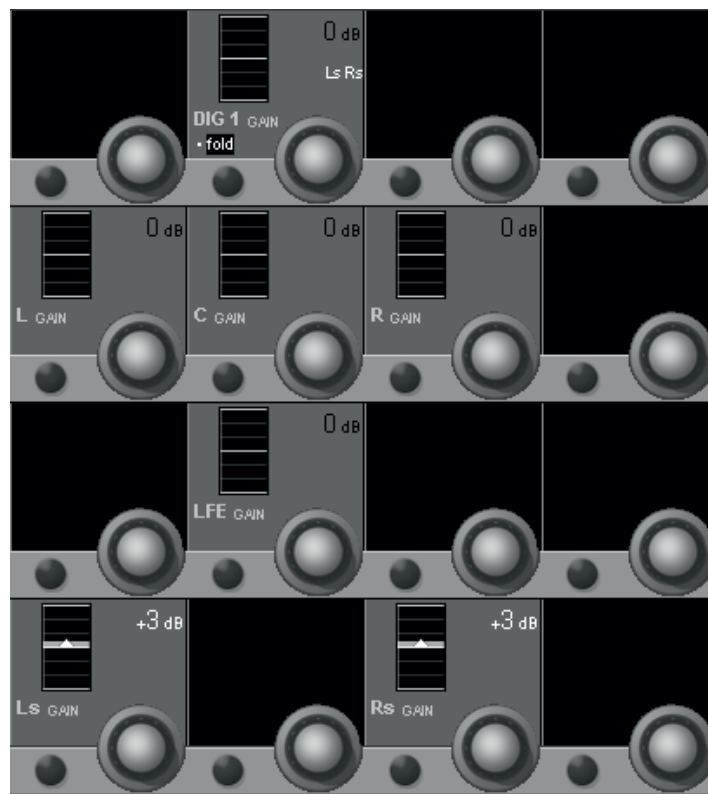

When using the **fold** button to go back to the normal **CHANNEL VIEW**, the trimmed input gains are kept and the main input gain control will then just apply an offset to the individual gains. Any trimmed input legs are then listed underneath the dB value. (As shown in the example above, where Ls and Rs are trimmed).

Also in the **CHANNEL VIEW**, there is an additional selection possibility in the touch area that allows modifying the EQ and dynamics parameters individually for the Front, Center, LFE and Rear signals.

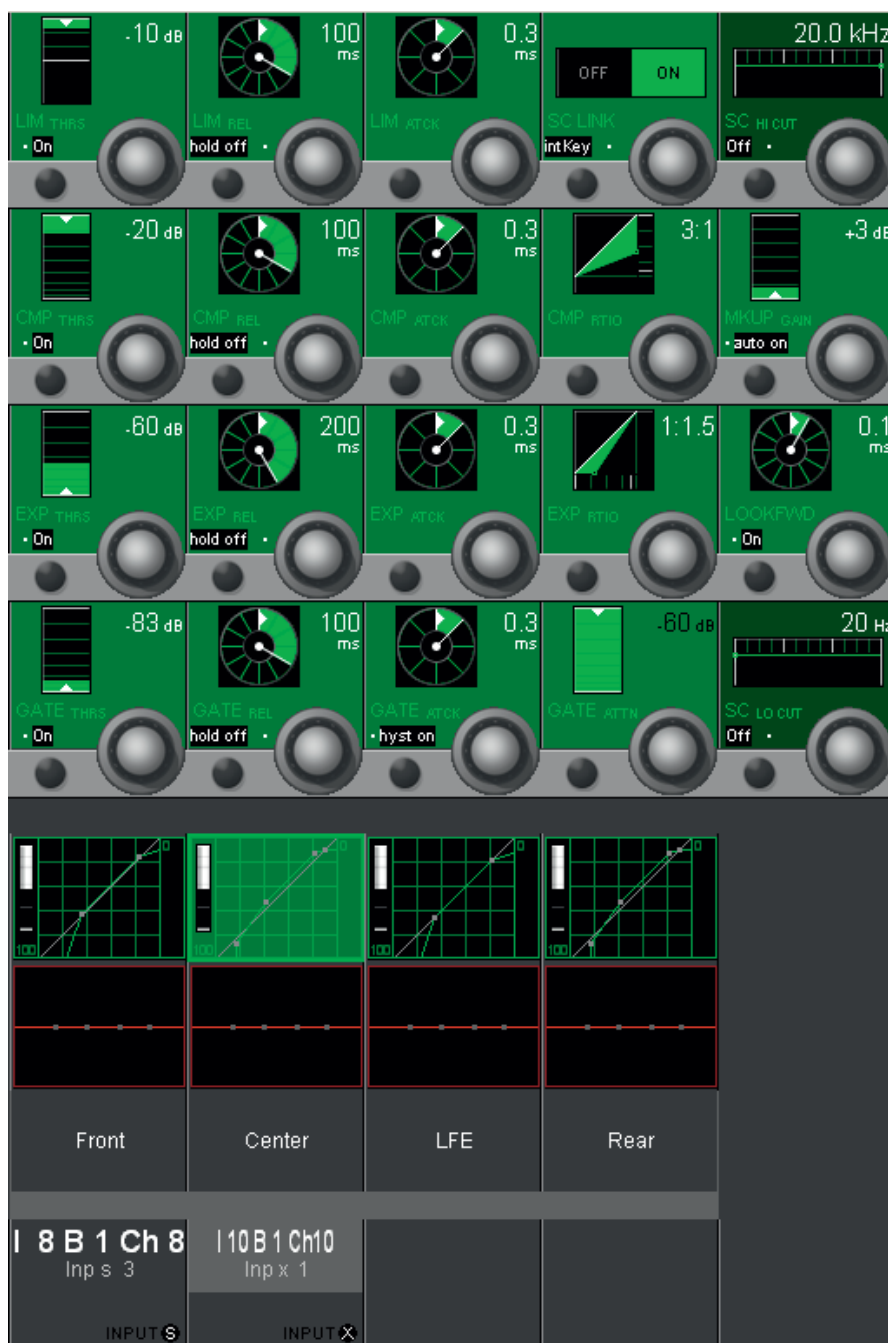

Upon touching one of these fields (e.g. the green 'Center' dynamics field) the display changes to the individual dynamics setting of the 'Inp x 1' 5.1 input's center channel.

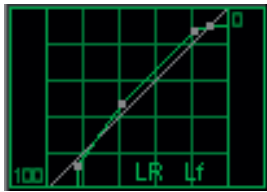

After the individual setting has been made, pressing **VIEW: CHANNEL** again switches back to the standard channel view. In our case (where the front and LFE channels of Inp x 1 have individual dynamics settings), the dynamics field then displays the standard dynamics curve with supplementary, small L, R and Lf characters, indicating that the front and LFE dynamics settings are different from the displayed curve. A gain reduction bargraph is shown at the left of each of the four individual dynamics icons.

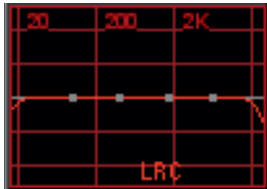

Individual EQ settings for the different surround signal legs can be adjusted and are indicated in the same way.

3.4.9 Misc View (Miscellaneous Parameters)

Pressing **VIEW: MISC** brings up an overview for the channel selected with the **LINK / SEL** key, covering the whole Vistonics TFT. The *most important* parameters of a channel's dynamics, EQ, and pan sections are shown in the rotary section. Only the visible parameters are available for adjustment.

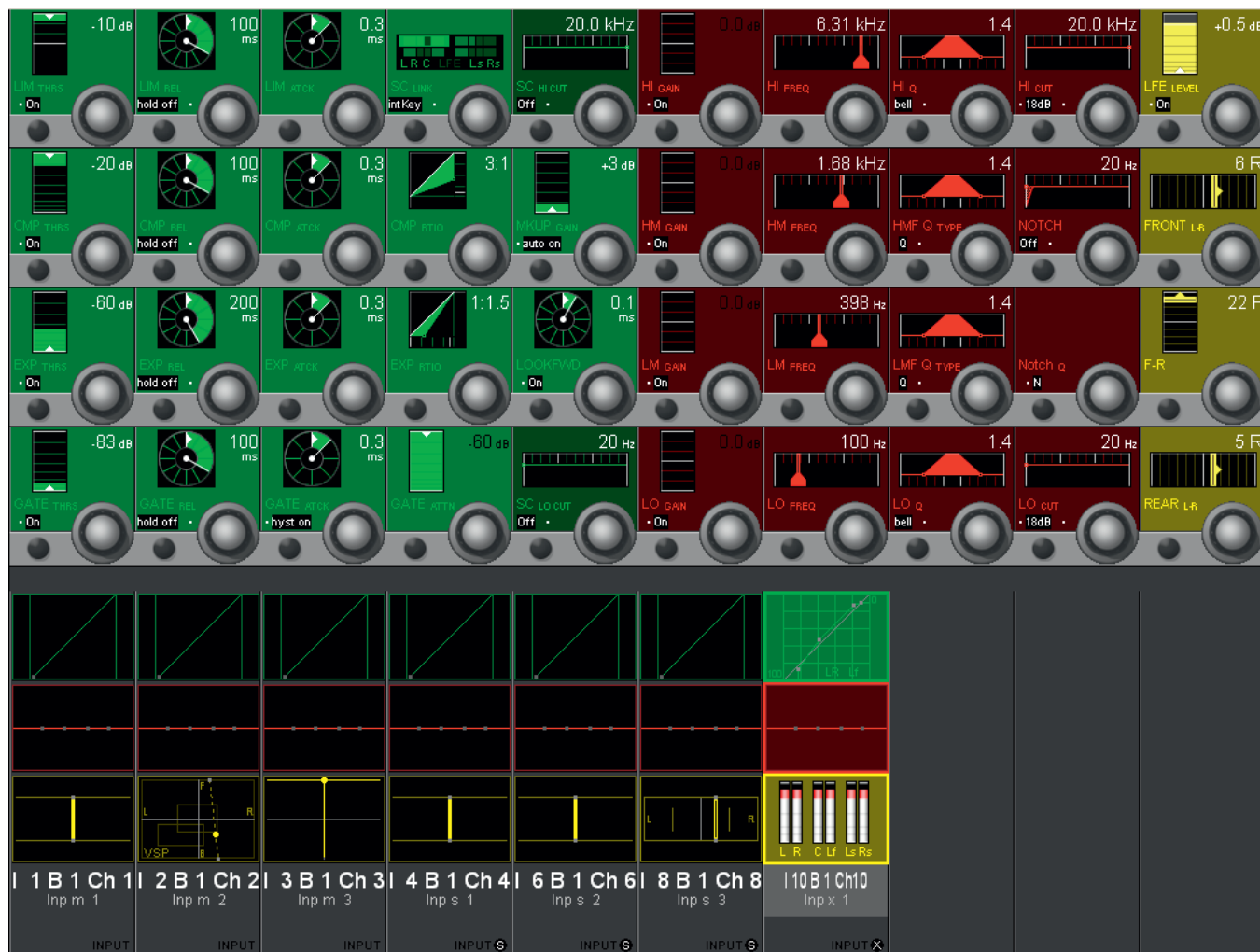

3.4.10 Bus Assignment View

When pressing **VIEW: BUS ASN**, the display changes to the bus assign window of the channel selected with the **LINK / SEL** key.

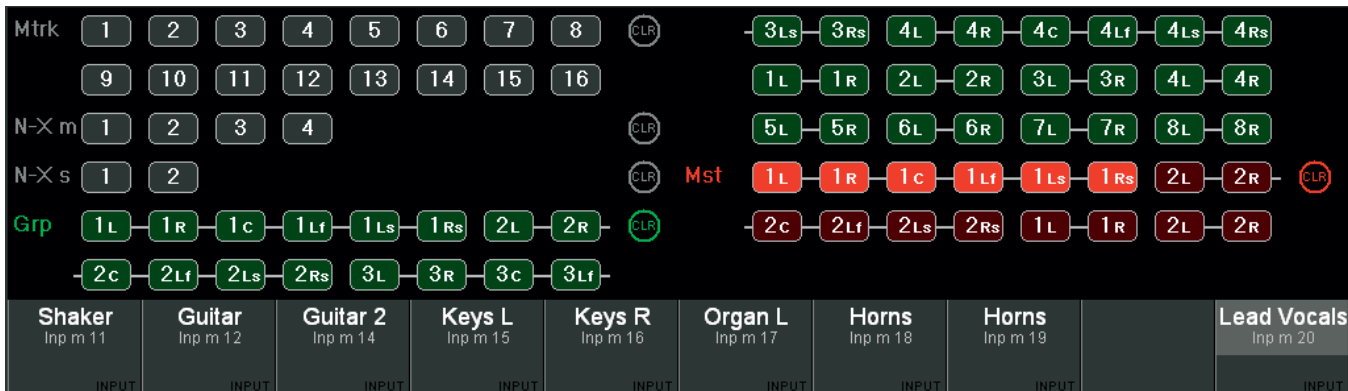

Only busses are shown here to which the current channel can be assigned. Pressing **VIEW: BUS ASN** on a master channel, however, will activate the ‘inverse bus interrogation’ view described below. The CLR buttons will clear the assignment to *all* busses of the corresponding type.

Inverse Bus Interrogation

Pressing **VIEW: BUS ASN** on a group master, an AUX master or a master channel (having a bus routed to its input) opens the Strip Setup dialog on the GC screen, showing the currently assigned channels in magenta color. When pressing **VIEW: BUS ASN** on an N-X owner channel, the inverse bus interrogation is done on the associated N-X bus.

CHAPTER 4

4	Graphical Controller Operation.....	5
4.1	Introduction	5
4.2	The GC Screen.....	6
4.2.1	The View Button	7
4.2.2	The Quick Access Bar.....	7
4.2.3	The Ribbon Style Selector	8
4.3	Graphical Controller Basics.....	9
4.3.1	Sources and Targets.....	9
4.3.2	Pre-defined Configurations	10
4.3.3	Labels	11
4.4	First Level: Main GC Pages	12
4.4.1	Working with Multiple Pages.....	13
4.4.2	The General Patch.....	13
4.4.2.1	General Patch Navigation	15
4.4.2.1.1	Navigating the Sources/Targets List	15
4.4.2.1.2	Other Navigation Methods.....	16
4.4.2.1.3	What Patch Groups are There?.....	17
4.4.2.2	How to Deal with the Analog Interfacing?	18
4.4.2.3	Digital Input/Output Subclasses.....	18
4.4.2.4	Making and Clearing the Cross-Points	19
4.4.2.5	Editing the User Labels in the General Patch	22
4.4.2.5.1	Sorting Options	23
4.4.2.5.2	View the Different Label Types	23
4.4.2.6	Working with Labels	24
4.4.2.6.1	Automatic Label Propagation	25
4.4.2.7	What are Device Labels?	26
4.4.2.8	How to Activate the Device Label Functionality.....	27
4.4.2.9	Where are the Device Labels Saved?.....	27
4.4.2.10	How to Create or Overwrite a Device Label.....	27
4.4.2.11	How to Edit an Existing Device Label.....	27
4.4.2.12	Background Information	27
4.4.2.13	Automatic Generation of Intelligent Fixed Labels.....	28
4.4.3	Channel Patch.....	30
4.4.3.1	Using the Channel Patch for Patching Audio.....	31
4.4.3.2	Setting the Order of DSP Processing Blocks	32
4.4.3.3	On-screen Toggles for Input Selector and Dynamics Key Selector.....	32
4.4.3.4	Editing the Channel User Labels	32
4.4.3.5	Set the Metering and Direct Out Source Point.....	33
4.4.3.6	Switch off the Label Inheritance	33
4.4.3.7	Setup & Activate the Dynamics Sidechain Link.....	34
4.4.3.8	Fader Ramp Control ('Audio Follows Video').....	36
4.4.4	Snapshot Page	37
4.4.4.1	Snapshots	38
4.4.4.2	Multiple Snapshots.....	42
4.4.4.3	Snapshot Crossfading.....	44
4.4.4.4	Additional Snapshot Functionality	45
4.4.4.5	Partial Snapshots	46
4.4.4.6	Typical Applications.....	48
4.4.4.7	Snapshot Filtering (Static Automation).....	49
4.4.4.8	Presets	51

4.4.4.9	Default Settings.....	52
4.4.4.10	Files and Backup.....	52
4.4.5	Cue List / Theatre Cue List.....	53
4.4.5.1	‘Standard’ Cue List.....	53
4.4.5.2	Theatre Cue List.....	56
4.4.5.2.1	Cross-Fading Between Cues.....	57
4.4.5.2.2	Organizing Events.....	58
4.4.5.2.3	Updating Snapshots.....	58
4.4.5.2.4	BlackOut.....	58
4.4.5.2.5	Arm CueList.....	58
4.4.5.2.6	XFade Active.....	59
4.4.5.2.7	Preview.....	59
4.4.5.2.8	MIDI Show Control Device.....	59
4.4.5.2.9	MIDI Port Deactivation.....	59
4.4.5.2.10	Event Types.....	60
4.4.5.2.11	VCA / Channel Mute Mode.....	67
4.4.5.2.12	Isolate Labels and VCA Assignment.....	68
4.4.5.2.13	Mute Groups.....	68
4.4.5.2.14	Hard Mute.....	69
4.4.5.2.15	Cue List Options Menu.....	70
4.4.5.3	Theatre Workflow Tutorial.....	71
4.4.5.3.1	Console Setup.....	72
4.4.5.3.2	Building Cues.....	73
4.4.5.3.3	Rehearsal Phase.....	76
4.4.6	Strip Setup.....	82
4.4.6.1	How to Use the Strip Setup.....	84
4.4.6.1.1	Assigning a Single DSP Channel to a Single Channel Strip.....	84
4.4.6.1.2	Assigning Multiple Channels in one Single Action.....	84
4.4.6.1.3	Moving Already Assigned DSP Channels to Other Channel Strips.....	85
4.4.6.1.4	Useful Information.....	86
4.4.6.1.5	Labels in Strip Setup.....	86
4.4.6.1.6	Metering (the TFT Meterbridge is optional for the 32 fader Vista 1).....	88
4.4.6.1.7	FaderGlow.....	90
4.4.7	Clipboard Libraries.....	91
4.4.7.1	Clipboard Library Window.....	92
4.4.7.2	Paste into Clipboard Library.....	92
4.4.7.3	Copy from Clipboard Library.....	92
4.4.7.4	Rename/Delete a Clipboard Library File.....	93
4.4.7.5	Clear the Display.....	93
4.4.7.6	Update a Clipboard File.....	93
4.4.7.7	Storage Format.....	93
4.4.7.8	Import a Clipboard File from Another Library.....	94
4.4.7.9	Where are Clipboard Libraries Saved?.....	94
4.5	Second Level: The Application Menu.....	95
4.5.1	Titles and Projects.....	95
4.5.2	Save.....	100
4.5.3	Make/Restore Backup.....	100
4.5.4	Import.....	101
4.5.5	Export.....	101
4.5.6	Load DSP Configuration.....	102
4.5.7	Surveyor.....	103
4.5.8	Dynamic-Mode.....	103
4.5.9	Log In (as System Administrator).....	103
4.5.10	About.....	103
4.5.11	Exit Vista Application.....	104
4.6	Third Level: Tools and Settings Ribbon Tabs.....	105

4.6.1	The Tools Ribbon Tab	105
4.6.1.1	General	105
4.6.1.1.1	Clipboard	105
4.6.1.1.2	Follow Solo	105
4.6.1.1.3	Offline Conference	105
4.6.1.1.4	Show Virtual	108
4.6.1.1.5	Machine Control	108
4.6.1.2	Setups	109
4.6.1.2.1	FX Engine	109
4.6.1.2.2	Meter/Generator	109
4.6.1.2.3	Shared Delay	110
4.6.1.2.4	VSP Properties	111
4.6.1.2.5	TC-Reader/Generator	111
4.6.1.2.6	N-1 Assignment	111
4.6.1.3	Signaling	114
4.6.1.3.1	Load Signaling Configuration	119
4.6.1.3.2	Save Signaling Configuration As	120
4.6.1.4	CGM	120
4.6.1.4.1	Control Group Basics	120
4.6.1.4.2	Control Group Setup	121
4.6.1.4.3	Control Group Filter	122
4.6.1.4.4	Control Group Assignment	123
4.6.1.4.5	Hierarchical CGMs	124
4.6.2	The Settings Ribbon Tab	125
4.6.2.1	System	125
4.6.2.1.1	Vista Settings	125
4.6.2.1.2	Downmix Settings	128
4.6.2.1.3	Sampling Rate	128
4.6.2.1.4	EQ/Dyn View	129
4.6.2.1.5	VCA Style Control Groups ('Motors Off')	130
4.6.2.2	Preferences	132
4.6.2.2.1	Load	132
4.6.2.2.2	Save	132
4.7	Fourth Level: SysAdmin functions	133
4.7.1	Tools: Control Group Assign	134
4.7.2	Settings: Show VMC Tree	134
4.7.3	Settings: Meter Source Setup	135
4.7.4	Settings: Ember Control	136
4.7.5	Settings: Reduced Function Set	137
4.7.6	Settings: General Patch Edit	137
4.7.7	Settings: Edit Monitoring Files	141
4.7.8	Settings: Enable Monitoring Setup-Mode	143
4.7.9	Settings: Reinitialize Monitoring	143
4.7.10	Settings : Device Labels (Save and Apply)	144
4.7.11	Settings: Use DeviceLabels	144
4.7.12	Settings: Overwrite Channel User Label	144
4.7.13	Settings: Configure ExternalRouter I/O	144
4.7.14	Settings: Connection Setup	144
4.7.15	Settings: Regenerate Intelligent Fix Labels	144
4.7.16	General Patch: Enable Pro-Bel Setup	145
4.7.17	General Patch: Pro-Bel Setup	145
4.7.17.1	3 rd -Party Control of Console Patch (Native Pro-Bel P-02/08 Support)	145
4.7.17.1.1	Pro-Bel P-08 support	148
4.7.17.1.2	Exclude Certain Patch Targets from Being Changed by Snapshots	149
4.7.17.1.3	Label Import from 3 rd -Party Systems	149
4.7.17.1.4	Support of External Monitoring Source Selector Panels	150

4.7.18	Snapshot: Output Snapshot Isolation	151
4.8	Fifth Level: The Surveyor	152

4 GRAPHICAL CONTROLLER OPERATION

4.1 Introduction

The graphical controller (GC) is an essential part of the Vista system's operation, because it enables the user to utilize all of its enhanced functions, such as the snapshots, book-keeping and much more. It is also the place where the operating software is started and shut down – becoming, in fact, the console's main operations center.

All the operating software – consisting of a large number of individual files needed for proper operation of the console – is saved on the Control PC's hard disk. Even if there are hundreds of configuration, snapshot, and related files saved here from previous Vista sessions, the user basically needs to start only *one* application program: D95ØSYSTEM.EXE.

The D95ØSYSTEM.EXE is represented by the Studer Vista shortcut icon on the GC monitor screen:



The Vista software runs under Windows. All files used by Vista and all files produced by the user (snapshots, mixes, etc.) are fully compatible with the Windows standard. This means that they can be copied to other compatible media, using the Make Backup utility and standard Windows tools and procedures. Long file names (more than eight characters) are supported.

One of the advantages of using standard Windows techniques is that the majority of users will already be familiar with operating a PC-based system. Because all screen and touch pad procedures are derived from the Windows operating systems, please refer to the appropriate manuals if you are not familiar with using them.

Operation of the graphical controller is also fully Windows-compatible. Text strings, files, or even pictures can be copied from one location to the other using the Windows clipboard principle and keyboard shortcuts: **Ctrl + c** will copy to, and **Ctrl + v** will paste from the clipboard. This technique can be used, for example, to enter repetitive labels into the user labels, or for copying mixes from one title to another.

Full use is made of the Windows-standard, context-sensitive menus that can be accessed by the right touch pad button. The same is valid for conventional double-click techniques. The **Tab**, **PgUp/Dn**, and **arrow** keys behave according to standard Windows operation.

The graphical controller's screen colors, screen sizes, individual window positions and sizes, certain font sizes etc., are also part of the Windows Screen Properties, and can be adjusted there.

Because the graphical controller's user interface can be configured to suit the individual needs of specific users, all the graphics shown in this operating instructions manual may differ slightly from what you will see on the GC display of *your* Vista digital console.

4.2 The GC Screen

Upon starting the GC for the first time, the screen will look similar to this:

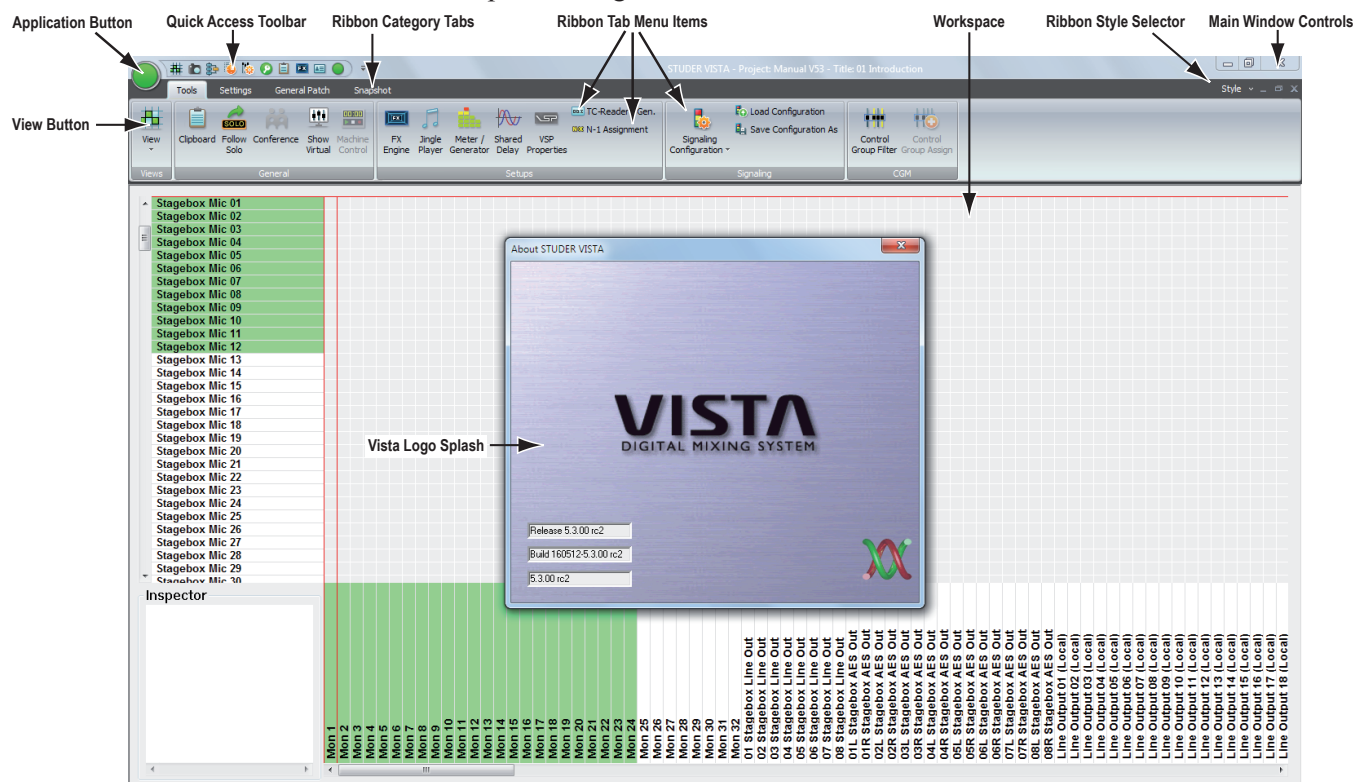

Please note the most important parts of the screen:

- The **Application Button**, allowing access to most of the Vista system's bookkeeping functions. Refer to [chapter 4.5](#);
- The **View Button**, containing various short-cut icons to navigate to the most important pages;
- The **Quick Access Toolbar**, a mini-toolbar that can be customized to contain frequently used menu items, independent of the currently selected view;
- The **Ribbon Category Tabs**, are containing menu items belonging to the tab's category. The category tab is automatically selected if the view is changed by using the view button;
- The **Ribbon Tab Menu Items**, displaying the necessary menu items that are matching the currently selected view;
- The **Workspace**, where you will open the Main GC pages and do other useful things;
- The **Ribbon Style Selector**, allows to choose the ribbon color style;
- The **Main Window Controls** (*minimize, maximize/window mode, quit*);
- The **Vista Logo Splash**, which will disappear a few seconds after the start.

4.2.1 The View Button

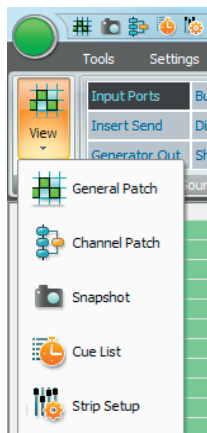

When clicking on the View button, the icons of the five main GC pages appear in a drop-down list.

Choosing the desired GC page not only opens this page, but also changes the Ribbon tab to the category that contains the menu items for this GC page.

Once the desired page is open, the page's icon is displayed in the View button area.

4.2.2 The Quick Access Bar

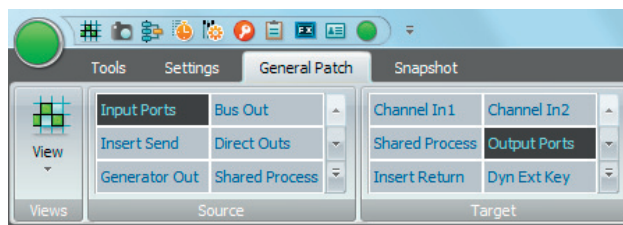

The *Quick Access Toolbar* is normally shown on top of the Ribbon menu. When clicking the customize button on the very right of the *Quick Access Toolbar*, a menu appears. Firstly, it provides a tick-list of all currently shown quick access menu items.

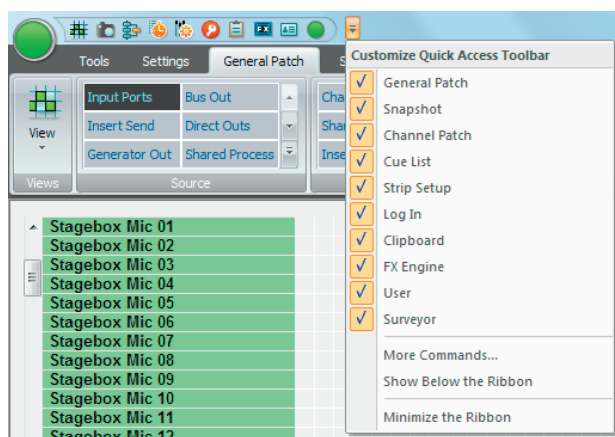

More Commands ...:

Secondly, three more functions can be chosen :

This function brings up the detailed configuration window where access to all menu items of all categories is provided. To do so, under <choose commands from > the category tab can be selected. Then, a list of all menu items of this category is given :

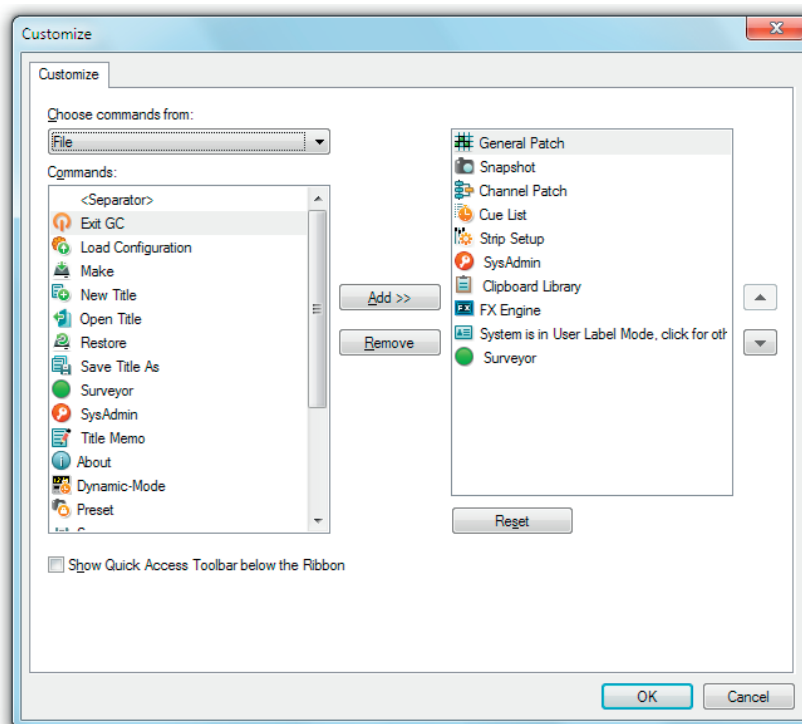

By choosing the desired menu item (also called 'Commands') and clicking on the Add button will add that specific menu item to the *Quick Access Toolbar*. The Reset button will bring you back to the state that the *Quick Access Toolbar* had before you started to modify it.

Show Below the Ribbon:

Selecting this function allows to place the *Quick Access Toolbar* underneath the Ribbon menu instead of above the Ribbon menu. Please note that this takes away some of the space which used to display the selected View Page.

Minimize The Ribbon:

This basically hides all menu items and only shows the *Ribbon Category Tabs*. More space is provided for the View Page :

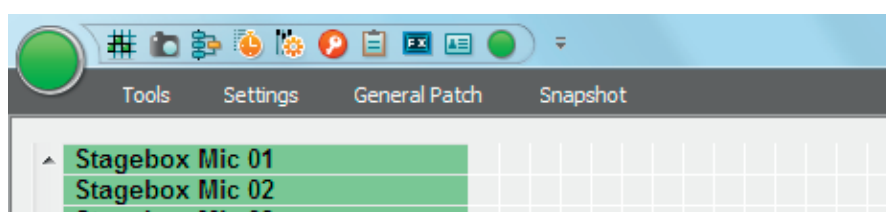

Please note that also doubleclicking on the *Category Tabs* toggles between minimized Ribbon and normal Ribbon View.

4.2.3 The Ribbon Style Selector

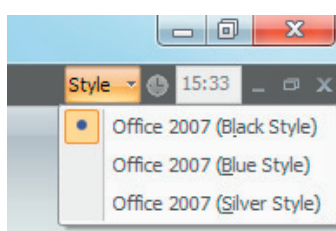

Here, the choice from three different window color-styles is possible. Please choose to suit your personal taste.

4.3 Graphical Controller Basics

This chapter describes the basic concepts of the work with the graphical controller (GC).

4.3.1 Sources and Targets

Generally, all audio signals available to the Vista can be divided into *Sources* and *Targets*. These names are used rather than ‘Input’, ‘Output’, etc., in order to avoid any confusion about where the audio signal comes from and goes to.

- Sources:** A *Source* is anything that delivers an audio signal:
- *Digital Input Interface* (e.g. AES/EBU or MADI);
 - *Analog Input Interface* (e.g. HQ mic/line input);
 - *Channel Output* (for example, direct output of input channel #24, master output, etc.);
 - *Channel Insert Send*;
 - *Bus Output* (unlike with analog consoles, any bus is a valid audio signal source within Vista; for example, AUX Mono Bus 12 can be used to feed an output interface, or to become the source to an input channel);
 - *Test Generator*.

- Targets:** A *Target* is anything that can receive one (mono or stereo) audio signal:
- *Channel Input 1* (first audio input to a channel; free for all input channels. It is used to connect Sources to input/track monitor channels, such as a MADI output from a digital multi-track to a track monitor channel, or the corresponding bus to an output channel, such as a Group, Master, or AUX channel);
 - *Channel Input 2* (second audio input to a channel; free for all channels);
 - *Channel Input 3* (third audio input to a channel; used for the test generator connection per default, can be re-patched to any source at any time),
 - *Channel insert returns*;
 - *Digital output interfaces* (e.g. AES/EBU or MADI);
 - *Analog output interfaces*.

Sources and Targets implicitly behave as mono or stereo, depending on their character. A *stereo* Source or Target can be treated, nevertheless, as consisting of two *mono* parts. Any Source can be connected to as many Targets as needed via the General Patch page. However, a Target (stereo or mono) can have only one Source (stereo or mono) assigned to its input.

4.3.2 Pre-defined Configurations

	Vista 1 offers five different configurations to select from:
Vista 1 Mono	Has a large number of mono inputs that can be mixed to two stereo masters.
Vista 1 Stereo	Comes with a good blend of necessary channels for a stereo production. Mono groups and stereo masters are provided, as well as mix-minus busses.
Vista 1 Surround	Features the necessary channels for a surround production. Groups and masters are in 5.1 surround, mix-minus busses are provided as well. Four automatic surround-to-stereo and -mono downmixers are available.
Vista 1 FOH	Offers a large number of input channels combined with mono and stereo masters.
Vista 1 Monitor	Provides a large number of mono as well as stereo AUX busses, all of them with graphic EQ.

For more details about these configurations please refer to [chapter 6](#).

4.3.3 Labels

Labels are used extensively within the system to define objects, such as audio sources, channel names, etc., and to visualize these objects in various windows within the GC.

Please note that all labels are saved within snapshots and presets, together with all audio settings.

There are various ways to work with labels within the system. For a description of how to use labels, refer to [chapter 4.4.2.6](#). Basic label types are described below:

Fixed Labels These are generated automatically at the time of system configuration, and are used to identify *hardware-oriented* objects. For example:

Fixed Label	Meaning
AES In 4L (Local)	AES/EBU, physical input no. 4, left channel, on internal ('local') AES/EBU I/O module
Line Output 07 (Local)	Line, physical output no. 7, on internal ('local') analog line output module

Fixed labels cannot be modified by standard user, only the system administrator is allowed to do so. *However this is not recommended.*

User Labels These by default are identical to the fixed labels when starting a new title using one of the pre-configured templates. The user is allowed to rename these User labels in the GC to make the system environment more user-friendly. User labels are used to give the objects a useful, *application-oriented* name. For example:

Fixed Label	User Label	Meaning
AES In 4L (Local)	DAT 1	DAT Player 1, coming in via AES/EBU, physical input no. 4, left channel, on internal ('local') AES/EBU I/O module
Line Output 07 (Local)	Foldback 1	Line, physical output no. 7, on internal ('local') analog line output module, is the foldback Send 1 to the Studio Floor

Inherited (or Device) Labels Inherited labels are used primarily to identify the *Source Signal* that is connected to the Channel Strip, rather than the user label of the Channel. In this way, as soon as the signal is connected to a channel's input, the channel strip display inherits the Label from the actual Source.

4.4 First Level: Main GC Pages

There are five main graphical controller pages, each of which deals with a different operating part of the Vista system:

- General Patch page
- Channel Patch page
- Snapshot page
- Cue List page
- Strip Setup page

These main pages can be accessed in three different ways:

- From the View button, by clicking on the appropriate icon:

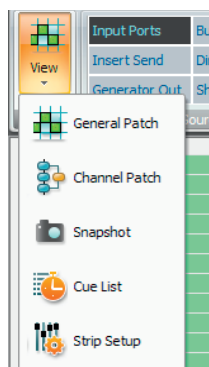

- Using the *Quick Access Toolbar* icons, by clicking on the appropriate icon in the *Quick Access Toolbar*, or
- Using the function keys in the desks control bay above the trackpad – which is probably the fastest way:

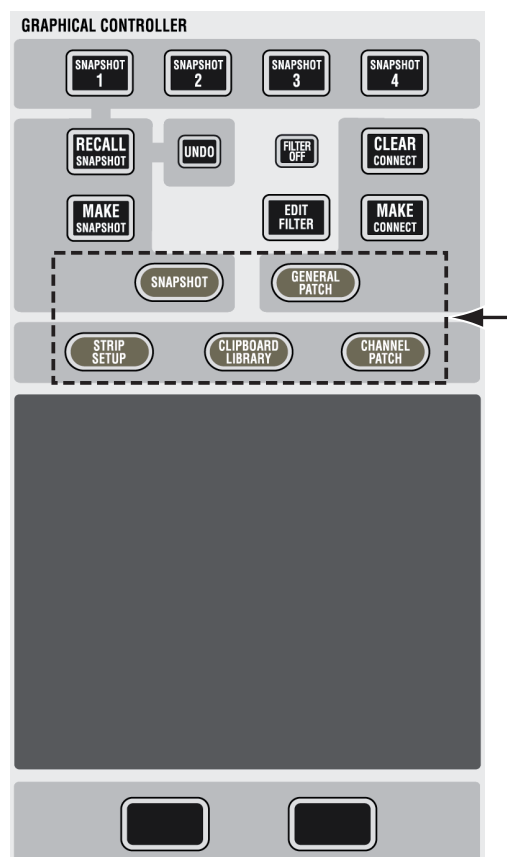

4.4.1 Working with Multiple Pages

Working with multiple pages is not possible with the new Ribbon style menu

4.4.2 The General Patch

The GC General Patch page can be accessed in three different ways:

- From the **View** button, by clicking on the appropriate icon
- Using the *Quick Access Toolbar* icons, by clicking on the appropriate icon
- Using the **GENERAL PATCH** function key. This is the fastest way.

The General Patch is the main tool used to establish and clear audio connections within the system. The name 'Patch' is used because it mimics the conventional patch bay used in analog consoles. It accomplishes all the tasks of a conventional patch bay, and much more. Patch cross-points are saved into the snapshot/preset memories.

It utilizes an X-Y axis (or side-to-side/up-down) representation to aid viewing and editing of existing connections or cross-points (equivalent to the location of patch cords), and all existing Sources and Targets (equivalent to the patch-jack pairs used in most patch bays).

The General Patch can be thought of as a number of 'sub-patches' whereby either single groups of the sources and targets can be viewed at a time, or any predefined combination of sources and targets by using the *User Patch Groups*.

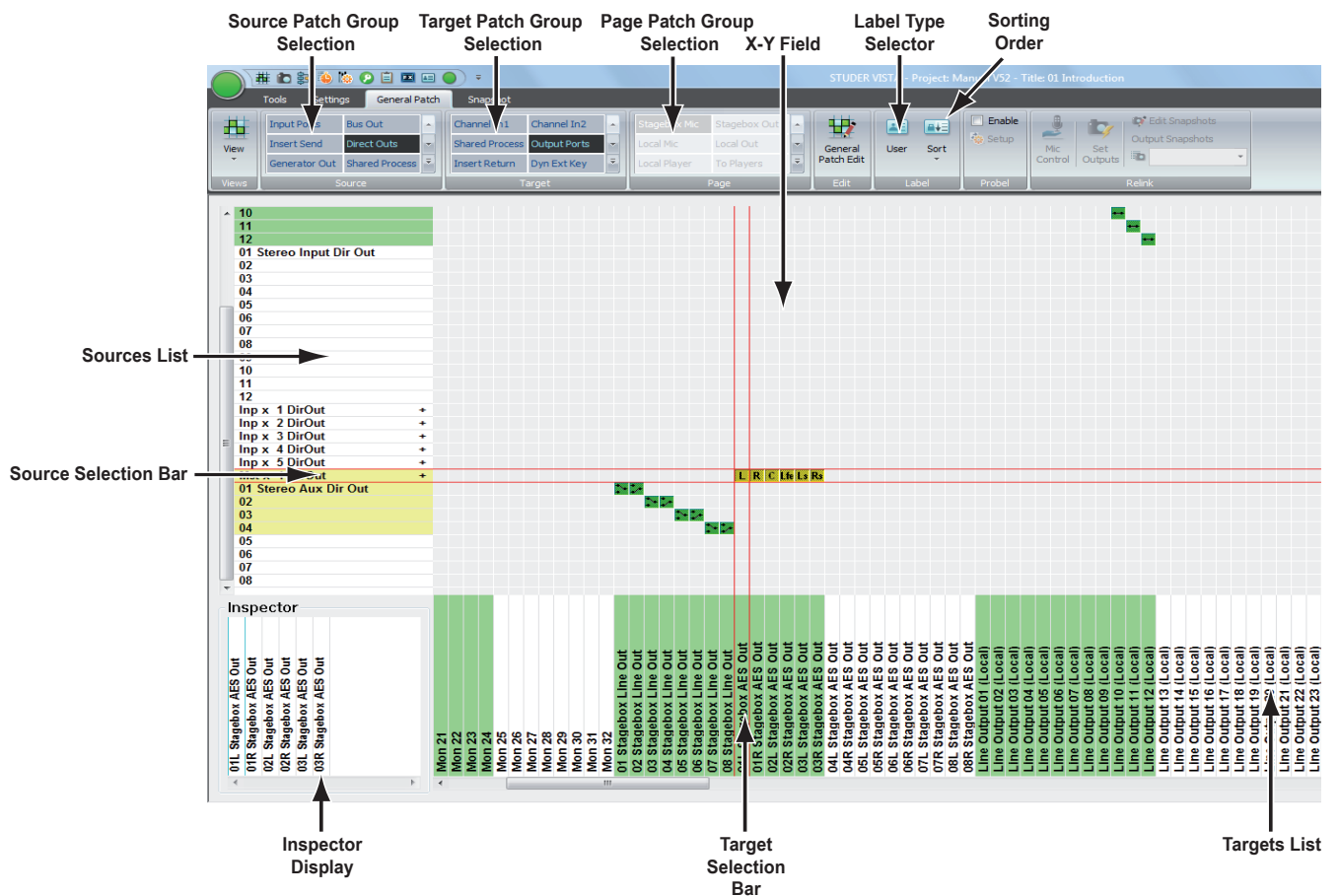

The General Patch consists of:

- A Targets list (the lower horizontal, or x axis), equivalent to the lower jack row in a patch bay
- A Sources list (the left-hand vertical or y axis), equivalent to the upper jack row in a patch bay
- The X-Y field, where the cross-point icons enable interrogation and editing of cross-point connections
- The Source- and Target Patch Group selection
- The Page Patch Group selection (navigates both, Source- and Target lists)
- The Source- and Target selection bar, which allows choosing a crosspoint
- Viewing selections which allow sorting of the Sources and Targets Lists by label type
- The Fixed/User Label displays for the selected Source/Target
- The Inspector Display.

4.4.2.1 General Patch Navigation

4.4.2.1.1 Navigating the Sources/Targets List

The audio sources list (located on the Y axis) and the targets list (on the X axis) allow the user to find and select a Source/Target pair, and to make or clear a required cross-point connection.

There are different ways to navigate and select the required source and target for making or clearing patch connections. The simplest process to select the required Source/Target selection is described below:

- 1 Select the Patch Group of the required source/target using the Source- and Target Patch Group selector. This will show in the X-Y axis list all the possible sources/targets available in the configuration currently loaded. Scrolling using the standard windows scroll bar may be required to see all the sources/targets from the chosen Patch Group. Select the required Source/Target by clicking on the Source/Target name or by using the keyboard cursor arrows to move up and down the list. This will position the Selection bars of the X-Y axis to the chosen Source/Target. The intersection of the two Selection bars will allow the making or clearing of a cross-point based on the chosen Source and Target (see chapter 4.4.2.4 for information on how to make or clear cross-point connections).

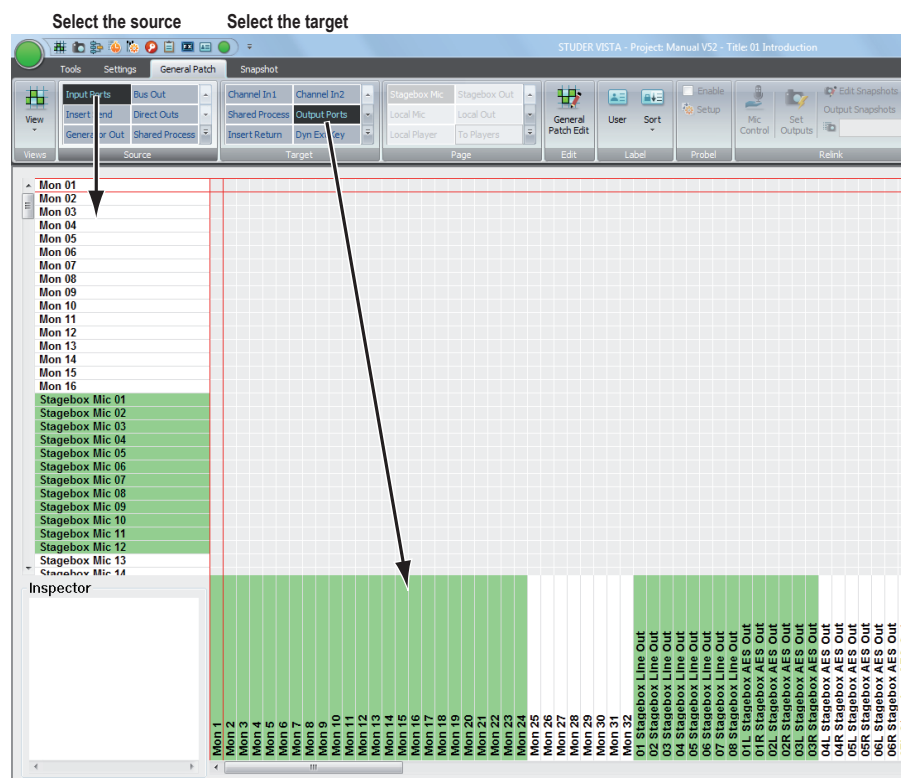

- 2 Select the required Page Patch Group in the Page Patch Group selector. This will show the X- and Y axis of the predefined Patch Group at once. Proceed as described above to select source and target.

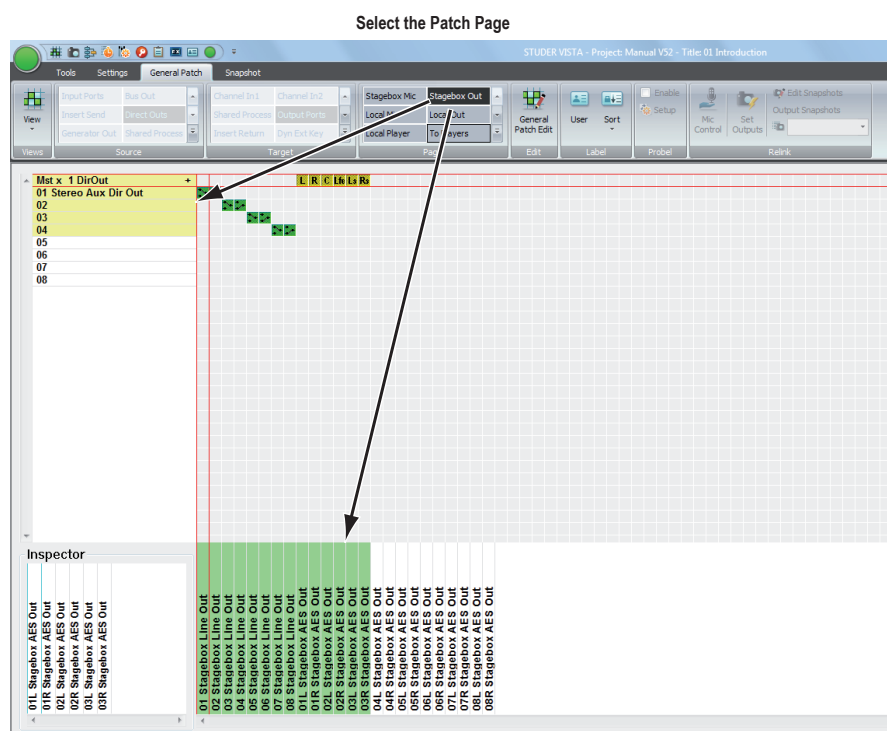

4.4.2.1.2 Other Navigation Methods

Using of Color for Navigation:

Color is used in the Sources and Targets lists to give a clear indication and overview of the sources and targets which have connections patched. If a Source is connected to a Target or multiple targets, the Source label in the Sources List will be highlighted by a color. Similarly, if a target is connected to a Source or a number of different Sources, then the Target label in the Targets List will be highlighted by a color. The meaning of the colors is as follows:



A single connection is made to the indicated Source or Target.

Two or more connections are made to the indicated Source or Target.

The Target has a protected connection.

If a Source or Target is highlighted (indicating a connection has been made to it), double-clicking on the label in the Sources/Targets Lists will navigate directly to the cross-point so that the Source Selection bar and Target Selection bar intersect at that cross-point. This is an extremely fast method to find what is connected to a Source or Target without the need for scrolling or manual searching of the sub patches. If a Source or Target is highlighted in Yellow (indicating two or more connections are made to it), double-clicking on the label in the Sources/Targets Lists will navigate directly to the first cross-point. Subsequent double-clicks will navigate to each of the following connections that are made to the Source/Target in question. If all connections have been shown, a further double-click will return the user to the first connection and loop around the connections once again with further double-clicks.

4.4.2.1.3 What Patch Groups are There?

There are different, fixed Patch Groups for each of the Sources and Targets Patch Group selectors :

Sources:

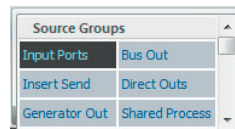

Targets:

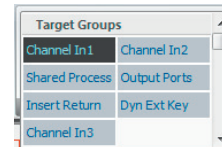

Each Patch Group contains a number of Sources or Targets, depending on the currently loaded configuration. Sometimes certain sections will not be present; for example, if no Channel Inserts have been configured, there will be no Insert Send section within the Sources List, and no Insert Return section within the Targets List.

The size of the X-Y General Patch automatically adapts to the number of channels, input interfaces, output interfaces, and to the presence of DSP function blocks in the channels – as defined in the currently loaded configuration.

Some detail information on the sections:

Source Patch Groups:

Dir Out	All Direct Outputs of all channel types.
Input Ports	All input audio interfaces (AES/EBU, MADI, or D21m A/D converters).
Insert Send	Sends from the inserts of all channel types.
Bus Out	Unlike analog consoles, with the Vista any bus is a valid audio signal source; e.g. an AUX mono bus can be used to feed an output interface, or to become an input to an input channel.
Generator	The test generator's signal.
Shared Process	All outputs of the shared process DSP section, such as CR/ST monitoring, downmixers, shared delays, etc.
Effect Out	The output signals from the FX engines.

Targets Patch Groups:

Channel In1	First audio input to all channel types, <ul style="list-style-type: none"> • Free to use for all input channels, • Used for default connection of the corresponding Bus for an output channel, such as a Group, Master, or Aux channel.
Channel In2	Second audio input to all channel types, <ul style="list-style-type: none"> • Free for all input and output channels.
Channel In3	Third audio input to all channel types, <ul style="list-style-type: none"> • Used for the Test Generator connection per default, • Can be re-patched to any source at any time.
Output Ports	All output audio interfaces (AES/EBU or MADI, D/A converters).
Insert Returns	Returns to the inserts of all channel types.
Dyn Ext Key	Input for the external control signal (key) to the Dynamics Sidechain of all channel types.
Shared Process	All inputs to the shared process DSP section, such as CR/ST monitoring, downmixers, shared delays, etc.
Effect In	Inputs to the FX engines.

4.4.2.2 How to Deal with the Analog Interfacing?

There is no difference between analog and digital interfacing. The respective HQ mic/line input card or line output card incorporates the A/D or D/A converters and provides digital signals to- and from the system.

4.4.2.3 Digital Input/Output Subclasses

Subclasses are not used with the new General Patch page anymore.

4.4.2.4 Making and Clearing the Cross-Points

The creation and updating of cross-points is simple. First, select the source and target; the selection bars have to be crossed to form an X-Y pair.

There are two ways of making or breaking a cross-point connection:

- By double-clicking the left touch pad button, while the cursor is positioned over the crossed Selection bars, or
- Using the **CLEAR** and **MAKE** function keys in the desks control bay:

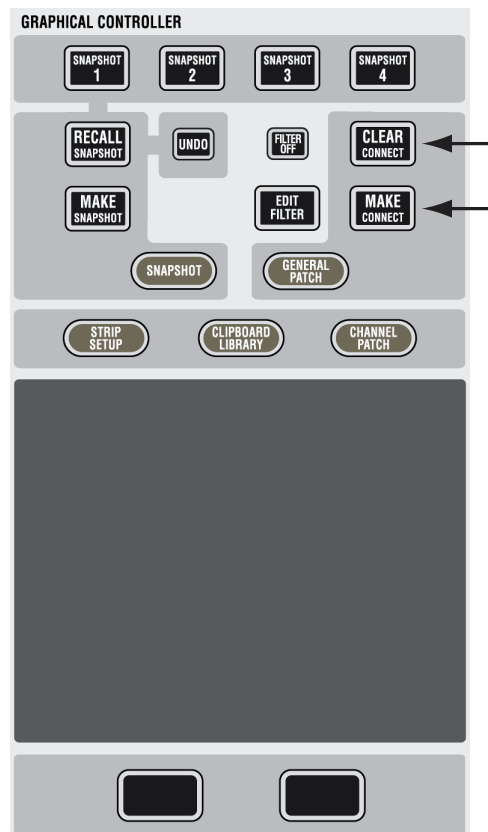

Using the **MAKE CONNECT** (make connection) function key will always make a default connection, depending on the Source- and Target-type combination. Using the **CLEAR CONNECT** (clear connection) function key will always clear any cross-point connection. (This is the *fastest* method to make or clear a connection.)

Double-clicking the left touch pad button: This method is more sophisticated, because it allows you to select from a *number* of connection options displayed in a pop-up menu box. The menu display depends upon the combination of Source (mono or stereo) and Target (mono or stereo). The uppermost connection type in the menu is the default connection type, which is applied if you use the function keys, as shown above.

Mono Source – Mono Target

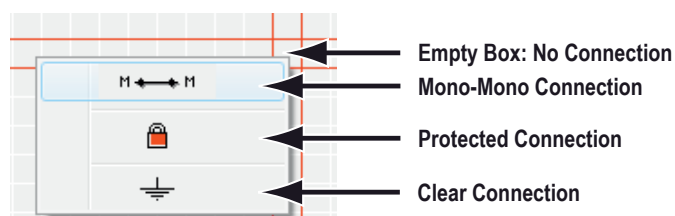

Stereo Source – Mono Target

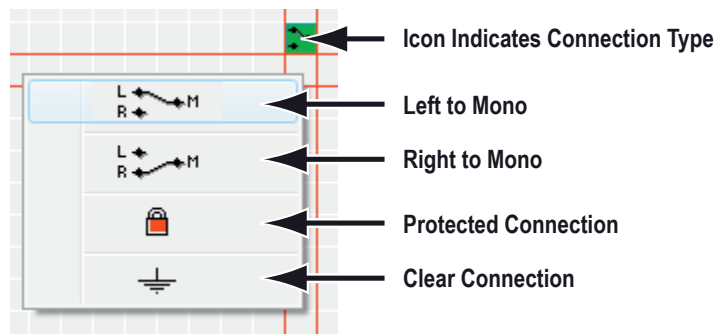

Mono Source – Stereo Target

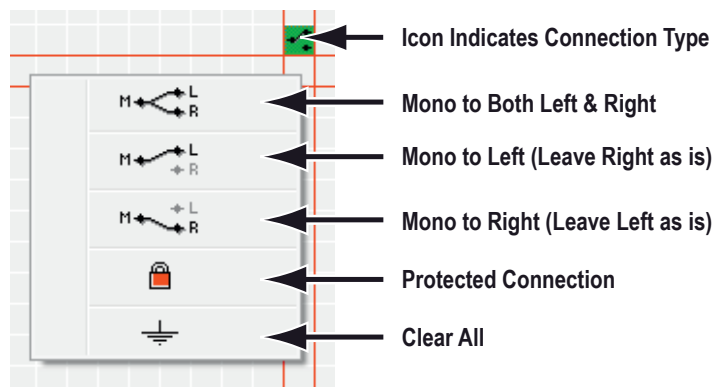

Stereo Source – Stereo Target

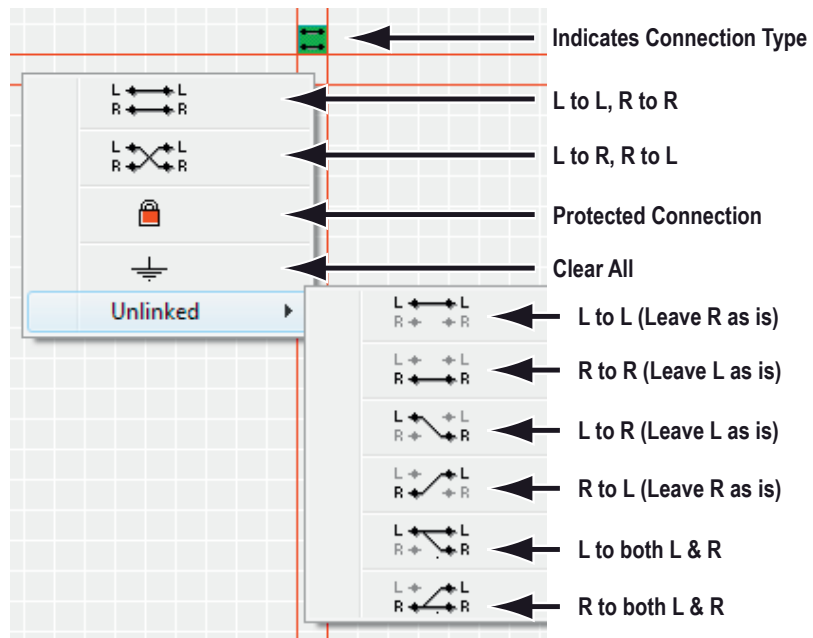

The last menu allows *unlinked* operation, a phrase that refers to a Stereo Target being unlinked and its left and right components used with *different* Sources. Such cross-point connections enable one Target to be connected with *two* Sources, and are indicated with a *yellow icon*.

Tip A feature is available for fast diagonal patching of multiple Sources to multiple Targets. The example below shows this feature used in practice.

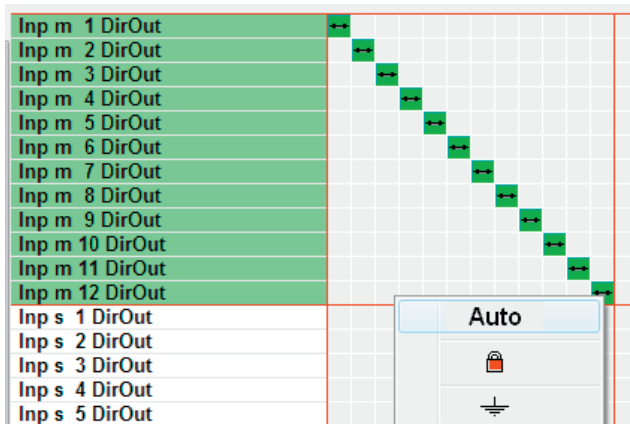

- By keeping the left touch pad button pressed while dragging the pointer across a region in the General Patch view, multiple connections can be selected now.
- While the left touch pad button is still pressed, a right-click opens a selection window; when **Auto** is selected, any desired number of patch points can be connected at the same time.

In the same way, multiple patch points also may be locked, unlocked or cleared in one go.

- A double-click on a patch point allows either connecting or disconnecting this patch point immediately.

Patching Surround Sources

A surround source can very easily be patched to a 5.1 input channel by using the 'auto' patch facility, where all six discrete mono sources are patched at once and with one single click. Moreover, there is a '+' unfold icon with every 5.1 target. When clicking on it, all 6 individual legs of the surround target are shown and can be patched in any desired order. Clicking on '-' closes this view to show only one single patch connection again.

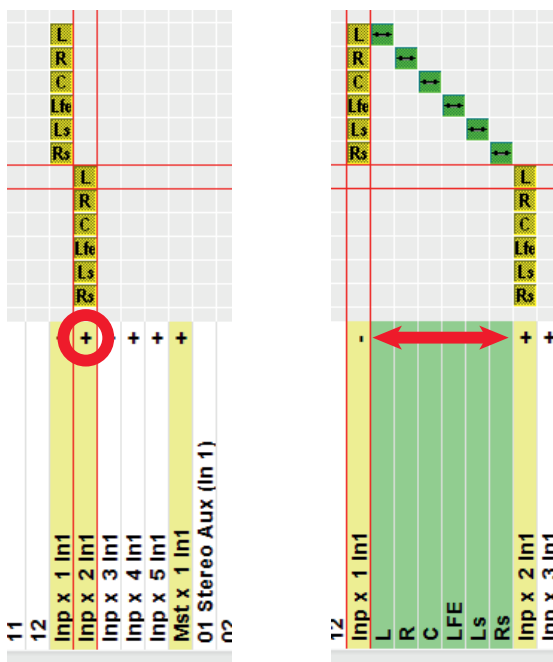

Connection Protection

It is also possible to protect a certain connection from accidental change both by the user or by recalling a snapshot.

Double-clicking on a connection selects the padlock item to lock the connection. To unlock, double-click again.

Both the background of the Target as well as the connection become red. When attempting to change a protected connection, a warning appears, together with the instructions on how to unprotect the connection.

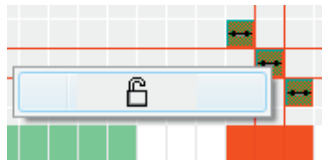

4.4.2.5 Editing the User Labels in the General Patch

In order to edit the user labels in the General Patch view, right-click on the desired Source or Target in the Sources/Targets list.

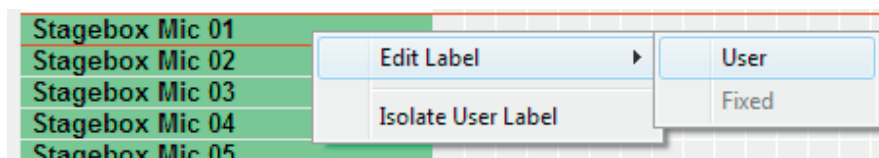

Click on the Edit Label field of the Source or Target and select the User label. This will open a dialog box that allows editing a user label, such as changing it from 'Stagebox Mic 01' to 'Snare':

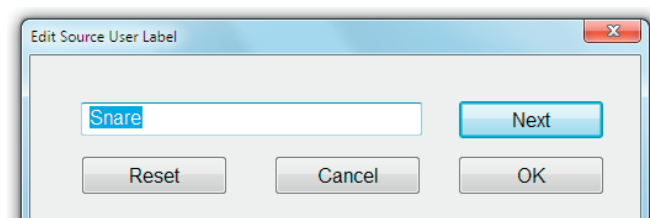

To automatically move to the next Source/Target in the list, either click on 'Next' or hit **ENTER** on the keyboard. To close the dialog box click on 'OK'. It is possible to choose a Source/Target from the General Patch list without closing the Edit User Label dialog box. Simply click on the desired Source/Target from the General Patch list with the window still open. This will automatically enter it into the window for editing.

A click on 'Reset' will restore the 'Inp m 1 In1' default user label.

User Labels with up to 13 characters (depending on the width of the individual characters) can be used for Input sources. These User Labels can then also be shown in the Vistonics area of each channel strip.

4.4.2.5.1 **Sorting Options**

There are two options for sorting the display of the Sources and Targets in the General Patch Lists. This sorting is independent of which label type is being displayed due to the global label mode selection.

Sort by Fixed Label: Independent of the User Label, the Sources and Targets will be sorted and displayed in alphabetical order, depending on the fixed label of the Sources/Targets.

Sort by User Label: The Sources and Targets will be sorted and displayed in alphabetical order, depending on the User Labels of the Sources/Targets.

To select the sorting method, choose the ‘fixed label’ or ‘user label’ option button as shown below:

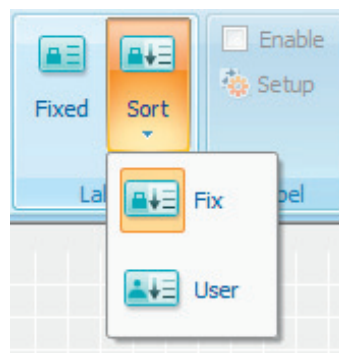

Tip The most useful sorting method is to sort by ‘fixed label’.

4.4.2.5.2 **View the Different Label Types**

It is typical that a user will work in a single mode of label type display within the GC. There are times, however, when it is useful to temporarily display another of the label types globally within the GC to help with patching. The Label mode is changed by clicking on the ‘Label’ button in the system toolbar:

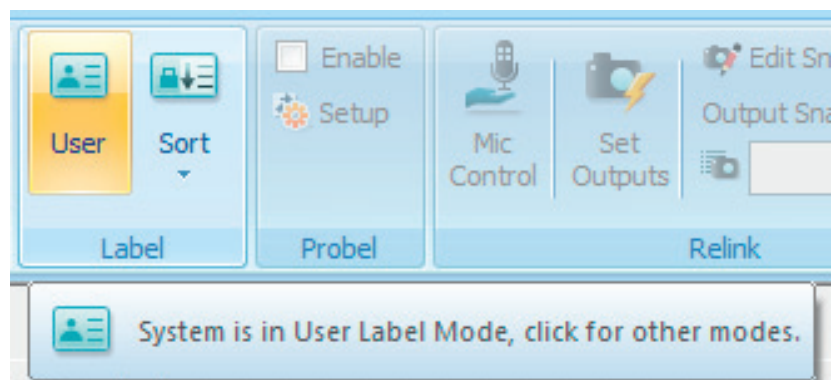

Clicking this button will toggle the label view globally throughout all parts of the GC. The label display can be toggled between FIXED, USER and Inh /Dev (Inherited/Device). For a detailed description of how to work best with labels, see below.

4.4.2.6 Working with Labels

For a detailed description of different label types, please refer to [chapter 4.3.3](#).

The most important aspect of any audio patching system is its labeling. Clear labeling allows fast navigation and fault-free patching.

Labels exist within the general patch window as well as within each single channel. Depending on your preferred way of working, some of the label fields may be filled in automatically by the system (by setting some options), or you choose to type the labels manually in all the places. Two principal automatisms for automatically copying labels exist within your system:

- 1 Your studio device names (devices connected to a specific console input) may be filled in automatically into the General Patch window after you made a new title, or recalled a snapshot or preset. These labels are then read from a file saved centrally. So you can change your studio wiring, only having to update one file, and then seeing your updated wiring even when opening former projects.
- 2 The labels within your channels may be filled with the names of connected sources, copying labels from the source to the channel whenever a patch point is set, cleared, or changed.

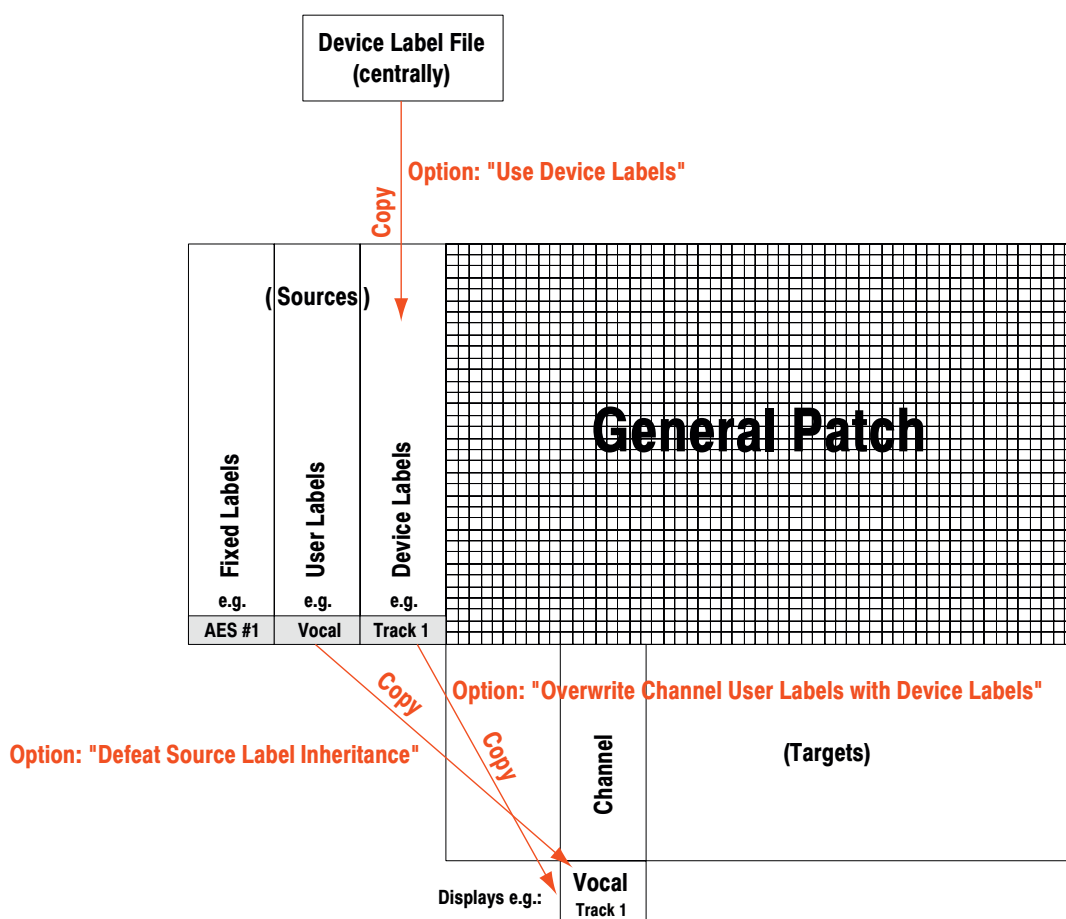

Note: The 'Defeat Source Label Inheritance' option is normally not activated. The other two options may vary, depending on your preferred way of working. In principle, you can select to work according to one of the two methods described below.

4.4.2.6.1 Automatic Label Propagation

The philosophy on Vista consoles concerning labeling is not to name any labels *within channels*, but to name *patch sources* in the General Patch, letting the system propagate them to the connected channels. Specifically, we are talking about two kinds of labels which will be propagated in this way: Device labels (technical labels), and User labels (session labels, e.g. track sheet). This also supports the workflow, whereby the operator first names his sources and then patches them to any possible channel.

Advantages: If a source is connected to more than one channel, or if a patch is changed, the labels are correctly updated on the actually patched channels. You see what you hear!

Change View by Clicking on Label Type Button in the GC's Toolbar

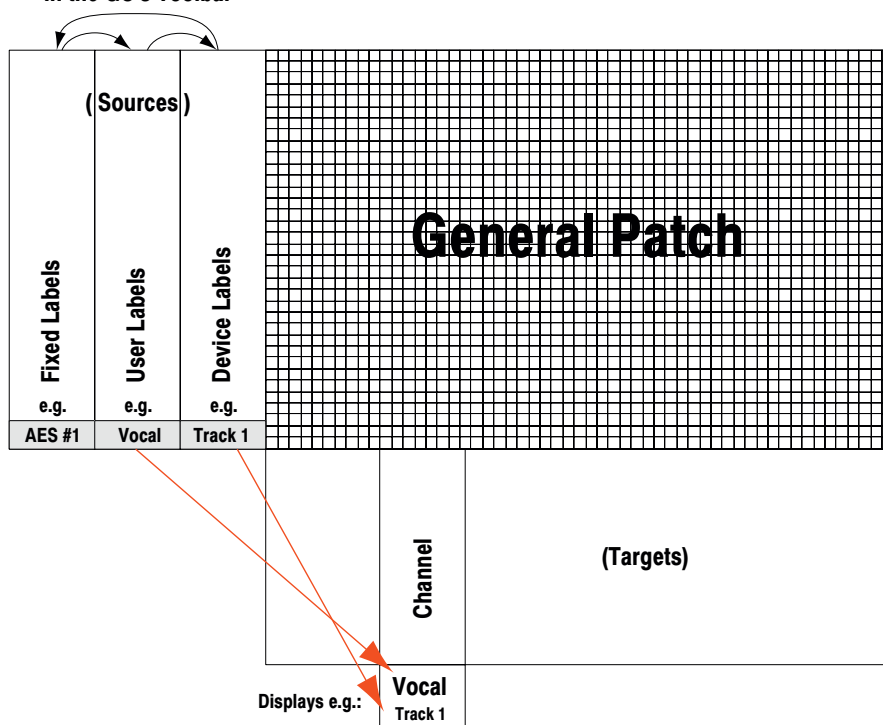

How to Proceed:

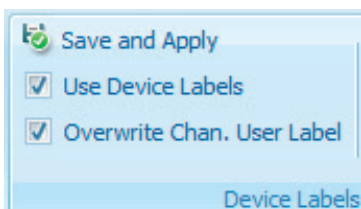

- Switch *on* the 'Use Device Labels' option in the Settings/Device Labels menu. (Whilst being logged in as Sysadmin)
- Switch *on* the 'Overwrite Chan. User label with Device Label' option in the Settings/Device Labels menu.
- There must be a file '__DeviceLabels.pre' present, which holds your device labels (technical labels), e.g. 'Studio 1', 'Mic 1').
- Type your track sheet as User Labels of Input Ports into the Source List of the General Patch.
- Patch Sources to Channels, and you will see session labels displayed in the top line of each channel. You may have to press the **GLOBAL VIEW: LABEL TYPE** key until you see the device labels or the fixed channel labels in the second line.

This may look as follows:

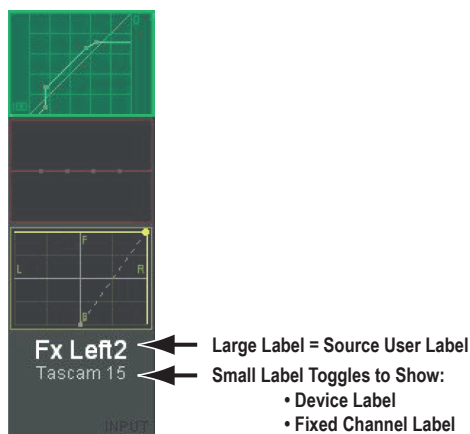

Note In the Strip Setup window it is possible to display either the session labels (standard) or the device labels, depending on the option selected in the lower right corner of the window.

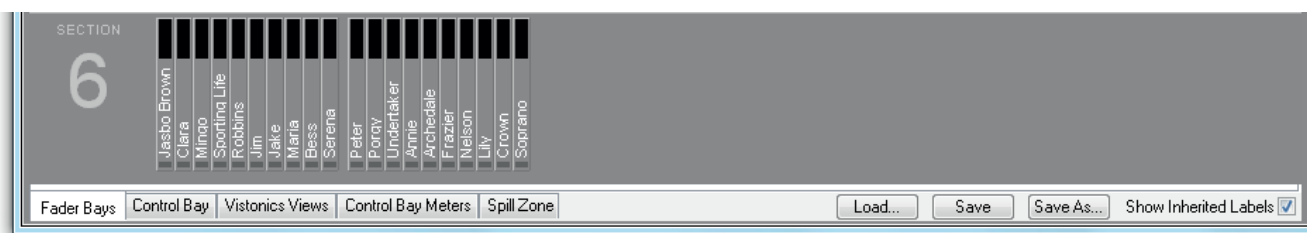

4.4.2.7 What are Device Labels?

All labels shown in the general patch and within the channel strips are always saved together with all audio settings within snapshots and presets. Some of the labels you will name in the patch will most likely represent your studio environment and where your equipment is connected to the console. E.g. you might possibly want to label the AES/EBU input 30 as 'Tascam 11', in order to recognize that you have connected your recorder that way. Since these labels are contained within each snapshot or preset, it is theoretically also possible to change the labels just by recalling a snapshot. In some cases this may be very useful (e.g. if you have entered a track sheet, but would like to use a different one for your next song), but in some cases this can be a handicap: E.g. you change your studio wiring slightly, e.g. add new equipment, but still want to use some of your older project settings. This would lead to the fact that you would have to update all the old snapshots and presets. The same handicap applies if you start with a new title. You will most likely want to see your equipment names appear in the patch automatically. This is where the device label functionality comes up. We have one file holding your device labels (such as 'Tascam 11' for the AES/EBU input 30), and the system is able to automatically read these labels from that file and apply it to your current General Patch screen.

4.4.2.8 How to Activate the Device Label Functionality

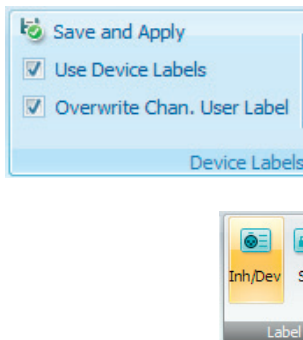

In order to activate the automatic import of your device labels from the device label file, two conditions must be met:

- There must be a preset file named ‘`__DeviceLabels.pre`’ matching the currently loaded configuration and holding your device label names.
- The ‘User Device Labels’ option in the SysAdmin/Device Labels menu must be activated.

This will automatically show the device labels in the General Patch window when switching to the corresponding label mode.

4.4.2.9 Where are the Device Labels Saved?

As you know, these labels are normally not changed for a specific session, but will stay constant in a studio installation. This is why they are saved in a preset (*.pre) file, being valid for the currently loaded configuration, rather than just a snapshot or title. If a different configuration is loaded, you will need to import the ‘`__DeviceLabels.pre`’ file from the previous configuration.

4.4.2.10 How to Create or Overwrite a Device Label

If you create a device label file from scratch or overwrite an existing one with a new one, you may proceed as follows:

- Enter the device labels into the USER LABEL field of the patch (input ports and output ports). *Do this in the USER LABEL field.*
- Enter SysAdmin mode in the GC by clicking the padlock icon on the toolbar, and enter the system password.
- Go to the SysAdmin/Device Labels menu and select ‘Save and Apply User Labels as Device Labels’.

4.4.2.11 How to Edit an Existing Device Label

Since the device labels are saved in a regular preset file, you just log in as the system administrator and recall the ‘`__DeviceLabels.pre`’ file. You will see the device labels again in the patch (USER LABEL field). Now you may edit them; then either click UPDATE, or go to the SysAdmin / Device Labels / ‘Save and Apply User Labels as Device Labels’ menu.

4.4.2.12 Background Information

If you are using the device label functionality (option Settings/Device Labels/Use Device Labels), you activate an automatic and repetitive import of these labels from the ‘`__DeviceLabels.pre`’ file into your patch. If you create any snapshots, the current device labels will be part of the snapshot. However, if you recall older snapshots that have been saved at a time when no device labels were active, that snapshot on the disk will not be changed at all. The snapshot will be loaded onto your console, visualized as it was saved in your General Patch screen; but an instant later the current device labels of your console will be copied into your patch. If you now choose to update your snapshot or make any new ones, these will contain exactly the labels you see on your General Patch screen.

4.4.2.13 Automatic Generation of Intelligent Fixed Labels

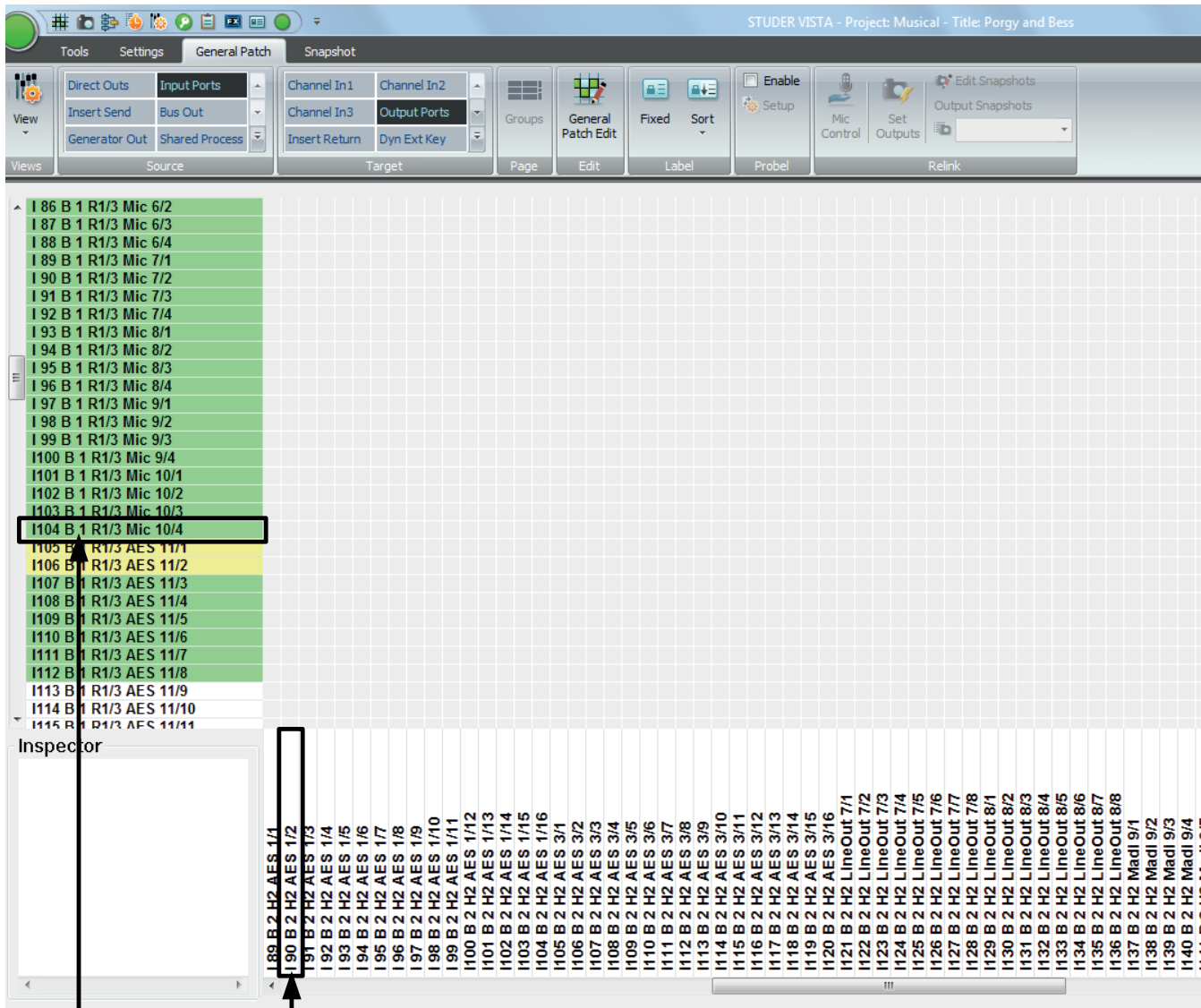

AES input 2 (out of 16) of I/O card 1 inserted in Hub 2 (COM port 2)
Audio is transferred over HD link channel #90, connected to DSP card #2

Mic input 4 (out of 4) of Mic/Line In card 10 (slot 10) inserted in Remote I/O Box 3 (slot 3), connected via MADi to Hub 1 (COM port 1)

Audio is transferred over HD Link channel #104, connected to DSP card#1

Structure of Intelligent Fixed Labels:

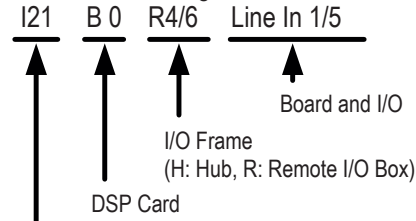

HD Link Channel

Frame numbers represent double-width slot in corresponding hub frame to which the MADi link is connected (1...6).

Card numbers represent slot number of frame into which the card is inserted.

Audio coming through the D21m I/O components is reaching the core over Studer's proprietary HD (high density) link in case of the SCoreLive. This link is present between the local hub(s) and the DSP core. Each link may carry up to 96 audio channels. Instead of displaying these channel numbers in the

general patch, the software is able to give more intelligent names to the input and output ports shown in the general patch. You will then see frame numbers as well as card types and channel numbers within each card. This generation is automatically active whenever the D21m I/O system is present and the hub frame is connected to the console via a serial link. However, when recalling a snapshot containing the 'non intelligent' fixed labels (e.g. from older productions), this will overwrite the fixed labels as well and make the 'intelligent fixed labels' disappear. In this case, select **Regenerate Intelligent Fixed Labels** within the Settings menu and update this snapshot.

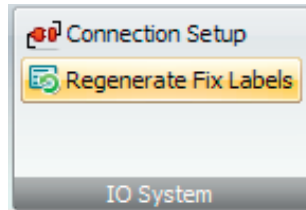

4.4.3 Channel Patch

The Channel Patch page of the graphical controller can be called up in three different ways:

- From the **View** button, by clicking on the appropriate icon
- Using the *Quick Access Toolbar* icons, by clicking on the appropriate icon;
- Using the **CHAN PATCH** function key on the control surface – which is probably the fastest way.

To quickly switch back from General Patch to Channel Patch page, just click the right touch pad button while the cursor is positioned over the X-Y field in the General Patch.

As its name implies, the Channel Patch is channel-oriented, which means that only *one* channel is displayed at a time.

To select a channel to be displayed in the Channel Patch page:

- Press the **LINK/SEL** key on the desired Desk Channel Strip, or
- Use the Channel Selector on the top of the Channel Patch page.

The screenshot displays the Channel Patch configuration page in the Studer Vista 1 software. The interface is organized into several sections:

- Top Toolbar:** Contains various functional buttons such as View, Clipboard, SOLO, Conference, Show Virtual, Machine Control, FX Engine, Jingle Player, Meter/Generator, Shared Delay, VSP Properties, TC-Reader/Gen., N-1 Assignment, Signaling Configuration, Load Configuration, Save Configuration As, Control Group Filter, and Control Group Assign.
- Select Channel:** A dropdown menu currently shows 'Inp m 1'. To its right, 'Usr' and 'Inh' fields are both set to 'Local Mic 01'.
- Input Section:** Includes fields for 'In1' (Local Mic 01), 'In2' (-), and 'Gen' (Generator 1 Generat...). Below these are 'CGM/VCA Assign' and 'Defeat Source Label Inheritance' checkboxes.
- Signal Flow Diagram:** A central vertical chain of processing blocks: Input, 4 Band Eq, Dynamics (with a 'KEY' input and 'Ext' output), Insert Point, Delay, Fader & Mute, Panorama, and Bus. Each block has associated meters and control elements.
- Output Section:** Fields for 'Snd' (-), 'Fx' (Empty), and 'Ret' (-). The 'Dir' field is set to 'MADI out 13'.
- Right Panel:** Contains 'Enable Faderramp' set to 'Always', 'Speed' settings for ON and OFF (both at 0 dB 0 s), and 'Activation' options for GPI, Fader touch, User Key 1, and User Key 2, with an 'Apply' button.

Essentially, the Channel Patch provides a block diagram of the selected channel's audio path. All channel types can be selected. From the Channel Patch, you can:

- View General Patch connections to and from the selected channel;
- Directly access the channel's patch points in the General Patch;
- View channel's DSP processing blocks;
- Set the order of DSP processing blocks in the selected channel's audio path;
- Toggle three-way input selector of the selected channel;
- Toggle selected channel's two-way Dynamics key selector;
- View and edit selected channel's Desk Labels;
- Switch off selected channel's Label Inheritance function;
- Set the Metering source point in the selected channel's audio path;
- Set the Direct Output source point in the selected channel's audio path;
- Setup the Sidechain Links;
- Activate the Sidechain Link for the selected channel.

4.4.3.1 Using the Channel Patch for Patching Audio

The Channel Patch page displays the following channel-oriented patch items of the selected channel for viewing:

In1	The first audio input;
In2	The second audio input;
Gen (In3)	The third audio input;
Snd	The Insert Send;
Ret	The Insert Return;
Ext	The key signal to Dynamics Block;
Dir	The Direct Out.

These labels will be displayed according to the current Label Mode. To edit the patch connection, just double-click the left touch pad button while the cursor is positioned on a connection. This will toggle over to the General Patch page, allowing actions to be performed. The connection you pointed at will be pre-selected automatically.

Examples for channel Im1 (Input Mono 1):

*Double-click on **In1** field*

- toggles to General Patch
- pre-selects Target Im 1 Input m 1 In1
- now only select a Source and patch it.

*Double-click on **Dir** field*

- toggles to General Patch
- pre-selects Source Im 1 Input m 1 DirOut
- now only select a Target and patch it.

Obviously, if the connection you selected is a Source (Snd, Dir), you will only have to select a Target in the General Patch. If the connection is a Target (In1, In2, Gen, Ret, Ext), you will only have to select a Source.

All patch cross-points are saved with snapshots and presets.



Tip

To quickly toggle the display from Channel Patch to General Patch page, just click the right touch pad button while the cursor is positioned anywhere in the Channel Patch page.

To quickly switch back from General Patch to Channel Patch page, just click the right touch pad button while the cursor is positioned over the X-Y field in the General Patch.

4.4.3.2 Setting the Order of DSP Processing Blocks

The following processing blocks (if available in the currently selected configuration) can be placed individually at different locations along the Audio Path of the channels:

- EQ;
- Insert Point;
- Dynamics (Compressor/Limiter/Expander/Gate/Sidechain);
- Delay;
- Fader & ON/OFF Mute.

The actual order of the system blocks is user-modifiable, and can be changed at any time. The order is saved with snapshots and presets.

To change the system-block order, use the familiar drag-and-drop technique:

- Click on the selected blocks, and hold down the touch pad button;
- Available positions in the signal path are shown as a *reversed embossed graphic*;
- Drag the selected block to the required position in the signal path;
- If the block can be inserted at that location, the block name will turn *red*;
- Release the button and the selected block will be inserted into the new location.

4.4.3.3 On-screen Toggles for Input Selector and Dynamics Key Selector

- | | |
|------------------------------|--|
| Input Selector | To toggle the three-way input selector (In1, In2, Gen), click on the switch icon that corresponds to the location at which you want the selector to point. The Desk Input Selector keys will follow the changes, and display the correct source. |
| Dynamics Key Selector | To toggle the two-way input selector (Int, Ext), click on the switch icon that corresponds to the location at which you want the selector to point. |

The selector settings are saved within snapshots.

4.4.3.4 Editing the Channel User Labels

Double-click on the user label field (Usr) to open the Edit window. Proceed to edit and/or change the Desk Label using the same techniques used in the General Patch.

4.4.3.5 Set the Metering and Direct Out Source Point

Set Metering Source Point: To set the Metering Source point in the selected channel's audio path, click on one of the three Meter boxes. The channel meter will now be sourced from the selected point in the signal path.

Available points in the signal path are:

- After Input Block;
- After Fader & Mute;
- After Direct Out level control.

The Meter Source point is saved within snapshots and presets.

Note: There will only be two Meter Source points if Direct Outputs have not been configured for the selected channel.

To set the Metering Source points for more channels at a time, use the Meter/Generator Settings menu (refer to [chapter 4.6.1.2.2](#)).

Set Direct Output source Point: If a Direct Output is included in a channel's configuration, it can be fed from one of three points in the audio path. To set the Direct Output source point, click on one of the three 'wires' connected to the Dir Box (the current connection will be shown *solid*, while the two possible connections are displayed as *dotted* lines).

The Direct Out will now be fed from the selected point in the signal path.

Available points in the signal path are:

- After Input Block;
- Pre Fader & Mute;
- After Fader & Mute.

The selected Direct Output source points are saved within snapshots and presets.

 **Tip** If you have changed the order of the processing blocks, note that the Meter and Direct Out source points will move *together* with the processing blocks to which they are attached (except the Input Block, which cannot be moved).

4.4.3.6 Switch off the Label Inheritance

The Desk Label displays will show Source Labels (from the General Patch) if the console is set to Inherited Label mode and if a source is patched in to the channel. If you wish to remain in Inherited Mode, but do not wish to see Source Labels for certain channels, check the Defeat Source Label Inheritance box. The Desk Label display will now show the name of the channel rather than the Source Label, assuming the user label on the Channel Patch has not been changed from the default. If the user label has been changed on the Channel Patch screen, the Desk Labels will display this user label when the Defeat Source Label Inheritance box has been checked. user labels entered on the Channel Patch screen are saved with snapshots and presets.

4.4.3.7 Setup & Activate the Dynamics Sidechain Link

The effect of a Dynamics Sidechain Link, if activated, is identical to any item of outboard gear set to Link or Stereo mode. This function is used to control between two and eight Dynamics Processors inserted into up to eight different channels. Regardless of which channel is carrying the highest signal level, all processors will provide the *same* gain modification. In this way, Stereo or Multi-channel Surround image stability will be preserved. Unlike in many analog consoles with dynamics units, the channels to be linked do not need to have adjacent locations.

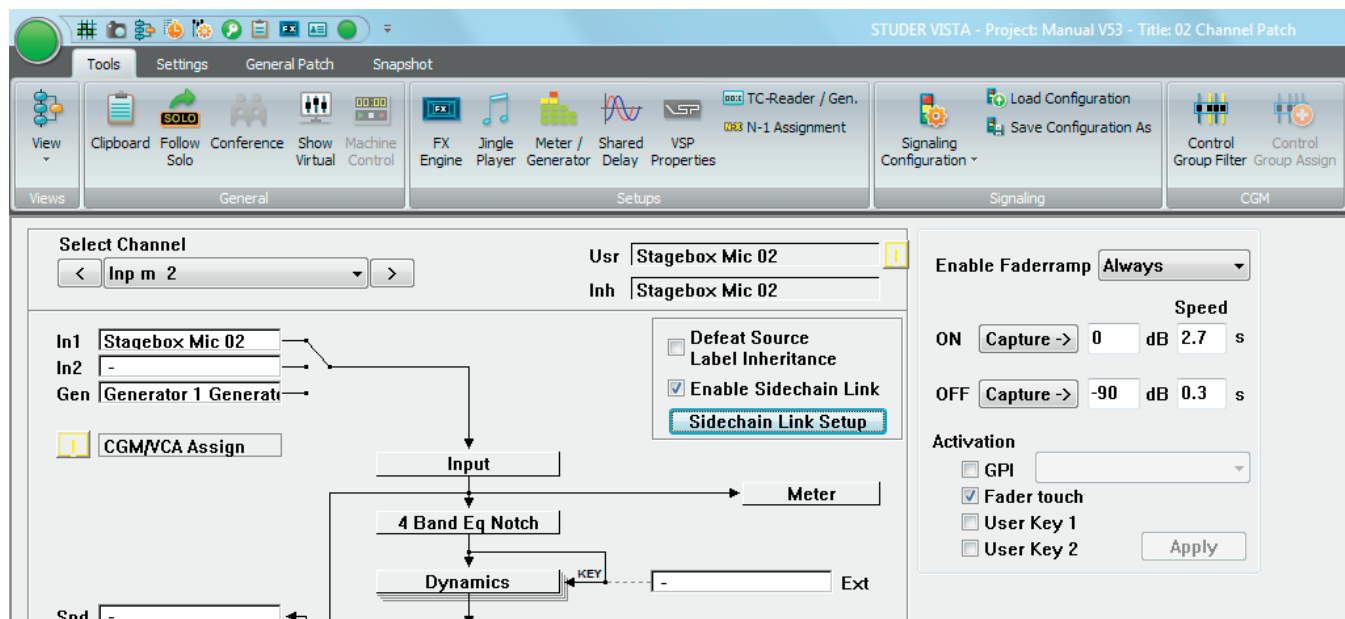

Note: The number of Sidechain Links available (if any) is determined by the currently loaded configuration.

To activate the Sidechain Link for a selected channel, check the Enable Sidechain Link box. This will activate linking of the Sidechain with another channel, or with other channels assigned to that particular Link Group. The channel must be assigned to a Link Group in order for the Enable Sidechain Link box to function. The SCL (Sidechain Link) keys on the Vistonics will follow the selections.

The status of the Sidechain Link is saved within snapshots and presets.

Sidechain Link Setup: Click on the Sidechain Link Setup button to bring up the Sidechain Link editor screen, which allows selecting available links and adding/removing of channels to/from the links.

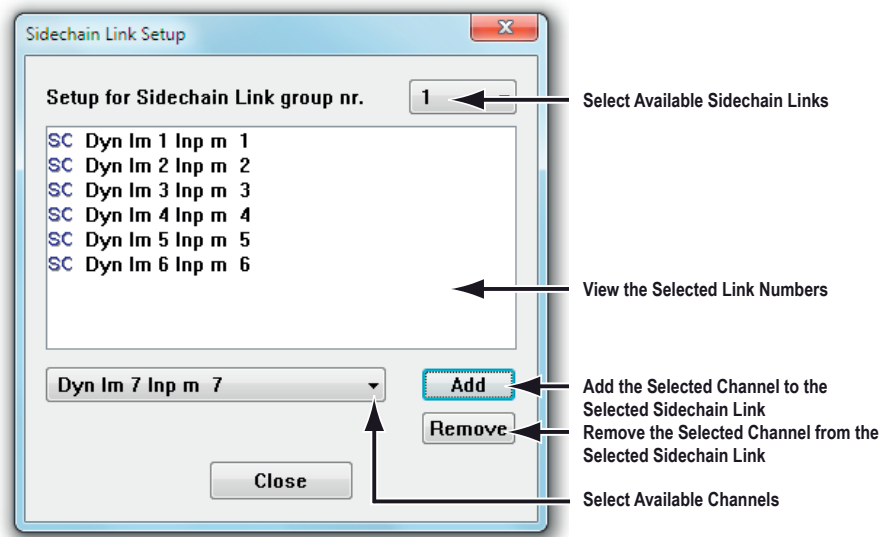

Vista is able to link more than only two side chains – in fact, up to eight – per Sidechain Link. For these reasons, a number of Sidechain Links (each for up to eight member channels) may be defined by the currently loaded configuration. Basically, there can be any number of configured Sidechain Links. A channel can be a member of only *one* Link at a time.

To set up the Sidechain Links:

- Select a Sidechain Link using the on-screen icon;
- If there are any members in the Link, they will now be displayed;
- Add new member channels with the Add button;
- Remove members by selecting one or more of them in the list and pressing the **DEL** key on the keyboard;
- Proceed to edit the next Link number.

Tip If a channel is a member of a Sidechain Link, the graphical representation of its dynamics block in the Channel Patch will change from this

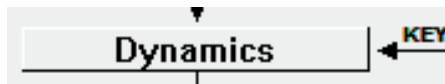

to this:

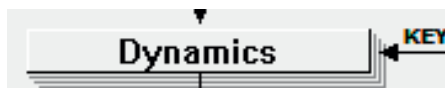

4.4.3.8 Fader Ramp Control ('Audio Follows Video')

The screenshot shows the channel patch window for 'Stagebox Mic 02'. The signal flow is as follows: Input (Stagebox Mic 02) → 4 Band Eq Notch → Dynamics → Insert Point → Delay → Fader & Mute → Balance → Bus. There are three meters: one at the Input stage, one at the Fader & Mute stage, and one at the Bus stage. The 'Fader Ramp Control' panel on the right is highlighted with a black border. It contains the following settings:

- Enable Faderramp: Always
- ON: Capture -> 0 dB, 2.7 s
- OFF: Capture -> -90 dB, 0.3 s
- Activation:
 - GPI: H1 Gpio 13 01
 - Fader touch
 - User Key 1
 - User Key 2

Faders of all console channels can be externally controlled. When using this feature, the console operator determines the Fader Open/Close values, as well as the fade in/out speed. Various triggers are available in order to activate the fade. The channel patch window allows adjustment of all necessary settings. The fader ramp function might be particularly useful when doing TV work. Opening and closing of certain microphone channels may be controlled by the video switcher, using GPIs (general-purpose inputs, i.e. closure contacts on the rear of the desk). Another possible use is radio/TV talk-shows: Different people have their microphones constantly opened and lowered. This action may be pre-programmed, and the fade in/out may be activated by just touching the fader or pressing one of the **USER** keys. The following options may be set in the channel patch window:

Enable Fader Ramp: Select if you want to use one of the two **USER** keys to enable the fader ramp on a specific channel. It is also possible to activate it constantly, leaving the **USER** keys free for other functions.

ON (Fader Value): Clicking on the **Capture** button will set the current fader value to be used when the GPI is active, hence the value used when the fader is opened. Alternatively the value may be typed using the keyboard or by using the touch pad: Click in the number field and drag the pointer up or down. This action is similar to the way time values are adjusted in the dynamic automation of the Vista consoles.

OFF (Fader Value): Clicking on the **Capture** button will set the current fader value to be used when the GPI is inactive, hence the value used when the fader is lowered/closed. Alternatively the value may be modified as described above.

Note: By using the same GPI on two channels and setting the ON value to the 'fader

closed' position on one of the two and vice versa allows using one GPI to control opening *and* closing of different channels at the same time.

Speed ON:	Determines the time used for fading in the corresponding channel.
Speed OFF:	Determines the time used for fading out the corresponding channel.
Activation:	The fade actions may be activated by different events. Several events may be enabled at the same time. The fade will take place whenever one of the activated events is detected:
GPI:	Select one of the general-purpose inputs available on the console for triggering the fade.
Fader Touch:	Touch-and-release the fader in order to activate the fade.
<i>Note:</i>	If the fader is moved while being touched, no automatic fade is being executed. This prevents from accidental fading.
User Key 1/2:	The fade is activated when pressing the corresponding USER 1 or USER 2 key on each channel.
<i>Note:</i>	In case adjusted values should constantly jump back to their previous values, check that the <code>C:\D950System\Sig...ini</code> file is not write protected.

4.4.4 Snapshot Page

The snapshot page of the graphical controller can be called up in three different ways:

- From the **View** button, by clicking on the appropriate icon
- Using the *Quick Access Toolbar* icons, by clicking on the appropriate icon;
- Using the **SNAPSHOT** function key on the console – which is probably the fastest way.

The snapshot page deals with snapshot and preset management. Snapshots and presets are extremely helpful when working with a digital console as they contain the static values for all console parameters. The difference between snapshots and presets is simple: While snapshots can be edited freely, presets are accessible for editing in system administration mode only (refer to [chapter 4.7](#)).

Snapshots are saved within titles, and presets are provided with configurations. Because of this, snapshots are readily available only while using the title in which they were created. On the other hand, all presets that were created for a particular configuration are available in any title that uses that configuration. This allows presets to be used as templates (based upon that configuration), while snapshots are specific to individual projects or sessions. An other difference between snapshots and presets is that any filtering mechanism is active for snapshots only, but not for presets. This means that after having recalled a *preset*, the user can always be sure to have *all* audio settings of this preset applied.

Using the Import facility from the Application menu, it is possible to use snapshots and presets from other titles and configurations, refer to [chapter 4.5.4](#).

Because it is possible to save an *unlimited* number of snapshots, Vista operators will probably find themselves using them more and more every day.

A snapshot or preset will save:

- All audio settings: Fader levels, auxiliary settings, dynamics, delays, input selectors, etc.
- Order of channel processing blocks;
- Direct output and meter source points;
- Bus assignments;
- All labels;
- All patch cross-point connections;
- Channel and other links;
- N-1/mix-minus assignments.

Tip Snapshots and presets always save *every* control and switch setting for the *entire* console. The choice of recalling every setting to every control is up to the operator. A sophisticated filtering system is available in order to keep certain settings even when recalling a snapshot.

4.4.4.1 Snapshots

To capture a new snapshot of the various user controls, press the **MAKE SNAPSHOT** key on the console:

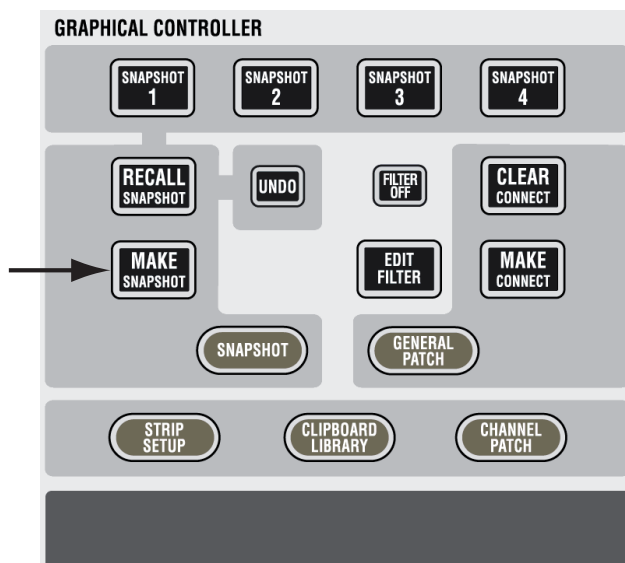

The new snapshot will automatically be numbered like **SNAPSHOT #1**, **SNAPSHOT #2**, etc.

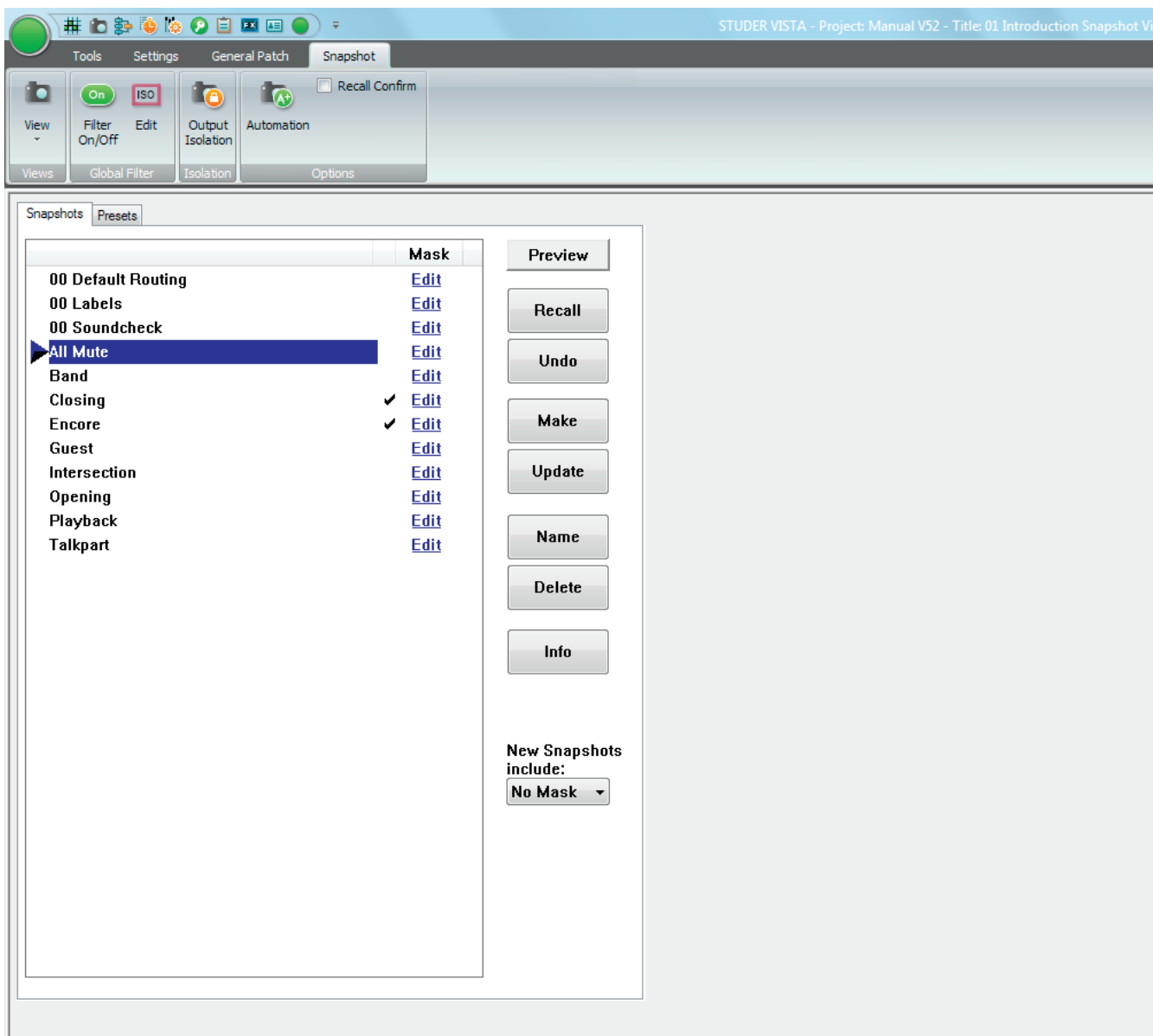

Now You Can: Recall a Snapshot

- Select a snapshot from the List, and
- click on the Recall button, or
- simply double-click on the snapshot you wish to recall.

The snapshot that was recalled last is marked with a small triangle. If the 'Recall Confirm' option in the Snapshot tab, category Options is checked, there will be a pop-up dialog requiring confirmation of snapshot Recall. This capability is useful for live environments, where you may not wish to delete or overwrite too easily what you are doing.

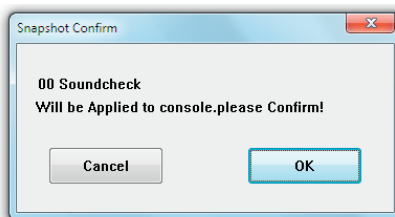

Note: Once a snapshot or preset is applied, the existing parameter settings are replaced by those contained within the snapshot or preset. If the previous settings had not been saved, there is an **Undo** button available, in order to go back to the last settings before recalling the snapshot or preset. This has to be confirmed as well if the ‘snapshot Confirm’ option in the Options menu is active, as mentioned above.

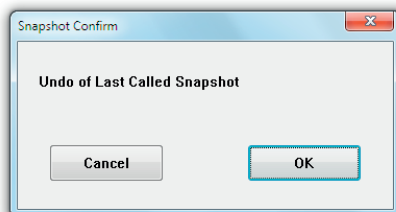

Snapshot Preview

If you are not completely sure whether the selected snapshot is the right one, click on the **Preview** button. Its colour changes to pink, and the Viconics screens indicate the parameter values of the selected snapshot, next to the current values, in pink as well - as shown below for some mono Aux levels:



(Re-) Name a Snapshot

- Select a snapshot from the List, and
- Click on the **Name** button.

This action will bring up a window that allows the user editing this snapshot’s name. Since snapshots are listed in alphabetical order, by carefully naming you can arrange them exactly as you wish.

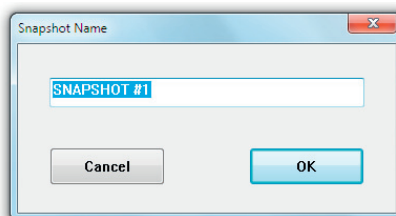

Update a Snapshot

- Select a snapshot from the List, and
- Click on the **Update** button.

This action will bring up a window that allows the user to confirm the update. An update will save any changes you since made under the selected snapshot’s name.

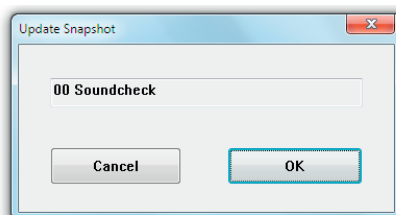

Delete Snapshot(s)

- Select a snapshot from the List, or
- Select any number of snapshots from the List using the familiar Windows multiple-selection techniques (press **Shift** and select the first and the last snapshot with the touch pad pointer, or press **Ctrl** and select whichever you desire with the touch pad pointer). A click on **Delete** will bring up a window to confirm the deletion.

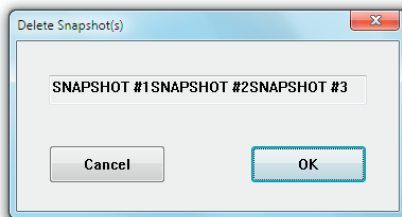

View the Snapshot Info

- Select a snapshot from the List, and
- Click on the **Info** button. This will bring up a window displaying the snapshot Name, the snapshot Creation Date & Time, and the snapshot Last Modification Date & Time.

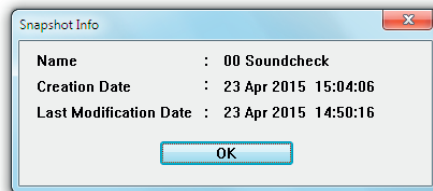

Note Snapshots are saved with the current title; their file extension is *.snp.

4.4.4.2 Multiple Snapshots

Updating Multiple Snapshots

Very often, certain parameters should be overwritten in multiple snapshots. It may be important that only certain parameters are overwritten and others are left as they are in the individual snapshots. In order to achieve this, place those parameters into 'Isolate' mode and recall a snapshot. If this action is now followed by an Update command, the values are changed as requested. By using Trim mode (see chapter 4.4.4.7), it is even possible to apply relative changes to individual parameters of snapshots. E.g. place the fader 1 into Trim mode and lower it by 8 dB. Recall the next snapshot and click Update. This will save the original value of the second snapshot, reduced by 8 dB, to the hard disk. See example #2 below for details.

This can be done even faster: First select multiple snapshots and click Recall and Update once.

Note The **Update** button is changing its name whenever multiple snapshots are selected.

Selecting Multiple Snapshots

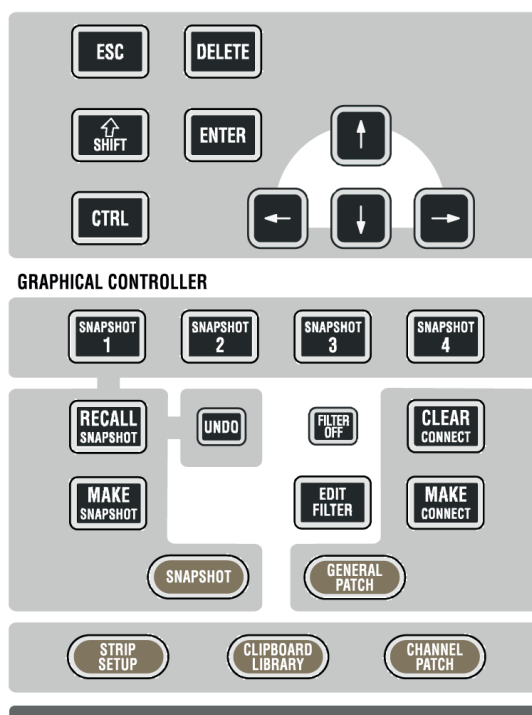

Multiple snapshots can be selected simultaneously by using the keyboard \uparrow **SHIFT** and **CTRL** keys. The selection of multiple snapshots is following standard windows rules: \uparrow **SHIFT** + click selects all snapshots in between the two, **CTRL** + click allows selection of individual snapshots.

Example 1

Goal The value of channel 3 should be overwritten and set to -20 dB on 'snapshot #1', 'snapshot #3', and 'snapshot #5'

Procedure Place the fader to -20 dB.

Hold **ISO** on channel strip 3. Touch the fader in order to put it into isolate mode.

Select 'snapshot #1' with the touch pad.

Hold the **CTRL** key on the control bay, and select 'snapshot #3' and 'snapshot #5'.

Click on 'Recall and Update', and confirm that you want to overwrite these snapshots.

The console will automatically recall and update the selected snapshots.

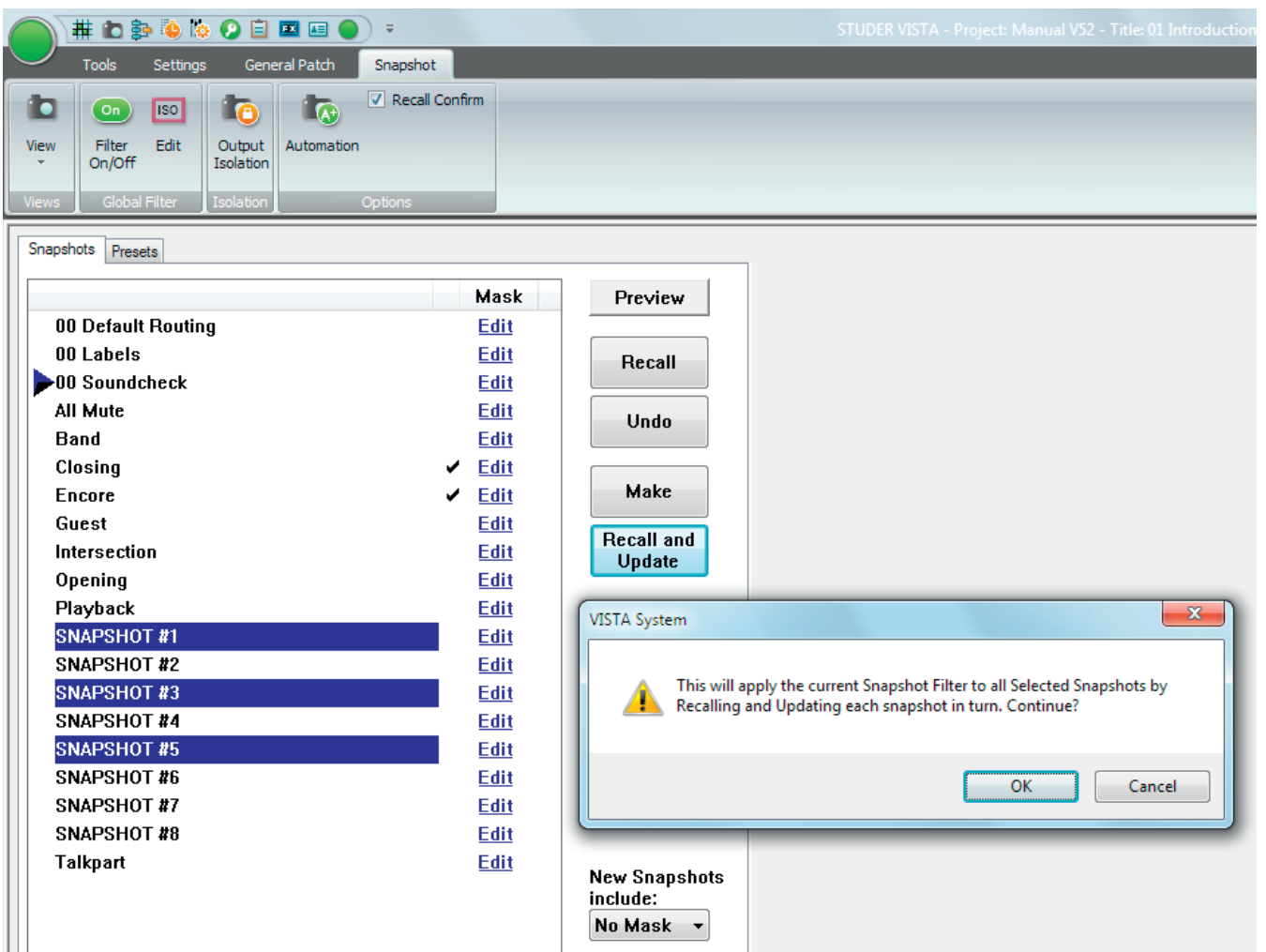

Example 2

Goal The value of channel 3 should be reduced by 4 dB on ‘snapshot #1’, ‘snapshot #3’, and ‘snapshot #5’.

These snapshots currently contain the following fader values:

‘snapshot #1’: 0 dB; ‘snapshot #3’: –5 dB; ‘snapshot #5’: –10 dB.

Therefore, after the update they should contain the new, updated values:

‘snapshot #1’: –4 dB; ‘snapshot #3’: –9 dB; ‘snapshot #5’: –14 dB.

Procedure

Make sure the **Enable Trim mode** option in the ‘Option: snapshot Automation’ menu is set.

Recall any snapshot.

Hold **ISO** on channel strip 3. Touch the fader *twice* in order to put it into Trim mode.

Lower the fader of channel 3 by 4 dB (the exact trim value will be displayed on the Vistonics screen).

Select ‘snapshot #1’ with the touch pad.

Hold the **CTRL** key on the control bay, and select ‘snapshot #3’ and ‘snapshot #5’.

Click on ‘Recall and Update’, and confirm that you want to overwrite these snapshots.

The console will automatically recall and update the selected snapshots.

Since the console assumes that the controls being in Trim mode have been placed into this mode for the purpose of this update, the operator will be asked whether these controls should be taken out of Trim mode afterwards.

4.4.4.3 Snapshot Crossfading

In the Theatre CueList, it is possible to define a crossfade time for each cue - and therefore a crossfade time can be applied to a snapshot. This is done by simply clicking on the crossfade time and scroll your touch pad up or down. If the crossfade feature is deactivated (see [chapter 4.4.5.2.1](#)), it is impossible to adjust the crossfade time.

The snapshot crossfading may be deactivated by deselecting the Xfade Active option on the Theatre CueList.

Settings that cannot be crossfaded (switches) can either switch at the beginning, in the middle of the crossfade or after the crossfade. This behavior can be defined in the Snapshot Automation Options window selected from the Ribbon tab Snapshot, category Options. There, it is also possible to define a Default Crossfade Time.

For an explanation of the Enable Trim Mode option, refer to [chapter 4.4.4.7](#).

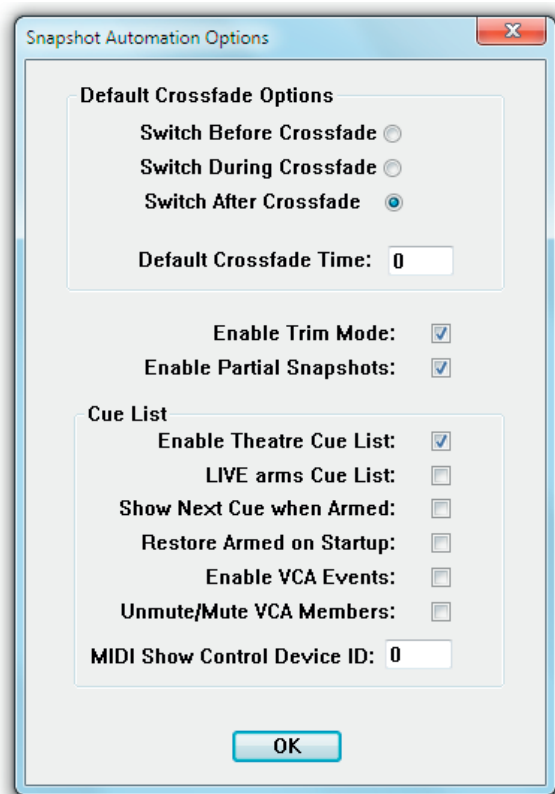

4.4.4.4 Additional Snapshot Functionality

In addition to the dedicated **MAKE SNAPSHOT** hardware key, there are four **SNAPSHOT 1...4** keys for saving and recalling four individual snapshots on these keys.

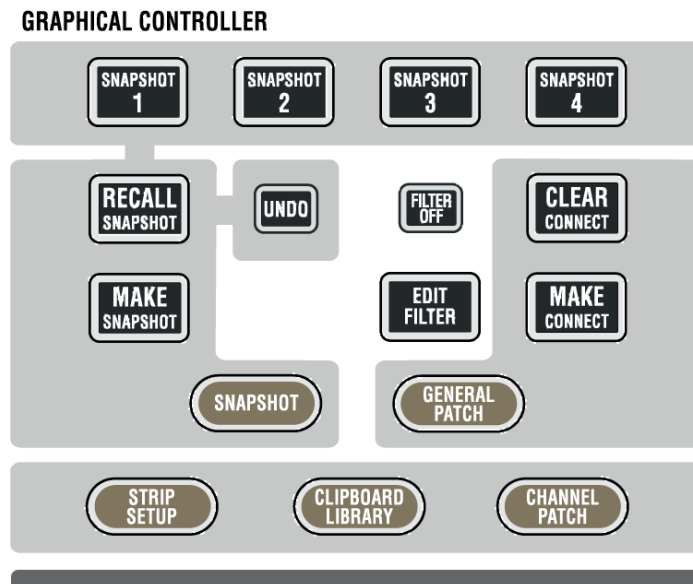

Assign a Snapshot to a Key: To save a snapshot onto one of the 4 keys, *push and hold down* the **MAKE SNAPSHOT** key, then hit the key you would like it to be saved on. Depending on which of the keys you select, a snapshot will be generated in the snapshot List called `__Snapx_Key`, where *x* is the number of the selected button between 1 and 4. This snapshot can now be recalled at any time using the dedicated key by *holding down* the **RECALL SNAPSHOT** key and pressing the desired **SNAPSHOT** key. The need for a two-key operation provides a certain level of security.

A new snapshot can be applied to one of the dedicated keys even if the button already has a snapshot saved to it. In this instance, the previously saved snapshot will be overwritten.

Tip To ensure that a snapshot that has been saved on a dedicated key is not overwritten, and hence lost from the snapshot list, always make the snapshot twice, once to the key and once in the normal way just by pressing the **MAKE SNAPSHOT** key by itself. In this case the same snapshot will appear in the snapshot list twice; once called `__Snapx_Key` and a second time as Snapshot *x*. Rename the latter snapshot as required; this will ensure that the snapshot is not lost even if it is removed from the dedicated key.

Note: It is possible to rename any snapshot already existing in the snapshot list to `__Snapx_Key`. Doing this will put the renamed snapshot onto the chosen hardware key directly without having to recall it first. *Make sure that only one instance of `__Snap1_Key`, `__Snap2_Key`, `__Snap3_Key`, or `__Snap4_Key` exists in the snapshot list at any time.*

Snapshot Preview: By clicking on the PREVIEW button, the console enters this mode. Regardless of which snapshot the user selects, *pink* elements within all Vistonics elements will show any difference between the current console settings and the settings within the previewed snapshot. It is still possible to recall any snapshot by all mechanisms described above.

When pressing any of the four dedicated **SNAPSHOT 1...4** keys without pressing the **RECALL SNAPSHOT** key at the same time, that corresponding snapshot is automatically only previewed. It is also possible to preview it only momentarily by pressing e.g. the **SNAPSHOT 1** key for a longer period; the key will be lit as long as the preview is active.

4.4.4.5 Partial Snapshots

It is possible to create snapshots that do not affect the whole console when recalled. They are called ‘partial snapshots’. When recalling such a snapshot, only some of the channels – or even only some of their elements – are being changed on the desk. Partial snapshots are being marked with a checkmark next to the Edit button.

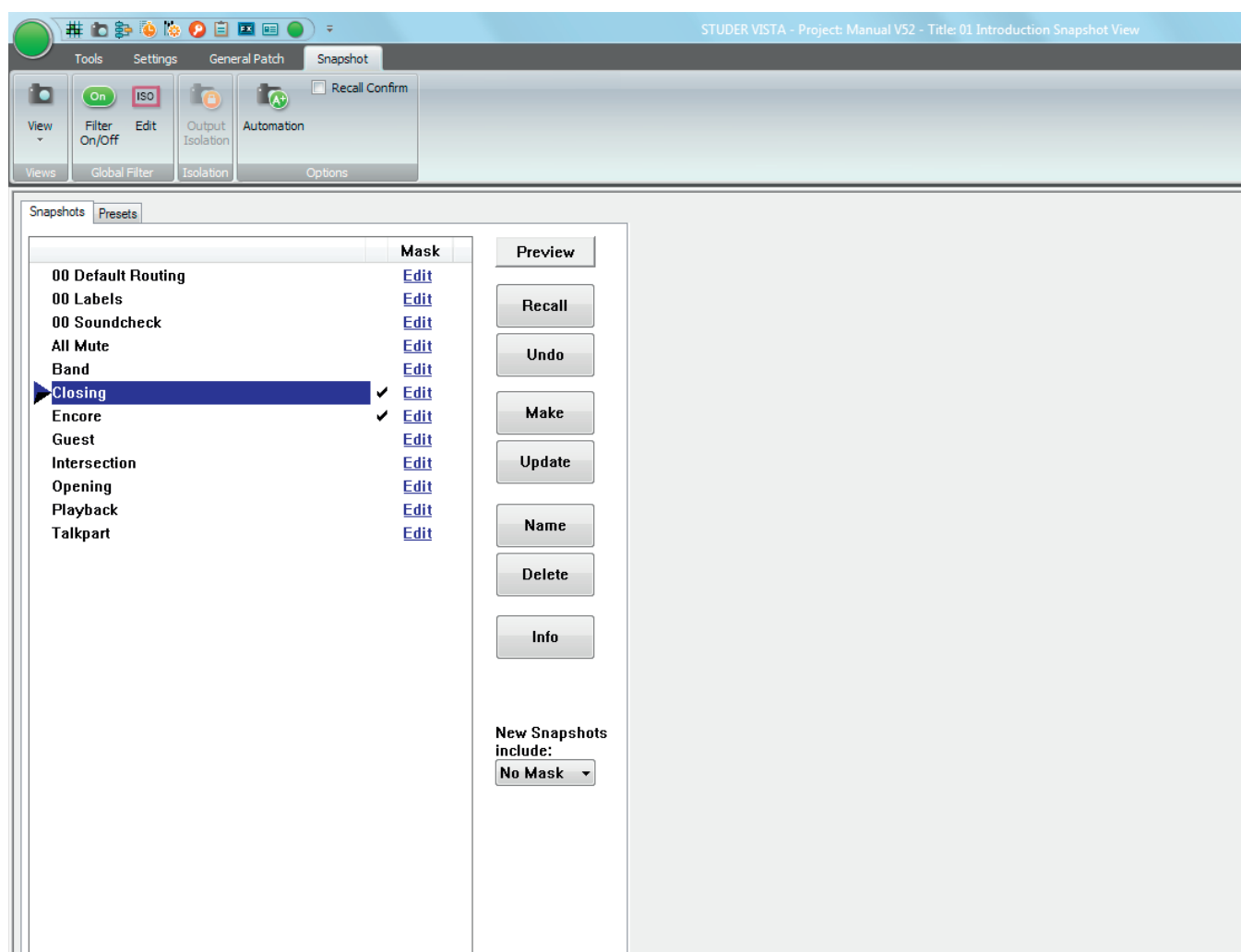

Creating a Partial Snapshot

The easiest way to create a partial snapshot is to gang some channels and make a snapshot, while having the ‘New snapshots include:’ setting set to ‘Gang’:

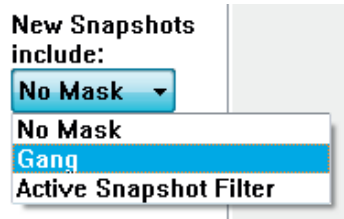

If no gang is present, the whole console settings will be saved in a full snapshot. If the ‘New snapshots include:’ setting is set to ‘No Mask’, there will always be made a full snapshot, regardless of a gang being present or not. It is also possible to set the partial snapshot to ‘Active snapshot Filter’. This will actually create a partial snapshot out of the settings currently *not* masked out by a snapshot Filter.

Saving Snapshot Masks

When working with partial snapshots (option available in ‘Option: ‘snapshot Automation’), it is possible to right-click on the **Edit** link to the right of the snapshots. A context menu will allow not only copying and pasting of masks between snapshots, but also saving and loading of masks to/from files. The files will be saved in the C:\d950System\Users directory.

This function can be very helpful when multiple operators are working on the console. During rehearsals, both operators may randomly save snapshots. After the rehearsal they select ‘their’ snapshots and apply a prepared mask to them. This will make these particular snapshots only influence the part of the console which the operator was working on. Other applications may contain any recall of more complex masks.

Editing Snapshot Masks

If a partial snapshot already has been made and the user finds that he forgot to have some channels in that snapshot, there is a powerful method to correct the mask contained in a partial snapshot. As it has been mentioned at the beginning of this chapter, each snapshot file in general contains all settings of the console. A partial snapshot just adds an invisible mask to the audio settings. Therefore it is possible to enter an edit mode, showing the *mask of a partial snapshot* and giving the possibility to edit it. Let’s say you had channels 1 to 5 in a gang and made a partial snapshot of them, it is easily possible afterwards to tell the system that this snapshot should have also contained the channel 6 data. How to do this?

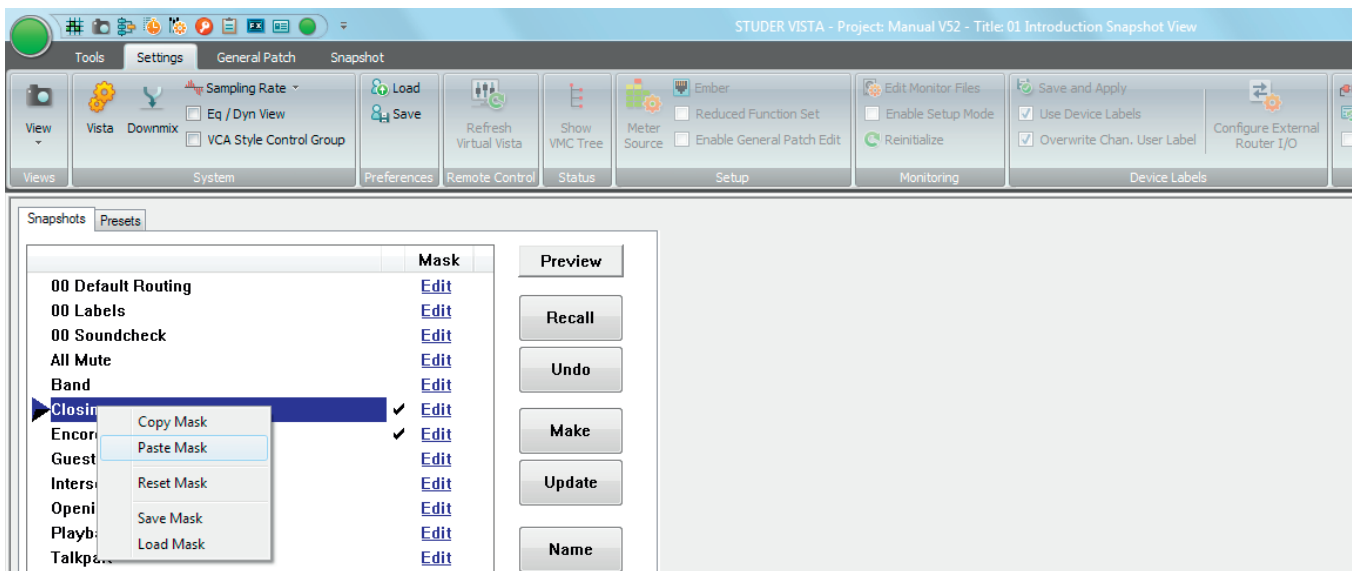

Next to each snapshot there is an Edit link at the very right of the snapshot list. By clicking this button, you will put the console into the 'partial snapshot filter edit' mode. Then you will see the same edit dialog box on the screen as when editing the snapshot filter. Also the desk doesn't show your audio settings anymore, but the mask defining the focus of that partial snapshot. You may now press **ISO** on one or more channels, create a gang, and add multiple channels to the partial snapshot, or touch and press any other control. The same mechanism will apply as when editing the snapshot filter. Upon clicking the Edit link again, you leave the edit mode, and the console is back to display normal audio settings.

When you are not in the edit mode of the partial snapshots mask, you are also able to copy and paste masks across from one snapshot to one or multiple others. Simply *right-click* on the Edit link of a snapshot mask and use the standard windows commands.

4.4.4.6 Typical Applications

Isolate one or more channels from being changed by upcoming snapshot recalls:

Press **ISO** on the corresponding channels. The user may create a gang first in order to isolate multiple channels at a time.

Isolate just the EQ of one or more channels from being changed by upcoming snapshot recalls:

Press and hold **ISO** in order to enter the edit snapshot filter mode, indicated by magenta-colored frames within all Vistonics elements of this channel. *All LEDs will now display their isolation status but not the audio.* E.g. if the EQ button is lit at this time, the EQ is isolated. In order to change the isolation status, press the corresponding key, touch the fader or knob while still holding the **ISO** key. The word 'ISOLATE' will now show up in the generic display area, indicating that some element is currently isolated. You may also use a gang in order to isolate one element of multiple channels.

De-Activate the whole snapshot filtering mechanism on the console

Press **FILTER OFF** on the Control Bay, or click on the snapshot filter icon in the toolbar to de-activate the snapshot filtering while keeping its definition for later use.

Create Snapshots, that contain only some of the channels, but not the whole console

Set the 'New snapshot includes:' option to 'Gang'. Whenever a gang is present, only the gang will be 'part of the snapshot'. If there is no gang, the whole console is affected by the recall of freshly created snapshots. A snapshot not affecting the whole channel is graphically marked by a checkmark (☑).

4.4.4.7 Snapshot Filtering (Static Automation)

At the time of recalling a snapshot, there might be a filter active, leaving some console settings unchanged upon recall of any snapshot. Each console parameter can therefore be in one of the following states:

- Isolate (= part of the filter); this parameter will not be influenced by snapshot recalls. Indication: yellow 'I'.
- Read (= not filtered); this parameter may be changed upon recall of any snapshots. Indication: none.
- Trim (= offsets applied to snapshot recalls); any changes since the last snapshot recall will be applied in a relative way to upcoming snapshot recalls. Indication: red 'T'.

There are some different ways to define the parameters to be filtered out.

Note: The static automation system (filtering) *cannot* be active on a console which has dynamic automation available. The decision which functionality is available is made by an entry in a *.ini file before the system is re-booted, or by using a special way to boot the system (alternate icon on the desktop).

Channel-Based Masking

You may add whole channels or only parts of them to your mask by pressing the channel strip **ISO** key.

Entering Edit Filter Mode

When you click the Edit snapshot Filter button in the toolbar, you will put the whole console into edit snapshot filter mode. Exit by clicking/pressing the same button or key again. While the console is in edit snapshot filter mode, it is not primarily showing audio settings, but actually visualizing the snapshot filter. Each LED will indicate that this parameter is currently part of the snapshot filter, meaning being filtered out from snapshot recalling. Vistonics elements are indicating a small letter 'I' – Vistonics keys change their color to yellow if they are part of the snapshot filter. E.g. seeing the EQ key lit will indicate that this equalizer is currently part of the snapshot filter including all its parameters. If the key is half-lit, there are some – but not all – parameters of that equalizer part of the snapshot filter. If dark, it indicates that none of the equalizer parameters are part of the snapshot filter. You may make the whole equalizer be part of the snapshot filter or not by pressing its key.

If the console is in edit snapshot filter mode, this is indicated by the opened EDIT SNAPSHOT FILTER window (as shown below); on a Vista console, the Vistonics elements are marked by magenta-colored frames in addition.

Notes It is of course also possible to use ganging in order to add an element of multiple channels to the snapshot filter.

To add a whole channel to the snapshot filter, press the **ISO** key on the channel strip.

Also the copy/paste mechanism works in order to copy selections across one or multiple channels.

Adding a Whole Bus to the Snapshot Filter

In edit snapshot filter mode (as described above), the following window is shown on the GC screen:

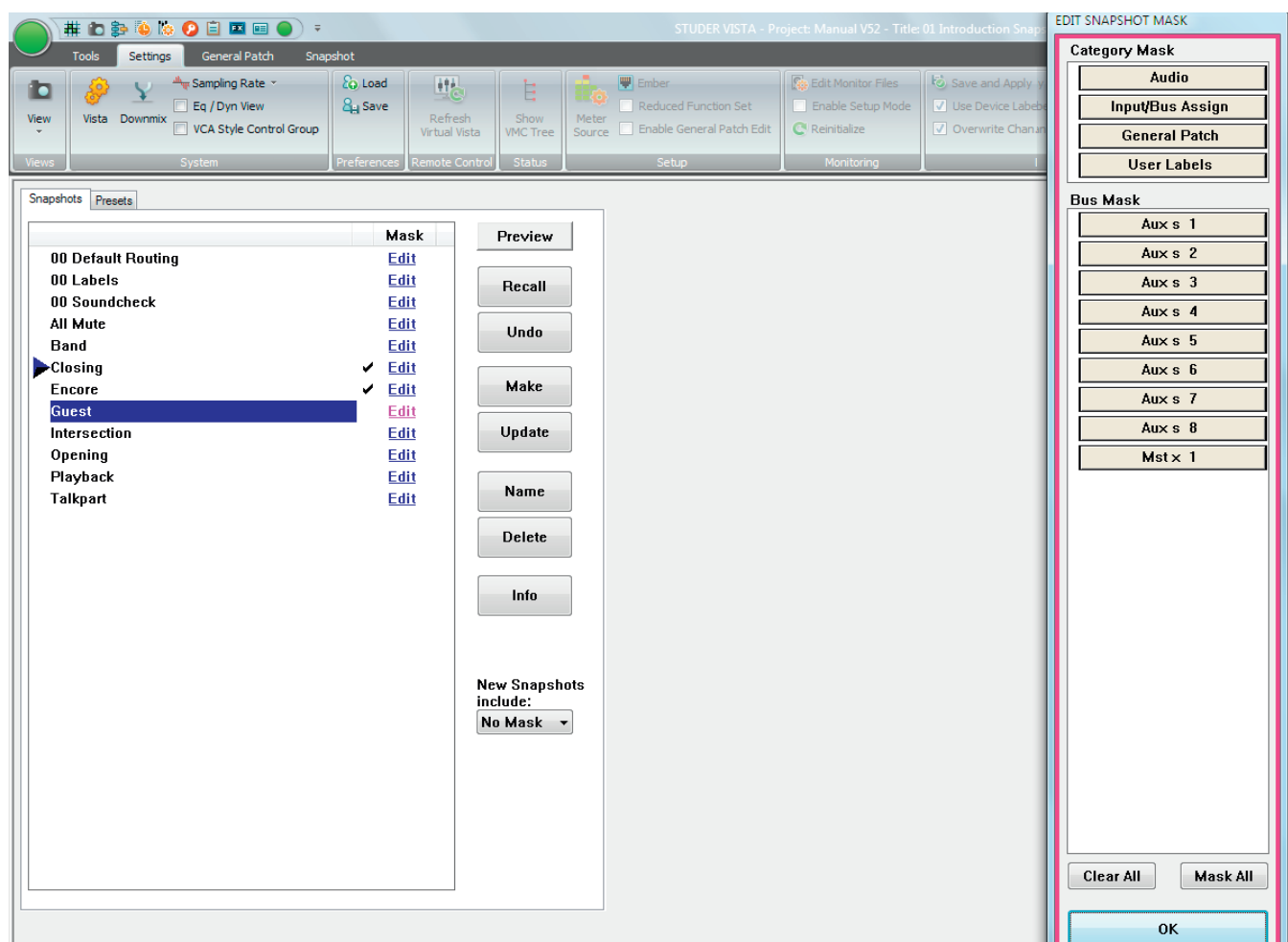

This window allows adding a whole group of parameters to your snapshot filter. Either select one of the four groups on top, or one of the listed busses.

- Audio Settings:** Will add all channel processing functions to your snapshot filter.
- Input/Bus Assign Settings:** Will add the input switches of all channels as well as all bus assignments to your snapshot filter.
- General Patch Setting:** Will add the General Patch to your snapshot filter, meaning that no patch points will change when recalling a snapshot.
- User Labels:** Will add all user labels (within the General Patch as well as within the channel strips) to the snapshot filter.
- Bus:** This is a very powerful feature. By clicking e.g. on 'Aux m 1', you will add all relevant parameters to your snapshot filter, such that the Mono AUX Bus 1 will not be influenced by any snapshot recalling. Included are:
- The levels of all channels routed onto that bus
 - The bus assign (on/off switch) of all channels for that bus
 - The corresponding master channel with all its settings
 - The output patch made from that master channel to any output ports.

Caution: Clicking on the 'Clear All' button will completely remove the snapshot filter and therefore may change all console parameters upon the next snapshot recall.

Clicking on the 'Mask All' button will protect the whole console (with some exceptions, such as Patch points) against snapshot recalls, afterwards allowing to enable just single elements to be activated.

De-activating Snapshot Filters

It is possible to de-activate an existing filter in order to re-activate it at a later point. Click on the corresponding icon in the toolbar to activate/de-activate the current snapshot filter.

If the snapshot filter is de-activated, the icon for entering the snapshot filter edit mode is grayed-out and not accessible.

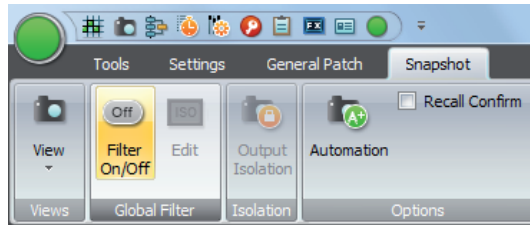

Trim Mode

It is also possible to put elements into Trim mode. In that mode, you may have recalled a snapshot and make some corrections (e.g. push the fader up by some dB). This change will then be applied to all following snapshots when recalling them. This feature is very handy if you have prepared a performance and need to correct some levels when the show really starts. Obviously it is good to have that correction applied to all snapshots of the show.

Note: When going back to Read mode, the elements will jump back to the original snapshot value.

In order to activate the Trim mode as a third possible status of the elements, the Enable Trim Mode option must be activated in the snapshot Automation Options window. Then the snapshot filter will not only contain two (Read and Isolate) but three modes: Read, Isolate, and Trim. Switches cannot go into Trim mode, therefore their indication is not different (yellow 'I'). However, the rotary controllers and faders will toggle between 'Read', yellow 'I' for 'Isolate' and red 'T' for 'Trim'.

4.4.4.8 Presets

Presets are exactly the same as snapshots. However, they normally can only be recalled but not edited; so their main purpose is to represent – as the name implies – a number of starting console setups that can be recalled, used to build particular refinements from there, and then saved as normal snapshot files.

To access presets from the snapshot page, click on the presets tag. Presets are saved within the configuration, because it is assumed that they may be valid for more than one title.

The file extension is *.pre.

If the system administration mode (refer to [chapter 4.7](#)) is activated (by entering the appropriate system administrator password), presets can be edited exactly in the same way as snapshots.

4.4.4.9 Default Settings

In the preset List, there is always one line labeled *defaultSettings*. This is a preset that is automatically generated for every Session Configuration, but no file will be found in the corresponding Session Configuration directory (as would be the case for other presets).

When recalled, the *defaultSettings* will reset the console to the defaults – it functions much like a Total Reset.

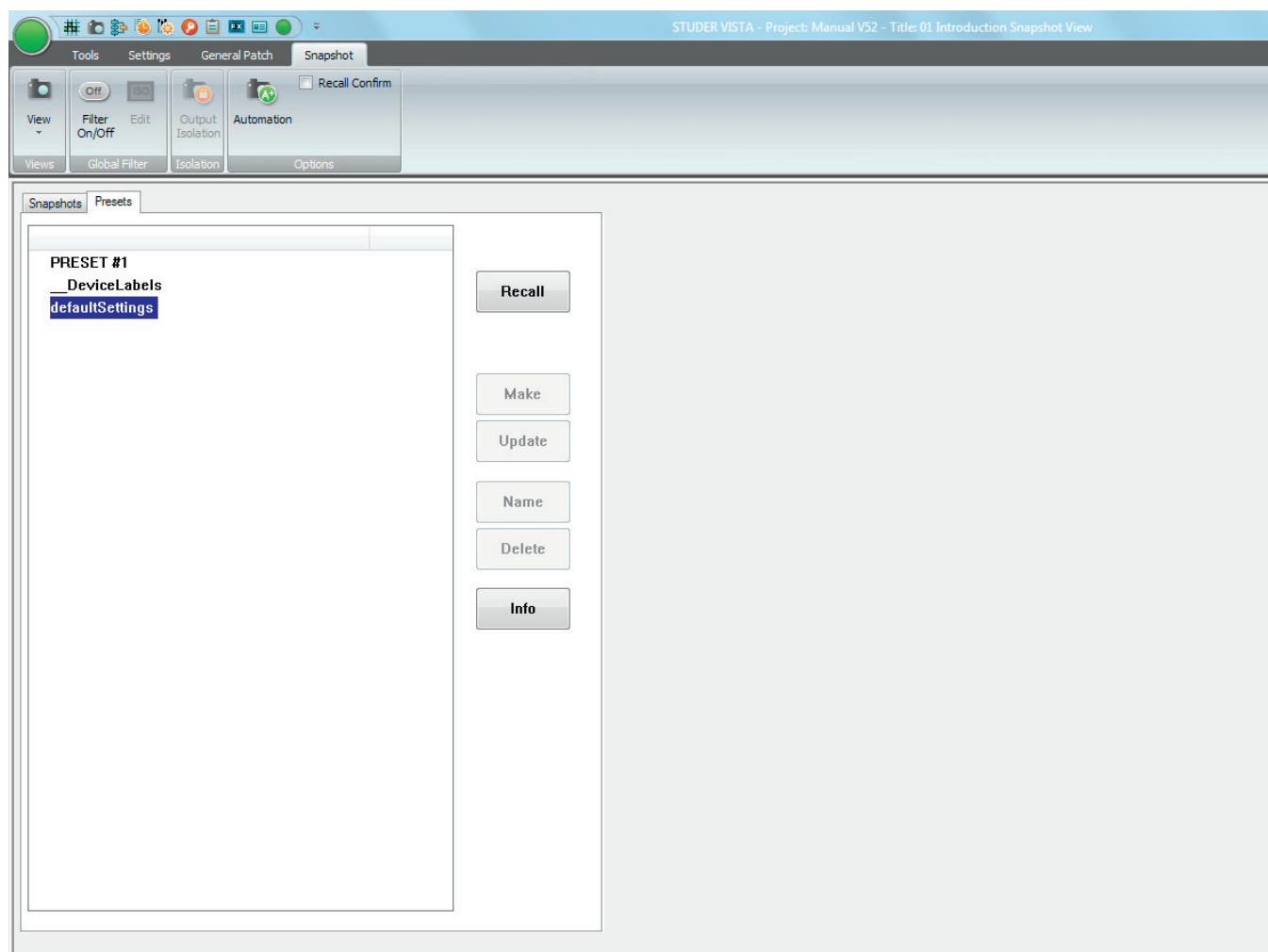

DefaultSettings *cannot* be edited, renamed, deleted or updated.

4.4.4.10 Files and Backup

Snapshots and presets are saved as Windows-compatible files.

Usually, snapshots are saved in the current title directory, with a *.snp file extension.

Usually, presets are saved in the Session Configuration directory, with a *.pre file extension.

All snapshot and preset files can be copied or moved to and restored from a backup medium using the Make/Restore Backup facility (refer to [chapter 4.5.3](#)).

4.4.5 Cue List / Theatre Cue List

Two different cue list functionalities are available that allow sorting snapshots and attaching MIDI, HiQNet and other events to each one of them. Each title can contain only one single cue list. It can be controlled from external controllers using MIDI. It is possible to use standard 'MIDI show control' commands as well as recalling certain cues with a user-defined MIDI command (note or program change). *The Theatre Cue list is only available in 'static' mode, hence not when dynamic automation is active.*

The Cue List page of the graphical controller can be called up in three different ways:

- From the View button, by clicking on the appropriate icon
- Using the *Quick Access Toolbar* icons, by clicking on the appropriate icon;
- Using the **CUE LIST** function key on the console – which is probably the fastest way.

4.4.5.1 'Standard' Cue List

The screenshot displays the Studer Vista software interface. At the top, there is a menu bar with 'Tools', 'Settings', 'General Patch', and 'Snapshot'. Below the menu bar is a toolbar with various icons for 'View', 'Clipboard', 'Follow Solo', 'Conference', 'Show Virtual', 'Machine Control', 'FX Engine', 'Jingle Player', 'Meter / Generator', 'Shared Delay', 'VSP Properties', 'TC-Reader / Gen.', and 'N-1 Assignment'. The main area is divided into two panels. The left panel, titled 'Cue List', contains a list of cues with their timecodes and names:

00:00:00.00	__Loc1 Key
00:00:03.10	Intro
00:00:05.00	CUE #12
00:00:15.19	CUE #13
00:01:05.16	CUE #2
00:01:10.00	Chorus A
00:01:15.03	CUE #4
00:01:20.11	CUE #5
00:01:24.16	CUE #6
00:01:38.04	Chorus B
00:02:14.21	Bridge
00:02:49.16	CUE #16
00:03:14.09	CUE #17
00:03:32.01	End

The right panel, titled 'Generator', shows a 'TC Reader' with a timecode of 00:03:33.24. It includes playback controls (stop, play, record, solo) and options for 'From: Intro' (00:00:03.10) and 'To: End' (00:03:32.01). There are also radio buttons for 'Play(Loop)', 'Rehearse', and 'Auto Rec.', and a 'LOC' button.

The cue list helps to deal with parts of a musical piece or film you want to keep track of in time. That could be items such as Intro, Chorus A, Bridge, Chorus B, the End of a song, or a scene from the film you might want to (auto-) locate to. An unlimited number of cues can be stored.

Each cue in the cue list has a timecode stamp and a name. The names are generated and numbered automatically when making cues, but may be edited

at any time along with the TC stamp. The cues in the cue list are automatically sorted by increasing TC. If you make a new cue, it will be inserted into the list according to its TC stamp.

When the running TC passes a cue point existing in the list, a small triangle will appear next to the cue to indicate that this particular cue has been reached. The triangle will remain there until the next cue in the list is reached, and so on.

Capture To quickly make a cue (and edit the name and/or timecode stamp later, if necessary), click on **Capture** in the GC's cue list window when you hear the audio event to be marked:

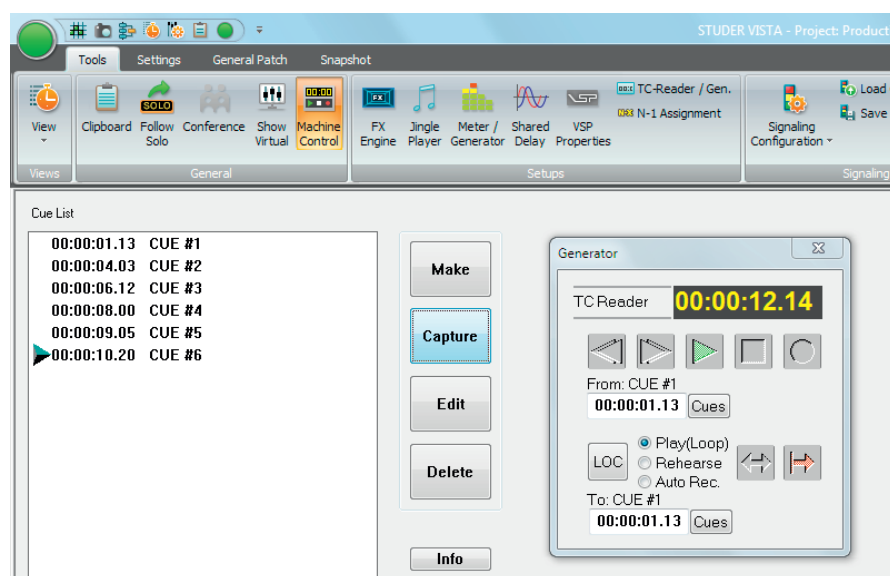

In both cases, a cue point will be generated, automatically numbered, and stamped with the current timecode address at the moment the key was pressed.

Make Making a cue means:

- First enter a name within the edit window that appears when you click the Make button

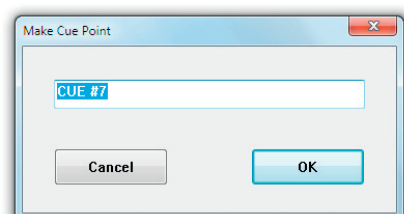

- Wait for the right audio event to occur, and click the on-screen OK button, or press the **ENTER** key on the desk keyboard

A cue point with the entered name will be generated and stamped with the current timecode as soon as you click OK or press **ENTER**. You can edit both name and TC stamp later, if necessary.

Edit Opens an edit window that allows changes to be made to the name and the timecode stamp of a selected cue from the cue list.

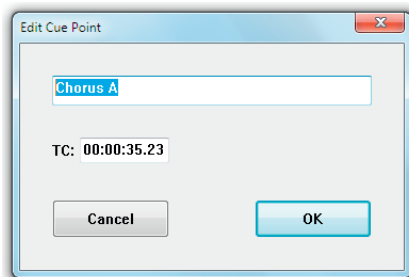

Delete Opens an edit window that allows one or more cues to be deleted from the list. Select a cue in the list by clicking on it, or select any number of cues from the list using the familiar Windows multiple-selection techniques (drag on the touch pad, or press **SHIFT** and select with the cursor). Click on the **Delete** button. This action will bring up a window asking you to confirm the delete operation.

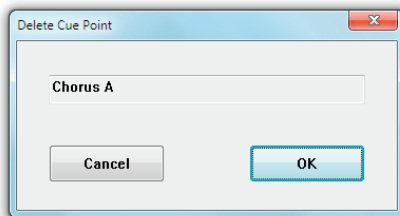

Info Calls up cue info:
Click on the **Info** button; that will bring up a window displaying

- Cue list name;
- Cue list creation date and time;
- Cue list last modification date and time.

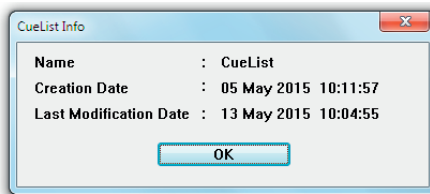

Tip To enter timecode values, use the control surface keyboard's numeric keypad. The keypad features a double-zero key (00) to speed up the process. You do not have to enter any punctuation marks – i.e., no colons or commas between hour, minute, second, and frame values – since they will be added automatically.

Click-and-Scroll Method This is an alternate method for fast timecode entries. It is initiated by the clicking-and-holding the left touch pad button followed by a touch pad move in vertical direction.

4.4.5.2 Theatre Cue List

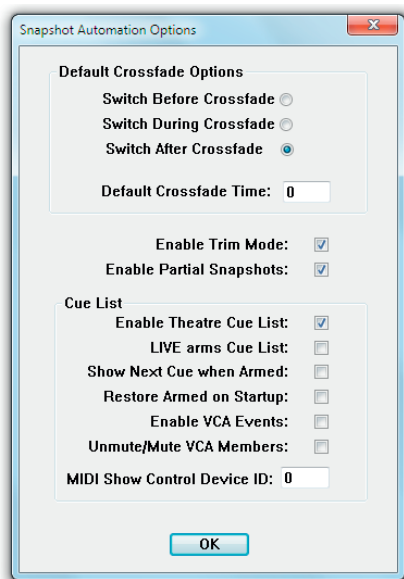

In order to activate the ‘theatre cue list’ functionality, enter the Ribbon tab Snapshot, category Options, opening the “Snapshot Automation Options” menu and tick the Enable Theatre Cue List item (the further menu options are described in [chapter 4.4.5.2.15](#)). The cue list window looks similar to the screenshot below. A detailed theatre workflow tutorial is given in [chapter 4.4.5.3](#).

In addition, the `D950system.ini` file must be modified by the system administrator with the following entry: `[options] - TheatreMode=Yes`.

The *Virtual Vista application* not only lends itself for offline system setup, but also for preparing a theatre cue list for a new show, while e.g. the console is still used for the show currently played. For details of Virtual Vista, please refer to [chapter 2.2.12](#).

#	Name	Snapshot	XFade	VCA	Events
1	Introduction	Basic	2.0	[MUTE]	[Event]
2	Jasbo Brown Blues	Act1Sc1	2.0	[MUTE]	[Event]
3	Summertime 1		2.0	[MUTE]	[Event]
4	Roll dem bones		2.0	[MUTE]	[Event]
5	I works all de week		2.0	[MUTE]	[Event]
6	Summertime 2		2.0	[MUTE]	[Event]
7	Listen to your daddy		2.0	[MUTE]	[Event]
8	Cant anybody make Crown stop		2.0	[MUTE]	[Event]
9	You done bring trouble enough		2.0	[MUTE]	[Event]
10	Where is brudder Robins	Act1Sc2	2.0	[MUTE]	[Event]
11	Come on Sister		2.0	[MUTE]	[Event]
12	Gown got plenty		2.0	[MUTE]	[Event]
13	Overflow		2.0	[MUTE]	[Event]
14	My mans gone		2.0	[MUTE]	[Event]
15	How de saucer stan now		2.0	[MUTE]	[Event]

The theatre cue list contains the Snapshots, Events and Configuration areas at its left. The Snapshots area shows the currently available console snapshots; they can be dragged-and-dropped into the desired cue row of the cue list’s # column. The Events area allows dragging-and-dropping the desired events into the cue list’s Events column. If one of the events is selected, the Configuration area shows the settings and options useful for the current

event.

A click on the **Library Entries** button opens the cue actor overview window that gives a comprehensive overview of all library events.

At the bottom of the theatre cue list window, the name of the current cue (and snapshot, if appropriate) is indicated in large characters so that it may be clearly read even from a certain distance. The last and the next cue's names are displayed as well at the upper or lower border of this indication field in small characters. Any desired cue from the list can be recalled either by double-clicking on its name or by using the **PREV** or **NEXT** buttons.

The buttons at the right-hand edge of the theatre cue list:

Cue Name and Number	The Name # button is used for entering/editing a name for the currently selected cue, and for manually editing its number.
Make a New Cue	Make inserts a new cue below the one currently selected. Its number is generated automatically. If the selected cue is, e.g., #14, the new cue's number will be #14.5, and its name will be Cue 14.5; a next one will be #14.75, etc.
Renumber Cues	After having edited the theatre cue list by making new or deleting cues, the Renumber button allows renumbering a selection of cues. In order to renumber the complete list, simply select all cues before.
Make Cue and Snapshot	The Cue and Snapshot - Make button allows generating a cue, together with a snapshot of the whole console, in one go; the new cue is named according to the rule given above, and its name will be 'SNAPSHOT #x'. With Snapshot Update , the snapshot of the selected cue is updated with the current console settings; this can be undone using Snapshot Undo .

4.4.5.2.1 Cross-Fading Between Cues

Each cue displays a value for the cross-fade time when activating this cue. To modify the cross-fade time, point to the digits, hold the left touch pad button, and scroll up or down. Alternatively, enter the number using the numerical keypad.

When clicking on the cross-fade time once, options for the behavior of switches during cross-fades become visible in the left part of the window (Options Area). For each cue it can be defined whether the switches should change their state before, in the middle, or after the cross-fade – while the other parameters are changing seamlessly.

Within a cue, a partial snapshot may be recalled, influencing only certain parts of the console. If a larger cross-fade time is applied to this and the next cue is recalled before the last cross-fade has been finished, there will be two cross-fades happening at the same time, possibly with different cross-fade times. Only if the two cues change the same parameters, the first cross-fade will stop and the second one is applied from this point onwards.

Example

Given: All Faders are set to 0 dB.
Cue #1 contains a partial snapshot, setting faders 1...10 to -20 dB, cross-fade time 10 s.
Cue #2 contains a partial snapshot, setting faders 11...20 to -40 dB, cross-fade time 1 s.

Procedure: Recall Cue #1, e.g. by double-clicking on its name. Faders 1...10 will start moving down slowly.
Five seconds later, Cue #2 is recalled. Faders 11...20 will start moving down. After six seconds, faders 11...20 have finished their cross-fade and are set to -40 dB.

After ten seconds faders 1...10 also have finished their cross-fade and are set to -20 dB.

4.4.5.2.2 Organizing Events

It is possible to move events from one cue to a different one by using drag-and-drop. Also, snapshots may be moved between cues using drag-and-drop. In this way, snapshots can be replaced or exchanged within cues.

4.4.5.2.3 Updating Snapshots

The snapshot names displayed in the cue list are only referring to the corresponding snapshot contained in the snapshot list. It is therefore possible to use the same snapshot in multiple cues, possibly using different cross-fade times. When updating a snapshot, the cues containing it will automatically use the updated snapshot.

Note Snapshots can be updated from within the cue list window; right-click on the snapshot within the snapshot list in the top left corner in order to get different options, such as **Make**, **Update**, **Name**, etc.

Alternatively a button has been introduced which allows updating a snapshot directly out of the cue list window.

MIDI MIDI note and program changes can be used both as sources for firing a cue, or as events to be sent out of the console upon recalling a cue. In order to attach a MIDI command as a cue trigger, drag-and-drop the MIDI icon to the left side of the cue name. If a MIDI command should be sent out upon cue recall, drag-and-drop the MIDI icon to the right side of the cue. Multiple events may be added to the right side of a cue.

4.4.5.2.4 BlackOut

It is possible to make the whole console surface go dark. This function is useful in case complete darkness is required, e.g. in a theatre environment. This function also includes the optional console illumination. It can only be activated if the cue list is armed. The console lights come back on again either by the next BlackOut event (Parameter: OFF) or by pressing **F3** in the control bay.

4.4.5.2.5 Arm CueList

To avoid undesired influence by external devices, the cue list inputs may be armed or disarmed. If not armed, the BlackOut function, the MIDI IN events, and the **NEXT** and **PREVIOUS** keys in the control bay are disabled.

It is possible to set the default value of the **ARM CUELIST** button by using the Snapshot/Snapshot Automation Options menu.

4.4.5.2.6 XFade Active

It may be useful to temporarily disable cue cross-fades (e.g., during rehearsals). This can be done by un-checking this item.

4.4.5.2.7 Preview

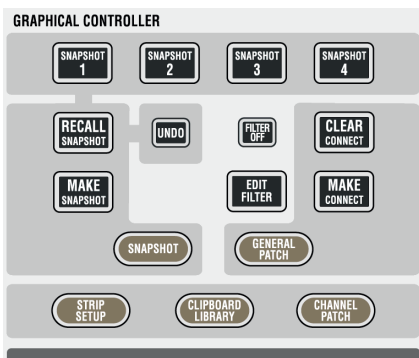

The snapshot/cue preview mode can be activated either by a hardware key or by clicking on the button located in the top right corner of the cue list window. When in preview mode, the cue or snapshot currently selected (single click) is compared to the current audio settings. If there is a difference, Vistonics shows both values at the same time, using a pink graphical indication. When pressing the dedicated snapshot keys above the touch pad, the preview mode is automatically activated until the same key is pressed again.

4.4.5.2.8 MIDI Show Control Device

It is possible to control the cue list by using ‘MIDI Show Control’ commands. the Vista console acts as a slave in this case. The following ‘MIDI Show Control’ commands are supported: Go, Stop, Resume, Load, Reset, Standby+, Standby-, Sequence+, Sequence-. Vista is designated as a Music Command Format (0x11). The MIDI device ID is set in the ‘Option: snapshot Automation’ menu.

Examples

- Next Cue: F0 7F [Device ID] 02 11 01 F7 (Go command)
- Previous Cue: F0 7F [Device ID] 02 11 12 F7 (Standby Command), then F0 7F [Device ID] 02 11 01 F7 (Go Command)
- Recall Cue 3.5: F0 7F [Device ID] 02 11 01 33 2E 35 F7 (Go Command with Q specified)

4.4.5.2.9 MIDI Port Deactivation

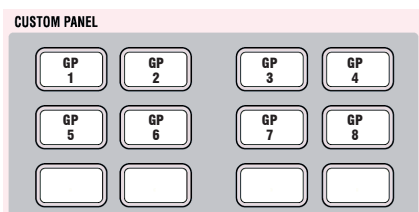

For enabling or disabling (cutting) the MIDI control input and output ports, two of the CUSTOM PANEL 7-12 desk keys can be used

The MIDI In port can be disabled, in addition (together with the blackout function as well as the hardware NEXT and PREVIOUS keys on the console surface) using the ARM CUELIST button in the theatre cue list. Different options can be set in the Snapshot/Snapshot Automation Options menu.

4.4.5.2.10 Event Types

Library Events

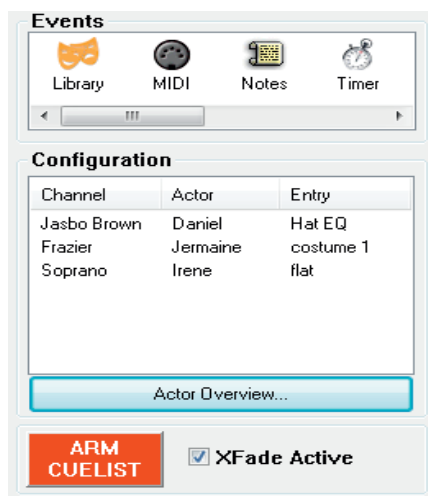

Cue-based theatre productions need a large number of parameter changes per channel, usually for a number of subsequent cues.

Example: In scene 3, the character Jasbo Brown played by Daniel wears a wide-brimmed hat, changing the sound of his lavalier microphone due to reflections.

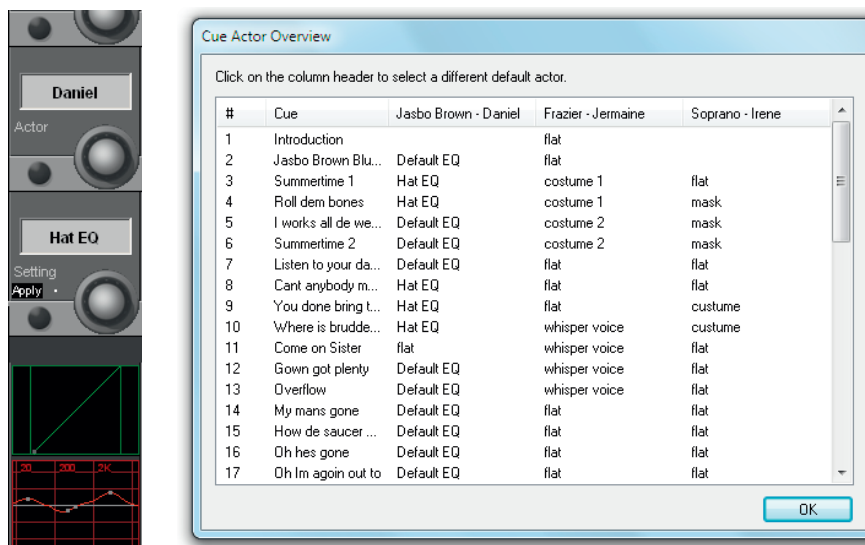

The solution is to modify the EQ of his channel in order to make up for the different microphone response. This is valid for cues 3, 4, 8...10, etc., ('Hat EQ'). For cues 5...7, the original EQ settings have to be applied, while cue 11 demands for a flat EQ. This can easily be achieved with Library Events. They may be adjusted while running the show, without the need to update the cue settings that are ahead of the current cue.

A detailed theatre workflow tutorial is given in [chapter 4.4.5.3](#).

MIDI/MMC Events

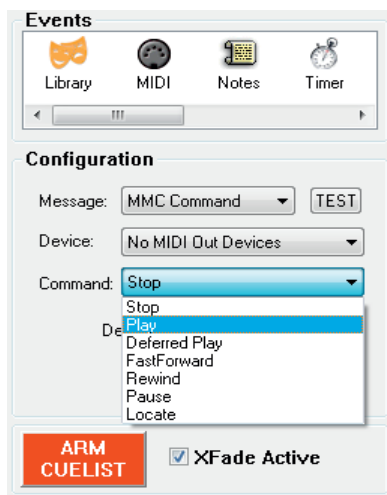

The MIDI/MMC (MIDI machine control) event type can either be used for automatically sending MIDI commands if the symbol has been entered into the **Events** column (such as Program, Note On, Controller, MMC and Sysex), or for triggering the associated cue on arrival of the command if the symbol has been entered into the → column (such as Program, Note On or Controller).

MMC commands are a subset of the MIDI Sysex ('system exclusive') command set that are used for triggering transport commands for external playback equipment, such as Stop, Play, Locate, etc.; 'Deferred Play' is a Play command that is executed after the playback transport has found the desired cue position.

A MIDI event is entered either by dragging it from the **Events** area and dropping it into the **Events** column of the selected cue, or by a right-click into the **Events** column of the selected cue and selecting the desired event from the dropdown list. It can be configured in the **Configuration** area, or deleted if highlighted by a click and either pressing **Del** on the keyboard or clicking on the **Cue Delete** button.

If MIDI input control signals are used, a MIDI event symbol is inserted into the → column of the cue list, either by dragging-and-dropping it from the **Configuration** area or just by double-clicking into the desired cue list cell. For deleting it, either highlight it with a click and press **Del** on the keyboard or click on the **Cue Delete** button. It can also be deleted from the cue list with a double click.



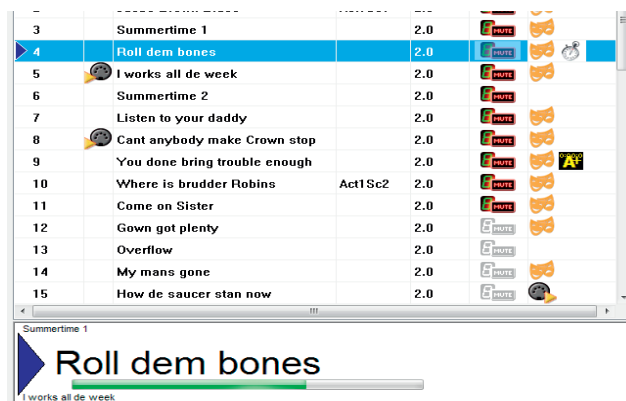

In order to avoid undesired influence by external devices, the **ARM CUELIST** button is used to arm/disarm the cue list inputs. If not armed, the blackout function, MIDI In events, as well as the hardware **NEXT** and **PREVIOUS** keys on the console surface are disabled. Different options for this button can be set in the **Snapshot/Snapshot Automation Options** menu.

Timed Events For a timed event, the time until the next cue is recalled as well as the number of the next recalled cue can be set. When clicking into the corresponding entry field, the recall time can also be adjusted by moving the mouse or the touch pad up/down (range: 0..60 seconds). A progress bar is shown in the large cue area while the timer is running.

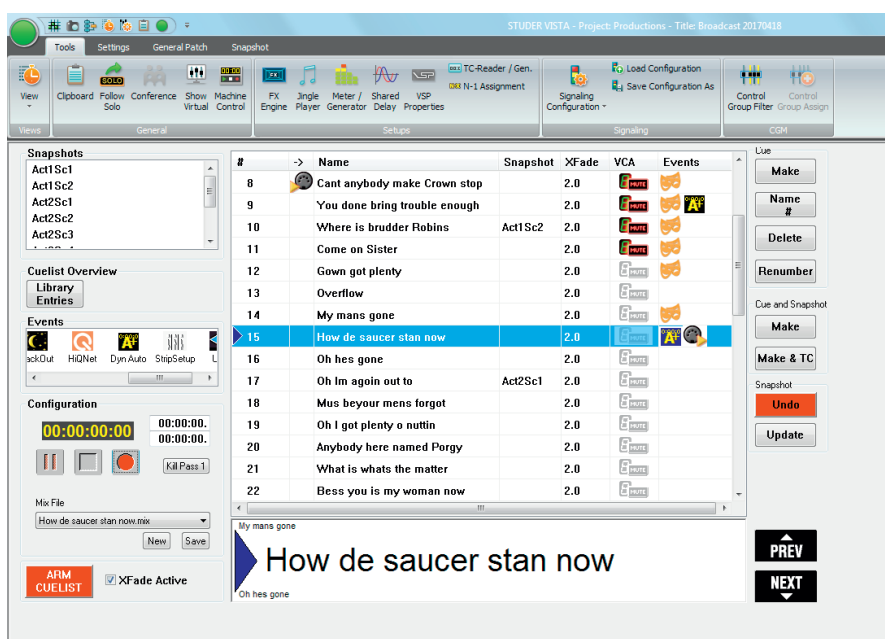

Dynamic Automation Events With dynamic automation events, automatic parameter changes can be inserted into a cue, such as cross-fades, panorama or AUX level changes. Programming such events is very convenient and easy. Dynamic automation events are only used when working with the theatre cue list, therefore the console has to be started in static rather than in dynamic mode. After a click on the Dyn Auto icon in the cue list it is highlighted (blue background), and the Configuration area shows the controls used for the dynamic automation, see below.



For recording, e.g., a fade-in, just click on the  record button. The automation system switches to record-pause mode, the record button's color changes to red , and the  play button is replaced by  pause. Parameter recording is then started either by touching a control (fader or rotary knob), by pressing a key (e.g. **MUTE**), or by a click on the pause button. Once the recording is complete, click on  stop.

The easiest way to record different controls at once (such as for a cross-fade), this is best done on the console. However, since the automation system allows several record passes with different controls, one after the other, a cross-fade can also be recorded with Virtual Vista.

All mix passes are saved, and if the operator is unhappy with the last one (or several of them), he just uses the **Kill Pass x** button in order to delete as many of the mix passes as desired. *Please note that no 'undo' function is available for the Kill Pass x button.*

The cue mix files are saved in the `CueMixFiles` subfolder of the `D950SYSTEM` folder (main D950 projects folder). They follow the same folder structure as the ones of the standard automation mix files and can, of course, be exchanged with them. In other words, any existing automation mix file may be copied into the `CueMixFiles` subfolder of the current production, and vice versa, except that the cue mix files are not saved pass-by-pass.

VCA/Mute Events

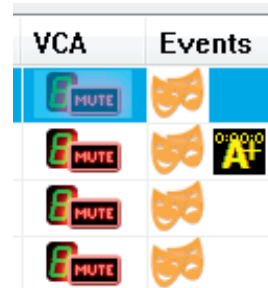
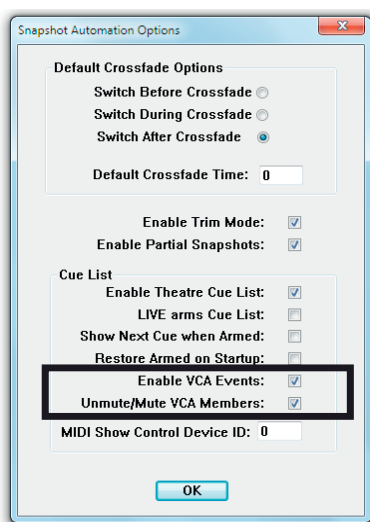

VCA/mute events must be activated in the Snapshot/Snapshot Automation Options window by ticking **Enable VCA Events**, as shown above.

Particularly in large, cue-based musicals, assigning channels to VCA masters provides the basis for the mixing console cue list. It is very easy just to use a small number of VCA masters during the show, reassigning slave channels from cue to cue, instead of working on a very large number of input channels directly.

One of the main tasks when setting up a cue list for a production is assigning the appropriate channels to VCA masters on every single cue. With VCA/mute events this is achieved very easily.

After a double-click on the desired VCA/mute event in the cue list, the VCA details window opens.

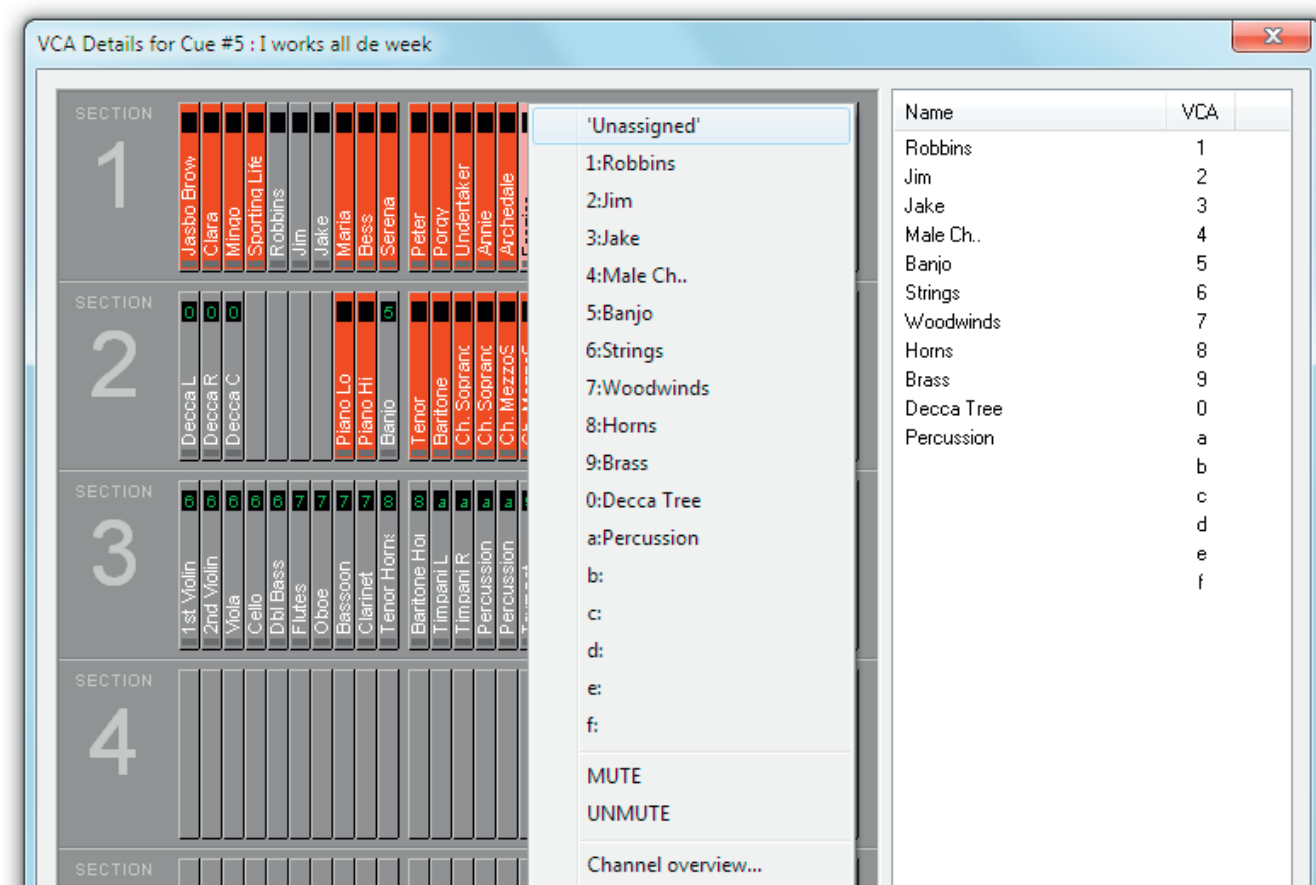

All channels currently muted are indicated in red. The ones being part of a VCA group have the group number in their upper part. When right-clicking on one of the channels, a list with all group assignment possibilities pops up; a channel can also be muted or un-muted without an assignment to a VCA group.

A detailed theatre workflow tutorial is given in [chapter 4.4.5.3](#).

UAD Snapshot Events

From Vista SW version V5.2 onwards, Soundcraft's Real Time Rack Plug-in engine is supported.

To store and recall Real Time Rack effect parameters, an event type called "UAD" has been introduced. By dragging and dropping this event, Real Time Rack-data can be assigned to individual cues.

Every time when a UAD event is dragged to a cue, the Real Time Rack will transmit all data to the Vista desk where the data gets stored into the event as an UAD snapshot.

If a cue with an active UAD event gets fired, all the stored UAD snapshot data will be applied to the Real Time Rack. This includes plug-in type assignment in the 16 channels of the engine as well as all the parameters.

By clicking onto the assigned UAD event of a cue, the Configuration area will show the details.

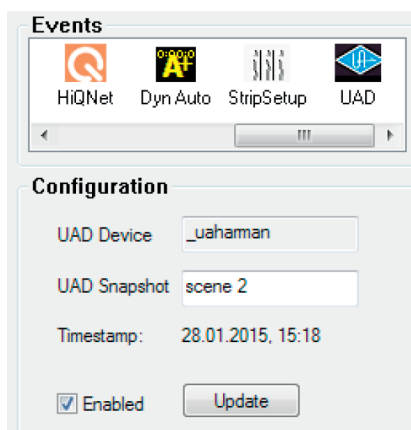

- Rename UAD snapshot The UAD snapshot can be renamed to a more realistic and cue depending name.
- Enable UAD snapshot The **Enabled** checkbox is checked by default after an UAD event is created. By unchecking it, the UAD snapshot will not get executed when the cue is fired.
- Update UAD snapshot Clicking the **Update** button will transfer all the current setting data from the Real Time Rack to the desk, and the UAD snapshot of the currently selected UAD event will be overwritten – the UAD snapshot gets updated.

Note : There is no relation of the UAD snapshots to any kind of console isolation states and filtering.

StripSetup Events Saved StripSetups created in the StripSetup window can be assigned to cues as StripSetup events. By firing the cue, the selected StripSetup gets loaded onto the desk. This is a great feature in rehearsed shows like theatre shows or live broadcast shows, where several different StripSetups are required, to automatically bring the desired channelstrips up onto the desk surface.

Clicking onto the StripSetup cue event icon shows a combo box in the **Configuration** area of the cue list page. This is where you select the desired strip setup file you want loaded for that cue.

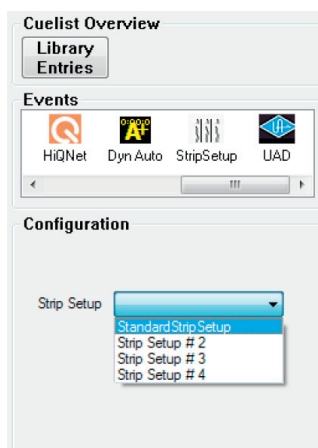

TimeCode Events The TimeCode trigger event allows cues to be fired by a timecode value. When an external timecode is fed to the Vista console, TimeCode trigger events can directly be created with the button **Make & TC - Cue and Snapshot**. The current timecode is then stored as the trigger time for the newly created cue.

Later, when the Cue List is armed, and timecode is running through the same value, this cue will be fired.

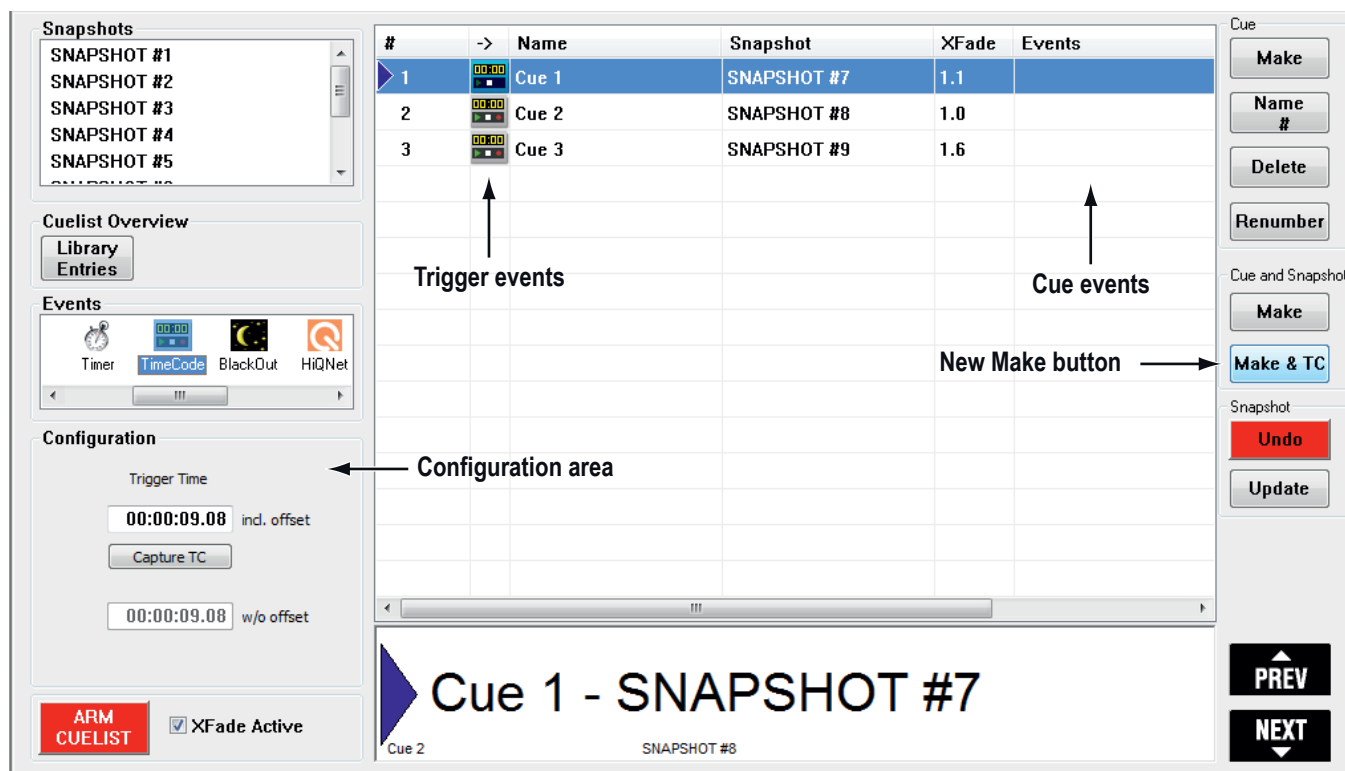

In the Configuration area of the Cue List, the stored timecode value is visible and can also be edited. Editing is very convenient, as numbers can be entered directly, but also clicking on a digit and dragging the trackball up or down allows very quick changes to a timecode value. Also right-clicking onto the event icon allows to shift the timecode trigger value.

In the Ribbon tab Tools, category Setups, opening the “TC Reader/Gen.” dialog, all parameters regarding TC reader can be entered.

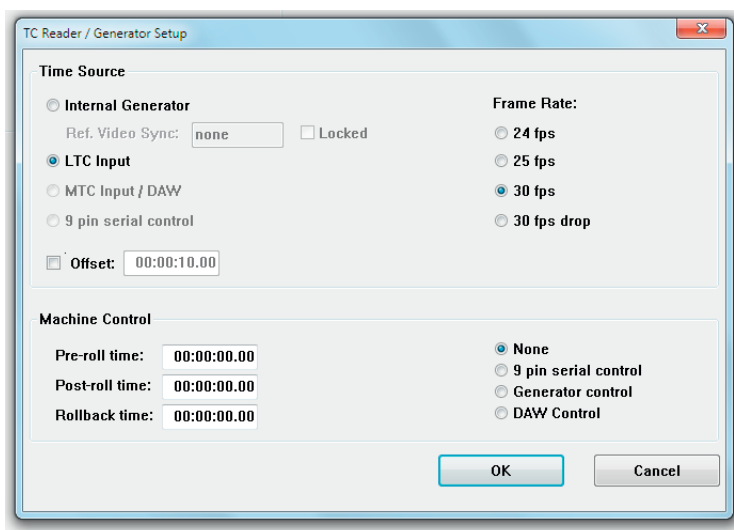

There is also the possibility to enter and activate a global TC “Offset” – this is useful in the case all configured TimeCode trigger events in the whole Cue List need to be shifted up or down against the external TC source.

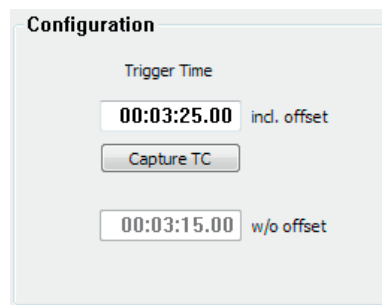

In the Cue List, the upper TC window in the configuration area displays the TC at which the cue will be fired “Trigger Time incl. offset”. The lower window “w/o offset” shows the original TC – the TC value as it was without the introduced offset.

TimeCode events can be deleted from cues as other events – by right-clicking on to the event icon and clicking onto “Delete event”.

4.4.5.2.11 VCA / Channel Mute Mode

A snapshot includes all audio parameters of the console by definition. This means that the sound designer would have to specify for each cue what audio parameters should be masked from snapshot recall, so that only certain parameters change. In most cases however, making changes of VCA assignments, VCA labels, and channel mute status per cue is preferred, rather than working with snapshots in the ‘normal’ sense. Aside from this, the desk has to work in a manual way whereby the operator is not concerned with snapshot recall but only with changes of certain parameters within certain cues. The theatre cue list offers a philosophy that does not only deal with snapshots and attached recall masks per cue, but offers that the snapshots of the VCA/mute and other parameter changes are handled per cue by a library system that stores the parameters.

Please note that the VCA assignment and channel mute parameters are neither saved nor overwritten by snapshots.

This functionality is enabled in the `D950system.ini` file by the system administrator (`[options] - TheatreMode=Yes`).

4.4.5.2.12 Isolate Labels and VCA Assignment

In order to allow label changes being copied into several snapshots (by recalling and updating snapshots) they need to be able being isolated on an input port-by-input port basis. This is done with the  isolate button next to the user label button in the general patch page; if isolation is active, the button is highlighted in yellow.

Isolated User Label

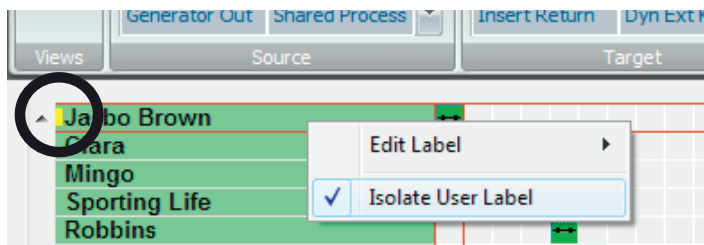

The VCA assigns need to be able to being isolated as well. The VCA assign isolation can also be done on the input channel side, individually channel-per-channel. This is done in the channel patch page.

Isolated VCA Assignment

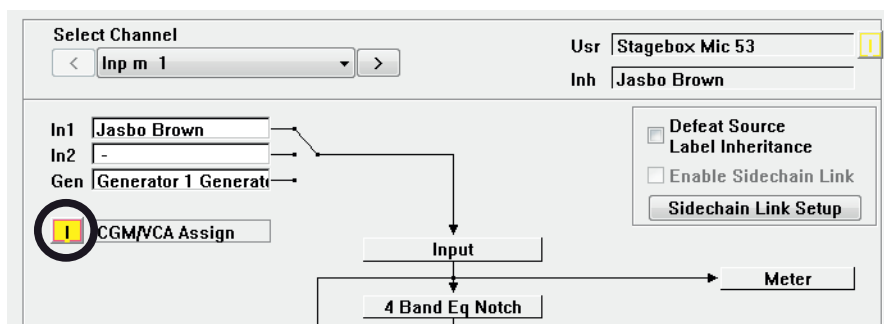

Isolated VCA User Label

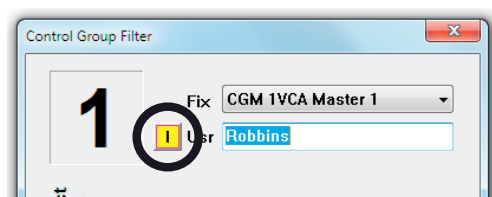

4.4.5.2.13 Mute Groups

In theatre mode, the mute groups are fully independent from snapshots and VCA/mute events. Mute group mutes will neither be saved in the snapshots in this case, nor will they be overwritten by a snapshot recall.

4.4.5.2.14 Hard Mute

‘Hard mute’ is an additional mute status. It can be used in the same way as a mute group, but doesn’t need a mute group setup and has, in particular, top priority over any other programmed mutes. This means that a hard mute is fully independent of what is recalled via a snapshot, a VCA/mute event or a mute group. It can be applied to every desired channel at any time, making sure that no audio is passing through this/these channel(s). Its main purpose is solving problems with a channel, if, e.g., a wireless microphone is defective.

In order to set up a hard mute, first the corresponding option needs to be activated. In the Ribbon tab **Settings** category **System**, opening the “Vista Settings.” window. Select the **Misc** tab and tick the **Live mode activates Hard Mute** entry.

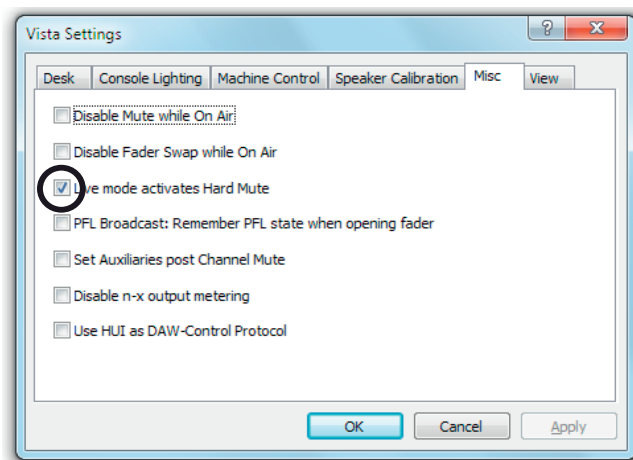

A click on the **LIVE** button (or pressing the small **LIVE** key in the desk’s **CONTROL ROOM** monitor section) followed by a channel **MUTE** button activates a hard mute of this channel, regardless whether this channel is currently muted or not. If a channel is hard-muted, a **HARD MUTE** indicator appears in the Vistonics label area, and the **MUTE** button is illuminated.

If a hard mute is applied to a channel that already has a ‘soft mute’ caused either by the system (via a snapshot or a VCA/mute event) or manually with the **MUTE** button, this is indicated by illuminating the **MUTE** button together with the small **MUTE** LED, as shown below.

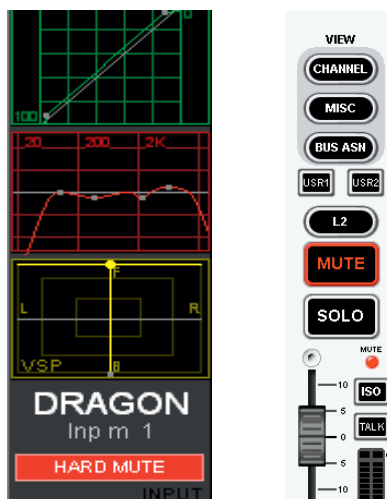

4.4.5.2.15 Cue List Options Menu

In the Ribbon tab **Snapshot**, category **Options**, in the ‘Snapshot Automation Options’ menu, the following options are available:

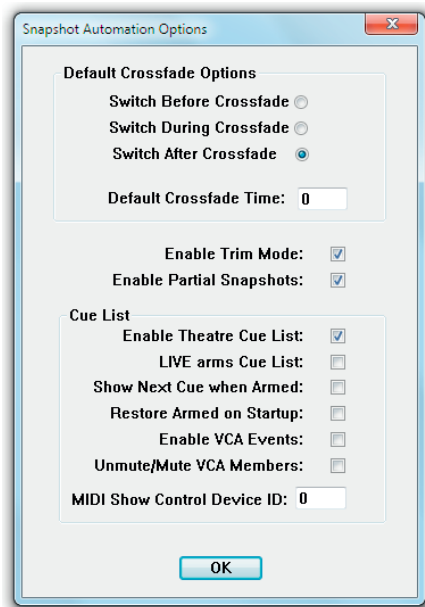

Default Crossfade Options

The system allows cross-fading between two cues. The default cross-fade values may be defined here. These will be used whenever a cue is created.

Switch Options

Describes the behavior of switches (e.g. **MUTE**, **EQ** on/off etc.) during a cross-fade. They apply if a switch changes its state in the next cue. They may change their state before, during, or after the cross-fade.

Default Crossfade Time

Set default value of cross-fades when new cues are created (enter in seconds).

Enable Trim Mode

When pressing-and-holding the **ISO** key on the channel strip followed by touching individual controls (e.g. faders, rotaries), their state can be isolated from snapshot recalls. If this option is on, the particular parameter may be touched a second time. This will set it into Trim mode. In this mode all changes to that parameter since the last snapshot recall will be applied relative (!) to all upcoming snapshot recalls – thus, not modifying them on disk.

Enable Partial Snapshots

Activates the ‘Partial snapshot’ feature. It will be possible to include only ganged channels when making a snapshot. Options are available within the snapshot window of the GC screen.

Cue List

Enable Theatre Cue List

Enables extensive functionality of cue lists.

ONAIR arms Cue List

When pressing **LIVE** in the **EXT PFL SPEAKER** area of the Vista 8 control bay, the state of the cue list will change accordingly.

Show Next Cue when Armed

Defines whether the currently active or the next cue should be highlighted when the cue list is armed. This also allows reading the attached notes ahead during the live event.

Restore Armed on Startup

The system will switch the console into the ‘armed’ state whenever the software is started. This allows e.g. constant reception of external MIDI commands for firing off cues.

Enable VCA Events

See [chapter 4.4.5.2.10](#).

Unmute/Mute VCA Members

See [chapter 4.4.5.2.11](#).

MIDI Show Control Device ID

See [chapter 4.4.5.2.8](#).

4.4.5.3 Theatre Workflow Tutorial

		In general, a cue-based production usually has a workflow similar to the following scenario:
1.	Console Setup	The channels are labeled, patch connections are made, etc.
2.	Building Cues	With the help of the script, the cues are created and named. VCAs are labeled and channels are assigned to VCAs. Mutes are made (per cue).
3.	Rehearsal Phase	This is the first time that the cast is involved. No orchestra yet, just a piano. Mic gains and EQs are set, but only in a hurry, since rehearsals go fast (through all cues). With more rehearsals, the mic gain and EQ settings get refined. Cues need to be added.
4.	Dress Rehearsal Phase	This is the first time that the orchestra/band is involved. These channels can now be setup (gain, EQ, monitor mix). Now with dresses, props and orchestra, vocals sound different; mic gains and EQs need to be refined.
5.	Preview Rehearsal Phase	This is the first time that an audience is involved. Things sound different again since the audience modifies the acoustics of the venue. Fader levels, gains and EQs need to be adapted.
6.	Shows	During the show, the console operator reads the script, goes from cue to cue and rides VCA master levels. Usually there is no time available for changing parameters apart from the VCA levels. Basically, the channel settings don't change anymore, but it may happen anyway (almost every show) that an actor or a musician of the orchestra needs to be replaced due to sickness or other reasons. This means that channel settings such as mic gain, EQ and dynamics need to be adapted to the current understudy actor; this is, however, only required for the corresponding input channels.
Glossary:	Character / Role	The name or term of the character or role in the script, such as Romeo, Julia, etc. It is very important to understand that one input channel of the console should always be fed with the mic signal of one certain character/role throughout the whole play.
	Actor	Name of the person who is playing a specific character/role.
	Understudy	Actor who replaces the main actor in case of sickness, different shifts, etc.
	Cast	The ensemble/company, i.e. all (or several) actors or all actors of a play.

Conventions for the Workflow Suggested Below:

- An input channel of the console is equal to a character of the play.
E.g. Inp m1 = Romeo; Inp m2 = Julia, etc.
- When the role of Romeo is played by an actor called John Smith, an actor for Romeo's role (Inp m1) needs to be created whose name is John Smith.
- Later on, an understudy actor can be created as a copy of John Smith but with the actual understudy's name.

4.4.5.3.1 Console Setup

Tip: Always work with active device labels (Ribbon tab Settings, category Device Labels) Use Device Labels, and Overwrite Chan. User Label with Device Label must be active.

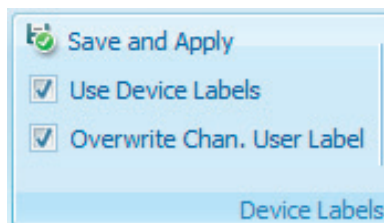

In this phase, all the necessary console setup work is made. No actors or musicians need to be on stage. Therefore this setup phase can also be done with Virtual Vista without having the physical console available.

- Select one from the ready-made configurations (see [chapters 2.1.5](#) and [6](#)) the one that is best suited for your needs, and create appropriate project and title names for the particular production.
- Do the labeling of interfaces (device labels).
- Create patch points – from interfaces to input channels, from output channels to output interfaces, as well as every other patch connection that is needed (e.g. shared processes).
- Add the user labels to the input interfaces, i.e., the labels of the characters of the play.

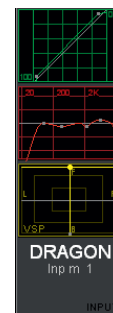
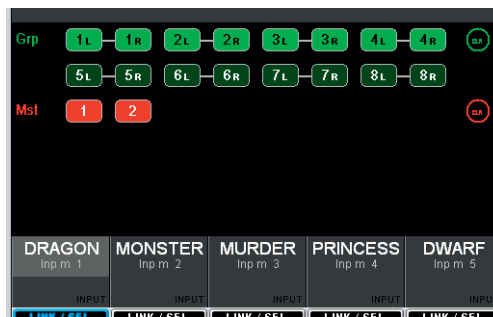
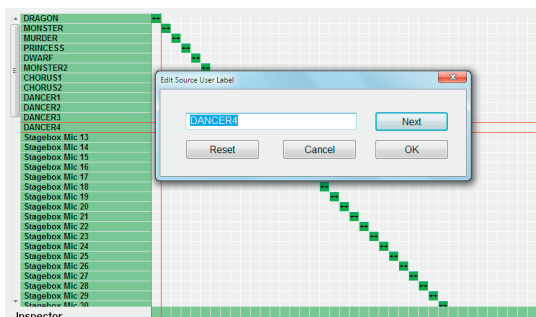

- Create a strip setup.
- Do the bus assignment as required for the particular production.
- Save this in a 'basic settings' snapshot or preset.

4.4.5.3.2 Building Cues

Cues can be built on the Virtual Vista. When the rehearsals begin at a later stage, the title needs to be transferred to the ‘real’ console. Depending on the time available, cues may, of course, be built on the ‘real’ console directly. In both cases the goal is having audio as soon as it is needed for the first rehearsals.

Creating Actors Since the library events are sorted in the channel settings library by actor names, consider entering their real names, if they are already available at this stage. Having all the names already entered in the library ready to use and to save settings with it would be a good preparatory step. It may also be done later, however.

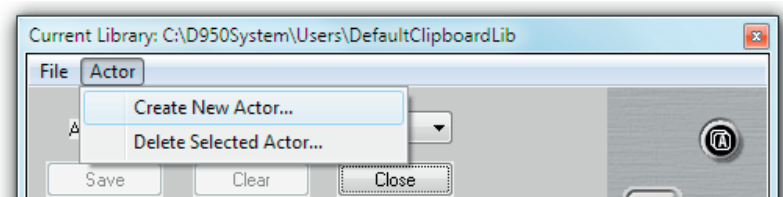

Creating Cues This is the next step. It is usually done according to the script. The best way to do this is creating and naming all cues used for the play.

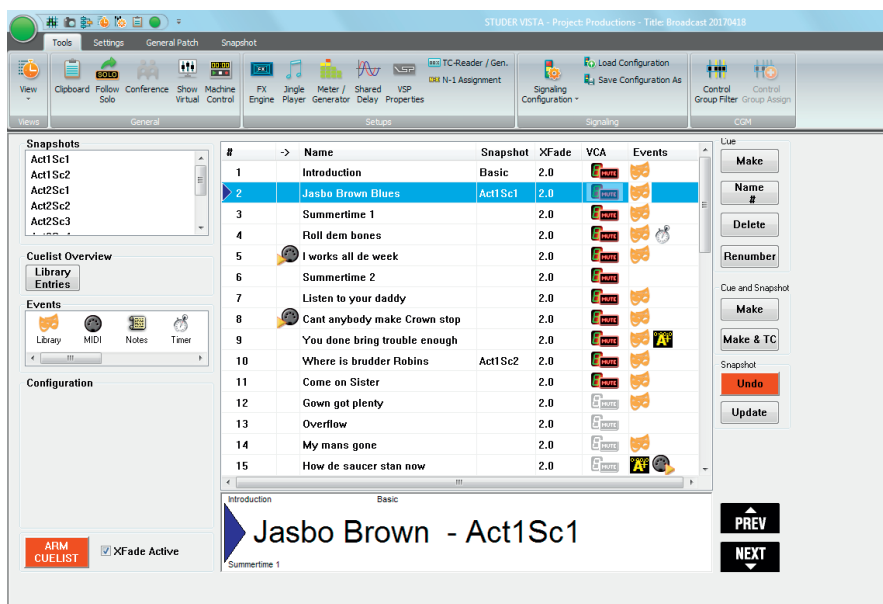

In the process, the Cue **Make** and Cue **Renumber** functionalities can be used in order to build and update the cue list until it is complete. This phase may last throughout several rehearsal stages.

Tip In order to be able later to make efficient use of library events, it is recommended that the first cue of a show has a snapshot attached, making sure that the console is in a 100% defined state at the beginning of the show. This would be the ‘basic settings’ snapshot created during console setup. Since the library and the VCA/mute events are completely separate from snapshots, the console’s basic settings remain static for all channels for which no library events are used throughout the whole show. Adjusting any static parameters of the console and overwriting the ‘basic settings’ snapshot is an

easy way of updating the static settings, without affecting or overwriting the changes that are caused through the VCA/mute and library events on a cue-by-cue basis.

VCA Master and Mute Setup

Along with the cues, it is very likely that input channels are grouped and assigned to VCA master faders. The setup is done in a very efficient way using VCA/mute events . The whole setup process is done in one single window. Normally, the channels that are not used in a cue need to be muted, in order to avoid that an actor who still wears his wireless microphone backstage while he is e.g. changing his costume can be heard over the PA system. Therefore, all channels not assigned to a VCA master are muted automatically if the **Unmute/Mute VCA Members** option is ticked in the 'Snapshot Automation Options' menu, as shown below.

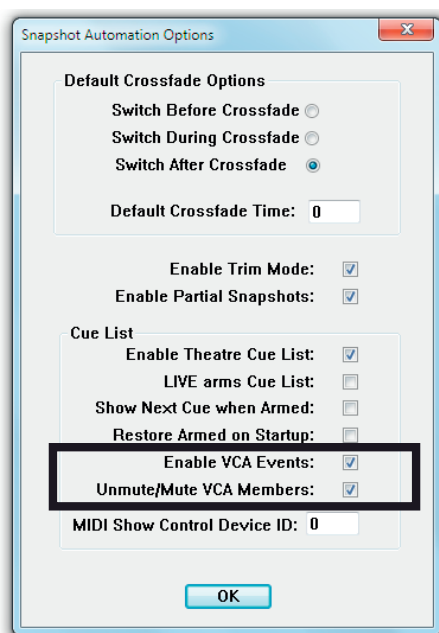

Either a double-click on the VCA/mute icon  or a single click on the VCA/mute icon followed by a click on the **Edit VCA assignments...** button (at the bottom of the Configuration area) opens the VCA Details window. It looks very similar to the strip setup window. Muted channels are shown in red, and the small digit at the upper end of every channel indicates to which VCA master this channel is currently assigned. By right-clicking on a name a history window is shown that lists the VCA names already used within the current production.

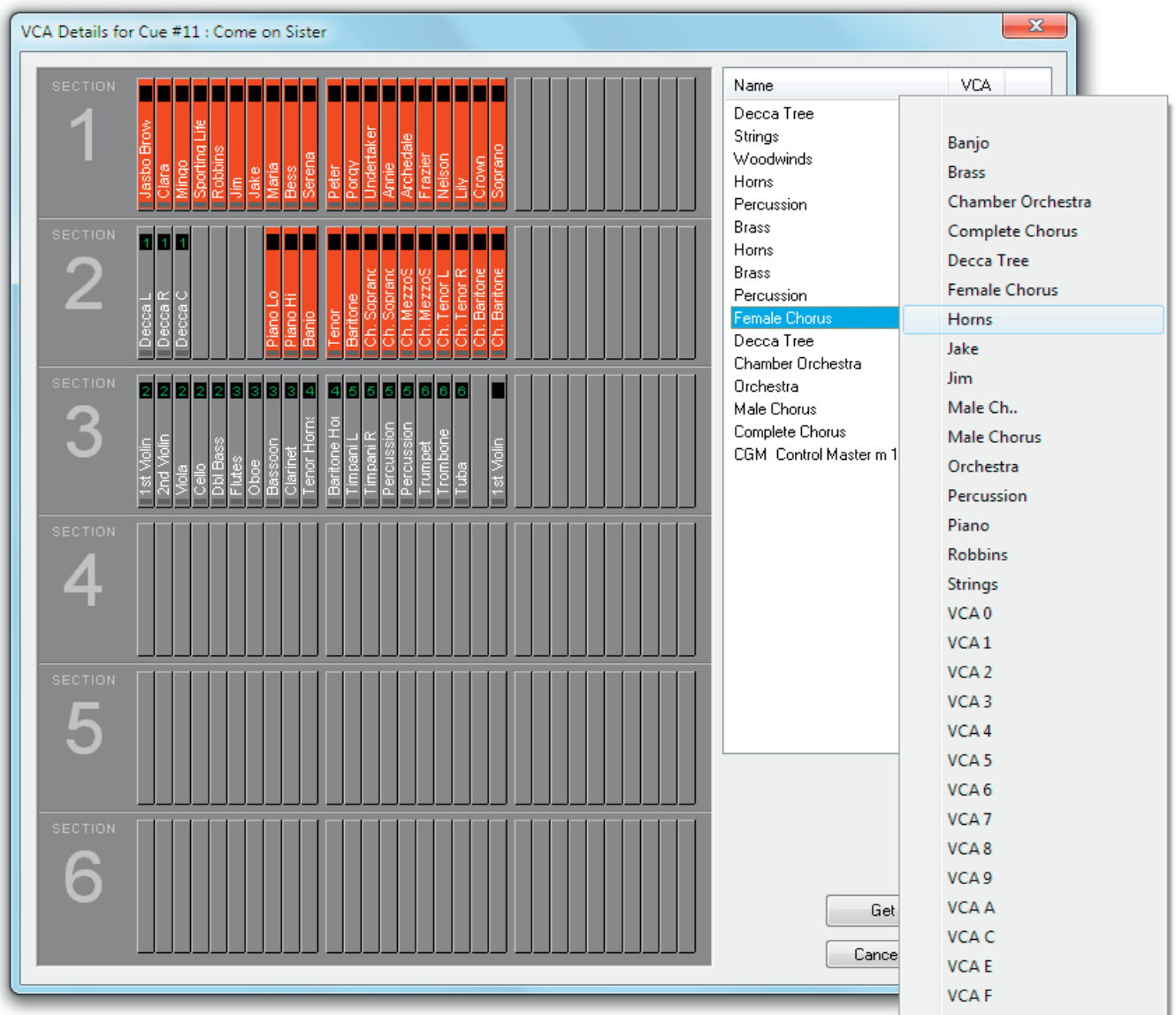

A right-click on the VCA/mute event icon of the current cue (i.e., the one that is currently highlighted) allows copying/pasting the VCA/mute settings from the current cue to a different one (that must be made the current cue, i.e. highlighted, before pasting).

Please note that the VCA/mute event settings of the current cue are copied and applied whenever a new cue is created. Then, the VCA/mute event icon is grayed-out , indicating that this cue's VCA/mute event settings are identical to the one in the cue immediately before.

Alternatively, the mute setup can also be done on the desk with the MUTE keys of the desired channels. The update in the current VCA/mute event is then done by opening the VCA Details window and using the Get Current Settings button at its bottom.

4.4.5.3.3 Rehearsal Phase

Once the basic settings are transferred to and saved within the console and the rehearsals are at a stage where the original cast is rehearsing, e.g. already in costumes and with the stage props, the cue list can be completed with library events where necessary.

Library Events

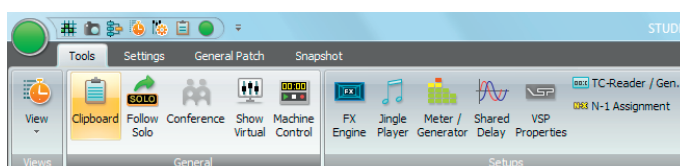

Library events can be used to make the necessary parameter changes on a cue-by-cue basis, without the need of using snapshots to accomplish these changes. This makes the workflow easier, faster and more straightforward, allowing the operator focusing on the mix, rather than having to remember appropriate snapshot and snapshot filter states.

Library event settings are visible in the clipboard library window that is opened with a click on the Clipboard library icon :







The collected settings are organized in such a way that a setting or a number of settings belong to a particular actor. Just select the desired actor from the Actor drop-down list to display his settings.

If the Actors have not been created already, they can also be created on the fly, together with the actual library event settings by copying them from a channel strip. To do this, proceed as outlined below.

- Go to the desired channel strip on the desk surface and copy the current setting of the desired processing block (or a combination of several processing blocks – PAN, EQ, DYN, INS/DEL, FILT, or ALL parameters of a channel at once) with the  or  keys.
- Paste it into the library under the desired actor. If the actor does not yet exist, it can be created while the copied parameters remain in the temporary clipboard.
- While being pasted into the library under an actor, the setting needs to be given a name. The naming of the setting is important, since later on only the names of the settings are shown on the Vistonics screen, and the operator needs to be able to select to appropriate setting just from reading the name.
- Once a setting is saved in the library, it still needs to be applied to the desired cue(s). For this purpose, the identification concept uses the names of the library settings.

Add a Library Event to a Cue

First, select the actors view on the Vistonics screen by pressing the  (Shift) and  (INPUT) keys. This is a global actor view across all Vistonics channels; a particular actor is also shown when opening the channel view using the  key.

With a right-click in the Events column of a cue and selecting the library event  symbol from the list that drops down, a library event is added to that cue. An alternative way to do this is by dragging-and-dropping the library event symbol from the Events area at the left of the cue list into the Events column of the desired cue.

By clicking on the icon once, the Configuration area opens in the lower left

corner of the cuelist page. When right-clicking in this area, channels (i.e., characters), actors and library entries can be selected.

If the desired library setting has already been added to the actors' library, it can be dialed up with the Setting Vistonics rotary and applied to that specific channel in the current cue with the Apply key. If there are no other library events further down the cue list, the applied library setting will remain active in the channel through to the end of the cue list. If other library events have already been applied to cues further down in the play, the new applied setting will only be applied from the current cue to the one right before the cue where the next library event is active.

Actor Overview... Window

An overview window of all library events throughout all cues and all channels is shown by a click on the Actor Overview... button. In this window the names of all entries are shown per cue. When right-clicking in this window, the entries can be changed, and further entries can be added.

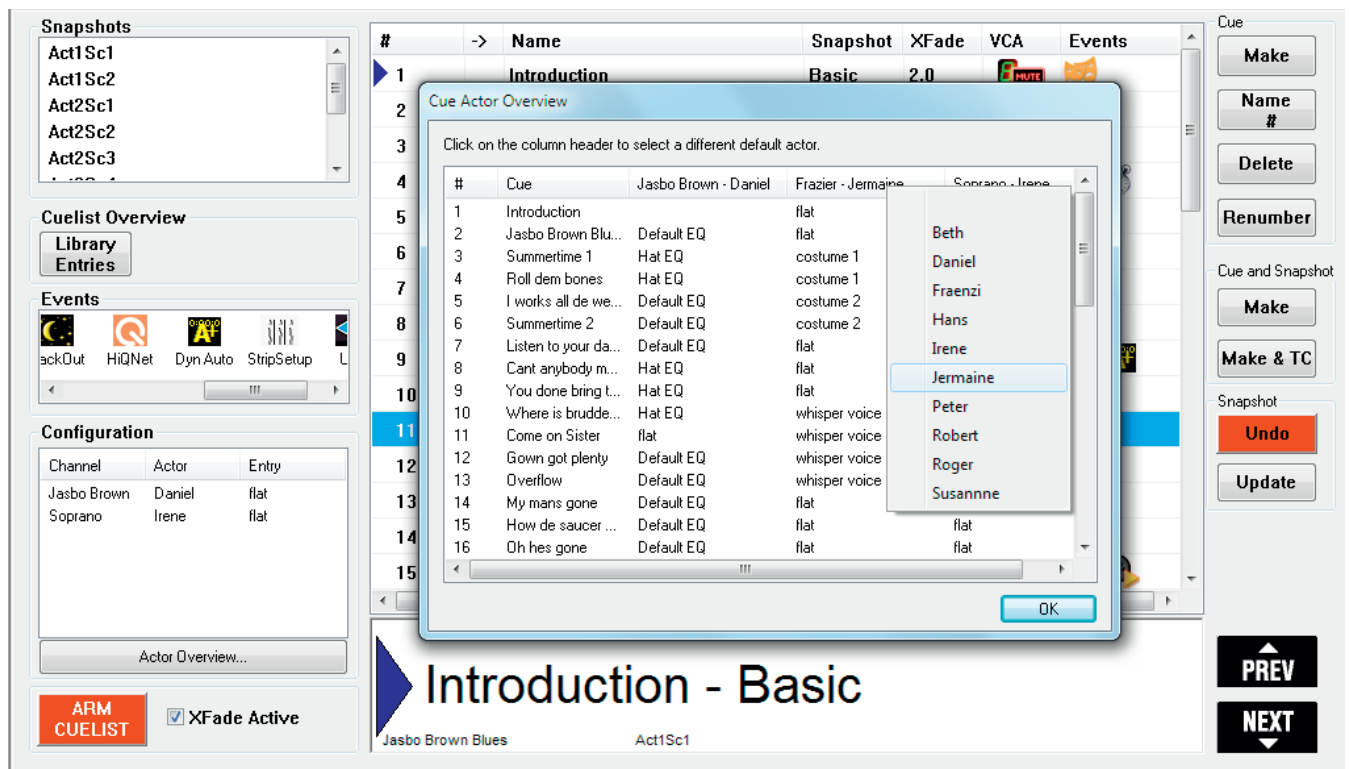

Other Events

During the different phases of rehearsing, other events can be added to the cues as well:



MIDI

MIDI program changes, note-on, note-off and MMC (MIDI machine control) commands are available from the Configuration area once a MIDI event has been added.









Notes

Plain notes,



BlackOut

blackout events,

 Timer	timed cue events,
 Dyn Auto	dynamic automation events,
 HiQNet	HiQNet events,
 UAD	UAD events, and
 StripSetup	StripSetup events, and
 TimeCode	TimeCode events are available as well.

For detailed descriptions of each event type, please refer to chapter [4.4.5.2.10](#)

Shows

Tweaks During the performances, all console parameters can be tweaked. If these are static parameters (settings that remain constant throughout the whole show) and there is only one single ‘basic setting’ snapshot at the very beginning of the cue list, they remain with the same tweaked value until the end of the show.

If the changes should be kept for future shows, all these values can be updated simply by updating the ‘basic setting’ snapshot in the first cue.

Parameters that have been pasted into a channel from the channel setting library (i.e., library events) can be tweaked as well, and the changes are automatically transferred to all the cues where the same setting is used. The library event’s name in the clipboard library list and on the Vistonics channel view – such as **Hat EQ** – will then change to **Hat EQ***, with the ‘*’ (asterisk) signifying that it is different from its original setting. On the Vistonics channel view a **Revert** button is added. Pressing it will discard the changed library setting and bring it back to its original value.

If however such a changed parameter should be conserved and updated in the library while keeping its original name, the **Save** button must be pressed.

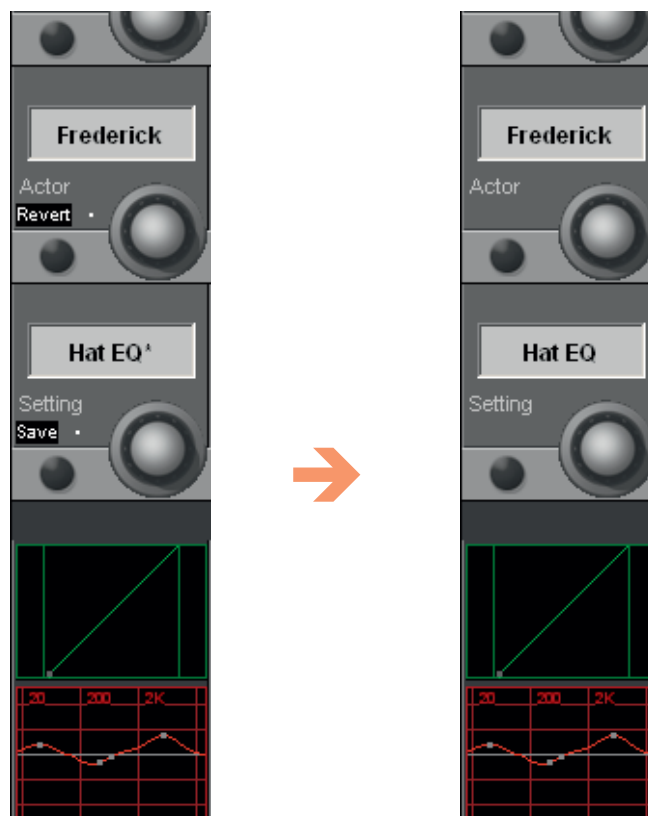

Understudy Settings With the repeated performance of a play, replacement actors (also called understudies) need to be considered. They will take over in case the main actor should get sick, or simply because shifts are introduced. New actors can be entered into the library just by making copies of existing actors, followed by modifying the individual settings of the understudies.

In the **Cue Actor Overview** window, the default actor can easily be replaced by a simple click on the ‘character - name’ bar and selecting the replacement from the drop-down list. All library settings will then automatically be replaced by the ones of the understudy actor.

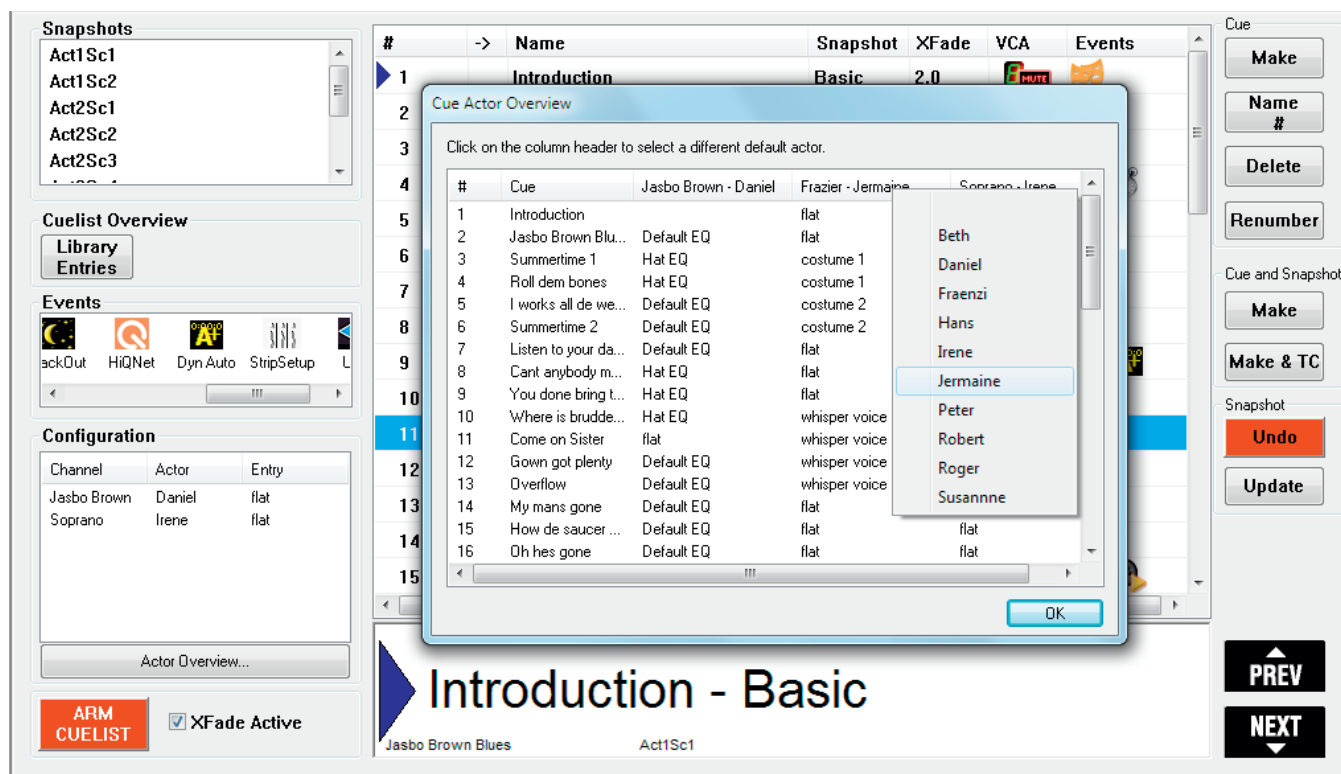

End Show Button There is an End Show button at the bottom of the clipboard library window. It is intended to be used at the end of a show performance, as the name implies.

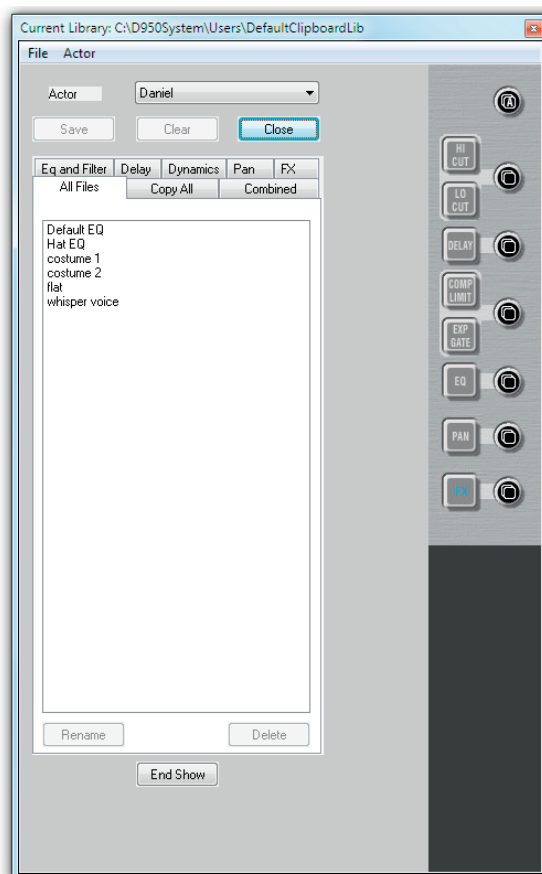

This button opens a list that displays all tweaked library event settings. It prompts the operator to decide whether he wants to save or discard these tweaks, either globally or setting by setting.

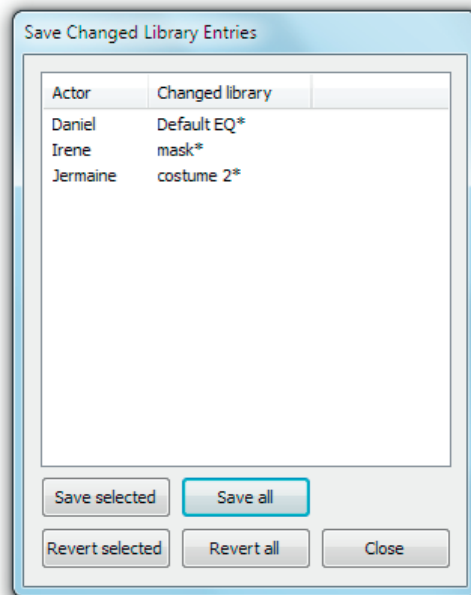

The End Show mechanism simply makes sure that no tweaked setting can be forgotten to be either discarded or kept. It may, of course, also be used during a show or a rehearsal in order to clean up the current changes.

If there are any tweaked settings or modified mute events that have not been saved already, there will appear a dialog box upon closing the clipboard library window, asking the user whether he wants to save the unsaved data. So again, no setting can be forgotten even if there is pressure of time.

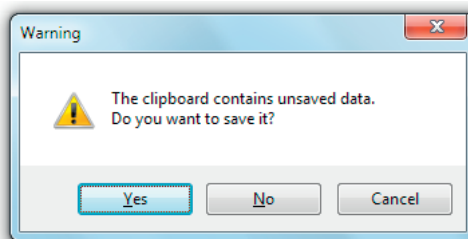

Also if the Vista application is closed down after the show and tweaked settings had not been saved, again the list that displays all tweaked library event settings is opened and prompts the operator to save or revert the changed settings.

4.4.6 Strip Setup

The Strip setup page can be called up in three different ways:

- From the Page menu
- Using the page Icons
- Using the **STRIP SETUP** function key in the Control Bay of the Vista surface.

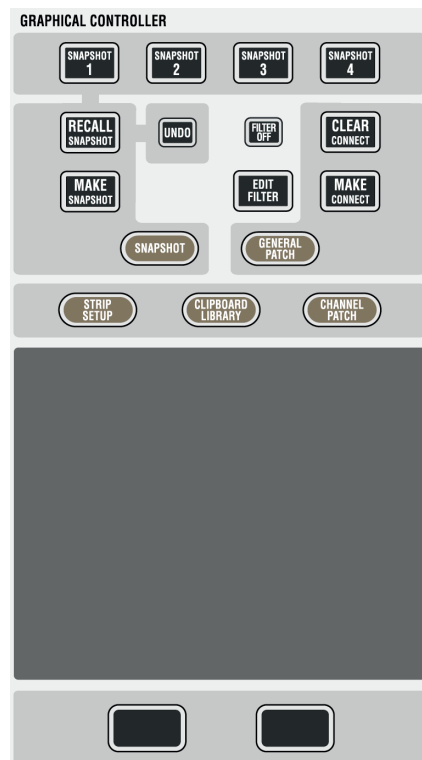

The Strip Setup page has a number of functions. Primarily, the ‘Strip Setup’ window allows the user to assign DSP Channels onto the Vista surface. It also gives a very good overview of the console and may be used during general operation of the console to help the user navigate around the console.

Please refer to [chapter 1.1.5](#) for information on navigation philosophy.

The Strip Setup page (see below) provides a representation of the six sections of the Vista ‘virtual surface’. Although the concept of navigation is based on scrolling in a horizontal plane, the representation of the six sections is displayed in a vertical plane because of screen space. The navigation system allows the user to decide which area of the virtual console the Control Surface will represent. The number of bays within a section will automatically be identical to the number of physical bays of the control surface. In the example shown below, the Control Surface will have three fader bays – a total of 30 faders. The total number of virtual channel strips available to represent DSP channels is $6 \times 30 = 180$ in this example.

Color Code Color is applied to aid the user in channel identification. The colors relate to the channel type being shown. These are consistent with the use of color for channel identification on the Vistonics screens.

Slow Channel Meters On the Strip Setup page there is also a representation of the channel meters, giving a (slow) overview of all input signals. Channel assignment corresponds 1:1 to the desk fader channels.

FaderGlow Colors As a thin frame around a channel strip, the FaderGlow color is also displayed in the Strip Setup.

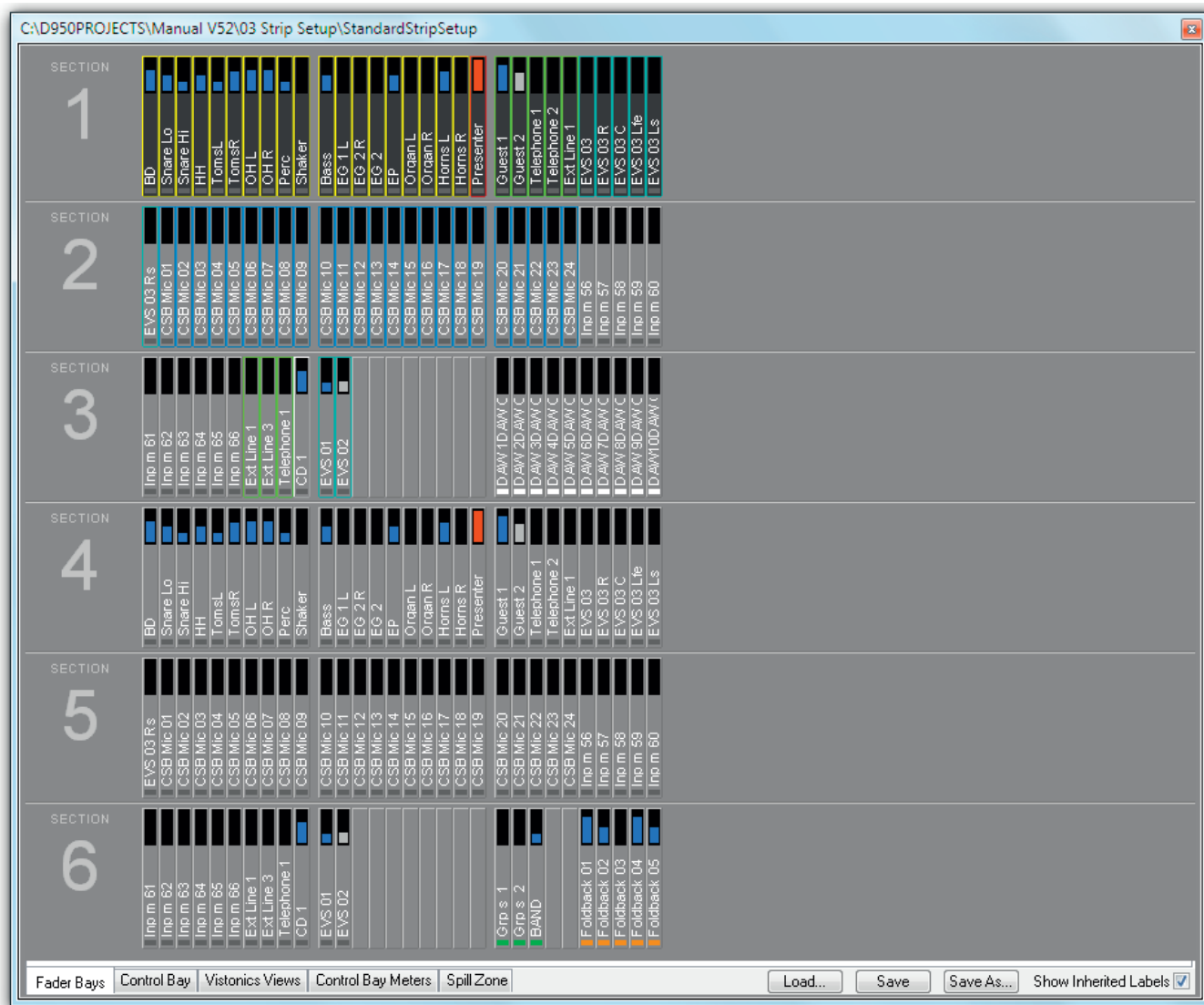

4.4.6.1 How to Use the Strip Setup

To create a new strip setup or to adapt an existing strip setup, first call up the strip setup page (see above).

4.4.6.1.1 Assigning a Single DSP Channel to a Single Channel Strip

To assign a channel to one of the virtual channel strips, right-click on the virtual channel strip that the DSP channel is to be displayed on. This will highlight the chosen channel and a selection menu will appear, listing all the categories of channel types. These are submenus that contain a list of the available DSP channels in the currently loaded configuration. Move the cursor to the drop-down menu of the desired channel type and select the desired channel from the list to assign it to the highlighted channel strip.

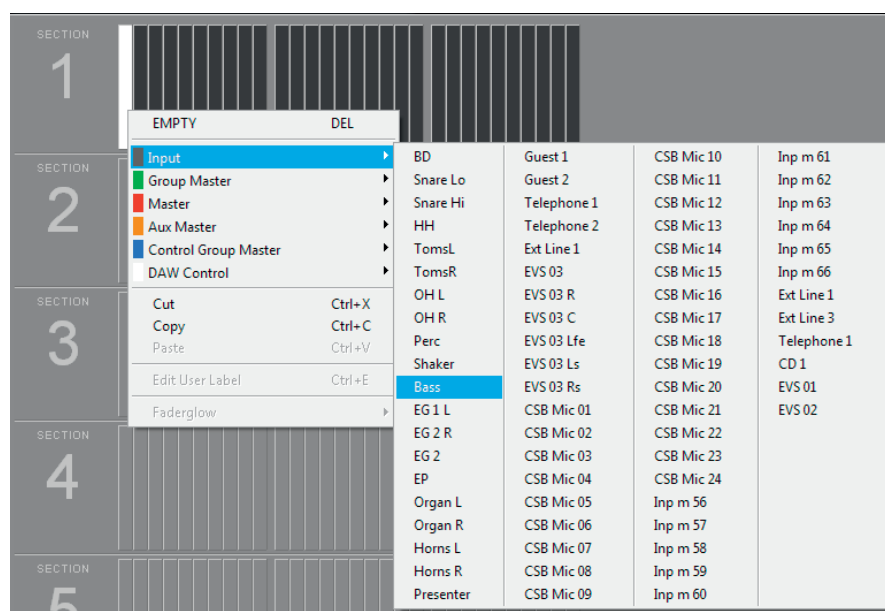

4.4.6.1.2 Assigning Multiple Channels in one Single Action

It is possible to assign consecutive DSP channels onto consecutive channel strips in one action. First use the hold and drag function of windows to select a number of consecutive channel strips. This will highlight the selected channel strips. Right-click on any of the highlighted channels to open the channel selector menus. Select the first channel of the consecutive channels to be assigned. Consecutive DSP Channels will now be pasted to fill the number of highlighted strips.

Tip By double-clicking on a single channel, the complete bay of 10 strips that the channel strip resides is selected. Three clicks on a single channel will select all channel strips within the complete Section.

4.4.6.1.3 Moving Already Assigned DSP Channels to Other Channel Strips

If a DSP channel is already assigned to a channel strip, it is extremely easy to change the channel strip on which it is shown. Simply click-and-hold the left touch pad button on the desired channel and drag-and-drop it onto any other channel strip. This will remove it from its present position and place it in the new channel strip. Whilst the left touch pad button is held with a selected channel, a ‘ghost’ view will appear to aid navigation to its newly selected channel strip. If it is dropped onto a channel strip which is already displaying a channel, the new channel will replace the existing one.



It is also possible to move numerous consecutive channels in one block by highlighting a number of channels. Click-and-hold the left touch pad button and drag-and-drop the channels to the new location. A ‘ghost’ view of the selected channels appears to help navigation.



Tips By holding the **Ctrl** key whilst dragging-and-dropping channels, the DSP channels will be copied to the selected destination, instead of being moved from their original position. Standard Windows copy/paste functionality (Ctrl+x for cutting, Ctrl+c for copying, Ctrl+v for pasting) is possible once channel strips are highlighted.

Note: If ten channel strips are copied or cut, and only five channel strips are highlighted to paste the DSP Channels into, then only the first five DSP channels of the copied ten will be pasted.

4.4.6.1.4 Useful Information

- Any DSP Channel can be assigned to any Channel Strip on the virtual control surface.
- Any DSP Channel can be assigned more than once to several different Channel Strips on any Section.
- It is not necessary to assign all DSP Channels available in the currently loaded configuration; then, however, there will be no control of these channels from the control surface.
- Assigning DSP Channels to Channel Strips has no affect on audio. It is purely a viewing function, and therefore changing the strip setup can be done at any time whilst operating the console.
- An indication is provided to highlight which bays are currently displayed on the physical console. These displayed bays are in dark gray.

4.4.6.1.5 Labels in Strip Setup

The most useful label type to show in strip setup is the ‘Inherited Label’. This is the session label of the source that is patched to a DSP channel and also relates to the large label in the channel strip display. See [chapter 4.4.2.6](#) for more information regarding the Vista labeling system. For this reason, a checkbox is provided which locks the label type view of Strip Setup to show the ‘Inherited labels’ (see below). Check the ‘Show Inherited Labels’ box to always show Inherited Labels in the Strip Setup window.

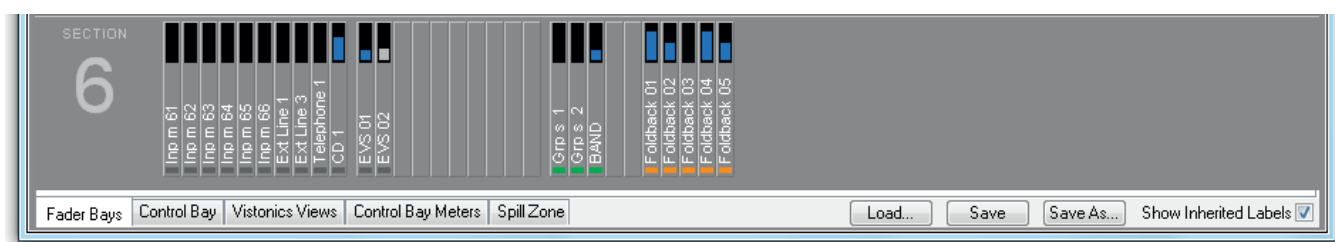

If the ‘Show Inherited Labels’ box is not checked, the label type shown in the Strip Setup will follow the choice of the label displayed by the smaller label in the Channel Strips. See [chapter 4.4.2.6](#) for a description of this label.

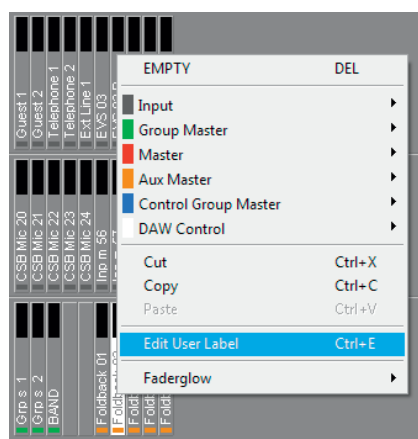

The following channel types can directly be labeled in the Strip Setup by right-clicking the desired channel, and then selecting Edit User Label.

- DAW channels
- CGM/VCA masters
- Aux masters
- Matrix masters
- Group masters
- Masters

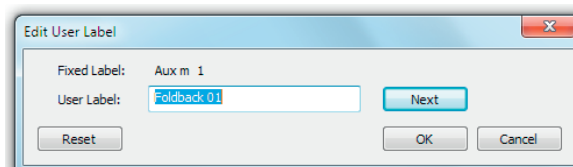

Important

Input channels are the only channels that cannot be labeled in the strip setup. This is because the input channels use a special mechanism always propagating the name of the Input interface (e.g. mic input) to the channel patched to

this particular interface. This is very helpful since the user names need not be relabeled whenever the patch is changed.

Therefore, it is of no use when manually changing the user label of an input channel – it will always get overwritten automatically.

4.4.6.1.6 Metering (the TFT Meterbridge is optional for the 32 fader Vista 1)

Strip Setup Window

If the ‘Fader Bays’ or ‘Control Bay’ tab is active, every channel displayed on the console surface also has a *slow* meter in the strip setup window that is a slow indication of signal activity at this channel’s input. Color is used to identify the channel’s status. A blue meter bar means that the channel has its fader open and is switched on. If the meter bar is gray, then the channel has a signal associated with it, but either the channel fader is closed or the channel is muted (off). If the meter bar is red, the channel currently is in overload status.

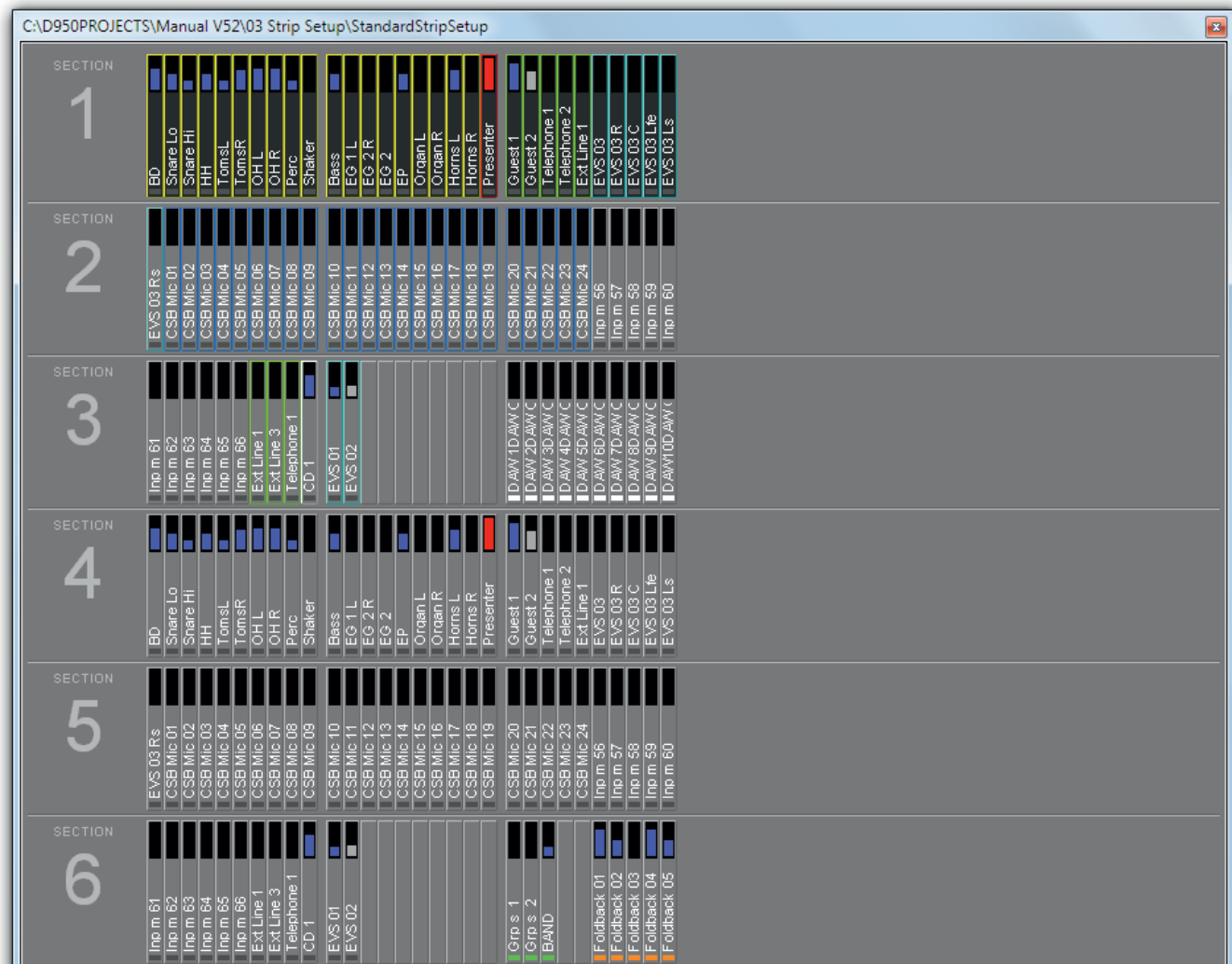

Fader Bay Meters The default assignment of the TFT meters to the fader channel strips is 1:1. This may be modified by the system administrator only; if not logged in as system administrator, the ‘Fader Bay Meters’ tab is not displayed, and meter assignment is restricted to the control bay.

Assignment is done in the strip setup window. First, click the ‘Fader Bay Meters’ tab. The window changes to the view shown below. Entering channels is done with the same mechanism as is used for the assignment of channels to bays.

Changes in the channel assignment may be easily reset to the default setting by selecting ‘Reset to StripAssignment’.

Lower Meter Area The default settings of the lower meter area are labeled ‘DEF’. These are the history view for mono and stereo channels, and the surround view for 5.1 channels.

When right-clicking into the lower meter area, the display mode of the lower part of the meter can be selected (‘HIST’ for the history display, ‘BUS’ for bus assignment view, ‘SRND’ for surround view, and ‘L2’ for layer 2 view). Options not available for a particular channel type will be grayed-out.

Changes made here may also be reset to the default setting by selecting ‘Reset to StripAssignment’ after a right-click in the upper meter area.

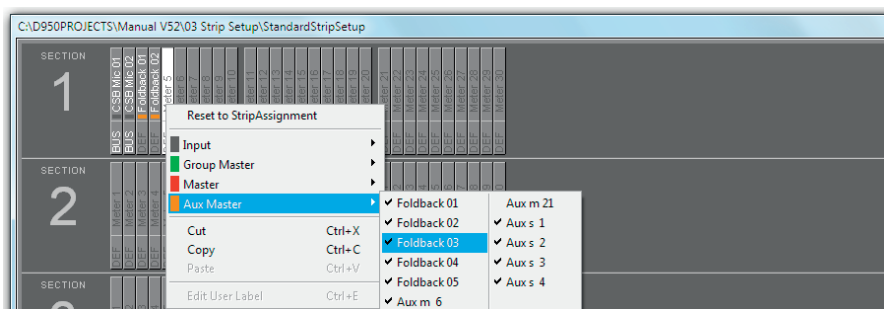

Control Bay Meters Click on the ‘Control Bay Meters’ tab. The window changes to the view shown below. Entering channels is done with the same mechanism as is used for the assignment of channels to bays.

After selecting one of the ‘USER’ fields, the view corresponding to the user keys can be defined.

Please note that the two meters at the far right of the control bay are *always* used for PFL and CR monitoring and cannot be assigned to a channel.

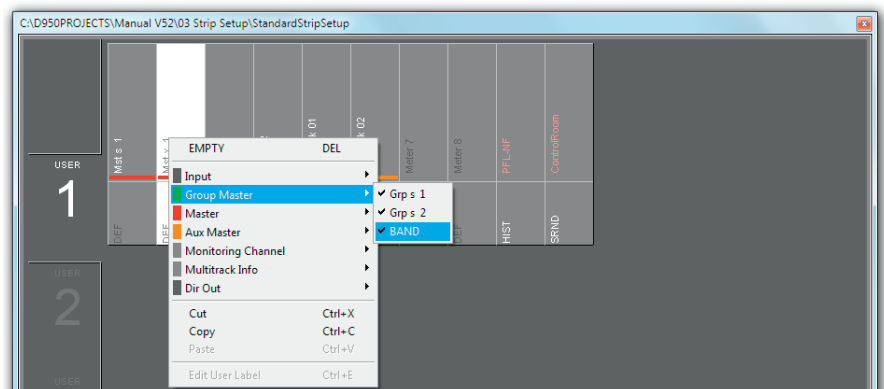

4.4.6.1.7 FaderGlow

The FaderGlow color assignment is performed in the strip setup as well.

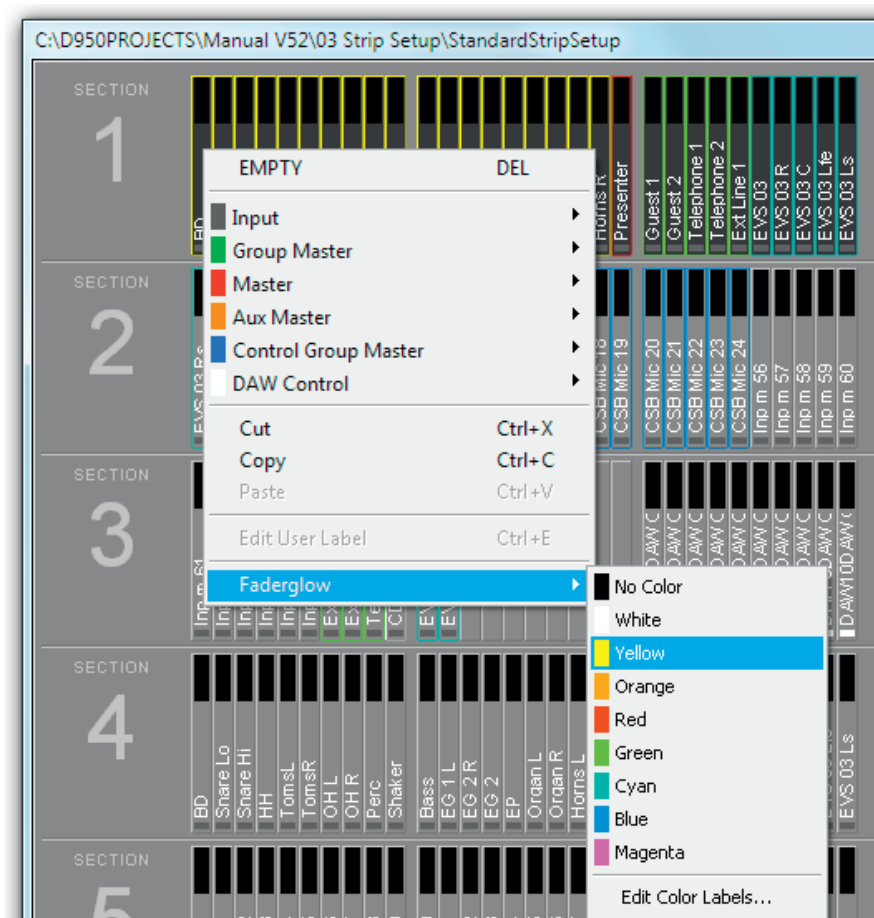

After a right-click on the desired channel, click on the 'Faderglow' item; a list will drop down offering the eight available colors and 'no color', i.e. FaderGlow switched off. In order to give the channels within the same FaderGlow color group a label, click on the 'Edit Color Labels' item. A menu with label entry fields for every FaderGlow color will open up.

The FaderGlow setup is saved as a part of the Strip Setup, allowing different operators who might alternately mix a show having their own, personal color setup.

4.4.7 Clipboard Libraries

On the Vista console it is possible to save and load clipboards to/from the external memory device. Clipboard files can contain one or more audio functions (e.g. EQ only, Dynamics only, or a combination of EQ and Dynamics) from a channel, or even can save complete channel settings. This is then representing a 'clone' of a channel, including bus assignment. By recalling such a channel from the clipboard library it is easily possible to bring the channels of a console into a certain status without even using snapshot functions.

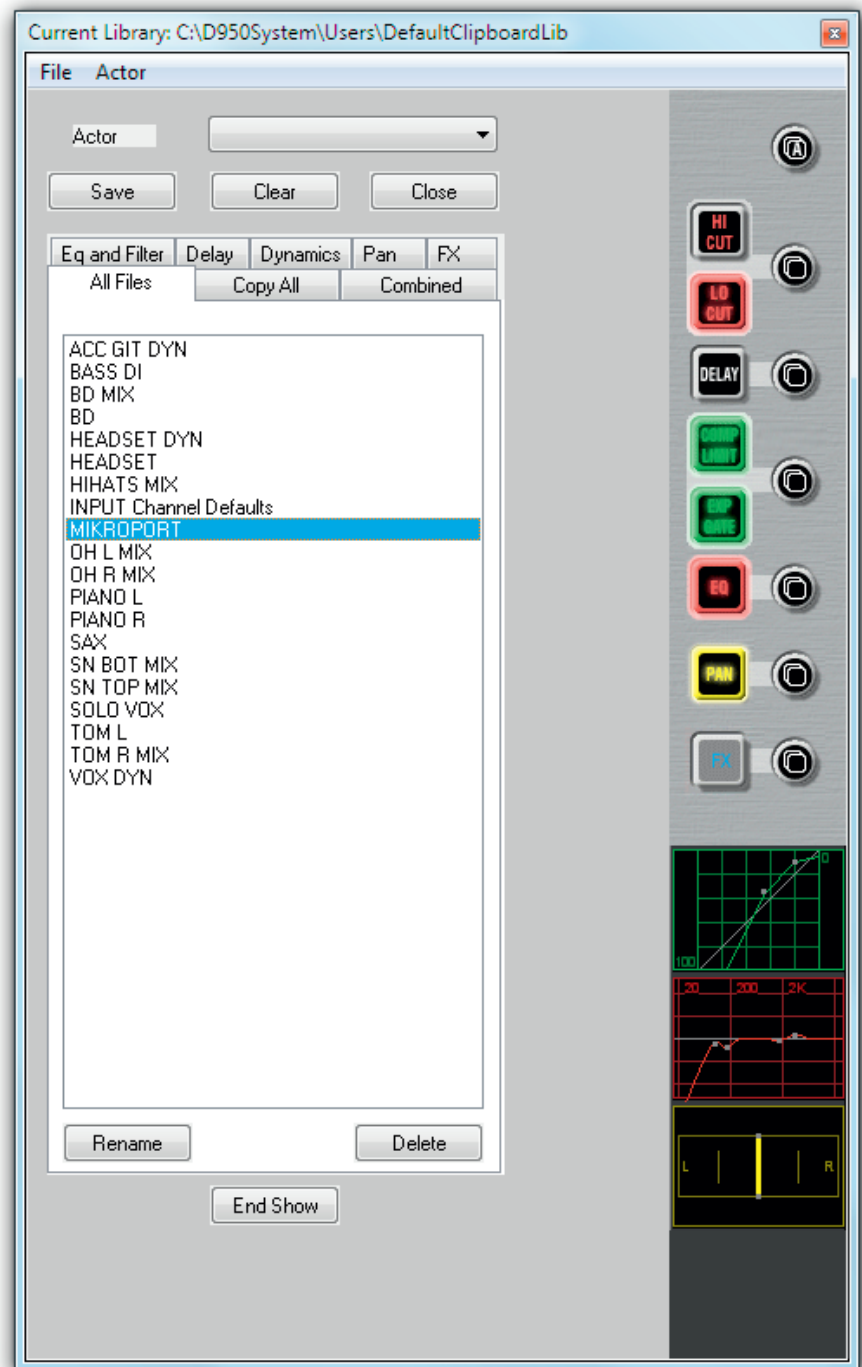

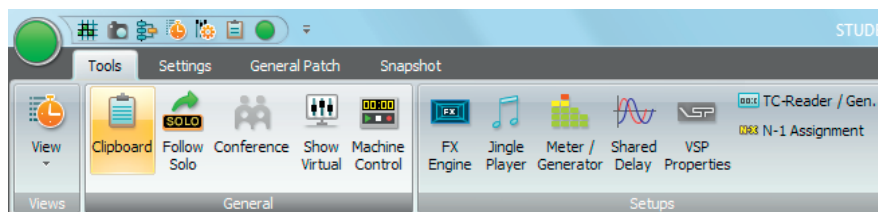

4.4.7.1 Clipboard Library Window

The Clipboard Library window is automatically opened whenever a paste function is pending on the Vista console. In order to open the window manually (e.g., to load the console clipboard with a saved value), select the corresponding icon from the toolbar or press the **Clipboard Library** key on the console. It is also possible to select the window from the View menu.





The window may be closed by clicking on the close box on the top right corner of the window, by clicking on the Close button, or by pressing the **Clipboard Library** key again.

4.4.7.2 Paste into Clipboard Library

- 1 Press the  (Copy/Paste) key on one or more audio functions of any channel strip(s) on the console surface. The Clipboard Library window will be opened automatically whenever a paste operation is pending.
- 2 Click on the half-lit  button in the window. If multiple audio functions are pending to be pasted (e.g. EQ and Dynamics settings), it is possible to click on the half-lit  A (Copy/Paste All) button in the window. The pasted values will be graphically displayed.
- 3 The Save dialog opens, now you can give a name to the clipboard. It will be saved in the currently active Clipboard library.
- 4 Close the Clipboard Library window (see above)

4.4.7.3 Copy from Clipboard Library

- 1 Open the Clipboard Library window (see above).
- 2 If the desired library is not opened already (indicated in the title bar of the window), open the requested library by selecting 'Open Library' from the File menu.
- 3 Select the desired tab. Each of them represents a group of saved settings, which means that all listed files within a tab have the same type of audio function settings. 'All files' will show a list of *all* available clipboard files within this library, containing all the content of the other tabs. Files in the 'Combined' tab contain a combination of audio function settings. (e.g. EQ and Dynamics settings together). Files in the 'Copy All' tab contain complete channel settings.
- 4 Select a clipboard setting from the list by clicking on it. This will activate a preview function on the panel, shown at the right-hand side of the window. In this way it is easy to search for a special setting by looking at its graphical representation. The preview function lets you also identify which audio functions are contained in the selected clipboard file: The graphical representation of their 'On/Off' key will be grayed-out if there is no value present in this file.

- 5 Click on the  (Copy/Paste) button of the desired function in order to activate copying. The button will light, and all possible destination keys on the console surface will be half-lit. Shortcut: A double-click on the clipboard name in the list will activate copying of all contained audio values within that particular file directly.
- 6 Paste the value into one or more channels of the console, using the standard functionality. If the clipboard contained multiple audio settings, such as EQ and Dynamics, they may be pasted together by pressing the  A (Copy/Paste All) key of the destination channel.

4.4.7.4 Rename/Delete a Clipboard Library File



- 1 Open the Clipboard Library window (see above).
- 2 Select the file you want to change or delete by clicking on it. Click on the 'Rename' or 'Delete' button of the Clipboard Library window in order to execute the desired action.
- 3 Close the Clipboard Library window (see above).

4.4.7.5 Clear the Display

By clicking on the 'Clear' button, the previewed settings are cleared, and no graphical indication is shown on the right-hand side of the window.

4.4.7.6 Update a Clipboard File

To combine, for instance, the current dynamics settings of a channel with the EQ settings that are already in the library, and to save them as one new set into the library, proceed as follows:

- 1 Open the Clipboard Library window (see above).
- 2 Select the desired, already saved EQ setting by clicking on it once. The EQ settings will be displayed graphically on the right-hand side of the window.
- 3 Press the  (Copy/Paste) key in the dynamics section of the source channel on the console.
- 4 Click on the half-lit  (Copy/Paste) button in the dynamics section of the window.
- 5 Both EQ and dynamics values will now be displayed on the right-hand side of the window.
- 6 The Save dialog opens. Once saved, the new, combined set will now be displayed within the 'Combined' tab.
- 7 Close the Clipboard Library window (see above).

4.4.7.7 Storage Format

Each clipboard is saved in a file with a .cpy extension. Multiple .cpy files form a library. A .cpy file may contain only one audio function (e.g. EQ settings) or a combination of any audio functions of a channel (e.g. EQ and Dynamics settings).

4.4.7.8 Import a Clipboard File from Another Library

- 1 Select 'Import Clipboard' from the file menu.
- 2 Navigate to the desired library.
- 3 Open the desired .cpy file. It will automatically appear and be saved within the library currently active.

4.4.7.9 Where are Clipboard Libraries Saved?

If you don't want to maintain multiple libraries on your console, you never have to change or define a name; just start directly, using the library functionality. The system will then use a library called `DefaultClipboardLib`.

If there are multiple libraries, you may select 'Open Library' from the file menu of the clipboard window in order to select another library to work with. It is also possible to save the whole library under a different name or to save it to a portable storage device such as a CD-R by selecting 'Save Library' in this file menu. Selecting 'New Library' in the file menu creates a new, empty library.

In technical terms, a library is a subdirectory of the `C:\D950System\Users` directory, it may also be located within any other user subdirectory. Selecting 'New User' creates a new user directory containing an empty Library called `ClipboardLib`.

4.5 Second Level: The Application Menu

The application menu is opened by clicking on the round surveyor icon on the left top corner of the GC screen. It contains most of the Vista system's bookkeeping functions. Management of projects, titles and mixes, access to DSP configurations, backup and import functions, and also the Exit menu are controlled from here.

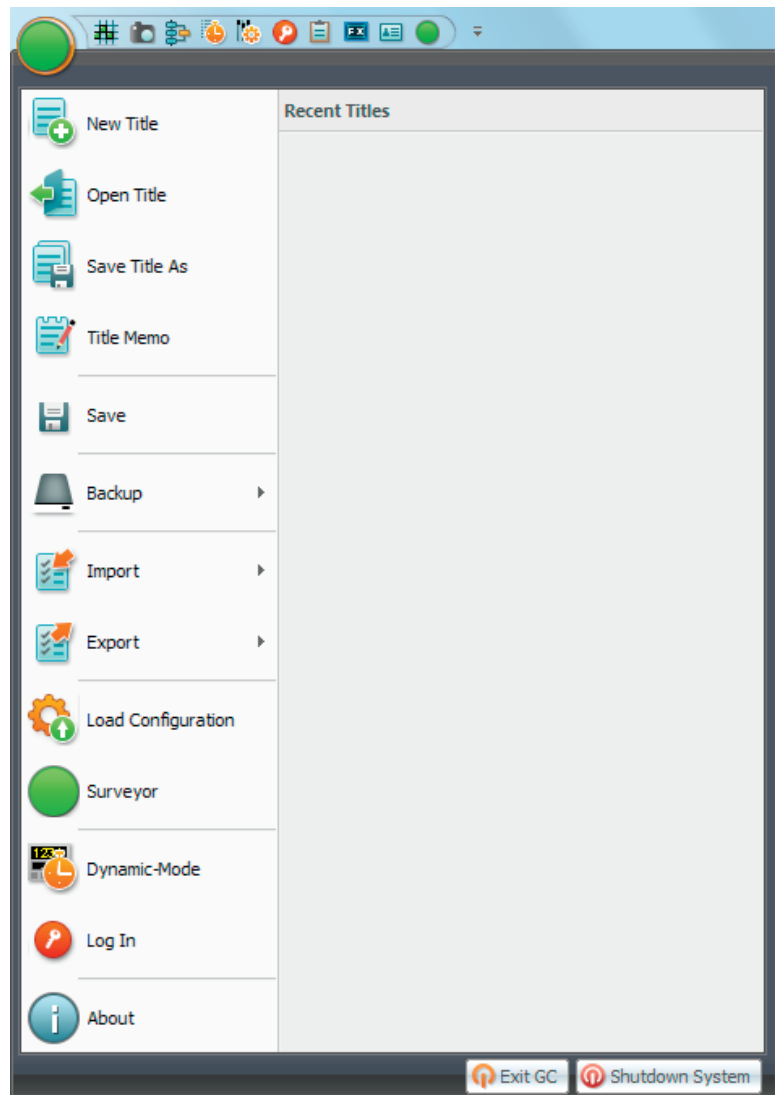

4.5.1 Titles and Projects

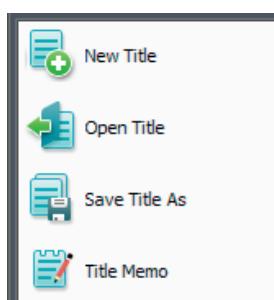

The *Title* is the main container for all the session data. Titles contain all snapshot, mix, cue list, title memo, and other files that relate to each session. Titles also contain pointers that recall the appropriate configuration, monitor file, and so on.

Titles are found in a project folder. Project folders may be created along with a new title. For example, a project folder might be created at the start of an album project when the title for the first song was made. Subsequent titles could be created for each of the other songs and placed in that album's project folder. Projects are located in the D950PROJECTS folder.

New Title This action opens a dialog box that enables the creation and selection of a name for a new project and/or title. You can freely create any number of projects and titles.

Let us assume you wanted to create a new project and title in the Subdirectory D950PROJECTS. Open the application menu, select New Title, and you'll end up with a familiar Windows box:

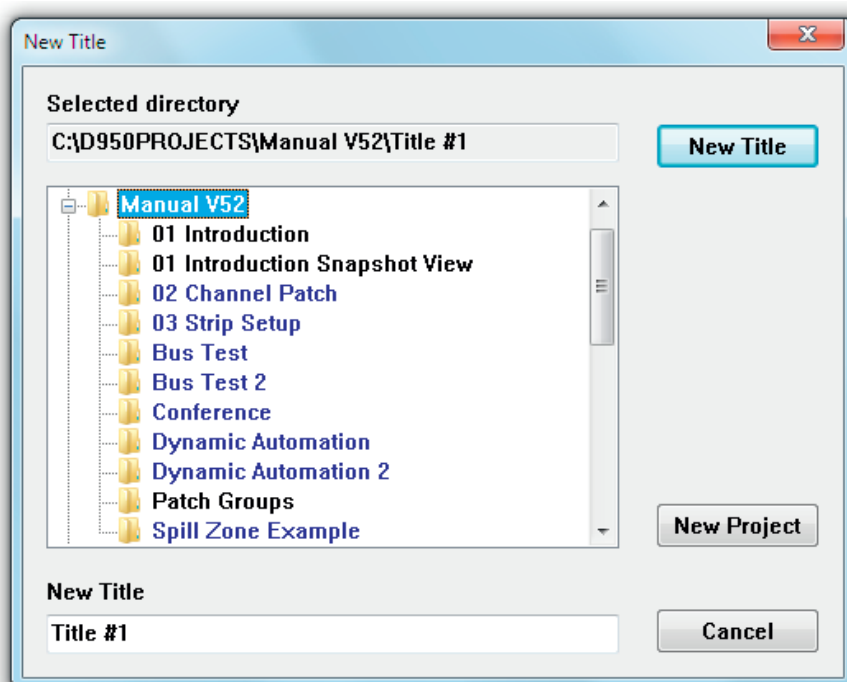

Click on the New Project button and a name entry box will appear. Type in a new project name – for example, *CITY TV1* – and click OK. A new folder with the name you just entered will appear in the list. It will be highlighted in gray, indicating that it has been selected to receive new titles. The New title name entry field (at the bottom of the box) will now automatically display *Title #1* (or the next available number). This will be highlighted in blue, indicating that it is ready to be over-written with a proper name, for example, *BLUES CITY*. Once a new title name has been entered, click the New Title button or press the Enter key. These actions will perform the following:

- Creating a new project subdirectory (C:\D950PROJECTS\CITY TV1);
- Creating a new title subdirectory (BLUES CITY) within the CITY TV1 project folder (C:\D950PROJECTS\CITY TV1\BLUES CITY);
- Creating the necessary title-oriented files that are saved within this title subdirectory;
- Display of the current title name in the title bar.

If you do *not* create a new title, all your subsequent data will be saved in whichever title is currently open. If a title is not currently open you will be prompted to open or create a new title before data can be saved.

Tip You should generally organize your Subdirectories in such a way that C:\D950PROJECTS remains the *parent* directory, because the system automatically searches for that particular directory while opening projects, titles, etc. After several weeks of using the Vista system, your directory structure may

create something like this:

Parent	Your Projects	Your Titles	Your Data
C:\D950Projects	\SuperProductions_1	\FirstSong	\FirstSong.tit \Snap1 \Snap2
		\SecondSong	\SecondSong.tit \Snap11 \Snap12 \Mix1 \Mix2
C:\D950Projects	\SuperProductions_2	\EveningShow	\EveningShow.tit \SnapBaby \SnapBaby_new \Mix
C:\D950Projects	\SuperProductions_3	\MorningShow	\MorningShow.tit \CoffeSnap_1 \CoffeSnap_2 \MyNewMix

...and so on.

Open Title This action opens the list of project folders from the D950PROJECTS directory. This enables the selection and opening of an existing title from a selected folder. Titles can also be deleted from this menu item.

To open an existing title, first double-click on the desired project subdirectory, an action that will move you into its Subdirectory:

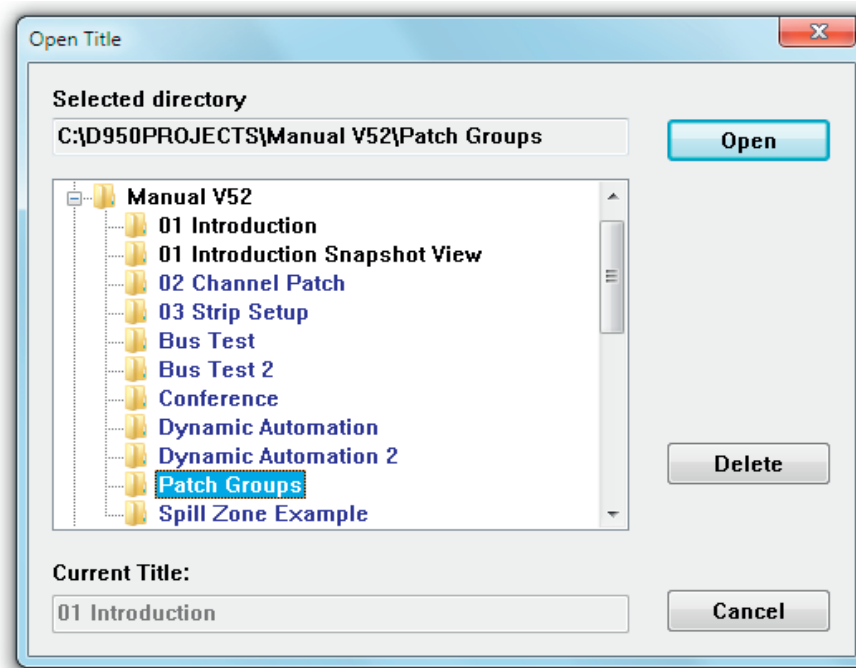

The desired title can now be opened by double-clicking on the title folder or by highlighting it and clicking the Open button. This action will perform the following:

- Make the new title the *current* title, making available all snapshots, mixes, etc;
- Indicate the current title name in the title bar.

A title can be deleted by highlighting a title's name (while in Open Title) and clicking on the Delete button. You will be asked to confirm this action. You cannot directly delete a project folder using this technique. However, if you delete the last title from within a project folder, you will be notified that the empty folder will be automatically deleted.

Note Titles are color-coded according to the status of the DSP configuration that was in use during their creation. Black, blue, and red title names indicate the following:

Black The DSP configuration needed for this title is currently loaded;

Blue The DSP configuration needed for this title is not currently loaded.

Save Title As... Opens a Windows dialog box allowing to select a new name and to save the current title's data under a new name. The process is similar to 'New Title' because it creates a new title under a new name. The difference is that it also copies all the snapshots, mixes, etc., from the current title into the new title. So, it will do the following:

- Create a new title subdirectory with the new name;
- Copy all data from the current title into this subdirectory;
- Make the new title the *current* title;
- Indicates the current title in the title bar.

To save a current title under a new name:

- Select Save Title As... from the File menu;
- Highlight the desired project Folder;
- Type an appropriate title name in the entry box;
- Click on the Save button or press the keyboard Enter key.

Title Memo The Title Memo editor page allows any relevant title information to be kept for later use. There is one Memo per title. Its contents can include Studio name, Producer Name, Engineer Name, Artist Name, plus a free-form Memo pad. The title directory location and modification date/time are displayed at the top of the title memo page.

To open the title memo, open the application menu and select Title Memo.

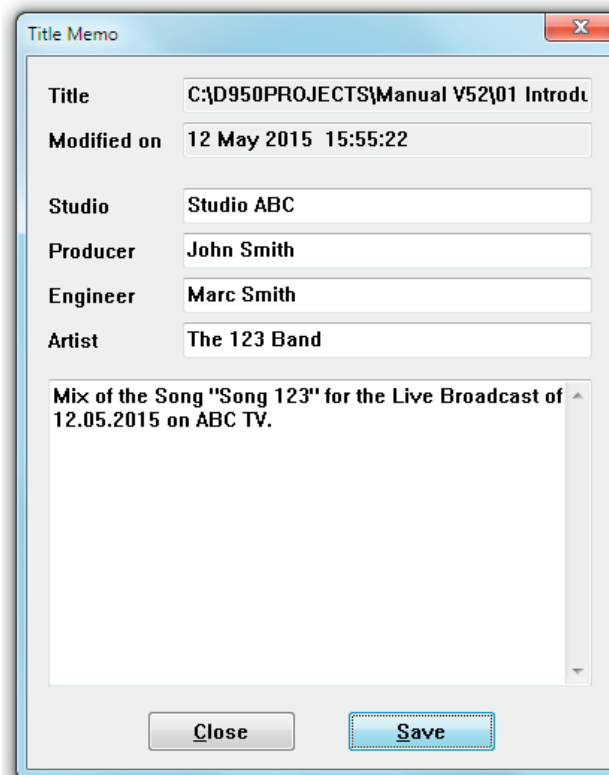

Note: The title memo *has no function key* on the control surface keyboard.

4.5.2 Save

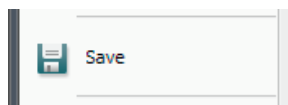

Selection of the Save menu item will save all title oriented information to the currently opened title.

Since this happens automatically when changing to another title or when leaving the application, this button possibly may never be used.

4.5.3 Make/Restore Backup

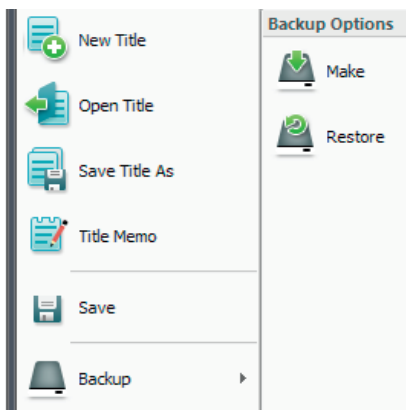

The Vista provides a powerful and easy-to-use data backup utility. This feature enables the creation of a backup subdirectory that contains a copy of all files from the title folder and all pertinent configuration and system files needed to recreate the session on this or another Vista. These backup files can be used for data protection and easy transportation of titles between Vista equipped facilities.

Backup directories can be made on any storage media of sufficient size. They can be used to restore all of the files and information needed to recreate the title at a later date or on a different Vista.

Make Backup

This action opens the Create Backup window, where a destination for the backup directory is selected. backup directories are automatically named by the utility. After the BCK_D950_BACKUP... portion of the title, names include the title name and dates of modification and origination.

To create a backup directory for the current title:

- Select Make Backup from the Application menu;
- Select the destination for the backup directory;
- Click the OK button or press **Enter** on the keyboard

These actions will perform the following:

- Creation of a new backup directory at the desired location;
- Name and date the directory.

Restore Backup

This action opens the Restore Backup window entitled, where a backup directory is selected for reloading.

To restore a backup directory:

- Select Restore Backup from the Application menu;
- Highlight the desired backup directory;
- Click the OK button or press **Enter** on the keyboard;

A pop-up dialog box will appear giving you the option of replacing the existing title, saving the restored title as a new title, or canceling the backup. If you select 'Replace the Existing Title', you will not be able to replace the Session Configuration if it is currently loaded and will be given the option to continue. You will also have the opportunity to replace the monitor file if it also exists. Choosing 'Restoring the Title As' will result in the normal Window's save screen.

Notes

Regardless of the method used to create it, after a backup has been restored, the resulting title must be opened before use.

If you move production data between different consoles, it is advisable not to restore certain files onto the destination console, since it may have different hardware. This is valid in particular for the `monitoring.ini` files. You will be asked whether you want to restore these files as well; in this case answer negative if the two consoles are not identical in terms of monitoring.

4.5.4 Import

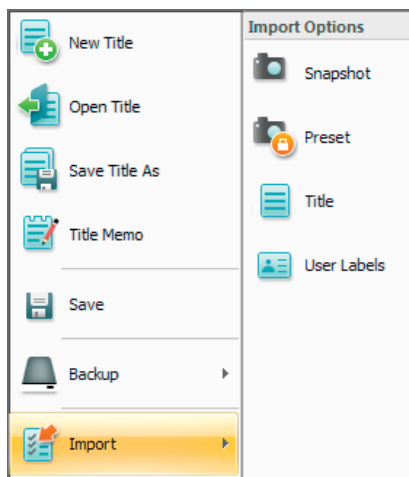

Using the Import utility in the Application menu, snapshots, presets, mixes, titles and user labels can be imported.

- Import** This action is used to select the type of data you wish to import. Once the type of data is selected, an open window appears allowing to select the data source. The following rules apply when using the Import utility:
- Snapshots and mixes can only be imported into an open title
 - Imported presets will be saved with the current DSP configuration
 - Items can be renamed as they are imported
 - A title will need conversion if it is imported for use with a different DSP configuration

Note Importing a snapshot, preset, mix, and/or title will not automatically make it the current one. For example, a snapshot will not be applied to the console upon being imported. It must be recalled, in addition, using the snapshot page.

4.5.5 Export

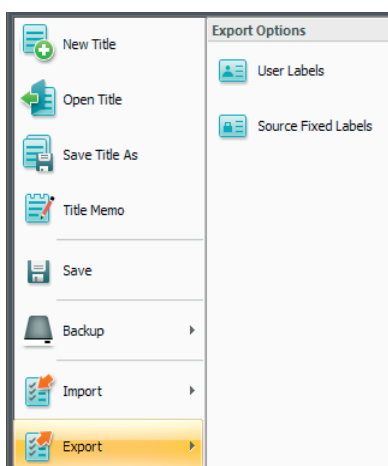

Using the Export utility in the Application menu, user labels as well as the fixed labels of sources can be exported.

To export fixed labels of sources can be useful when creating ProBel configuration files.

4.5.6 Load DSP Configuration

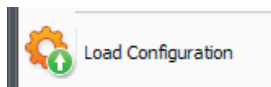

If there is more than one DSP configuration on your Vista system, you may need to access this menu item in order to load a different configuration. Since titles will automatically open the correct DSP configuration (if its not already loaded), using the Load Configuration menu item is only necessary when loading a configuration without opening a Title. Regardless of how a configuration is recalled, this process takes 20 to 30 seconds to complete, and mutes the console during loading.

Note: Keep in mind that all Titles contain pointers that enable the loading of the proper DSP configuration and other appropriate files. If the Title's DSP configuration is different from the one that is currently loaded, you will be asked to either confirm the loading of the correct configuration or to convert the Title for use with the current one. Therefore, during routine operation, it is not necessary to use the Load Configuration menu unless the user has created or modified a DSP configuration during that session. Typically, the Load Configuration menu item should only be used by the facility's System Administrator or by advanced users.

DSP configuration subdirectories reside in the C:\D950SYSTEMDB subdirectory. These subdirectories contain the following files:

- Virtual Mixing Console (VMC) files: These files (with *.vmc extensions) are created by the Session Configuration Tool. They contain all the Configuration data needed for the Session Configuration Tool to create a core file;
- Core files: These files (with *.cor extensions) are created by the Session Configuration Tool. They contain the actual code used by the DSP core (SCoreLive);
- Xml files: The Xml Configuration and VmcMappingInformation - files (with *.xml extensions) are created by the Session Configuration Tool. They contain the actual definition of the processing used by the DSP core (Infinity Core). Also the file MixercloudPaths.txt belongs to this category of files used by the Infinity Core;
- Preset files: These files (if any exist) are created within Titles but are saved with DSP configurations so they can be used with any Title that uses a particular configuration. Preset files have .pre extensions.

Load Configuration: This action opens a dialog box that allows the selection and opening of an existing Session Configuration. A list of available Session Configurations for selection will be displayed.

Tip You should generally organize your DSP configurations in such a way that C:\D950SYSTEMDB remains the parent directory, because the system automatically searches for that directory during opening of a Title or Session Configuration.

To load a configuration, double-click on it, or highlight it and click the Open button. This will do the following:

- Mute the console's audio paths (including the monitoring section);
- Load the appropriate VMC data (core file) into the system, and check their validity;
- Erase the old Session Configuration DSP software from the Flash EPROM in the DSP Core, and load the new DSP software;
- Reload the control surface desk (the Channel Strips will go blank for a few moments);

- Load the appropriate Monitor Configuration file;
- Activate the last used preferences belonging to the newly loaded Session Configuration.

Notes: When a configuration is loaded via the Load Configuration menu, the currently open Title will be closed; no new Title will be opened. Before any data can be saved using the newly loaded configuration, an existing Title must be opened or a new one must be created.

If a DSP configuration is displayed in red this means that this configuration has not been compiled properly by the Session Configuration Tool. Either run the tool again or delete this configuration.

4.5.7 Surveyor

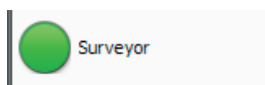

Clicking the Surveyor menu item opens up the Surveyor window which shows the current state of the system. Please see [chapter 4.8](#) for a complete description.

The same Surveyor window is also opened when double-clicking on the Application menu Surveyor icon.

4.5.8 Dynamic-Mode

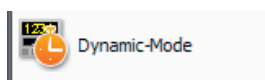

This operation mode is not available for the Vista 1.

4.5.9 Log In (as System Administrator)

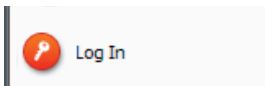

Lets the operator log in as System Administrator by entering a password (if defined at all). All greyed out SysAdmin menu items then become accessible.



Once logged in, this menu item automatically becomes the Log Out function, which allows to leave the System Administrator mode again.

Refer to [chapter 4.7](#) (system administration menu) for more details.

4.5.10 About

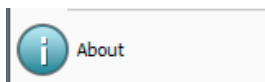

When selected, this menu item displays information pertaining to that specific Vista installation. This includes the software Release Number (version) and the Build Number.

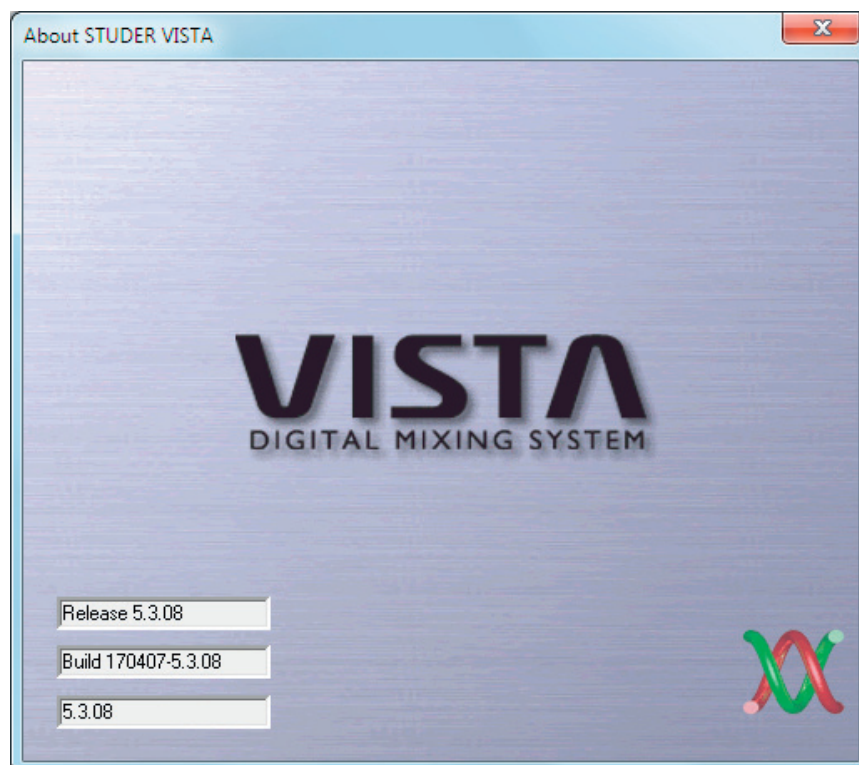

4.5.11 Exit Vista Application





There are three possible ways of quitting the Vista Software application. It is recommended to use the Application menu's *Exit* items : Exit GC or Shutdown System.

Exit GC This action will close the graphical controller (Vista system application) while simultaneously muting all monitoring outputs, and returning to the Windows operating system. All other programs and applications continue to run.

Shutdown System This action will close the graphical controller (Vista system application) while simultaneously muting all monitoring outputs. It also quits all other running applications and the Windows operating system. The desk PC will then be switched off.

In case an UPS (Un-interruptible Power Supply) is installed, and the associated utility is configured to do so, this will also turn off the UPS/PC combination automatically after a pre-set time period.

Using Main Window Control It is also possible to quit the Vista application by clicking on  main window control. There is no confirm box in this case, and the application is terminated immediately.

It could be potentially dangerous for your session if you click on  main window control, because the application will be terminated, and audio will no longer pass. However, the data that was in use will be written to the 'last known session' and 'shutdown' files and will not be lost.

Note: It is possible for an expert to adjust settings in order to make the  close box disappear.

4.6 Third Level: Tools and Settings Ribbon Tabs

4.6.1 The Tools Ribbon Tab

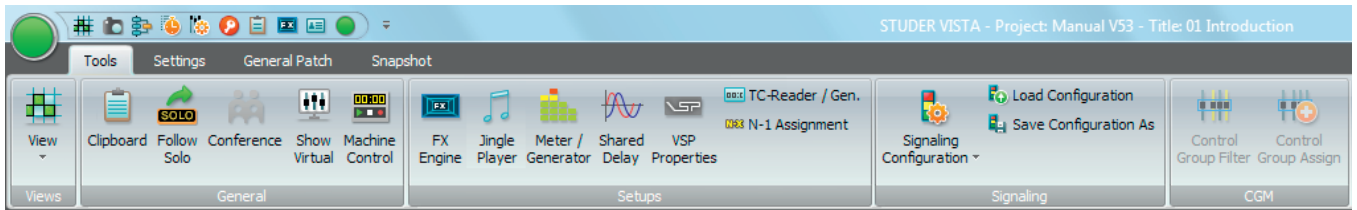

The Tools Ribbon Tab is divided into four categories :

- **General** (Menu items of general usage)
- **Setups** (Menu items for system setup purposes)
- **Signaling** (Menu items concerning signaling configuration)
- **CGM** (Menu items for Control Group Master setup purposes)

4.6.1.1 General

4.6.1.1.1 Clipboard

Clicking on this menu item opens up the clipboard library window (please see [chapter 4.4.7](#) for details).

4.6.1.1.2 Follow Solo

By clicking on this button, the Follow Solo Mode gets activated. This is a global setting which is valid for all titles and remains active until the **Follow Solo** button is clicked again, even if the Vista application had been closed and restarted in between. (Please see [chapter 2.2.5.19](#) for details)

4.6.1.1.3 Offline Conference

Clicking on this menu item allows to activate or deactivate a offline conference.

When configuring the N–X buses, a subset of N–X owner channels may be defined to be members of a conference. Whenever their fader is closed, they will automatically hear all other members (without hearing themselves back), rather than the normal N–X signal. As soon as the fader is opened, they will instantly hear the N–X signal again.

Offline Conference Setup



By pressing the **SETUP CONF** key on the control bay, the console is put into conference setup mode. The **LINK / SEL** keys of all possible conference member channels (all N–X owner channels) are half-lit, and the user may select any number of them to be members of the conference. If the user wishes to adapt this setting frequently, he may even stay in this mode during a live production, since the channels are instantly added or removed from the conference when pressing their **LINK / SEL** key (however, other features such as ganging will not be available while in setup mode).

All the channels currently defined as conference members are marked in the

strip setup window.

The conference icon in the Tools tab has (only two) states:

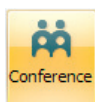

Grayed out : No conference active nor defined

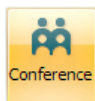

Grayed out : Conference active (if member faders closed)

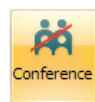

Grayed out, crossed out : Conference defined, but temporarily deactivated (even if member faders closed).

Note: In certain circumstances, also an AUX master can be selected as a conference member (indicated by its half-lit **LINK / SEL** key). This is intended for adding e.g. an on-air signal to the conference. See details below.

Talk to the Conference

When pressing the **TALK** key on a channel which is currently conferencing, the talk function is automatically activated *on all members of the conference* at the same time.

Temporary Conference Deactivation

The conferencing may temporarily be deactivated by clicking on the conference icon  in the toolbar or the **CONF ON** key. In this case the conference definition is retained. As soon as the conference is reactivated globally (by pressing **CONF ON** or clicking on the conference icon in the toolbar again), the previously selected channels may talk to each other again. Temporary activation of the **CONF ON** key is possible as well.

Conference Level

While in conference mode, the N–X send level of the channel conferencing may be adjusted. This level will then be used as a conference send level only. When opening the fader, the level previously set returns. In other words, the system remembers two level settings; one of them is active when conferencing, the other one is activated in normal N–X mode.

Monitoring the Conference Using the MPX Bus

Within the new Configuration Editor software, the MPX bus type has been added. This bus only exists once within a configuration (similar to a PFL bus) and is used to monitor the conference. It is a mono bus. Any channel currently conferencing is automatically assigned to the MPX bus, and the MPX bus output may be monitored using a source selector key. Since the MPX bus output is a normal bus output, it can also be patched to any console output. This allows, for example, feeding this signal to a small loudspeaker for constantly playing back the conference signal.

Adding On-Air Signal to the Conference

It is possible to add an amount of the master signal to the conference, in case the conferencing members should want to constantly hear what's happening on air. This functionality is provided by a special function, whereby an auxiliary master channel is added as a conference member. This AUX bus is fed by the on air signal from the masters.

Procedure: Have one AUX bus configured with an On/Off symbol at the master channels. Have another On/Off symbol between this master channel and all N-X buses (this step is normally performed by the N-X wizard available in the Configuration Editor software.)

Define your conference members by pressing **MPX** and selecting any of the half-lit N-X owner channels, and add the AUX master channel as a further conference member.

Go to the console master channels and open some level to this AUX bus.

Vary the N-1 send level on the corresponding AUX master channel in order to add the on-air signal to the conference. Since this feed is taken pre-fader, this master's fader has no effect.

Typically, one auxiliary bus is reserved for this use. It may be the one with the highest of all bus numbers, in order to avoid confusion with the rest of the buses. By using the new 'N-X setup' wizard within the Configuration Editor software, this functionality can be easily added with all typical settings.

Alternate Signal to N-X Outputs (CUE)

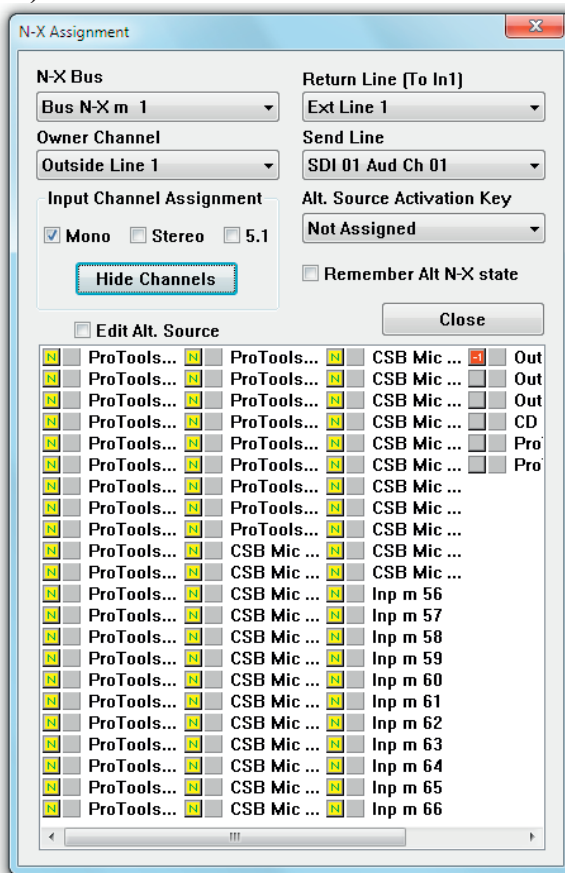

The new N-X bus type allows defining an 'alternate N-X bus assignment'. It is possible to select any console channel (or multiples) to be the alternate

N–X output signal. This signal is activated by the **ALT n-1** key on the channel strip. This can be done only if the owner channel's fader is closed.

If you don't want to use normal console channels to be the alternate signal, feel free to configure simple input channels not used otherwise during the production. Such a channel can be the 'alternate cue signal' source for all N–X buses – or you can define a different alternate source for each N–X bus separately.

Set-up an 'alternate N–X signal' for a specific N–X bus:

- Open the 'Option: N–1 Assignment' menu in the Graphical Controller screen
- Select the N–X bus you want to define the alternate signal for
- Check the **Edit Alt. Source** checkbox
- Select any channel (or multiple) to be the alternate signal source for the selected N–X bus (their pre-fader signal will be used that can be weighted with the 'N–1 send level' to form the alternate signal for this N–X bus).

Note To avoid having to repeat this process too often, such a setup may be saved in a snapshot or preset to be used at any time by all operators.

Option *to bring back ALT N–X status upon closing fader.*

Option active (

Option inactive (original behavior): If the ALT N–X key (i.e. **USR 1** or **USR 2** key defined above) was active and the fader was opened, the return signal would automatically switch to normal N–X. After the fader is closed again, the signal would stay on N–X.

4.6.1.1.4 Show Virtual

When using the Virtual Vista application, this item brings up the virtual desk window and provides access to faders and other desk controls. The GC screen is then moved to the background. (This icon is greyed out when working on a console).

4.6.1.1.5 Machine Control

This menu item brings up the Machine Control window. In case the desk is not equipped with a hardware transport control panel, this software panel allows to do transport control, e.g. for playback devices connected via Sony P2 transport control interface, or also for transport control of a DAW via DAW-control.

4.6.1.2 Setups

4.6.1.2.1 FX Engine

If there are optional Vista FX units connected to the system, this button allows to configure the FX structure to be used within the current title. For details please see [chapter 9](#).

4.6.1.2.2 Meter/Generator

The Meter/Generator Settings page is used for adjusting various settings of the desk channel strip metering and test generator. Generator defaults are automatically saved in the `D950system\shutdown.pfc` file when quitting the system, so that the *last used* defaults are available after the next start of your system.

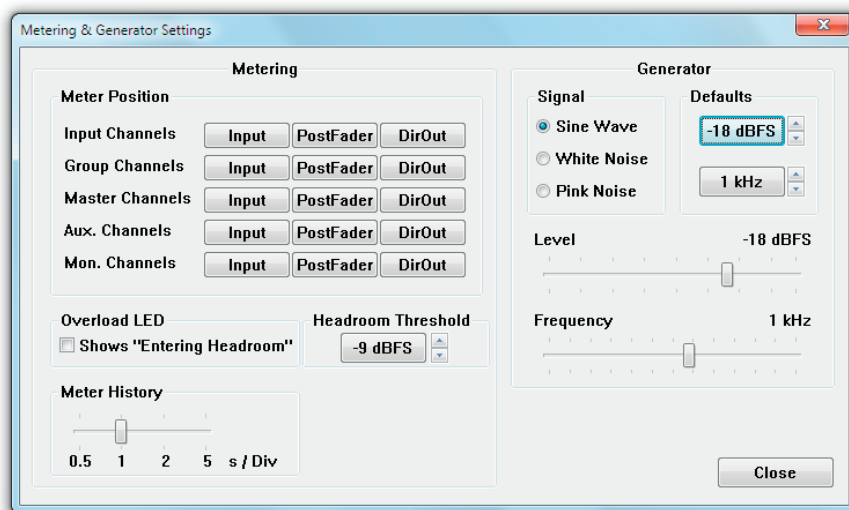

Metering / Meter Position

This action globally sets the metering signal source for all the channels of the same type to the same point within the signal path. It is usual to set the Input Channel and Monitor Channel meter sources to Input and those of the Group, AUX and Master Channels to the Post-Fader position. However, meter positions may be changed on a channel-by-channel basis and saved with snapshots and presets.

Metering / Overload LED

If 'Shows Entering Headroom' is ticked, the Overload LEDs on the channel strips as well as the red overload sign on the TFT screens illuminates when the signal level enters the headroom set with 'Headroom Threshold' instead of an overload condition.

Metering / Headroom Threshold

The desired headroom can be set here; this setting doesn't make any level changes but just sets the threshold level of the bargraph meters. Default setting: $-9 \text{ dB}_{\text{FS}}$, i.e. 9 dB below clipping occurs.

Metering / Meter History

This slider allows setting the speed of the meter history view in four steps from 0.5 s/div (fastest) to 5 s/div (slowest). Default: 1 s/div.

Generator / Level

Sets the test signal generator's level to the desired value. Levels can be set to off and, in 1 dB steps, from -90 to $+10 \text{ dB}_{\text{FS}}$. The Generator Level can be turned off by moving the Level slider all the way to the left.

Generator / Frequency

Sets the test signal generator's frequency (sine wave only) to the desired value. The generator frequency can be set in $1/12^{\text{th}}$ octave steps from 19.95 Hz to

19.95 kHz.

Generator / Signal Selects the waveform of the test signal generator, from Sine Wave, White Noise, and Pink Noise.

Generator / Defaults Sets the test signal Generator's level and frequency defaults by using the arrow buttons to adjust the default values.
To quickly apply a level or frequency default, rather than to adjust it manually, click on the appropriate Defaults button. Default levels can be set in 1 dB steps, from -90 to $+10$ dB_{FS}. The Generator Level cannot be turned off from the Defaults controls. Default frequencies can be set in 1/12th octave steps from 19.95 Hz to 19.95 kHz.

Tip By default, the Test Signal Generator is patched to GEN (the third channel input) of all channels. It also appears as a signal source in the General Patch and can be patched from there to any desired target.

4.6.1.2.3 Shared Delay

The settings of the Stereo and Multi-format Monitoring Delays (for control room, PFL, headphones etc.) are made in the same dialog window where the 'Shared Delay' processes are set.

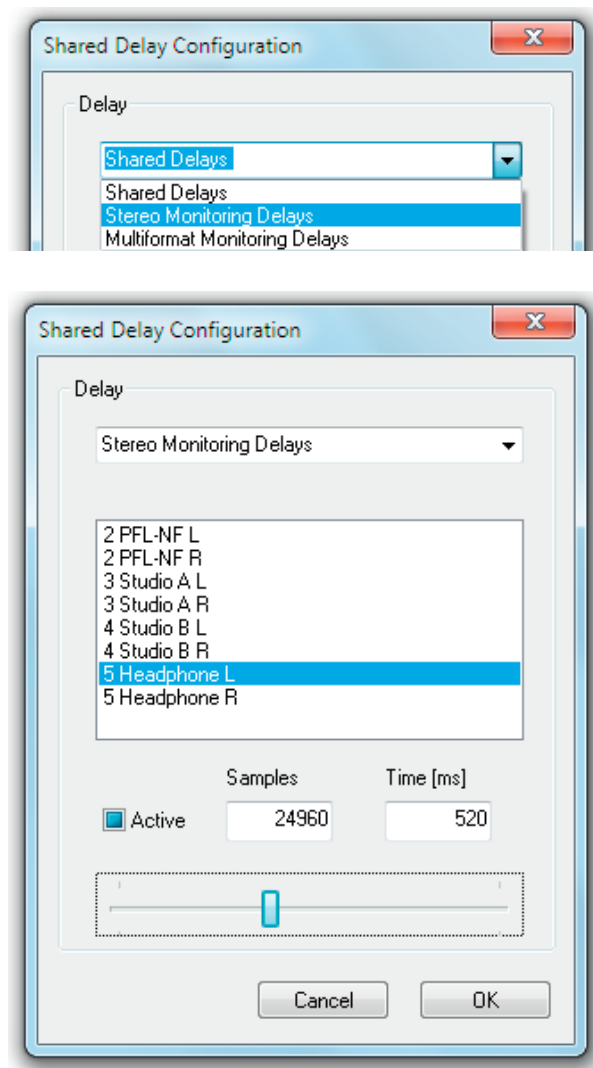

In addition, the shared delays are no more saved in snapshots, but are valid for the whole title. The monitoring delays, however, remain identical throughout all titles (if desired), they are still saved in the **monXxx.ini** file.

4.6.1.2.4 VSP Properties

This feature is described in [chapter 3.4.4.6](#).

4.6.1.2.5 TC-Reader/Generator

The TC Reader / Generator page is used for adjusting various settings of the integrated TC reader and generator, such as the time source and frame rate.

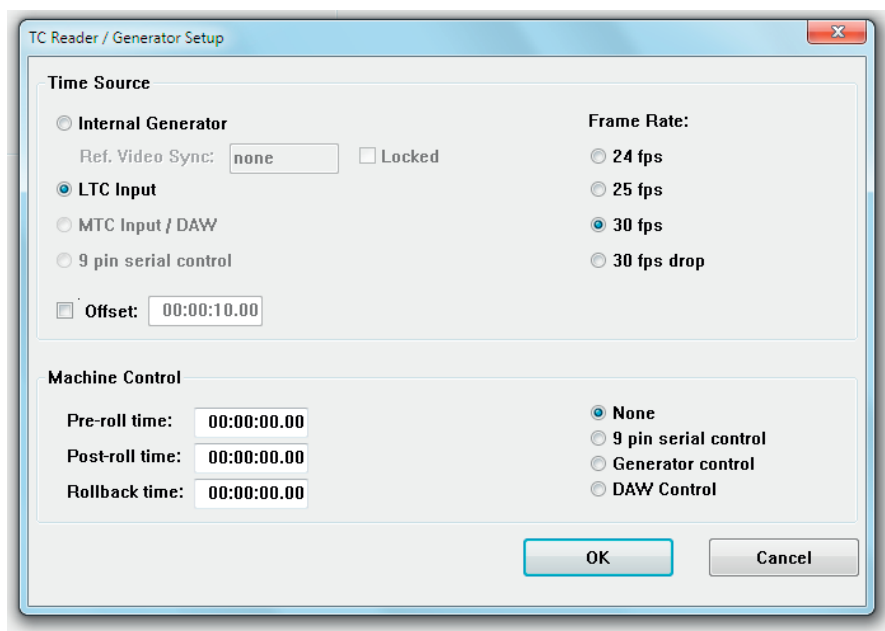

4.6.1.2.6 N-1 Assignment

The N-1/mix-minus Assignment window allows setup and configuration of the N-1/CleanFeed/mix-minus structure.

The principle of N-1 is summing; i.e. all desired channels (N) get summed to a bus except the 'minus one' (-1).

The N-1/mix-minus bus is a special bus that sums the contributions of channels other than the Bus Owner of the Channel, thus performing the N-1 summation. The number of Mono and/or Stereo N-1 busses depends on the currently loaded DSP configuration.

The Bus Owner channel is the channel which:

- Does not contribute to the N-1 bus
- Contains the N-1 bus output level and Talkback controls on the physical channel strip assigned to it
- Has an N-1 indication on the assigned channel strip.

The setup and assignment of the N-1 is done in three steps:

- 1 A Bus Owner (-1 channel) must be assigned to an N-1 bus.

- 2 The N-1 Send Line (Physical Output) and Return Line (Physical Input) must be patched in the General Patch
- 3 The channels which are to be sent to the -1 must be assigned to the bus.

The N-1 Assignment window allows fast setup of this process.

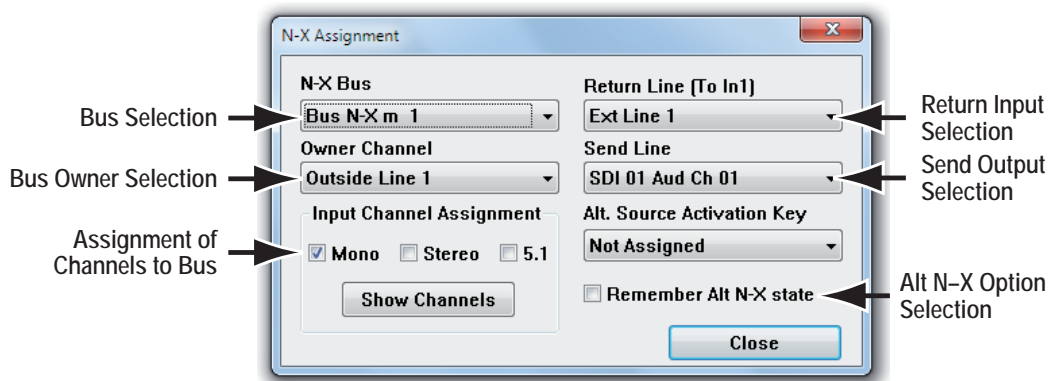

Setup is as follows:

- 1 First choose the N-1 bus to be used with the drop-down menu, and the Bus Owner Channel which will be the -1 channel.
- 2 Use the drop-down menus to select the Return Line (Physical Input) and Send Line (Physical Output) to which the Outside Source (-1) is connected to the console. This is essentially making cross-points in the General Patch without having to go to the General Patch page. Selections made using these drop-down menus will change any previous patching of the Outside Source. *Please note that the label type shown is taken from the General Patch.*
- 3 The three Channel Assignment check boxes allow fast allocation of all Input Channels to the chosen N-1 bus. If only Mono inputs are chosen, then *all* Mono input channels in the system (*except the Bus Owner channel*) are routed to the chosen bus. If specific channels need to be routed instead of *all* Mono, Stereo or 5.1 input channels, the Show Channels button should be clicked. This will extend the window as shown below, to allow individual assignment of the channels to the chosen N-1 bus within the currently loaded DSP configuration.

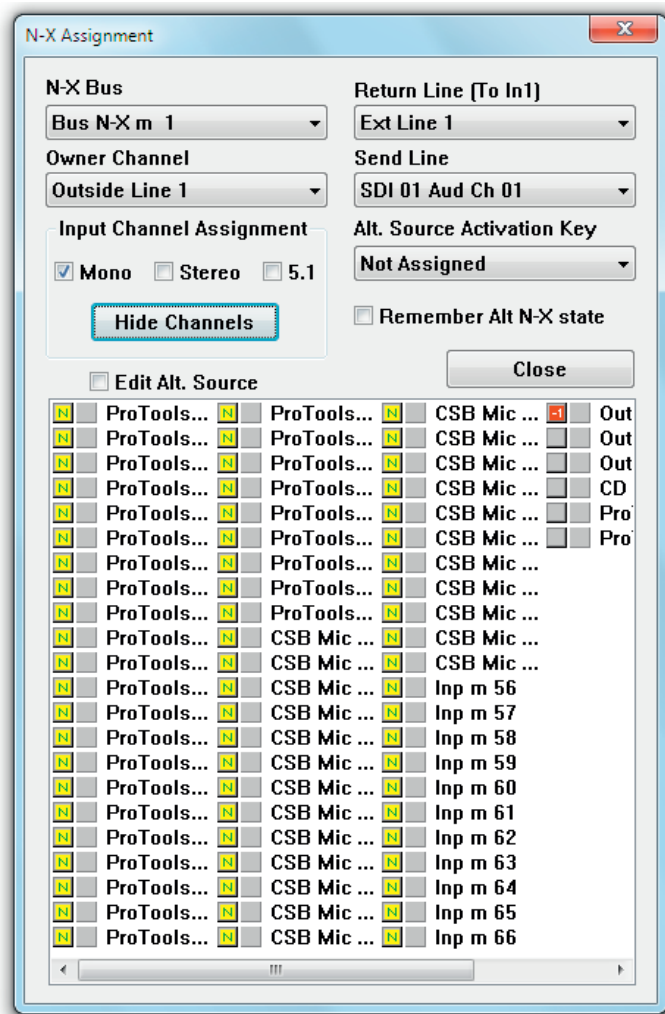

The chosen Bus Owner channel is shown in the list as (in our example, Outside Line 1), any assigned channels to the bus are shown in the list as (e.g. Inp m 56).

Clicking on individual channel boxes will either select or deselect a channel; this makes the N-1 bus in fact being an N-x bus. It is also possible to mark a number of channels to be assigned by left-clicking and dragging across a number of channels for speed.

It is also possible to assign channels to a configured N-1 bus by using the bus assign window on the control surface.

The talkback and N-1 bus level control will be displayed in the assigned channel strip for the N-1 Bus Owner Channel.

Tip The N-1 settings are saved within snapshots.

Option *to bring back ALT N-X status upon closing fader*

Option active (): The signal will switch back to ALT N-X upon *closing* the fader again, in case it was active before opening. This allows e.g. feeding an off-air signal to the outside lines while they are not on air (e.g. output signal from on-air console including commercials).

Result: When the fader is opened, the outside lines get the normal N-X signal; when closed they are switched to the off-air signal.

4.6.1.3 Signaling

The Signaling Setup menu allows on-line assignment of available Signaling relays to functions, such as Red Light activation or Fader Start of remote systems. It also allows Save and Load of such assignment configurations for later use.

Output Signaling is always related to the Patch Sources. The Vista console is fully assignable, meaning that:

- A channel can be assigned to *any* channel strip;
- An audio Source (for example, a CD Player) can be patched into *any* channel and be accessed via *any* fader;
- A snapshot can change the *entire* Patch settings.

For these reasons, it is impossible to assign an output Signaling device, such as a Fader Start relay, to a *specific* fader. Instead, it has to be assigned to the Patch source which, in turn, is assigned to a fader via the Patch. In this way, the system logic is able to activate, for example, the correct relay when a fader is opened. All output Signaling always follows the Sources, and the Signaling Assignment itself also is Source-oriented.

The Vista system automatically knows how many Signaling relays are available by accessing that information from the configuration and *.ini files. The available Sources are read from the Session Configuration. The Signaling Configuration is all about assigning the right relay to the right source, as we will see next.

Editing the Relay Labels

First, the system administrator needs to determine how the relays will be connected to peripheral equipment (machine transport controls, lamps, etc.). Then, the fixed relay labels can be edited to reflect their functions. For this action, select the Edit User Labels button from the Signaling Out or Red Light menu items:

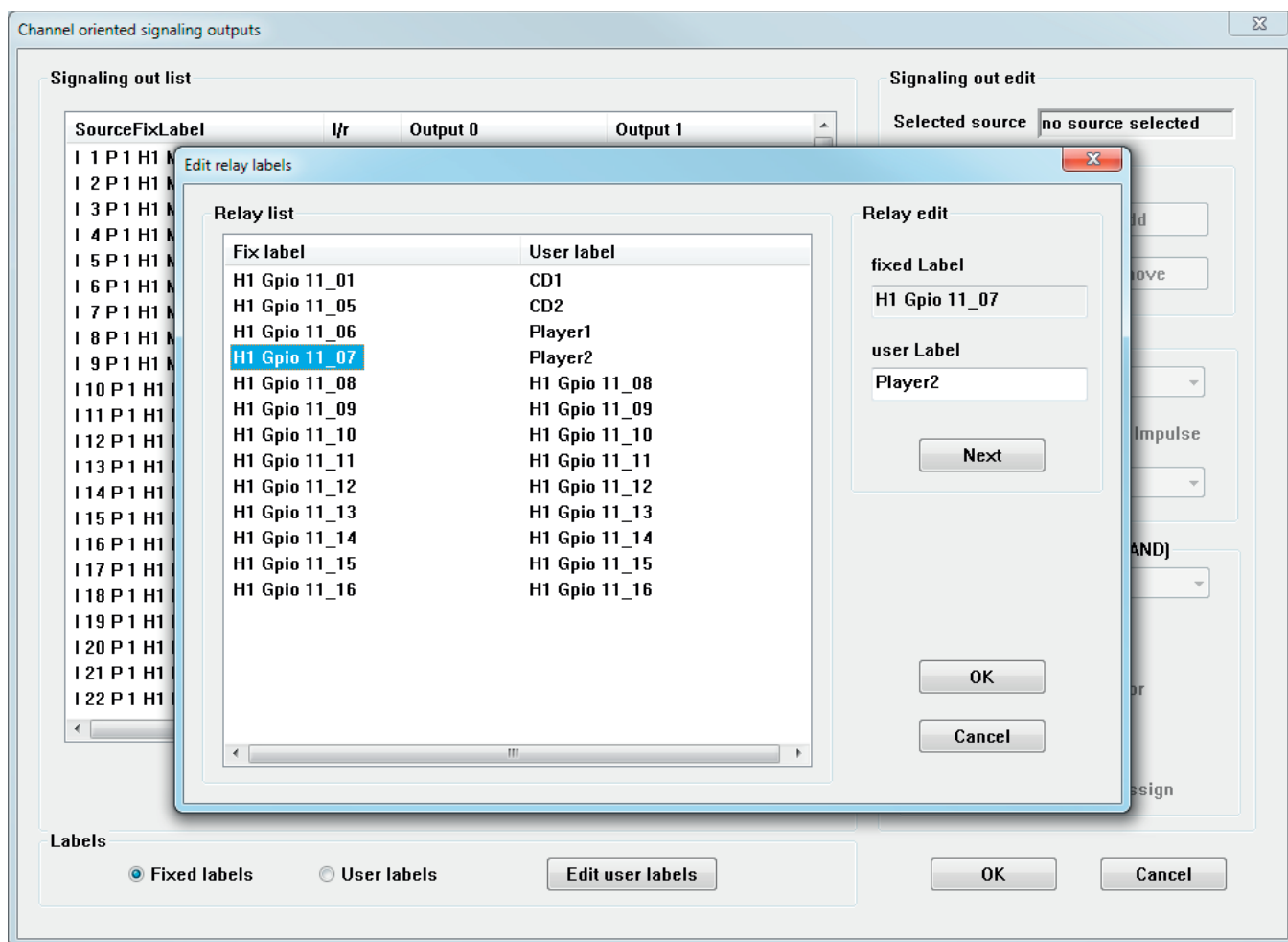

This action will open the Edit relay labels page and first allow selection of the desired relay, and then to enter a user label for each relay. Be sure to click ok when finished; otherwise all changes will be lost.

The fixed relay labels have been automatically generated by the Vista system. They have the format **SIGOUT0_REL01**, where **SIGOUT0**, **SIGOUT1**, etc. define the relay card number, and **REL01**, **REL02**, etc. define the relay number on a particular card.

There are 16 relays per card. Some of the physically present relays may be assigned to internal system functions and may therefore not be available for the Signaling Configuration.

Source labels can be edited in the Patch pages; refer to [chapters 4.4.2](#) and [4.4.3](#).

Signal Out Configuration

Signaling Outputs are generally relay contacts installed in the monitoring frame. They may be used for various purposes, such as:

- Fader Start
- Microphone ON actions (loudspeaker muting, etc)
- Parallel Record/Ready mode of DAW tracks.

Up to four different Trigger relays may be configured for each source. They may feature different Trigger Setups (see later). For each relay, Latching or Impulse

operation modes can be selected.

Multiple sources can be configured to one single relay, forming a logical OR combination.

There are four steps in the Signaling Configuration:

1. To configure the Signaling, first select a source in the Signaling Out List,
2. Within the Signaling Out Edit window, select the desired output 0 to 3. In most cases the correct Output (the next one that is unassigned) will be selected automatically. Now you can add or remove a relay to/from this source.

The screenshot shows the 'Channel oriented signaling outputs' dialog box. It is divided into two main sections: 'Signaling out list' and 'Signaling out edit'.

Signaling out list: A table with columns: SourceUserLabel, l/r, Output 0, Output 1, Output 2, Output 3. The table lists various sources like 'FX1 B Out2' through 'I 94 P 1 Ch94'. The row for 'I 77 P 1 Ch77' is highlighted, and its outputs are 'CD1', 'H1 Gpi...', and 'H1 Gpi...'. A dashed box highlights these three output cells.

Signaling out edit: This panel is for configuring the selected source 'I 77 P 1 Ch77 mono'. It includes:

- Selected source:** 'I 77 P 1 Ch77 mono' (indicated by an arrow labeled 'Selected Source').
- Outputs:** Radio buttons for Output 0, Output 1, Output 2 (selected), and Output 3. 'Add' and 'Remove' buttons are next to them (indicated by an arrow labeled 'Add or Remove a Relay').
- Relay:** A dropdown menu showing 'H1 Gpio 11_09' (indicated by an arrow labeled 'Select a Relay').
- Mode:** Radio buttons for 'Latching' (selected) and 'Impulse'. An 'Impulse time' dropdown is set to '100 ms' (indicated by an arrow labeled 'Select Operating Mode').
- Signaling triggers (logical AND):** A dropdown menu showing 'Faderstart' (indicated by an arrow labeled 'Select Fader Start or User-Defined'). Below it are checkboxes for 'User key 1', 'User key 2', 'Input selector' (checked), 'Channel on' (checked), 'Fader' (checked), and 'Multitrack Assign'.

At the bottom of the dialog, there are 'OK' and 'Cancel' buttons. Below the dialog, four annotations with arrows point to specific UI elements:

- 'Click to Remove all Assigned Relays' points to the 'Remove all outputs' button.
- 'Up to 4 Relays can be Selected per Source' points to the 'Output 0-3' columns in the list.
- 'Select which of 4 Outputs' points to the 'Output 2' radio button.
- 'Set User-Defined Triggers' points to the 'Signaling triggers' section.

3. Now you need to select the desired relay (use the arrow button to open a list of relays), and to determine its mode of operation to either latching (contact closed when trigger conditions are fulfilled) or impulse (contact closed for a short time when trigger conditions are fulfilled, and then opened again). Impulse mode closure time can be set to 100 or 200 ms.

This is a close-up of the 'Relay' dropdown menu. The 'Name' field is set to 'CD1'. The dropdown list is open, showing the following items:

- CD1
- CD2
- Player1
- Player2 (highlighted in blue)
- Mic Sign1
- Mic Sign2
- Mic Sign3
- H1 Gpio 11_11
- H1 Gpio 11_12
- H1 Gpio 11_13

4. The Triggers have to be set according to the application of the selected relay. All Triggers always work in a logical AND fashion:

- The desired Source must be patched to the appropriate Channel (implicitly understood and done in the Patch), and

There is the possibility to check up to five other Triggers to finally trigger the relay:

- User key 1, *and*
- User key 2, *and*
- Input Selector, *and*
- Channel On (MUTE), *and*
- Fader open.

Any combination of the five possibilities above can be used. It is also possible to select from a default list of pre-configured Trigger combinations:

- Fader start, *or*
- User Defined.

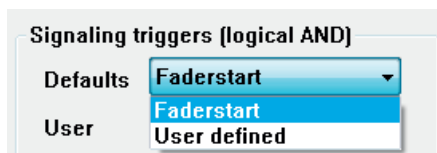

Typical fader start setup for two stereo sources (I77/I78 and I79/I80):

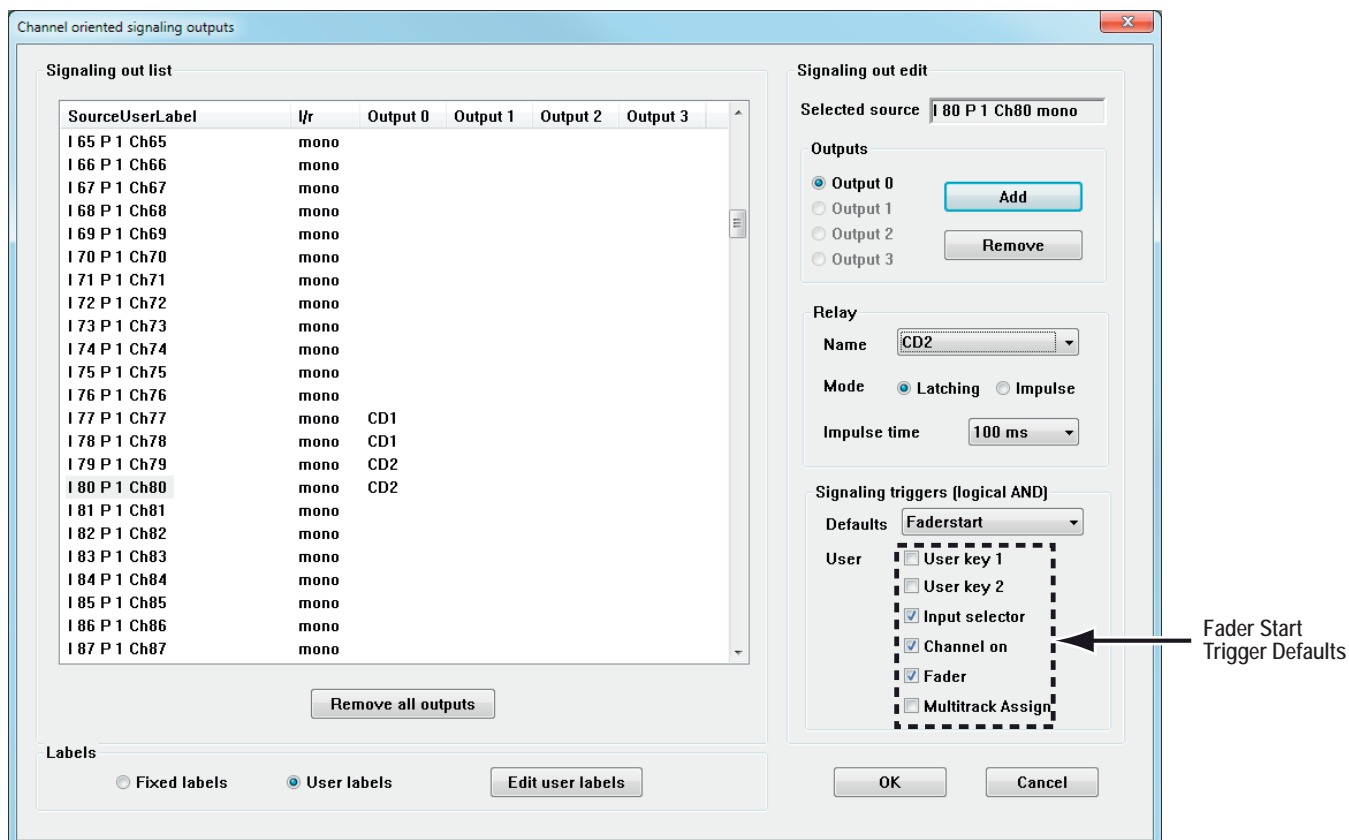

The typical Fader Start Trigger combination is:

- Input selector, *and*
- Channel on (MUTE), *and*
- Fader (open).

You can also remove all assigned relays from the list by clicking on the Remove all outputs button.

- ☞ **Tip** For a typical stereo source, such as a CD player, the same relay should be configured for both the left and the right signal part, as shown in the example above for I77/I78 (relay *cd1*) and I79/I80 (relay *cd2*). This action ensures that the CD player will start even if it is connected to two Mono Input Channels, and only *one* of the faders is opened.

Red Light Configuration

Generally, Red Light Outputs are relays installed within the monitoring frame. Only one relay is normally used for the global Red Light Signaling, but several relays can be configured independently if more than one Studio exists.

The Trigger conditions for a Red Light relay to be activated are fixed to the following:

- A Source configured for Red Light is patched to a Channel, *and*
- The Input Channel Input Selector is set to the above Source, *and*
- The Input Channel Fader is open, *and*
- The Input Channel ON (MUTE) is open, *and*
- The Input Channel is routed to at least one Master Bus, *and*
- The Master Channel Input Selector is set to the above Source, *and*
- The Master Channel Fader is open, *and*
- The Master Channel ON (MUTE) is open.

In other words, the audio signal has a fully open path from the Source to the Master Channel output. If an Input Channel is routed to a group only, then the Group has to be routed to a Master, etc., to fulfill the Trigger conditions. Multiple sources are usually configured to one single relay – they form a logical OR. For instance, all Mic Inputs from the same room would be configured to the same Red Light relay.

There are four steps in the Red Light Configuration:

1. To configure the Red Light, first select a source in the Red Light List;
2. You can then add or remove a relay to/from this source in the Red Light Edit window.

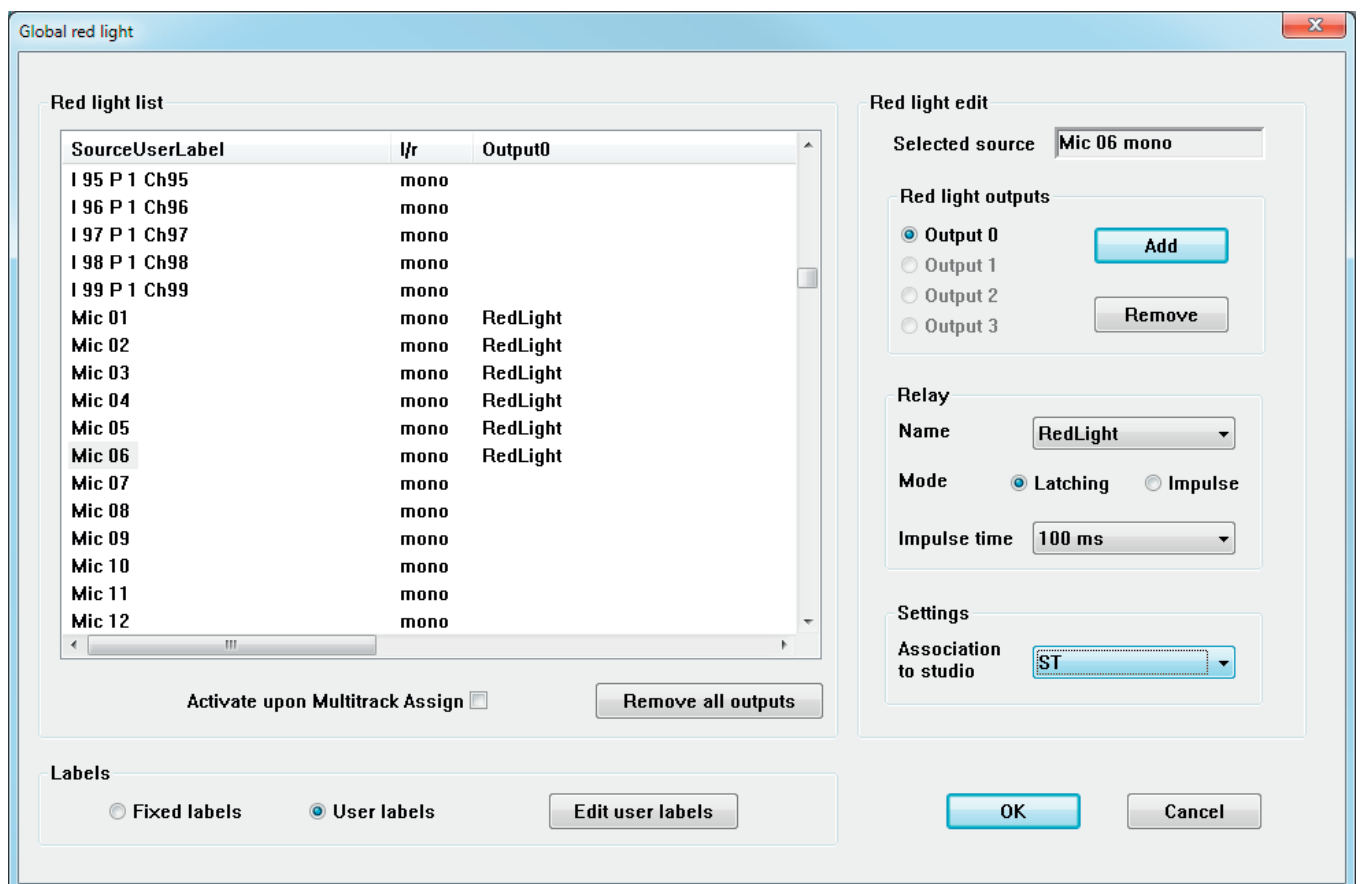

3. Now you have to select the relay itself (use the arrow button to open a list of relays), and to determine its mode of operation to either latching (contact closed when trigger conditions is fulfilled) or impulse (contact closed for a short time when trigger conditions is fulfilled, and then opened again). Impulse mode closure time can be set to 100 or 200 ms. Obviously, the actual relay that is externally wired for Red Light must be selected.
4. In the Settings window, an association to a Studio can be set. Usually, only one Studio is being used. If, however, more than one Studio should be present, each may require its own Red Light relay and its configured Sources. In this case, several relays can be configured independently. To select a Studio, click on the arrow button, and select a studio from the list. If a Studio is associated, the Red Light will also be shown on the Desk's Studio monitor Unit.

You can also remove all assigned relays from the list, by clicking on the Remove all outputs button.

4.6.1.3.1 Load Signaling Configuration

This action opens a window that allows selection from existing Signaling Configurations to load into the Vista. The C:\D950SYSTEMDB directory will usually be displayed first, and a Session Configuration must be selected. The Signaling Configuration files have a *.sig extension. This process will load all saved relay assignments for both the Signaling Out and the Red Light Configurations, and the relay user labels.

4.6.1.3.2 Save Signaling Configuration As

This action opens a window that allows entry of a new name for the Signaling Configurations to be saved. The C:\D950SYSTEMDB directory will usually be displayed first, and a Session Configuration must be selected. The Signaling Configuration files have a *.sig extension. This process will save all relay assignments for both the Signaling Out and the Red Light Configurations, and the relay user labels. Any number of such Configurations can be saved and loaded at a later date.

Note: Each title contains at least one *.sig file that holds the signaling settings of the time when the title was closed or saved manually.

4.6.1.4 CGM

4.6.1.4.1 Control Group Basics

Control Group Master

A Control Group is a group of console channels controlled by a Control Group Master (CGM), similarly to the VCA groups in analog consoles.

The Control Group Master is a dedicated channel of a special type. The sole purpose of the Control Group Master is to control the audio functions of its Members.

Up to 32 Control Group Master channels can be defined by the currently loaded configuration. The number of each Control Group Master is shown on the 7-segment display in the channel strip of each CGM, following the rule:

Control Group No.	Display
1	0
2	1
...	...
10	9
11	A
12	b
13	C
14	d
15	E
16	F
17	0.
18	1.
...	...
26	9.
27	A.
28	b.
29	C.
30	d.
31	E.
32	F.

The Control Group Master channel controls the audio functions of the Members. Master channels can be assigned to desk strips in the same way as any other console channel. The desk strip to which a Control Group Master is assigned will display the following:

- Control Group Master numbers in the seven-segment display next to the fader: 0 through 9, characters A through F (and, for numbers above 16, the same but followed by a decimal point, as shown in the table above);
- The fixed label is set to CGM (Control Group Master), but can be set to display user labels such as DRUM, LVOX, BVOX, RTHM, etc. in the Control Group Filter dialog box in the GC.

Control Group Members

Control Group Members can be selected to and deselected from a Control Group during the console operation. This is done in a special Control Group Edit mode. Any console channel can be selected as a member in a Control Group. The members can be ‘stolen’ from one Control Group to another. When a channel is selected as a member in a Control Group, its channel strip displays the Control Group in the seven-segment display next to the fader in the same manner as described above.

Operating an audio parameter on the Control Group Master influences that parameter on all members (if that parameter has been selected in the Control Group Filter Dialog Box during Control Group Edit mode). It offsets the member value by the move amount of the Master. Operating the parameter on the member influences only that member’s parameter.

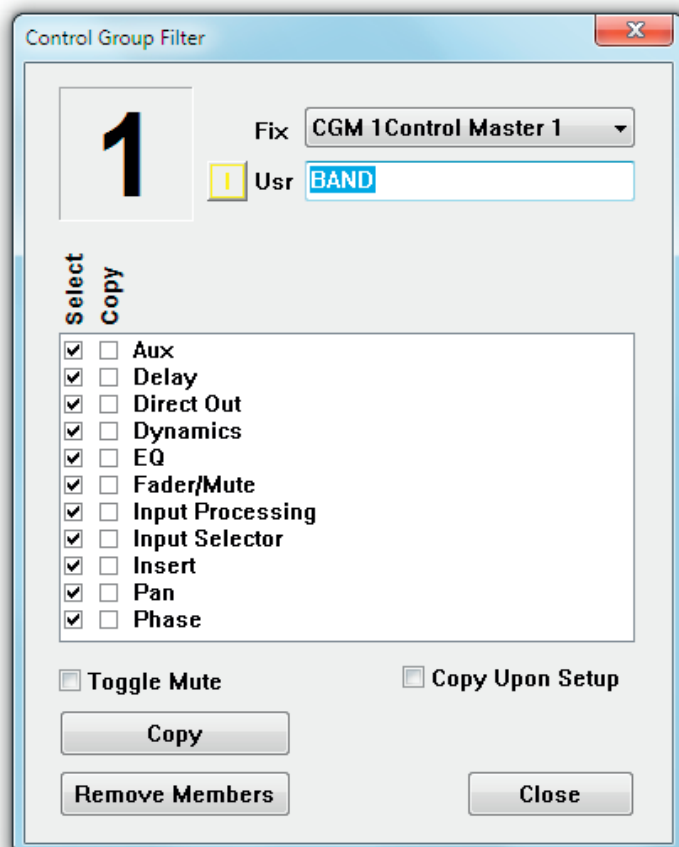

4.6.1.4.2 Control Group Setup

The Control Groups are edited in the Control Group Setup Mode. This mode is activated through the **SETUP: GROUPS** key.

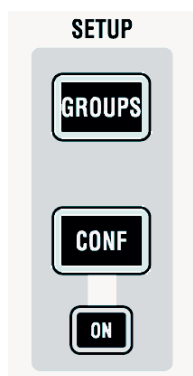

On first press, the **SETUP: GROUPS** key is lit to show that an activity has been started but not yet finished. All **LINK/SEL** keys of Control Group Master channels are half-lit. Pressing one of these enables setting up the corresponding Control Group. The **LINK/SEL** keys of the Control Group members are lit, the ones of non-members are half-lit. The graphical controller automatically activates the Control Group Filter dialog (see above) for the selected Control Group.

When a Control Group is selected for editing, member channels can be added or removed from the Control Group by using their **LINK/SEL** keys. If the **MULTI SEL** key is deactivated, all members are cleared upon pressing any **LINK/SEL** key, similar to creating a gang. During editing, the Control Group is not active, i.e. the setting of the Control Group Master can be changed without influencing the members. This can be used to adjust the offset between the Master and the Members if required.

Editing a control group can be terminated either by pressing the **LINK/SEL** key of the master, or by exiting setup mode by pressing the **SETUP: GROUPS** key in the control bay. If you now want to proceed with editing of another control group, first deselect (using the **LINK/SEL** key) the Control Group Master you have just finished with, and then select the new one that you wish to edit.

4.6.1.4.3 Control Group Filter

When Control Group Editing is activated, the graphical controller automatically activates the Control Group Filter dialog box for the selected Control Group (see screenshot on the previous page).

In the Control Group Filter dialog, the user can define functions to be grouped or not. To group the desired function, the appropriate Select checkbox must be checked. If Select is unchecked, the functions' control can be moved freely without influencing the members. Normally, when the members are grouped, their local values of Fader/Mute are left untouched when the group is formed – they are grouped in a relative way. If absolute grouping is desired, values can be copied from the master to the members:

- By checking the Copy Enable checkbox and clicking on Copy;
- By completing the editing of a group while the Copy Upon Setup checkbox is checked.

There is also a context menu available, called up by right-clicking within the edit dialog:

- If the cursor is placed over the Select items, the menu allows to check or clear all select boxes;

- If the cursor is placed over the Copy column, the menu allows to check and clear all copy parameters;
- and if it is placed over a white space, it does both.

Note: The Control Group Filter dialog box can also be started by clicking on the Control Group Filter item on the Options menu of the graphical controller. Clicking on the Close button does *not* terminate the Desk editing mode.

Absolute/Relative Faders are implicitly controlled in a relative way. This means that all the members will remain in relative positions to each other when the Master Fader (or other control) is moved. The member Faders can be forced to match the Master Fader using the Copy function in the Control Group Filter dialog, see above.

Muting can be controlled in absolute and relative mode. The relative (Toggle) mode for the Mutes can be selected by the user in the Group Filter dialog. If selected, the Mutes can be set to On or Off on the members and will be toggled when the Master Mute is used. If Toggle is not selected, all Mutes on the members will be forced to the same status as the Master Mute the next time the Master Mute is used, regardless of their original status.

Member Behavior When a new member is added to a Control Group, it keeps its values until a change is made in the Control Group Master. At that moment, the change is transferred to all members. When a member is separated from a Control Group it keeps its current setting which includes the Master offset(s) that have been applied along the way. Member values can be changed locally at any time, without affecting the status of the other members or of the Control Group Master.

Over-Range All controls can have an over-range. The over-range condition can occur if the Member Fader has reached its top or bottom position while the Master Fader is still moving. During over-range, the relative levels of the members are kept intact, even if the Fader (and the audio level) can not move anymore. Over-range can be positive or negative. The maximum value of over-range can be twice the normal working range of the Fader (100 dB) in both up and down directions.

The over-range of a Member can be zeroed easily. Simply move the Fader of a Member in over-range by a bit, and the over-range will be zeroed.

Note: This will, however, clear the initial relative level of that particular Member with respect to the other Members.

Snapshots Control Groups are part of the snapshot. Their data comprise three parts:

- Members of a Control Group (which channels are Members in a Control Group);
- Control Group settings (filter and Copy settings);
- Parameter values of the Control Group Masters.

4.6.1.4.4 Control Group Assignment

A Control Group Assignment dialog window can be started from the SysAdmin (system administration) menu in the graphical controller. This window allows to view the members for a selected Control Group and to edit the members by clicking or dragging them graphically on the screen. Selection of the control group to be edited is not synchronized with the Desk selection – so two different control groups can be viewed at a time.

The Control Group Assignment window serves a similar function as the **SETUP: GROUPS** key on the control surface, except assignments are made via software, and the Control Group Filter window does not open.

To assign a channel to a Control Group, select a Control Group Master using the pop-up menu in the field at the top of the window. Channels can be assigned or de-assigned by double-clicking the channel's name. Keep in mind that a channel can belong to only one Control Group at a time. If assigned, a yellow N will appear in the box to the left of the channel name, and the number of the Control Group will be displayed in the channel's fader. Control Group Assignments are saved within snapshots and presets.

4.6.1.4.5 Hierarchical CGMs

It is possible to have control group masters (CGMs) being a member of other CGMs. The indication of the control group number on master channels has therefore slightly changed: The green display next to the fader is constantly showing to which master a channel belongs. If there is no further hierarchical level above a CGM, this area is dark. The number of the CGM itself can be seen in the second line of the label display area.

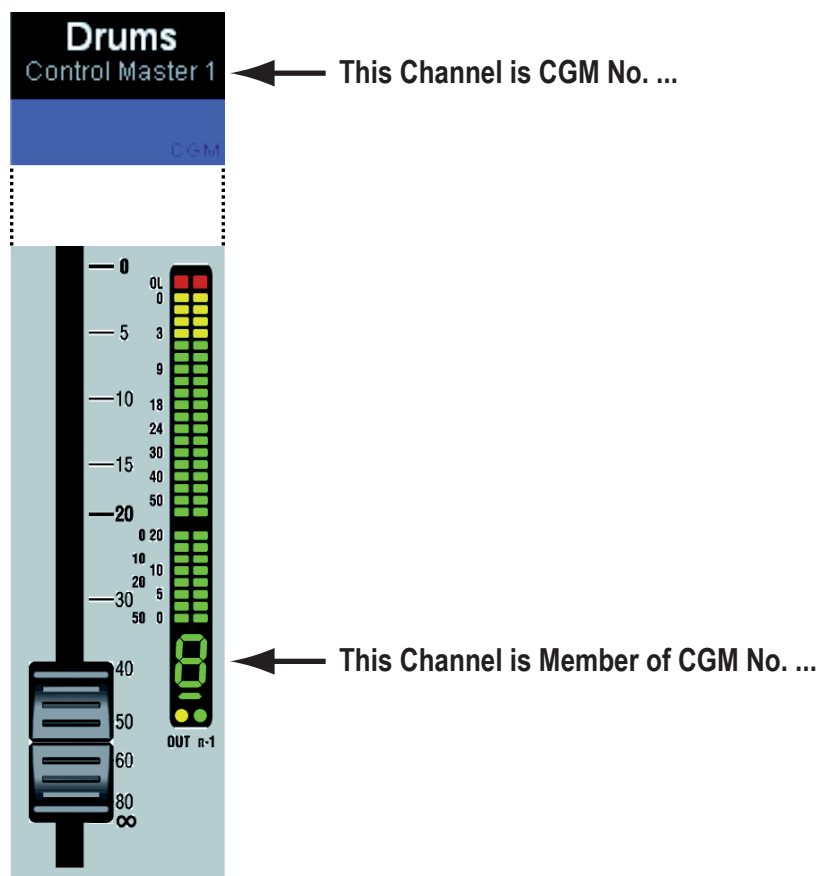

4.6.2 The Settings Ribbon Tab

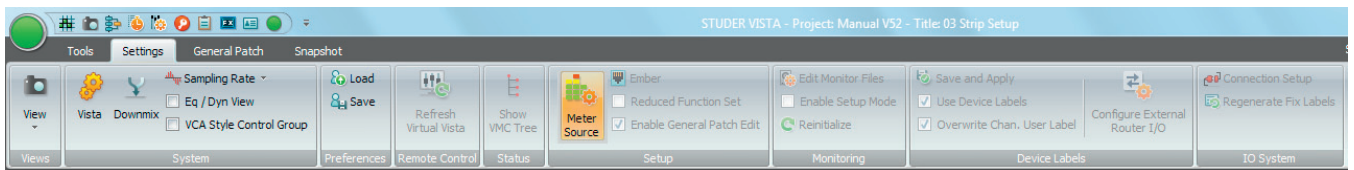

The Settings Ribbon Tab is divided into two categories :

- **System** (System settings)
- **Preferences** (Preferences can be saved and loaded)

.. as well as another six categories which can only be accessed when logged-in as System Administrator :

- **Remote Control**
- **Status**
- **Setup**
- **Monitoring**
- **Device Labels**
- **I/O System**

These six categories are explained in [chapter 4.7](#)

4.6.2.1 System

4.6.2.1.1 Vista Settings

The Vista Settings window allows different adjustments, most of them self-explanatory; there are six tabs for selection of Desk (timeout and delay time settings), Console Lighting, Machine Control, Speaker Calibration, Misc(ellaneous), and View settings.

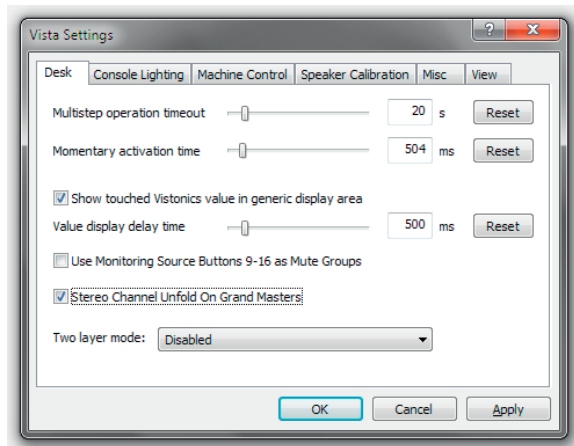

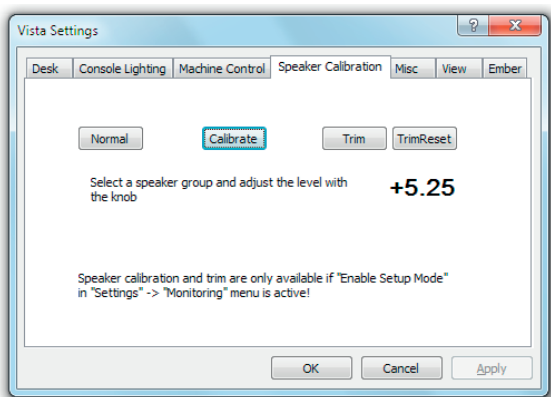
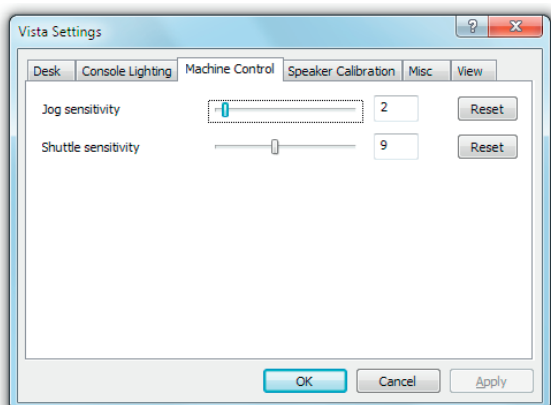
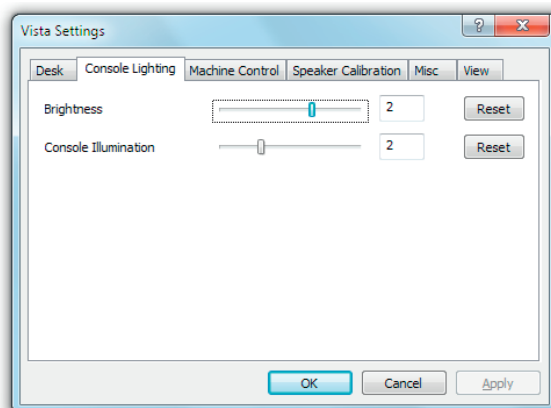

Speaker Calibration

Calibrate Mode

To allow access to the speaker calibration, the Enable Setup function must be enabled. Please refer to [chapter 4.7.8](#).

Calibrate mode allows setting a level offset for a whole monitor group (**MAIN**, **ALT** or **NEARFIELD**) relative to the other two. To activate this mode, click the 'Calibrate' button and select a monitor group on the control surface monitoring section. The offset range is from -20 dB to $+10$ dB. The current calibration offset will be displayed in the display box. The calibration offset can be changed in steps of $\frac{1}{4}$ dB.

Trim Mode

Trim mode allows setting an offset for a single loudspeaker relative to others in a group. The offset range is ± 10 dB. Trim mode is selected by clicking the 'Trim' button. Select the monitor group (**MAIN**, **ALT** or **NEARFIELD**) and **SOLO** the speaker to be offset on the on the control surface monitoring section. The current Trim value of the selected speaker will be displayed in the window. The Trim offset can be changed in steps of $\frac{1}{4}$ dB. To clear all Trim offsets within the selected monitor group, click the 'TrimReset' button.

Misc (-cellaneous Settings)

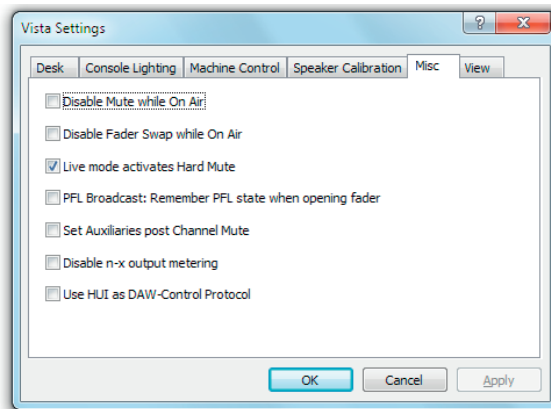

- The MUTE key may be disabled whenever the console is in 'On Air' (live) mode.
- The state of sending the alternate n-x signal instead of the regular one may be restored after opening and closing the fader.
- If the broadcast PFL mode (also referred to as 'PFL cut on channel active' function) is enabled, audio signals are cut from the PFL bus if the channel is ON and the fader is open; the channel will also go back into PFL state when the fader is closed again.
- If 'Set Auxiliaries post Channel Mute' is selected, all auxiliary busses are muted if the channel MUTE key is activated. If this option is not active (default), only the auxiliary busses switched to post-fader are muted upon channel mute.
- The n-x signal output metering may be disabled.
- For controlling a DAW, either the Mackie HUI protocol or the Mackie Control Protocol can be selected. If ticked here, HUI is active.

(Graphic EQ) View

When the 30-band graphic EQ is switched to the faders of a 32-fader console, all faders except the two control bay master faders are used anyway. For 42-fader consoles however, it can be defined here in which fader bay the leftmost EQ band is represented.

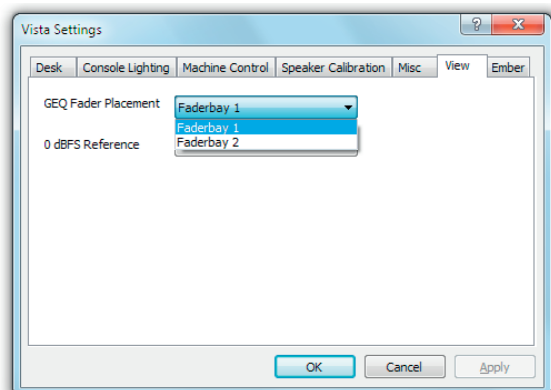

(0dBFS Reference) View

The 0dBFS Reference setting adapts the readout of the Mic Gain dB value to the systems analog reference level.

The analog reference level is given through the calibration of the systems analog D21m Line Input- and Line Output cards. On these D21m cards, the level is calibrated with DIP switches and potentiometers.

The systems analog reference level is calibrated to the customers specification when a system is ordered.

Important : The 0dBFS Reference setting influences only the readout of the Mic Gain dB value. No levels are changed by changing this setting !

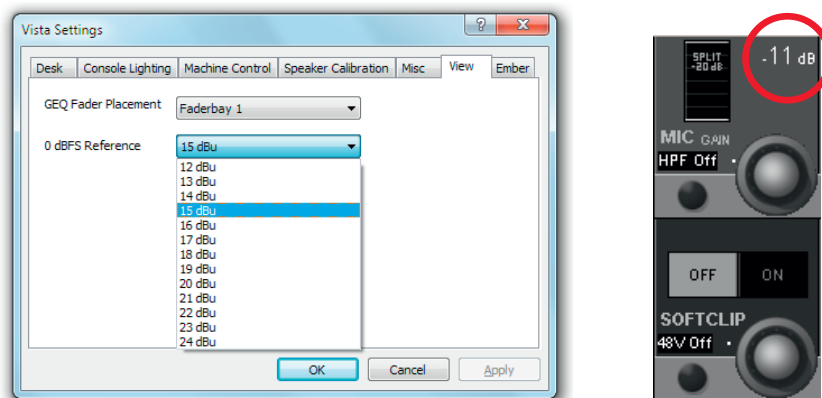

4.6.2.1.2 Downmix Settings

This item allows defining the way in which surround channels are downmixed to stereo outputs as well as their level contributions.

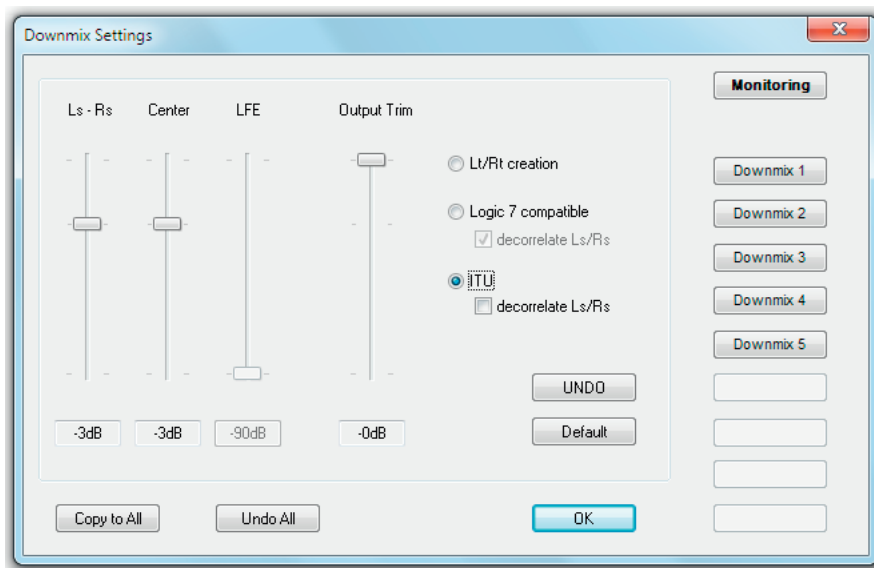

4.6.2.1.3 Sampling Rate

This item allows selecting the audio sampling rate from 44.1, 48 (default), 88.2 and 96 kHz.

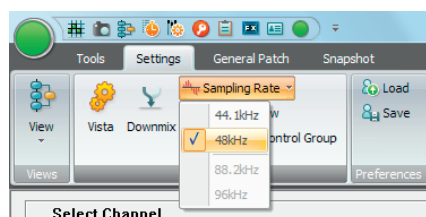

4.6.2.1.4 EQ/Dyn View

The EQ/Dynamics View option can be checked or unchecked. If *checked*, the graphical controller will display an EQ and/or a Dynamics screen.

EQ Screen The EQ screen is displayed for the channel on which any of the rotary encoders is touched or operated while the channel's controls are in the EQ/Filter page. Please note that the EQ screen will appear when any EQ/Filter control is touched. However, for the EQ screen to be displayed, *EQ/Filter must be engaged* in the channel.

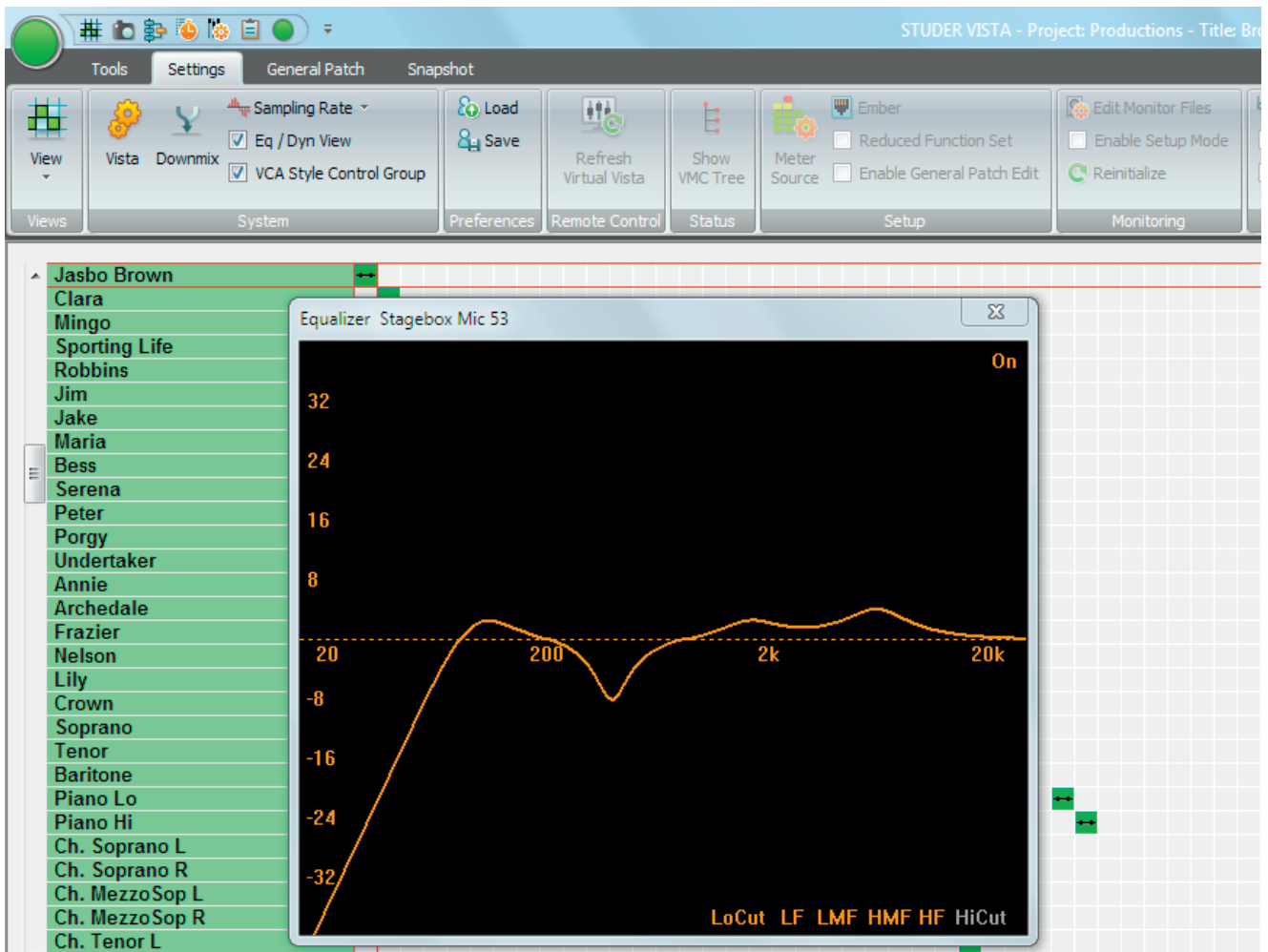

The EQ screen is time-limited and will automatically disappear several seconds after the last touch, or when pressing **Esc**. It is always on top of any other screens/pages.

Dynamics Screen The Dynamics screen will appear when any Dynamics control is touched. However, for the Dynamics screen to be displayed, *at least one of the LIM, COMP, EXP, or GATE functions must be engaged in the channel.*

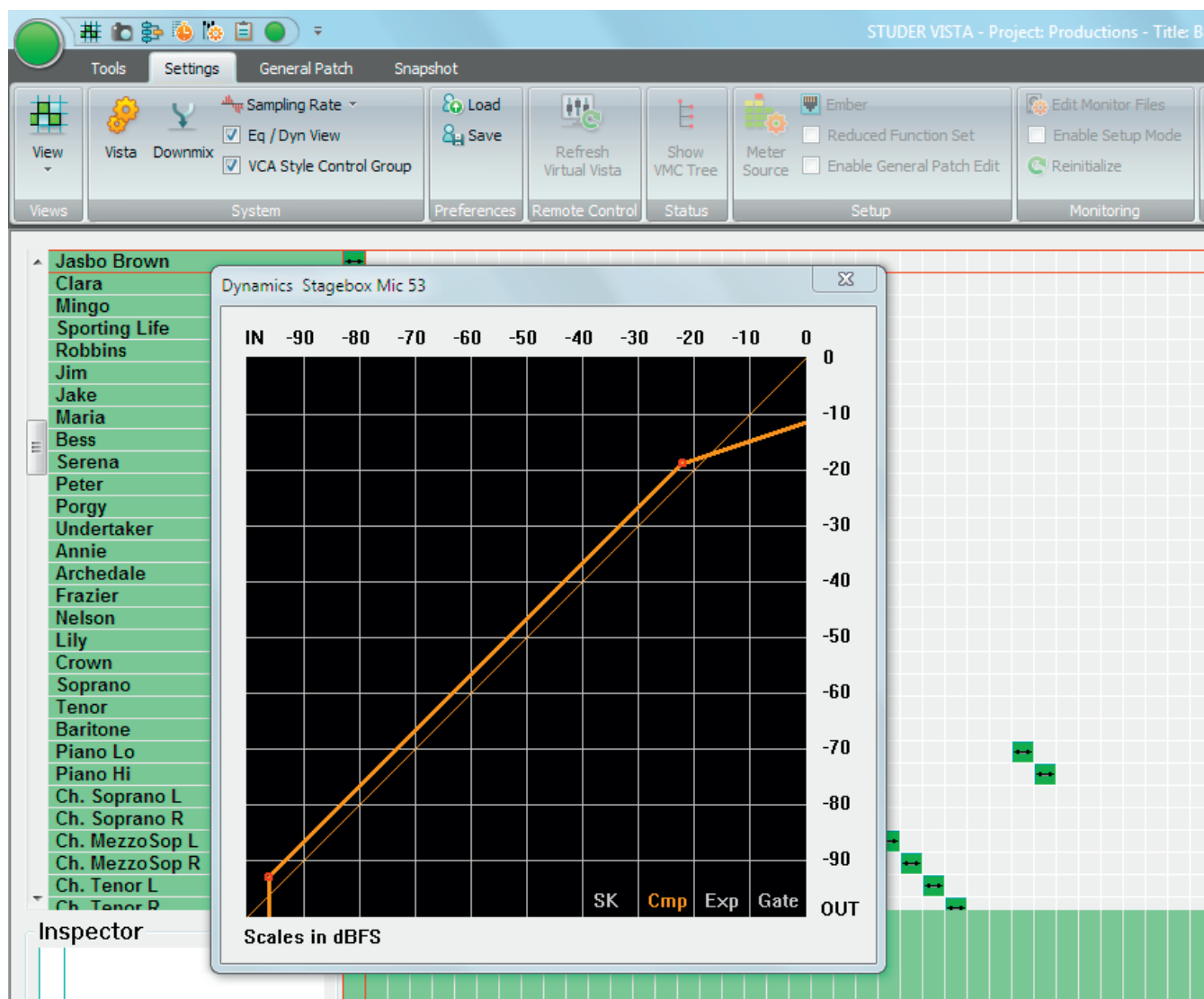

The dynamics screen is time-limited and will automatically disappear several seconds after the last touch, or when pressing **Esc**. It is always on top of any other screens/pages.

4.6.2.1.5 VCA Style Control Groups ('Motors Off')

The 'Control Group Masters' in a classic sense were implemented in such a way that all channel faders belonging to a certain control group would automatically move whenever the master fader was moved. This has the advantage that you always visually see the audio settings currently active in the DSP core. However, there are two drawbacks to this behavior:

When the Control Group Master fader is closed, the user cannot adjust the balance between the member channels, since they are moved down together with the master fader.

When the master fader is closed, it is still possible that there is some audio

passing through some of the member channels, since their fader is not completely closed.

With software release 3.4, there is now an alternative way of how the control group master channels can work, that is very similar to the VCA groups of an analog mixing console. Sometimes, this new behavior is also called ‘motors off’. In this mode, the value set on the control group master channels (as seen on their scale) is added to or subtracted from all member channels, and the resulting (audio) level is set in the DSP core. The faders of the member channels don’t move up/down, and so it is possible to have the master fader closed but still to correct the balance between the member faders. In addition, the user can be sure that whenever the master channel is closed, no audio can be heard from the member channels. Since the fader of a member channel doesn’t represent the real audio value anymore, the digits below the label display are indicating the *real* audio value.

Notes If ‘VCA style’ operation is active, you may see member channels change their fader values as soon as they are added to a control group. This is the case if the master channel is already set to a value different from 0 dB at the moment when a new slave channel is added to the group. This behavior is by intention, in order not to have any audio changing when adding or subtracting member channels from a control group. Example: You have set a microphone channel to –15 dB, and you add it to a ‘VCA’ group the master channel of which is already set to –10 dB. In the moment the microphone channel is added to that group, the user will see the microphone fader jump up to –5 dB. This results in no audio change, as requested.
The **VCA style Control Groups** option can be found Settings Ribbon Tab, category System.

4.6.2.2 Preferences

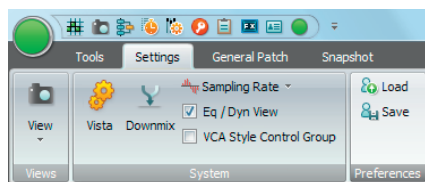

The User menu allows the users to individually save various preferences including page layout, size, and position of various windows.

4.6.2.2.1 Load

This action opens a dialog box that allows selection of a User Preference file for loading. The dialog box will usually display the C:\D950SYSTEMDB directory with all the available Session Configurations.

Enter the desired Session Configuration directory, and select the Preference file to open. Click Open or double-click on the file to load.

4.6.2.2.2 Save

This action opens a dialog box that allows selection of a name for a new Preference file, and to create a new Preference file. You can freely create any number of Preferences. The dialog box will usually display the C:\D950SYSTEMDB directory with all the available Session Configurations. The User Preference files are best saved together with the current Session Configuration in the Session Configuration directory, because they will probably change only when the users change, and not with every production/title.

Enter a name for the new Preference file, or select an existing Preference file to be overwritten, and then click Save to finish.

The User Preference files have the extension *.pfc, which is added automatically; you do not have to type it.

Tip If you should have forgotten to save your preferences, don't worry. The system will save the last-used screen layout at shutdown. When you restart the system, the screen will come up as you left it.

4.7 Fourth Level: SysAdmin functions

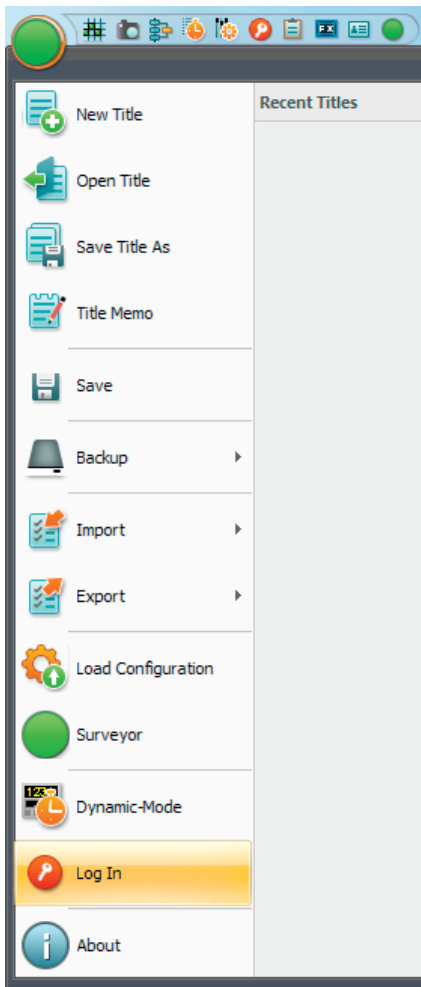

The SysAdmin (system administration) menu items are normally greyed out within the console's standard operating mode, because they are functions that are only useful during building the console and setting it up for operation. The SysAdmin menu items include various test and configuration possibilities that are not required during normal operation.

Nevertheless, some of the SysAdmin functions will be explained here, since they may be useful if the console is radically reconfigured, the monitoring or signaling systems are expanded, or some detailed troubleshooting is required.

Activating SysAdmin Mode from Standard Mode:

Click on the Log In icon in the Application menu. You will be asked to enter the system administration Password. After completing that, all greyed out SysAdmin menu items become accessible.

Once logged in, the Log In menu item automatically becomes the Log Out function, which allows to leave the System Administrator mode again.

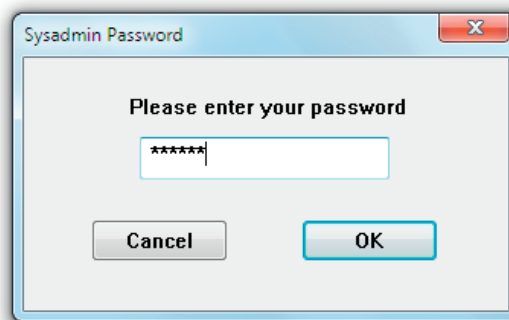

Here is an overview of all SysAdmin menu items, distributed over the four main Ribbon Tabs (Tools, Settings, General Patch and Snapshot) :

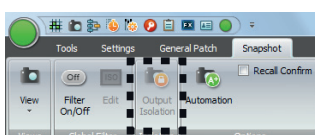
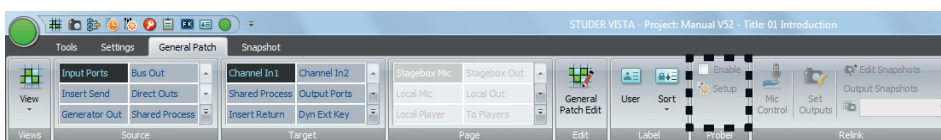
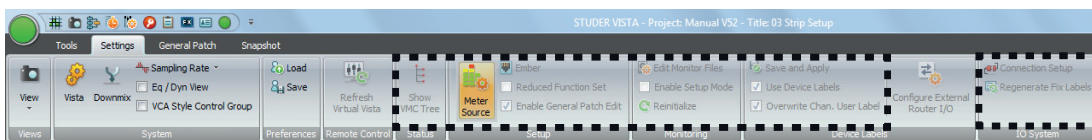
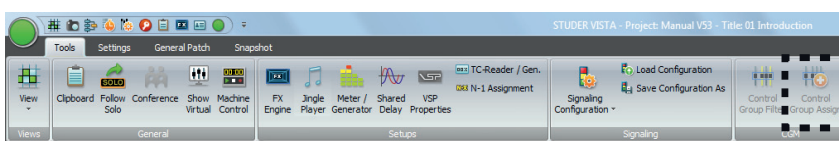

4.7.1 Tools: Control Group Assign

There is a CGM setup window which allows the setup of Control Groups without using the desk operating elements.

It is probably the fastest way to use the desk operating elements for CGM setup, as described in [chapter 2.2.5.9.1](#).

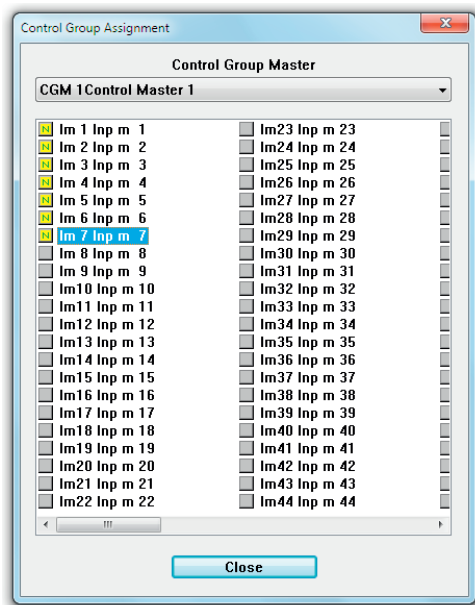

4.7.2 Settings: Show VMC Tree

This feature is primarily used in troubleshooting and typically is not used in normal operation.

Show VMC Tree: This action will bring up the VMC tree View. This page will display a list of all channels, inputs, outputs, busses, and other system elements that are defined within the currently loaded configuration. Double-clicking on one of these items will display the contents of that item's branch. Opening of subsequent branches will take further and further inside the VMC tree. If the item has a changeable parameter, such as EQ high frequency, that parameter may be controlled directly from the VMC tree.

4.7.3 Settings: Meter Source Setup

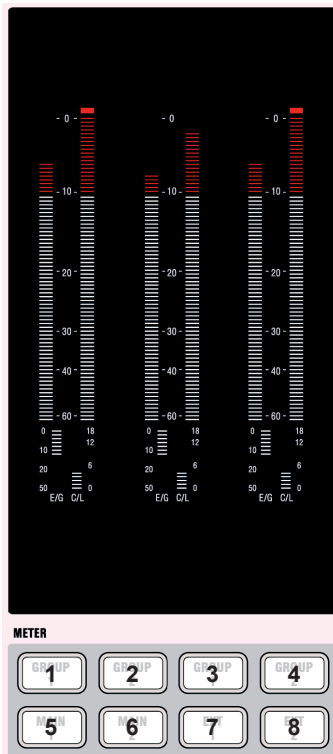

The master level meter assignment is preconfigured using the Graphical Controller. Selection of these preconfigured sources will then be done with the eight hardware **METER** keys below the meter window; these keys have clip-on caps for inserting individual labels mirroring the individual setting. The **METER** key numbering 1-8 is shown left.

In order to change metering sources, the operator needs to be logged-on as a system administrator. This is done in the Settings Ribbon Tab, category Setup. The Meter Source button needs to be pressed.

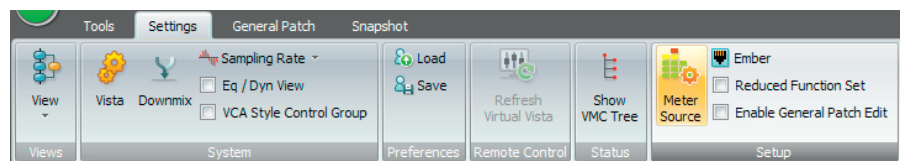

The Meter Source Setup window opens up and displays all necessary parameters to assign metering sources to the six VFD bargraph meters. The steps below describe the setup process :

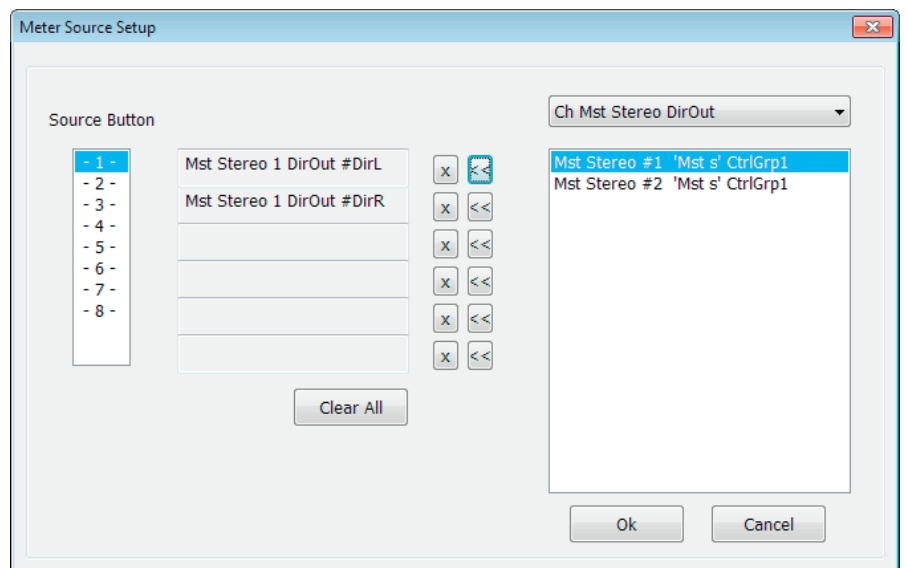

- Step 1** The desired **METER** source selection key is selected with a click.
- Step 2** In the pulldown menu at the right-hand side all sources assignable to the meters are shown. Click to select the source, then click on the << arrow button of the desired bargraph. *Please note that here the numbering is 1 through 6 from top to bottom, while on the actual desk meters it is 1 through 6 from left to right.*
- Step 3** Once this is done for all 6 meters, proceed to the next source selection key

and repeat the procedure until finished.

The setup allows to mix Mono- and Stereo-Sources. The six meters can be configured e.g. with 2 mono sources on the first two meters, a stereo source for meter 3 & 4 and 2 mono sources on meter 5 & 6.

If an error has been made, a single meter strip can be cleared by a click on the **x** button. All meter strips can be cleared at once by clicking the **Clear All** button.

- Step 4** Make sure to click on the **Save** button in order to save the new meter source selector assignment within the current title.

4.7.4 Settings: Ember Control

Ember is a control protocol implementation which allows certain console settings to be controlled over TCP/IP.

Ember control provides seamless integration of Vista consoles with 3rd-party broadcast or newsroom automation systems, such as those from Grass Valley, Ross, Sony and Mosart.

Ember connectivity allows the external equipment to transfer signal labels, and to control input channel levels, solo, mutes, plus Aux send levels and mutes, along with N-X (mix-minus) bus levels and mutes. Master channel levels and mutes can also be addressed, along with Group and Aux master channels. In addition to the control of the mentioned parameters, also console snapshots can be stored and recalled.

Since Ember supports multiconnection setups, it is well suited for installations requiring redundancy concepts.

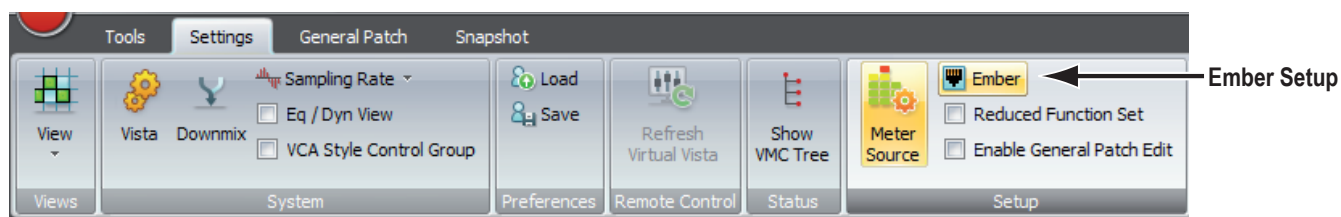

On the Settings ribbon tab, the Ember setup window can be opened.

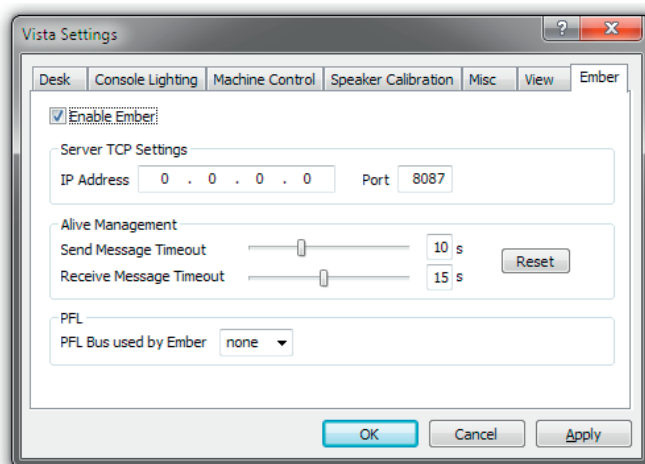

Enter the IP address of the port on the Vista desk PC that you wish to use to connect to the Ember client (automation system). Enter the port, 8087 is default. It is useful to allocate an additional PFL bus for use with Ember to avoid conflict with the desk PFL bus, should both be in use at the same time. It may be necessary to add an additional PFL bus to the DSP config, use the config tool in the usual way. Set the Enable Ember check box and click **Apply**. The automation client must be set to find the Vista desk on the IP address and port you have just entered.

Ember PFL The Ember PFL functionality is decoupled from the Vista desk PFL functionality and thus is also decoupled from the Vista monitoring. The Ember PFL function uses its own PFL bus, which can be patched to an output in order to connect it to a separate monitoring system. This means that an additional, unused PFL bus must be configured for Vista (Vista Configuration) in order to use Ember PFL. For a Vista 1, Vista 5 or Vista V which use “Bus Pfl s 1” for PFL, a second bus “Bus Pfl s 2” needs to be configured for Ember PFL. For a Vista 9 and Vista X which use “Bus Pfl s 1” for main PFL and “Bus Pfl s 2” for ALT PFL, a third bus “Bus Pfl s 3” needs to be configured for Ember PFL. VistaEmber does not automatically detect which PFL bus it has to use. This needs to be configured by setting the PFL bus number.

For a full list of the Ember controllable parameters, please refer to the service manual.

4.7.5 Settings: Reduced Function Set

Whis this setting, the more complex GC functions are hidden from the user GUI. The hidden functions are :

- Fader Ramps
- TC Reader/Generator
- N-1 Assign
- Signaling Configuration
- VSP Properties

4.7.6 Settings: General Patch Edit

When logged in as SysAdmin, the Enable General Patch Edit mode can be activated :

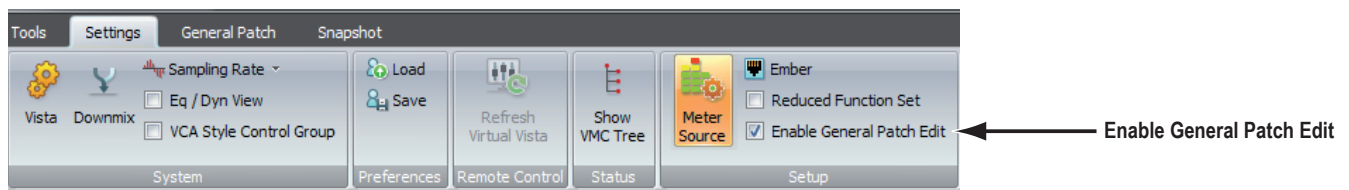

Then, the General Patch ribbon tab shows the Edit General Patch icon :
Now, two things are possible :

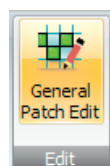

1. Change the place of a patch group
2. Create or edit user patch groups

Here the three areas where the Source groups, Target groups and the Page groups are found :

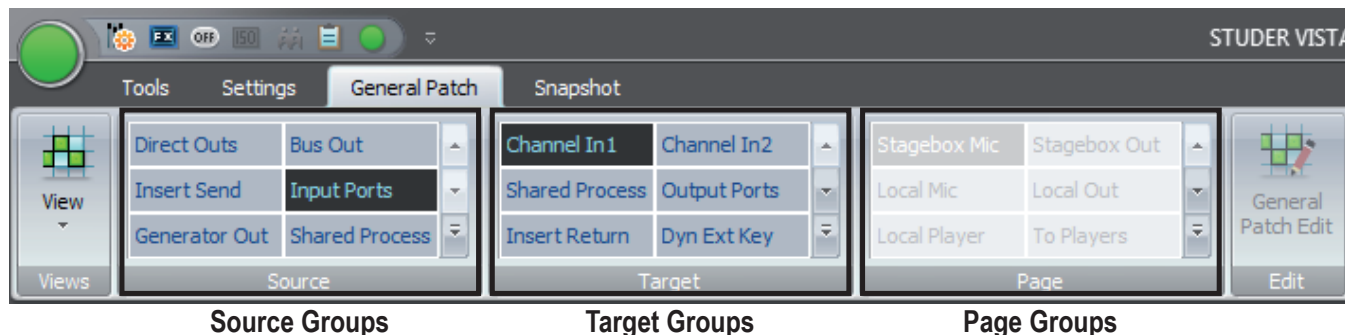

- Source Groups Are patch groups that navigate the source side of the general patch only.
- Target Groups Are patch groups that navigate the target side of the general patch only.
- Page Groups Are patch groups that can navigate both sides of the general patch.

Change the place of a patch group Right-click on the group that you would like to change its place, and select <Pick: Input Ports>

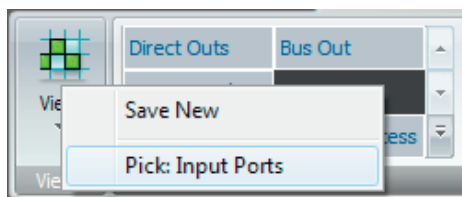

Then go to the desired new position and right-click again.

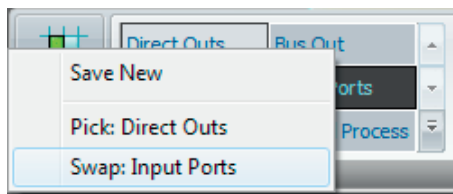

Now, select <Swap: Input Ports>. The two groups then swap their position.

Create or edit User Patch Groups When in “General Patch Edit” mode, the General Patch view changes to Edit View. In addition to the vertical source list on the left side and the horizontal target list at the bottom of the matrix, the patch grid (matrix) disappears and is replaced by additional horizontal source- and target lists with search text-boxes on top. The content of these additional source / target lists matches the Patch Groups selected in the ribbon’s Source and Target patch group frames.

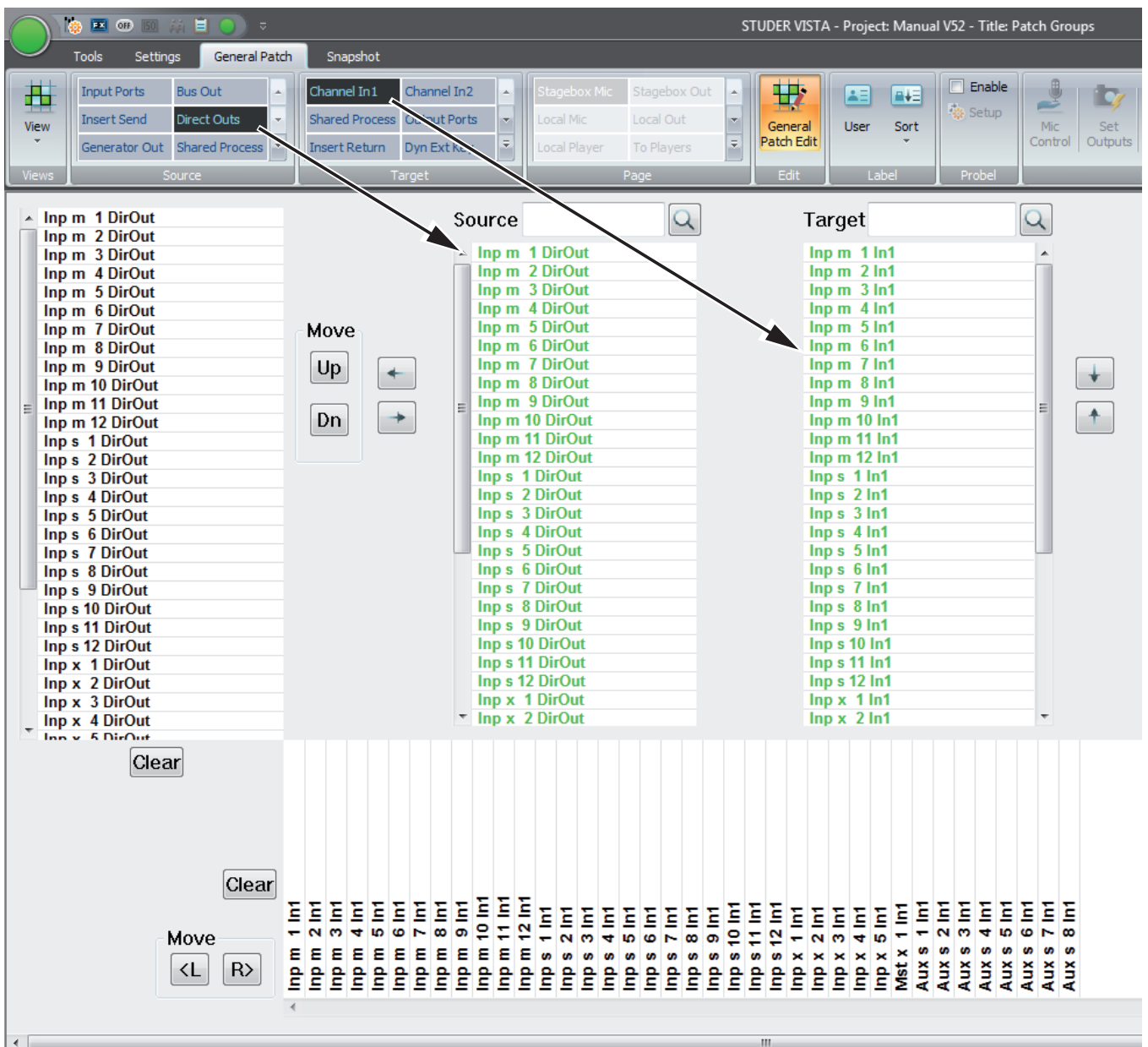

When in the General Patch Edit mode, the vertical source list on the left side and the horizontal target list on the bottom will show the sources and targets within the selected source and target groups which have been chosen before entering the edit mode. These source and target lists are the ones that get stored when saved to a User Patch Group. To start source and target groups from scratch, just press the **Clear** buttons next to the vertical and horizontal lists.

Adding Sources and Targets

The sources and targets shown in the two vertical source and target lists in the middle of the GUI can be assigned to the vertical source list on the left side and the horizontal target list at the bottom. If a source or target gets assigned, its colour changes to green in the two vertical lists in the center. Sources and Targets which are not assigned are in black font.

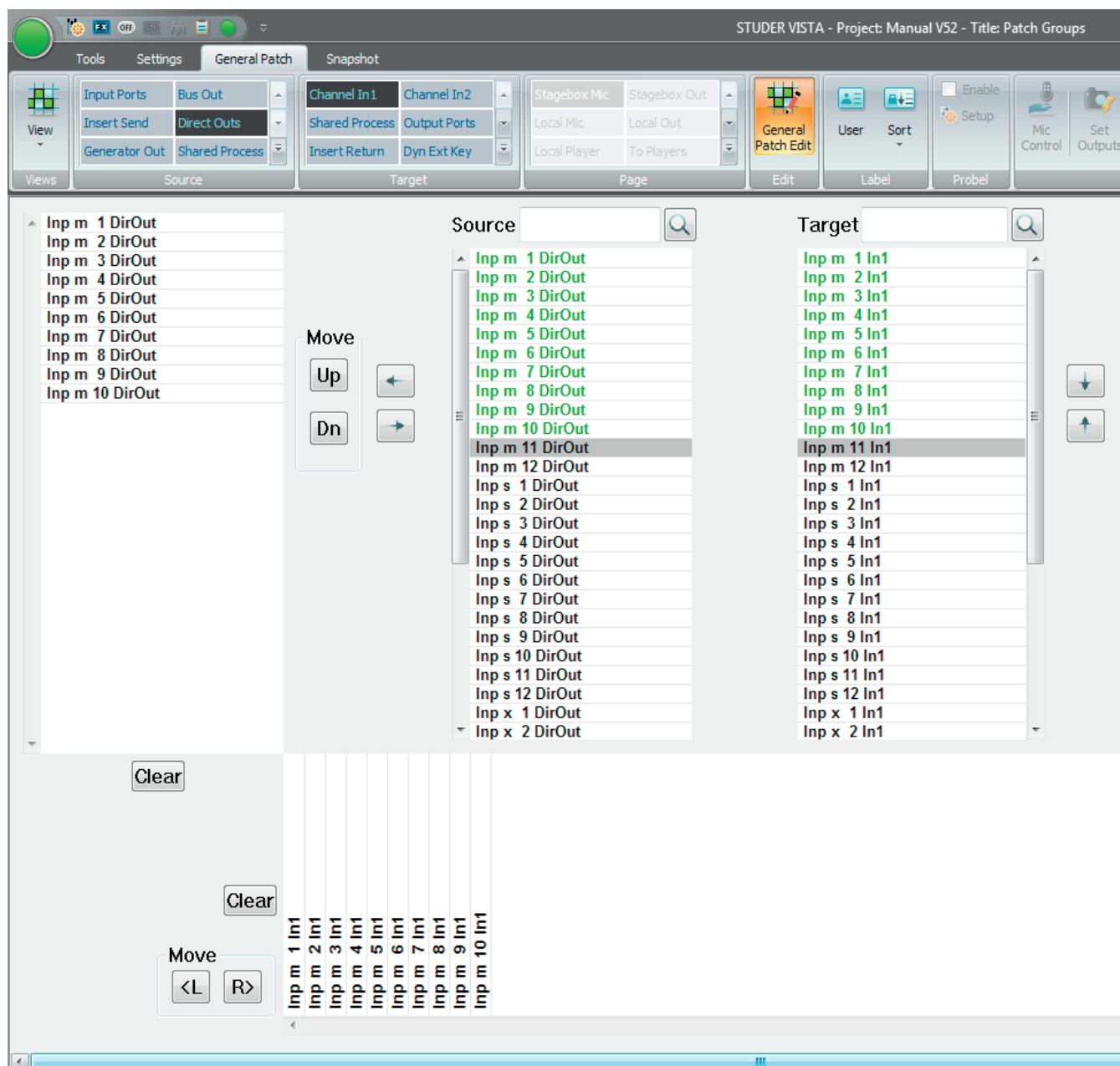

Assign a source or target to the list by double-clicking it. Deassign them by double-clicking on them in the list on the left and bottom. Multiple sources and targets can also be assigned and de-assigned by selecting several items (using Shift or Ctrl on the keyboard) at once and then using the arrow keys on the GUI.

It is possible to mix different source and target types within the Patch Group you are creating. For example, it is possible to create a source list that contains some Bus Outs, some Direct Outs etc.

In Edit mode, you can simply select another source or target Patch Group and add channels from these to the list which you are editing.

By using the Move Up / Move Down buttons, it is possible to change the source / target order of appearance in your edited /created Patch Group.

Save an edited / created User Patch Group

Now the edited source and target lists can be saved as new Source, Target or Page-Groups. If User Patch Groups already exist, it is also possible to save the edited lists by overwriting an existing User Patch Group.

Save as User Source Patch Group

Right-clicking on an existing User Source Group will open a context menu. Select either **Save New** to create a new User Source Patch Group or select **Update** and the User Patch Group you right-clicked will get overwritten. When saving, only the edited vertical source list on the left side will be saved to the User Source Patch Group.

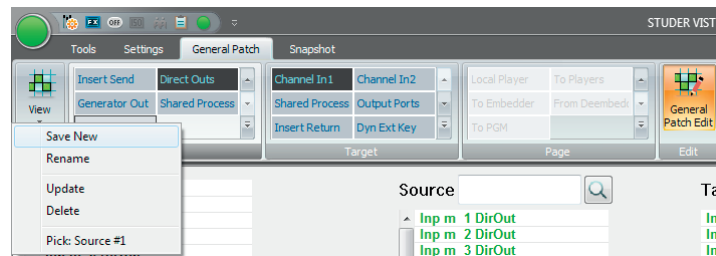

Save as User Target Patch Group

Right-clicking an existing User Target Group will open a context menu. Select either **Save New** to create a new User Target Patch Group or select **Update** and the User Patch Group you right-clicked will get overwritten. When saving, only the edited horizontal target list at the bottom will be saved to the User Target Patch Group.

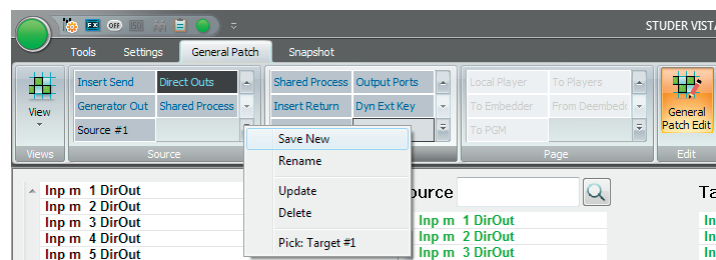

Save as User Page Patch Group

Right-clicking an existing User Page Group will open a context menu. Select either **Save New** to create a new User Page Patch Group or select **Update** and the User Patch Group you right-clicked will get overwritten. When saving, both the edited vertical source list on the left side and the horizontal source list at the bottom will be saved to the User Target Patch Group.

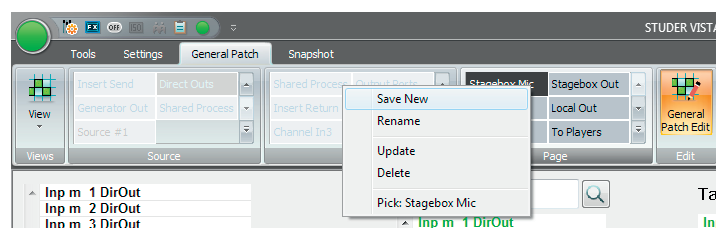

4.7.7 Settings: Edit Monitoring Files

The Monitoring menu item contains several functions regarding the Vista loudspeaker control:

Edit Monitor File: This action brings up the Monitoring Setup editing utility. The title bar will

display the name and location of the currently loaded monitor configuration.

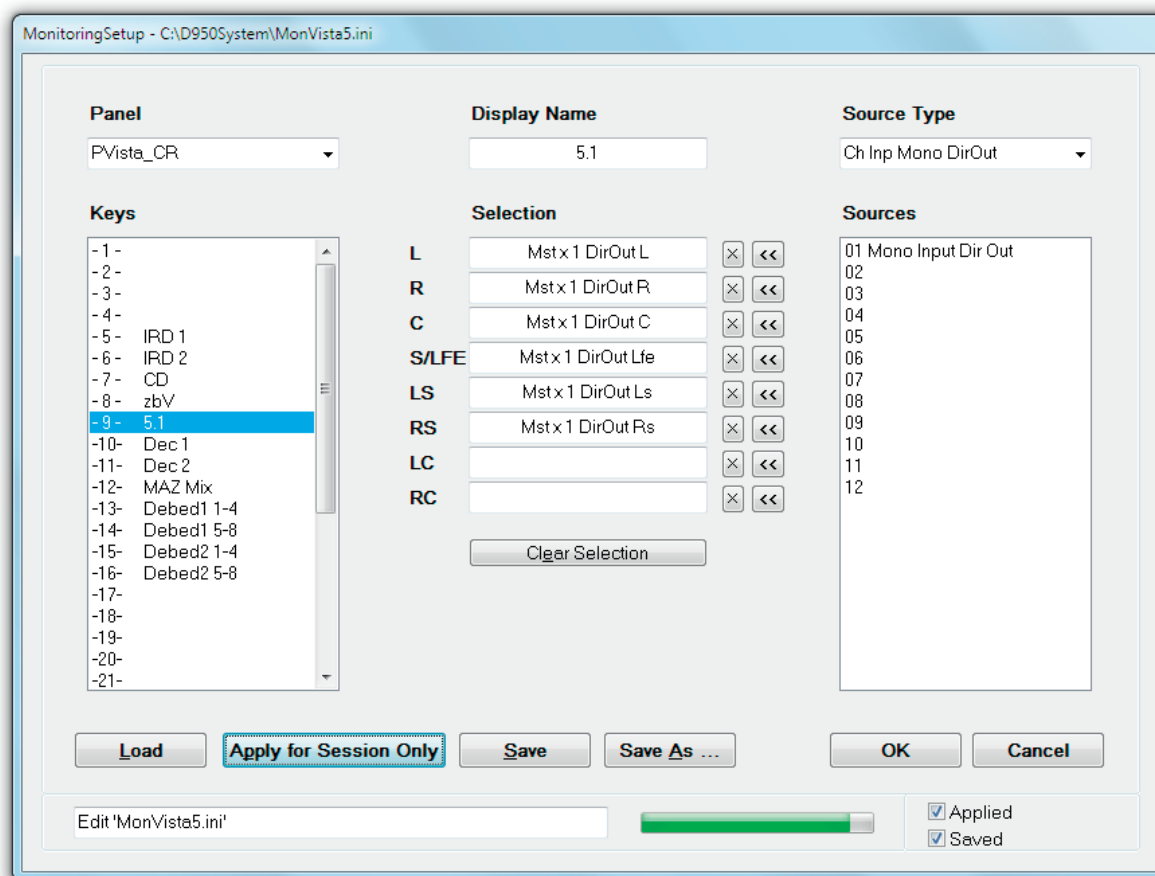

Panel Selection box: This box provides a pop-up menu used to select a control room or studio Assignable Source Selector panel installed in the control surface for editing. The Source Selector keys for the selected panel will be displayed in the Keys box, where they can be selected for editing. The name of the panel may also be edited using this box.

Note: *The four subpanels popping up on the screen upon activated option (experts only!) show up as individual panels with 12 source selectors each.*

Key Selection box: This box is used to select a specific Monitor Source Selector key for editing.

Display Name entry box: This is a name entry box for the selected Source Selector key. It will display the name of the selected key, which can be edited.

Speaker/Source Selection entry boxes: These fields are used to connect a digital audio source (such as a direct output) to a specific loudspeaker feed (such as left, right, center, etc.). This is accomplished by highlighting a source from the Source Selection list and assigning it to the desired loudspeaker feed using the appropriate double-arrow button (<<). When such an assignment is made, the source name will appear in the selected loudspeaker field. Selections may be cleared using the X buttons.

Clear Selection button: This button will clear all Speaker/Source selections made for that Monitor Source Selector key.

Source Type Selection box: This box provides a pop-up menu used to select the type of digital source for assignment (such as a mono master direct output or an AES interface). Once an item has been selected, all the sources of that type will be displayed in the Sources list below.

- Source Selection box:* This box displays a list of digital sources of a specific type that are available for assignment to loudspeaker feeds.
- Load button:* This button brings up a familiar Windows box from which an existing monitor configuration file can be loaded.
- Apply button:* This button applies the current monitor configuration file to the Vista. This is handy when testing a recently edited file or recalling a previously saved file.
- Save and Save As... buttons:* The Save button allows a previously saved monitor configuration file to be updated after editing. The Save As... button allows a new file to be named and created.
- OK and Cancel buttons:* The OK button accepts the current monitor setup and closes the window. Clicking OK does *not* apply or save the monitor configuration file. The Cancel button exits the monitor setup screen.
- Monitor File Name entry box:* This field is used to enter a name for a new monitor Configuration.
- Application Progress indicator:* This meter displays the progress of the loading of the monitor configuration file when it is applied to the console.
- Applied and Saved Status boxes:* These boxes display the status of the current monitor configuration file. If checked, the current file is applied to the console and/or saved.

To create a new monitor configuration file:

- First open the Monitoring Setup utility from the Monitor section of the SysAdmin menu.
- Select the desired Assignable Source Selector panel and key, using the lists on the left.
- Select a source type and source from the lists on the right.
- Highlight the selected source and click on the double-arrow (<<) button next to the desired loudspeaker feed in the Selection boxes. The source name will appear in the selected location. Once a key is selected, its name may be changed using the Display Name field.
- Repeat these steps to complete the necessary assignments. Once finished, the new file can be saved and applied to the console.

Please note that the edited file must be applied to the console before it takes effect.

Existing monitor configuration files can be edited by recalling them with the Load button and using the procedures described above.

4.7.8 Settings: Enable Monitoring Setup-Mode

To allow access to the speaker calibration, the Enable Setup function must be enabled. Please refer to [chapter 4.6.2.1.1](#).

4.7.9 Settings: Reinitialize Monitoring

This action will reinitialize the monitor system and reload the last used monitor configuration file. The monitors will mute during this operation.

4.7.10 Settings : Device Labels (Save and Apply)

This menu item lets you set-up the console for use with Device Labels. It is used for setup only !
For a detailed description, please refer to [chapter 4.4.2.6](#)

4.7.11 Settings: Use DeviceLabels

This option must be checked for using the console with Device Labels. It must be checked (active) for proper Device Labels functionality.
For a detailed description, please refer to [chapter 4.4.2.8](#).

4.7.12 Settings: Overwrite Channel User Label

This option must be checked for using the console with Device Labels. It must be checked (active) for proper Device Labels functionality.
For a detailed description, please refer to [chapter 4.4.2.8](#).

4.7.13 Settings: Configure ExternalRouter I/O

This opens a dialog window for External Router I/O Configuration - but only in the case if external router control is enabled on the system.

4.7.14 Settings: Connection Setup

If this button is pressed, the D23m/D21m I/O system will be reinitialized. This button is not used in normal operating mode, only when changes in the I/O system have happened, this button can be used for trouble shooting.

4.7.15 Settings: Regenerate Intelligent Fix Labels

Audio coming through the D21m I/O components is reaching the core over Studer's proprietary HD (high density) link in case of the SCoreLive. This link is present between the local hub(s) and the SCoreLive. Each link may carry up to 96 audio channels. Instead of displaying these channel numbers in the general patch, the software is able to give more intelligent names to the input and output ports shown in the general patch. You will then see frame numbers as well as card types and channel numbers within each card. This generation is automatically active whenever the D21m I/O system is present and the hub frame is connected to the console via a serial link. However, when recalling a snapshot containing the 'non intelligent' fixed labels (e.g. from older productions), this will overwrite the fixed labels as well and make the 'intelligent fixed labels' disappear. In this case, select **Regenerate Intelligent Fixed Labels** and update this snapshot.

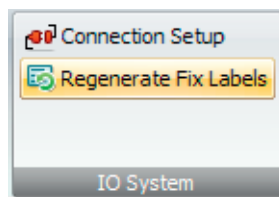

4.7.16 General Patch: Enable Pro-Bel Setup

This option must be checked (active) to enable the ProBel Setup functionality explained below.

4.7.17 General Patch: Pro-Bel Setup

This button starts the Pro-Bel setup process as explained in detail below :

4.7.17.1 3rd-Party Control of Console Patch (Native Pro-Bel P-02/08 Support)

Since SW version 3.5 of the Vista Software, these products are able to support Pro-Bel enabled devices natively, and so a second PC is no more necessary for this functionality. However, we do not recommend that existing installations are altered that are already in use with a second PC for Pro-Bel interfacing. *The explanations below are therefore intended for installation personal and not for the console operators.*

Supported Functionality

Our implementation enables the ability to map certain Pro-Bel connect requests to a set of definable patch connections. The control of patch points is not restricted to set output patch points. It is possible to set any patch points within the console patch upon reception of a Pro-Bel command. The set-up procedure is done from the General Patch screen, where certain patches can be selected (by just selecting the affected targets) and which are being mapped to a Pro-Bel source/destination combination with a single click on a dialog.

Enabling Pro-Bel Setup

In order to activate and see the **Setup Pro-Bel** button on the General Patch window, the system has to be in SysAdmin mode. The SysAdmin menu contains a General Patch sub menu and a **Use Pro-Bel on General Patch** item.



This setting will be written to the `D950System.ini` as well, resulting in the same behavior as if it was edited by hand in the first place. The button will then be visible whenever the system enters SysAdmin mode.

Enabling COM Ports for Use with the Pro-Bel Protocol

Ports that are used for Pro-Bel need to be specified in `D950System.ini` in the `[d950SerialPorts]` section. This gives the possibility to use non-standard data rates and parity settings.

```
[d950SerialPorts]
1= {p} COM1 baud=115200 parity=N data=8 stop=1
2= {b} COM6 baud=38400 parity=E data=8 stop=1
```

'b' is used to indicate Pro-Bel use. Only the COM ports defined in this way will be available in the Pro-Bel set-up dialog.

Pro-Bel Set-up Dialog

With Pro-Bel Setup enabled, the Pro-Bel category displays the additional Setup - button.



When clicking on this button the system brings up the set-up dialog and enters Pro-Bel set-up mode.

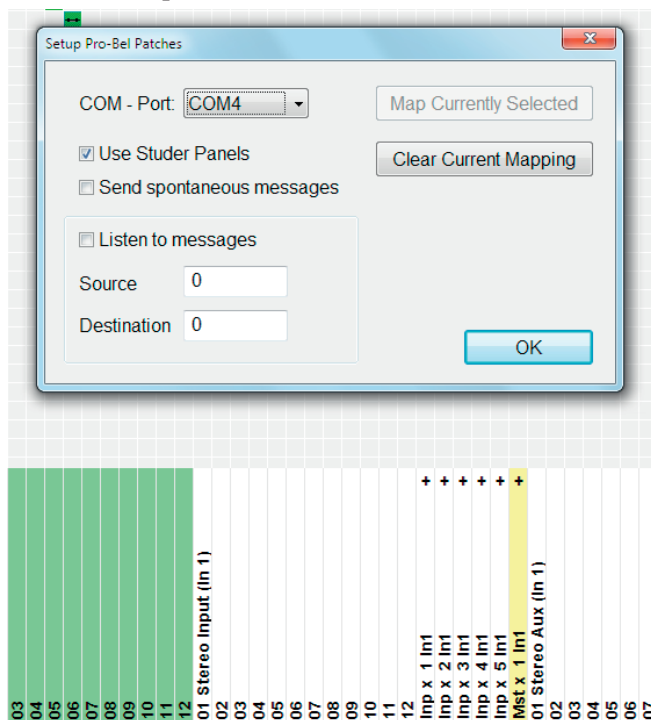

Targets with their respective connections can be selected by clicking on them in the list on the general patch. Selected targets change their color to pink to show their selection state.

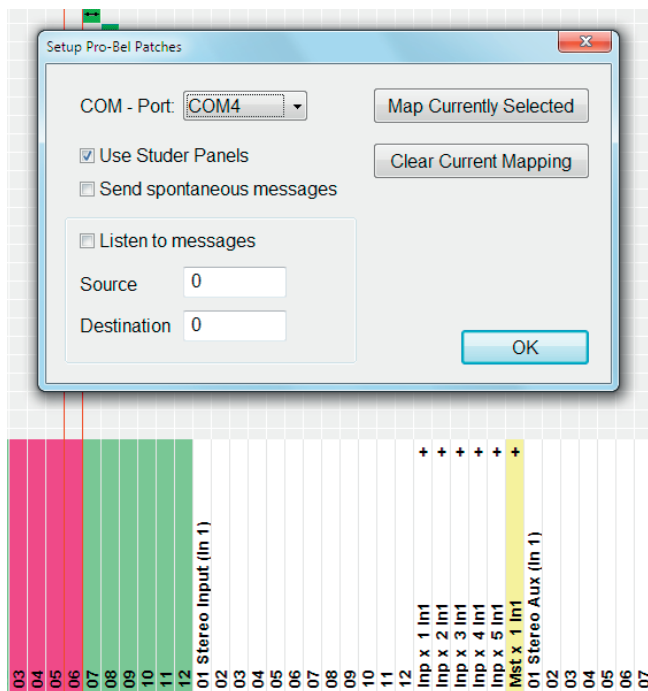

Clicking on the **Map Currently Selected** button maps the patches for the selected targets (the pink-colored ones) to the Pro-Bel connect command specified on the left.

With **Listen to messages** enabled, incoming connect messages are mapped to the edit fields on the dialog. To select targets affected by this connect command simply click on them in the target list of the general patch (color is set to pink).

Make sure to always associate the same Pro-Bel destination to the same set of targets.

Any connection on the patch may be mapped to certain Pro-Bel connect commands. You are not limited just to outputs or inputs!

With **Send spontaneous messages** enabled, the corresponding CONNECTED message is sent whenever one of the defined patch combinations matches the same combination as when they were defined.

Files Used to Save Pro-Bel Set-up

The system creates human-readable files (ini format) in the D950System directory to save the set-up. The files are named according to the COM port used: PortX.Pro-Bel – with X being the COM port used.

Example for a .Pro-Bel File

```
[TARGET_1 SOURCE_6]
Im23 Inp m 23 In1 left=D12L AES B 1 In4L left
Im24 Inp m 24 In1 left=D12L AES B 1 In4L left
[TARGET_1 SOURCE_7]
Im23 Inp m 23 In1 left=D11R AES B 1 In3R left
Im24 Inp m 24 In1 left=D11R AES B 1 In3R left
[TARGET_1 SOURCE_4]
Im23 Inp m 23 In1 left=
Im24 Inp m 24 In1 left=
[TARGET_0 SOURCE_0]
Im23 Inp m 23 In1 left=D11R AES B 1 In3R left
Im24 Inp m 24 In1 left=D11R AES B 1 In3R left
Im25 Inp m 25 In1 left=
Im26 Inp m 26 In1 left=
```

This file basically has a section for each used Source/Target combination. The fixed labels are being used; 'left' is appended for left or mono sources/targets, and 'right' is appended for right sources/targets.

Alternatively a short form of this file may be used in order to support the standard case where all combinations of certain inputs and outputs should be under control of an external device, there is a new file format introduced allowing to only list the required inputs and outputs.

The alternate file format looks as follows:

```
[TARGETS]
1=i 1 B 1 Ch 1 left
[SOURCES]
1=I 1 B 1 Ch 1 left
```

This example defines Pro-Bel destination 1 to be 'i 1' output interface and Pro-Bel source 1 to be 'I 1' output interface using the patch points fixed label syntax.

The format is:

`destination|source=fixed label of patch element + left`

The appended ' left' is kept on purpose in order to keep both formats compatible.

Note: If a source or destination is listed twice by accident, once in the simple format and once in an x/y combination, the simple format has priority, and the x/y listing isn't recognized. This situation is regarded as an error and should not occur in regular cases.

4.7.17.1.1 Pro-Bel P-08 support

In case the user wants to extend the number of controlled patch points to above 1'000 it is recommended to use the Pro-Bel P-08 protocol. This protocol also supports transferring labels from 3rd party router systems at the same time. However, no control over internal patches such as patching from an input port to an input channel is provided. Only one port can be used for P-08. Therefore continue to use P-02 in case of multiple controllers present or if you want to set system internal patches, e.g. channel input patches.

A special mapping file is present in the system translating Vista interfaces to Pro-Bel P-08 commands (no 'fixed labels' used):

```
Pro-Bel SW-P-08 Issue 21
2/1/0/0/0/0,1,1,0,
2/1/0/0/0/1,2,1,0,
2/1/0/1/0/0,2,2,0,
2/1/0/1/0/1,1,1,5,
2/4/0/0/0/0,9,0,0,
2/4/0/0/0/1,0,9,0,
2/4/0/1/0/0,0,0,9,
```

The format is as follows:

IO/InterfaceType/BoardNumber/PortNumber/ChannelNumber/PatchNumber, Index, Matrix, Level

InterfaceType	1 = AES in, 3 = Madi in, 9 = IO21 in 4 = AES out, 8 = Madi out, 10 = IO21 out
BoardNumber	Certain interfaces use board numbers
PortNumber	Certain interfaces use port numbers
ChannelNumber	Interfaces do not use channel numbers and it's usually 0
PatchNumber	The zero-based index of the patch of the selected board and port
Index, Matrix	Index and Matrix as defined in the Probel specification
Level	Level is evaluated for sources only. <i>As this might be used differently with OnAir 3000 systems, we recommend using 0 for the Level.</i>

4.7.17.1.2 Exclude Certain Patch Targets from Being Changed by Snapshots

Some customers are using our consoles as audio routers for other studio installations, controlling the internal router by protocols such as Pro-Bel or ARMI. When recalling console snapshots, the patch points set by these devices are reset to the value of the snapshot, even if this was not always requested. Since software release 3.4 it is possible to define certain patch targets as 'isolated from snapshot recalls'. In other words, the user defines the patch outputs are controlled by Pro-Bel/ARMI devices and therefore makes those targets completely independent from snapshot recalls by the console operator. This set-up is typically done once on a system. See service instructions for information on how to set-up this isolation.

4.7.17.1.3 Label Import from 3rd-Party Systems

In addition to getting patch control it is possible to exchange label information with external router systems, such as Pro-Bel and Grass Valley. Using a serial connection, a permanent label exchange can be set up in such a way that the 'device labels' used in Vista and D950 systems are permanently overwritten by received labels from the 3rd party router. This means that you will automatically see the name of the original sources on your channel strip, even if a large routing system is placed before your console.

Studer supports two label exchange protocols: Pro-Bel SW-P-08 and Grass Valley Group Series 7000. Normally this feature is only used for label *import* from the external devices. However, when using the Pro-Bel SW-P-08 proto-

col, also *export* of output interface labels is supported. It is therefore possible to connect two Vistas together and get the labels automatically from one Vista transferred to the second.

Note: The Pro-Bel P-08 interface also allows patch control and not only transfer of labels.

4.7.17.1.4 Support of External Monitoring Source Selector Panels

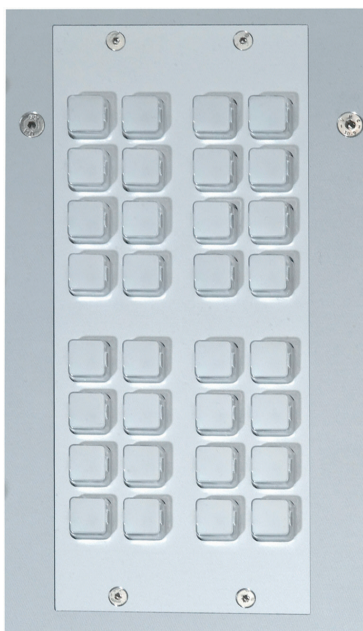

As an alternative to controlling patch points of the console by using 3rd-party controllers (Pro-Bel protocol), Studer offers a 'mini' Pro-Bel controller module. The module may be mounted within the Vista console or anywhere externally. It hosts 32 freely programmable keys to set any number of patch points within the console. Each key may be defined to set a certain patch point (or a set of patch points.) The keys on the hardware panel are illuminated, if all of the defined patch points are currently set. As soon as one of them is cleared or changed, the key gets dark. This intelligence allows free grouping of the 32 keys to e.g. 16 groups of two sources each, or to one single group of 32 sources. Any combination in between is possible. It is also possible to use 16 keys as one group while using the remaining keys as two groups of eight, for example.

If a set of keys are setting patch points to the same destination they are automatically recognized as a group and therefore their illumination will automatically indicate the correct patch state. Rule: A key is illuminated as long as all defined patch points are set. If at least one of them is changed (e.g. by pressing another source selector or by the console's touch pad) the key becomes dark.

Note: Switching patch points is not only possible to outputs of the console, but everywhere within the patch (e.g. input patches to input channels or inserts). Therefore the Studer panel may also be used to switch any number of input patches of the console to different inputs.

Patch Point Isolation

These patch points cannot be isolated against changes by snapshot recalls, unless the inputs of the channels are isolated. The general function of isolating patch points against snapshot recalls may be applied to output patches only.

Patch Mapping Setup

The setup on the console side happens in the same way as when setting up normal Pro-Bel control. The panel itself needs an address set. This address will guarantee that multiple panels may work at the same time. Multiple panels may be connected to one serial port of the console. Please refer to the service manual for more details.

4.7.18 Snapshot: Output Snapshot Isolation

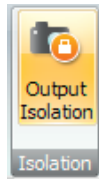

By pressing the button Output Isolation, output patch connections can be protected against changes from snapshot recalls.

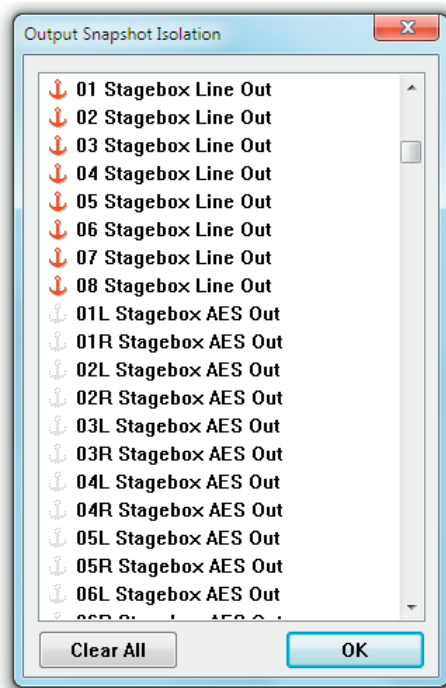

4.8 Fifth Level: The Surveyor

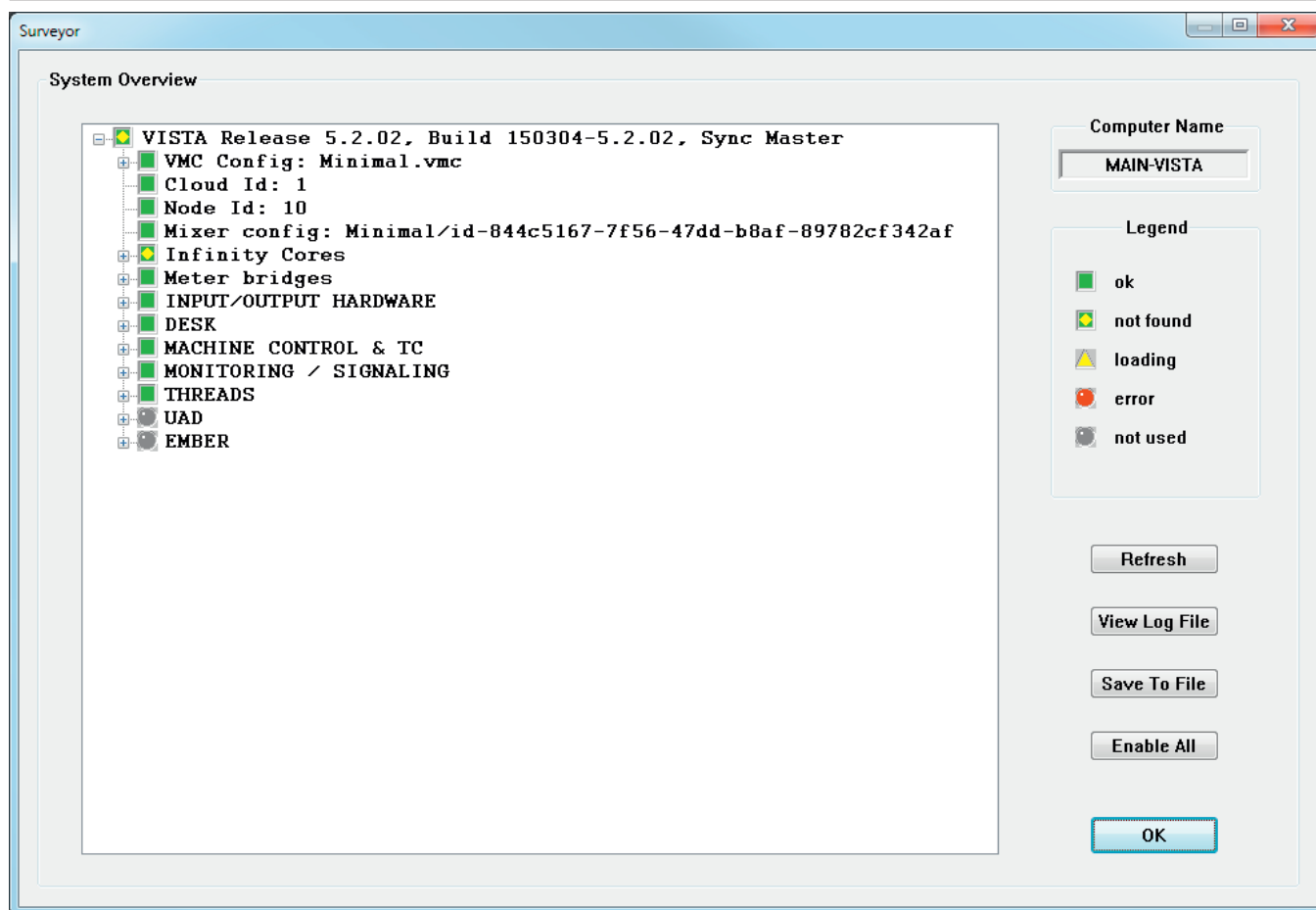

Vista constantly monitors the status of all major hardware and software systems. This information is provided to the user via the Surveyor. The Surveyor is also the primary diagnostic tool used for troubleshooting and fault finding. The Surveyor displays its information in two ways:

- The Icon/Button shown on the left hand side of the Ribbon menu bar;
- The Surveyor page.

The Surveyor Icon/Button:

The Surveyor Icon/Application Menu Button is always located in the Ribbon menu bar. It is intended to keep the operator informed about general system status. The icon changes to indicate the overall condition of the Vista. These indications are as follows:



Grey circle: The system is starting up.



Green circle: The system is working and OK.



Green circle with yellow exclamation mark: Not Found. A system element cannot be found. This is sometimes seen while a configuration is loading. If this icon remains on, a problem is indicated



Red circle: Error. An error, fault, or failure is detected in the system. If this icon remains on, a problem is indicated..

Surveyor Page: The Surveyor page may be opened from the SysAdmin menu or by clicking on the Surveyor button. The main window contains all the major system elements displayed as a directory tree. The status icon at the start of each directory indicates the general status of its contents. These icons utilize the same indication system as the Surveyor button (see above).



Green square: OK. This system element operates normally;



Green square with yellow diamond: Not Found. A system element cannot be found. This is sometimes seen while a configuration is loading. If this icon remains on, a problem is indicated.



Tip

Sometimes an element cannot be found simply because it has not been switched on.



Yellow triangle: Loading. This system element is booting (info in the status bar);



Red circle: Error. An error, fault, or failure is detected in this system element.



Grey circle: Not Used. A system element is defined but is not in use.

If all elements display the OK icon (green square), the system will operate normally. If any of the directories display the Error icon, it can be opened to determine which of its contents has a problem. Since some system elements have many subsystems, several nested subdirectories might be contained within the main directories. As with the typical Windows directory system, directories that contain subdirectories have a '+' symbol on the left of the status icons. To open these directories either click on the '+' symbol or double-click the directory name or status icon. It might be necessary to open several directories to find the specific element that is having a problem.

Surveyor Tools: The Surveyor features several tools to enhance its operation. These are available as buttons on the Surveyor page:

- *Refresh:* Real-time updates of system element icons are not provided when the Surveyor page is open. If a fault is corrected during troubleshooting, the system must be re-interrogated before the Surveyor page will display the result. Clicking the Refresh button will survey the entire system and display the current the status of all elements.
- *View Log File:* This tool allows the Vista log files to be viewed from within the Surveyor.
- *Save Log File:* This button saves the current Vista log file.
- *Enable All:* It is possible to tell the Surveyor to ignore some problems by right-clicking on one of the red symbols. This will make the main symbol in the task bar remain green, even if there is an error reported in some sub-area. 'Enable All' clears these exceptions and makes the Surveyor work as usual. *Inactivated sub-areas are always re-activated upon system startup for safety reasons.*
- *OK:* Clicking this button will close the Surveyor page.

Surveyor Information: When it is initially opened, the Surveyor displays some information without the need to open any directories or subdirectories:

- *Computer Name:* This field displays the name of the PC that is being used to control the Vista system;

- *Vista System*: This is the main directory in the Surveyor, which contains all of the other system element subdirectories. Its name displays the Vista software Application Release number (version) and the Build number. This directory will always be open to show the primary system element subdirectories (and their status) when the Surveyor is opened;
- *VMC Session Config*: This item displays the currently loaded Session Configuration file in a directory name format, such as: C:\D950SYSTEM\VMC directory name\VMC name.vmc.

☞ **Tip** Other current system files (such as monitor files) may be found in the Surveyor, but will be nested within subdirectories.

CHAPTER

5 D21m Option Card and Stagebox Handling 3

5.1 D21m Option Cards for Vista 1 3

5.2 Vista 1 I/O Ports..... 4

5.2.1 Insert a D21m Card 4

5.2.2 Connect a Stagebox..... 5

5 D21M OPTION CARD AND STAGEBOX HANDLING

5.1 D21m Option Cards for Vista 1

Vista 1 provides a D21m extension slot at the rear. It is a dual D21m card slot, where either one dual-slot or one or two single-slot cards can be inserted. Any card of the D21m range available for Vista mixing systems can be used for Vista 1.

Please note, that also the D23m Dual MADi card can be used in the option slot of the Vista 1.

Name	I/O Format	# of Console Input Channels	# of Console Output Channels	Connector Type	Width (Slots)	Order No.
Analog I/O Cards						
Mic/Line Input (incl. Dir. Outs)	Mic/Line	4	(4 Dir. Outs)	D25 f	single	A949.0427
Analog Insert	Line	4	4	D25 f	single	A949.0428
HD Mic/Line Input with Input Transformers (incl. Dir. Outs)	Mic/Line	4	(4 Dir. Outs)	D25 f	single	A949.0447
Analog Line In	Line	8	–	D25 f	single	A949.0421
Analog Line Out	Line	–	8	D25 f	single	A949.0420
Digital I/O Cards						
AES I/O M2 (no SRCs)	AES/EBU	8 stereo (16 mono)	8 stereo (16 mono)	2 × D25 f	double	A949.0454
AES I/O M2 (Input SRCs)	AES/EBU	8 stereo (16 mono)	8 stereo (16 mono)	2 × D25 f	double	A949.0455
AES I/O M2 (In/Out SRCs)	AES/EBU	8 stereo (16 mono)	8 stereo (16 mono)	2 × D25 f; ext. sync XLR	double	A949.0456
MADI I/O */**	MADI	64 at 48 kHz (32 with redundancy, 64 without redundancy at 96 kHz)	64 at 48 kHz (32 with redundancy, 64 without redundancy at 96 kHz)	SC (optical)	double	A949.0430
				SC (optical)		A949.0431
				2 × RJ45		A949.0433
Dual MADI I/O (D23m) */**	MADI	128 at 48 kHz (64 with redundancy, 128 without redundancy at 96 kHz)	128 at 48 kHz (64 with redundancy, 128 without redundancy at 96 kHz)	4 × SFP	double	5045304
ADAT I/O						
ADAT I/O	ADAT	16 at 48 kHz (8 at 96 kHz)	16 at 48 kHz (8 at 96 kHz)	TOSLINK (optical)	single	A949.0425 A949.0429
TDIF I/O	TDIF	16 at 48 kHz (8 at 96 kHz)	16 at 48 kHz (8 at 96 kHz)	2 × D25 f	double	A949.0426
3G/HD/SD SDI Input	3G/SD/HD	8/16	–	2 × BNC	single	A949.0452
HD/SD SDI I/O	HD/SD	8	8	4 × BNC	single	A949.0442
3G/HD/SD SDI I/O	3G/HD/SD	16	16	4 × BNC	single	A949.0451
Dolby® E/Digital Decoder	AES/EBU	8	2 stereo (4 mono)	D15 f	single	A949.0443
			4 stereo (8 mono)			A949.0444
CobraNet® I/O	CobraNet	32	32	2 × RJ45	single	A949.0445
Aviom A-Net® Output	A-Net	–	16	RJ45	single	A949.0446
EtherSound® I/O *	AoIP	64	64	3 × RJ45	double	–
Rocknet® I/O	RockNet	64/48 (dep. on sw mode)	32/48 (dep. on sw mode)	3 × RJ45, BNC, USB	double	–
BCD DTMF Dec./Glits Gen.	Internal	16	8	–	single	5029584
BCD Blits/Glits Gen.	Internal	–	8	–	single	5029586
BCD Minimixer M2	Internal	32	32	–	single	5029587
Livewire® I/O	AoIP	2 × 16	2 × 16	2 × RJ45	single	5014376
Dante®	AoIP	64	64	2 × RJ45, BNC	double	5045044
BLU Link®	BLU Link	32	32	2 × RJ45, D9 f	single	5033340
Intercom BNC	AES/EBU	8	8	4 × BNC	single	5037475
Intercom D-Type	AES/EBU	8	8	D25 f	single	5037474
Non-Audio I/O Cards						
GPIO w. Open-Collector Outp.	GPIO	16	16	2 × D25 f	double	A949.0435
GPIO w. Relay Outputs	GPIO	16	16	2 × D37 f	double	A949.0436

* The number of channels transmitted to and from a card may be defined in steps of 8 channels by using DIP switches on the card.

** Regardless of the number of channels defined with the DIP switches, a switch on the front panel switches the MADI protocol between the standard 56-channel format and the extended 64-channel format. Therefore this switch may have to be set to '56 channel' protocol in order to operate correctly with third-party MADI devices. In this case the number of channels set internally should not exceed 56.

5.2 Vista 1 I/O Ports

The number of input and output ports is defined in the DSP session configuration. The Vista 1 comes with several factory-set configuration templates that have, by default, 32 input ports and 16 output ports for the D21m card slots. These I/O port configurations are ideal for the use with a MADI I/O card to establish the connection to a Studer Compact Stagebox.

Template titles for these configurations are, e.g. 'Vista1 Mono', 'Vista1 Stereo', 'Vista1 Surround', 'Vista1 FOH' and 'Vista1 Monitor'.

Input Ports
Output Ports

The Compact Stagebox I/O ports have the following device labels predefined:
Stagebox 1 - Stagebox 32
Stage Out 1 - Stage Out 16

When using D21m cards *without* a Compact Stagebox, the I/O count is also limited to 32 inputs and 16 outputs, which must be considered when D21m cards with a larger total number of I/O are used.

If the full 64 in/64 out of a D21m card need to be accessed, there are alternative DSP session configuration templates predefined. These are the configurations with an added 'D21' in the template's title: 'Vista1 Monod21', 'Vista1 Stereod21', 'Vista1 Surroundd21', etc.

As there are no template titles for the above 64/64 configurations, they can be loaded and a new title needs to be created from scratch or merged with an existing file. When such a new title is created, the device label preset as well as a generic console start preset will already be found in the preset menu because these are saved with the DSP session configurations.

5.2.1 Insert a D21m Card



First of all: Power the console down and unplug it from the mains.

Remove the blank panel(s) and insert the D21m card(s). After powering up again and starting the Vista application, the recessed **RECONFIG** button must be pressed.

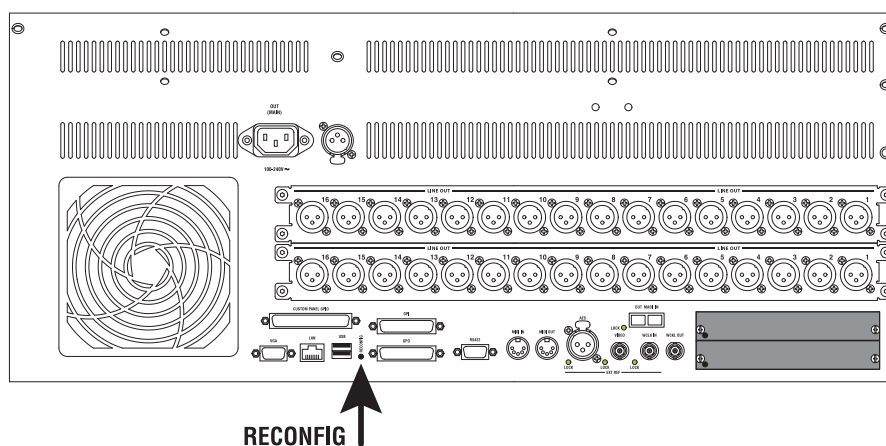

A message window may appear. Click on the Ok button and wait for a couple of seconds until a new message window **I/O Hardware change detected – Wait for default I/O setup to reappear?** appears. There are three option buttons: Ok, Use for this session only and Store as new default. Click on Store as new default. Again, after waiting for a few seconds the Surveyor icon will become green and the added card(s) will be visible in the Surveyor details. The D21m card(s) are now ready to be used.

More information on the D21m I/O system can be found in the D21m Operating Instructions manual.

5.2.2 Connect a Stagebox

Vista 1 is predefined for use with a Studer Compact Stagebox featuring 32 Mic/Line inputs and 16 outputs. If this Compact Stagebox is used, a D21m MADI I/O card matching the MADI HD card of the Stagebox needs to be inserted into the D21m option slot.

To use the Vista 1 with any other type of Stagebox, insert a D21m MADI I/O card (multi-mode, single-mode or electrical) matching the MADI HD card of the Stagebox.

Note: The DIP switches of the MADI card should be set to match the actual number of channels provided from and to the Stagebox.

If the number of I/O ports required by the Stagebox is higher than 32/16, it is recommended to use the DSP session configurations having 64/64 I/O available for the D21m extension slot: ‘Vista1 Monod21’, ‘Vista1 Stereod21’, ‘Vista1 Surroundd21’, etc.

Once the local MADI card has been added to the desk as explained in chapter 5.2.1, it will be shown in the Surveyor. After connecting and powering up the Stagebox, it will automatically appear in the Surveyor as an additional I/O entity named Remotebox.

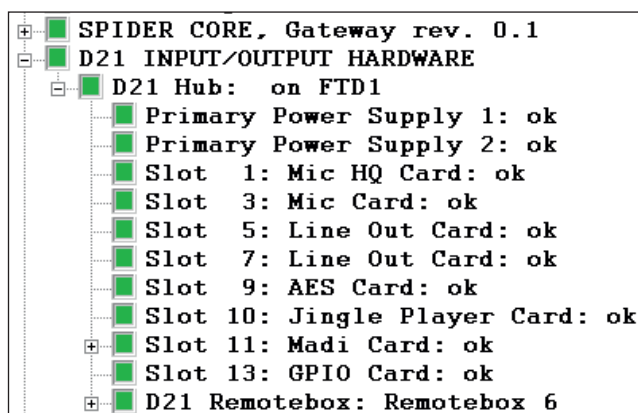

When now patching microphone inputs from the remote stagebox to any of the console’s input channels and selecting **GLOBAL VIEW - MIC CTRL**, the microphone preamp control parameters appear on the Vistonics screen. Now the input gain, 48 V phantom power and the high-pass (low-cut) filter can now be controlled remotely from the desk.

Should yellow triangles appear in the above dialog close and re-start the Vista application.

More information on the Compact Stagebox can be found in the Compact Stagebox Operating Instructions manual.

CHAPTER 6

6	DSP Configurations	3
6.1	Available Templates	3
6.2	Working with the Provided Templates.....	5
6.3	Monitoring/Talkback Inputs/Outputs.....	6
6.3.1	‘Vista 1 Mono/Stereo/FOH/Monitor’ Configuration Templates	6
6.3.2	‘Vista 1 Surround’ Configuration Template	7

6 DSP CONFIGURATIONS

As an exception to other Vista series consoles, the Vista 1 comes with a choice of several different configuration templates currently available. They can be loaded depending on the application that the mixing console is intended for.

These preconfigured DSP structures may be considered as templates that differ from each other in the channel format; they all run at 48 kHz and 44.1 kHz sampling rates. The available DSP resources are used to full capacity with every session configuration. Depending on the channel-format, more or less input channels and busses can be assigned for your particular application.

There are session configurations designed for the use in broadcast production applications. Of course these configurations may be used also for other applications as well, since normally other applications only use a subset of what is available in these three configurations.

Further configurations are intended for live public address (PA) applications and stand out from the others by a high AUX bus count.

Please note that the assignment of the monitoring and talkback inputs/outputs to the console's rear panel connectors is different whether the Mono/Stereo/PA configuration or the Surround configuration is currently loaded (for details refer to [chapter 6.3](#)).

6.1 Available Templates

At the time this document was compiled, the templates detailed in this chapter were available.

Updates Additional configuration templates will be made available in due course; they will then be downloadable from the Studer web site (www.studer.ch). Configuration details will also be available for download. It is recommended that they are appended at the end of this chapter if you have a printed manual.

Vista 1 MONO Template

This configuration features a large number of mono inputs that can be mixed to two stereo masters. It can be used when all other configs do not provide sufficient input channels, for productions that require many discrete microphone inputs.

Path Type	Inputs Mono	Inputs Stereo	Inputs 5.1	Groups Mono	Groups Stereo	Groups 5.1	Masters Mono	Masters Stereo	Masters 5.1	AUX Mono	AUX Stereo	Control Groups	Downmix	N-X Bus	Multitrack Bus
Qty	110	-	-	8	-	-	-	2	-	16	-	10	-	-	-
Processing Blocks	ALL	-	-	GEQ DYN	-	-	-	DYN	-	GEQ	-	-	-	-	-

Vista 1 STEREO Template

The stereo configuration features a selection of channels necessary for a stereo production. Groups and masters are in stereo, and also mix-minus (N-X) busses are provided.

Path Type	Inputs Mono	Inputs Stereo	Inputs 5.1	Groups Mono	Groups Stereo	Groups 5.1	Masters Mono	Masters Stereo	Masters 5.1	AUX Mono	AUX Stereo	Control Groups	Downmix	N-X Bus	Multitrack Bus
Qty	80	12	-	-	8	-	-	4	-	8	4	10	-	8	-
Processing Blocks	ALL	ALL	-	-	ALL	-	-	DYN	-	GEQ	-	-	-	-	-

Vista 1 Surround Template

The surround configuration features a good mix of channels necessary for a surround production. Groups and masters are in 5.1 surround format, also mix minus busses are provided. Four automatic surround-to-stereo and to-mono downmixers are also available in this DSP structure. Two mono groups are provided for commentary mixing in surround productions.

Path Type	Inputs Mono	Inputs Stereo	Inputs 5.1	Groups Mono	Groups Stereo	Groups 5.1	Masters Mono	Masters Stereo	Masters 5.1	AUX Mono	AUX Stereo	Control Groups	Downmix	N-X Bus	Multitrack Bus
Qty	32	8	6	2	-	4	-	-	2	6	4	10	6	6	-
Processing Blocks	ALL	ALL	ALL	ALL	-	ALL	-	-	DYN	PAR. EQ	None	-	-	-	-

Vista 1 FOH / Monitor Templates

There are two session configurations provided for public address (PA) applications, for which the console is either used at the FOH position to provide sound for a large audience, or near the stage to provide monitoring mixes for the performing artists. A large number of AUX busses is provided, all of them equipped with graphic equalizers (GEQ).

FOH:

Path Type	Inputs Mono	Inputs Stereo	Inputs 5.1	Groups Mono	Groups Stereo	Groups 5.1	Masters Mono	Masters Stereo	Masters 5.1	AUX Mono	AUX Stereo	Control Groups	Downmix	N-X Bus	Multitrack Bus
Qty	150	10	-	-	-	-	4	6	-	10	-	32	-	-	-
Processing Blocks	EQ DEL INS	EQ DEL INS	-	-	-	-	ALL	ALL	-	GEQ DEL	-	-	-	-	-

Monitor:

Path Type	Inputs Mono	Inputs Stereo	Inputs 5.1	Groups Mono	Groups Stereo	Groups 5.1	Masters Mono	Masters Stereo	Masters 5.1	AUX Mono	AUX Stereo	Control Groups	Downmix	N-X Bus	Multitrack Bus
Qty	85	10	-	-	-	-	10	-	-	15	15	30	-	-	-
Processing Blocks	ALL	ALL	-	-	-	-	INS	-	-	GEQ	GEQ	-	-	-	-

6.2 Working with the Provided Templates

The session configurations mentioned above are per default available on the Vista 1 console. The easiest way of working with one of these configurations is to start from one of the template titles that are provided with the console, as shown below.

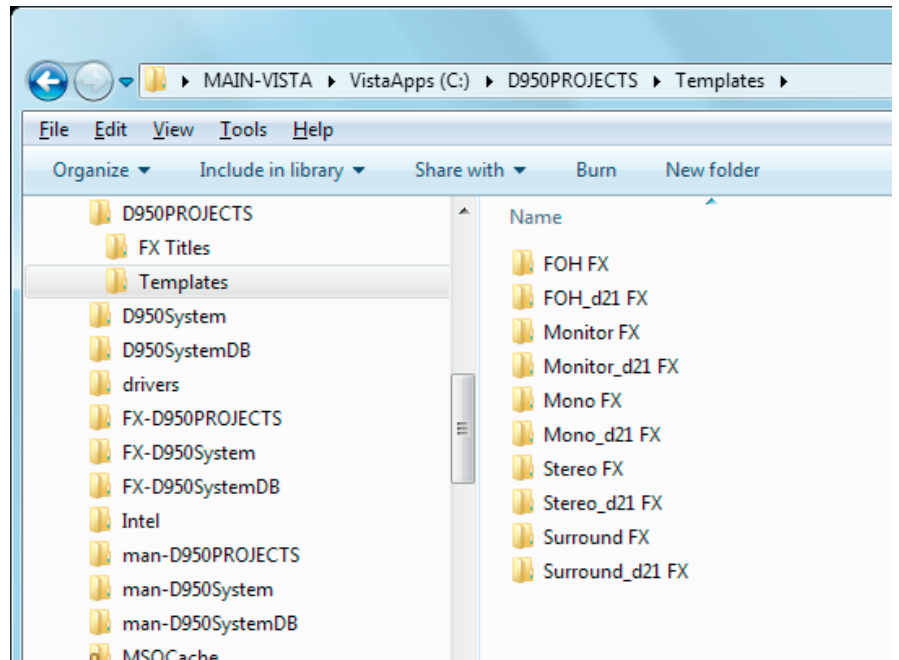

By opening one of the title templates, the appropriate DSP configuration is automatically loaded into the Vista 1's DSP engine.

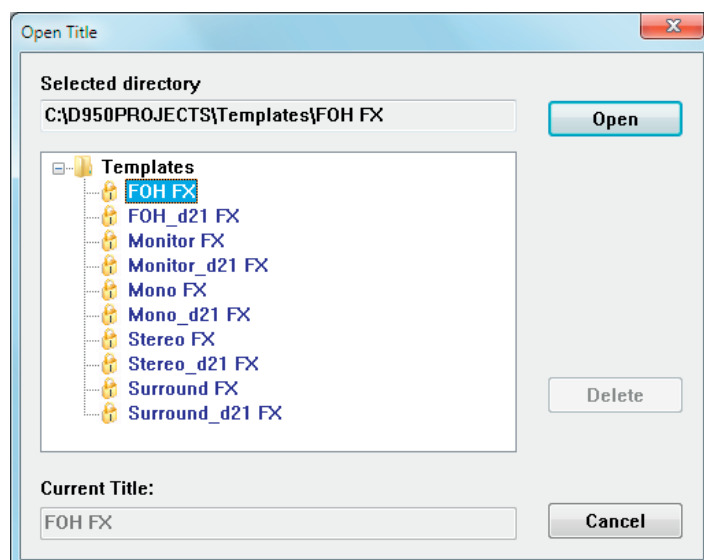
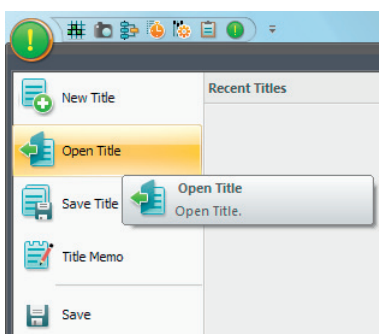

The recommended workflow is to open the desired title template, to save it under a new project folder with the name of the current production.

When a template has been selected to open, the system only allows to open a copy of the template, that needs to be saved with a new title name :

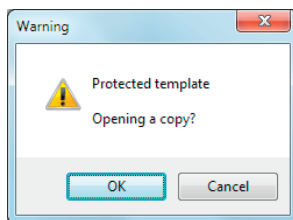

After clicking the OK button, you can create a new project folder and give the title a new name.

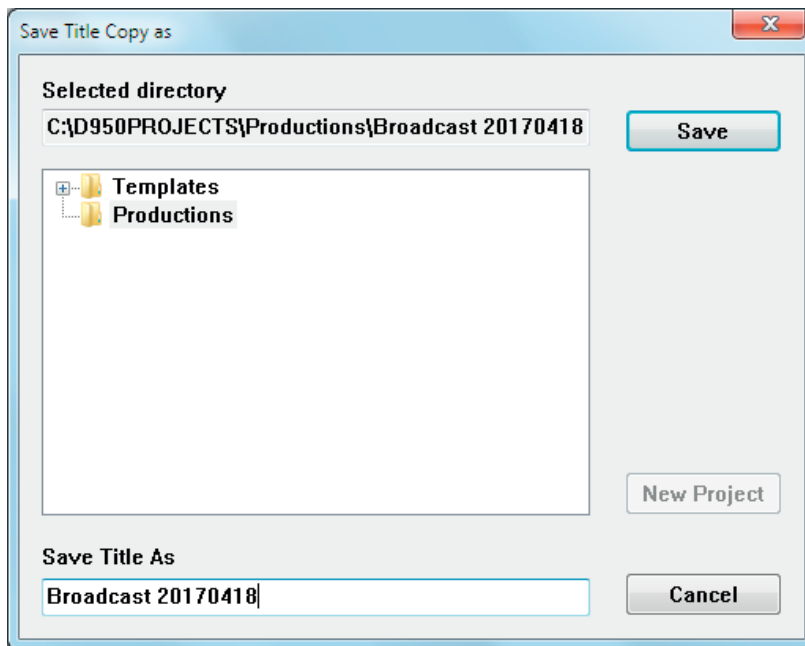

This workflow keeps the original template titles, and their states remain unchanged for future use.

6.3 Monitoring/Talkback Inputs/Outputs

6.3.1 'Vista 1 Mono/Stereo/FOH/Monitor' Configuration Templates

The monitoring and TB I/O connector assignment for the mono, stereo and PA configurations is identical, according to the information given below.

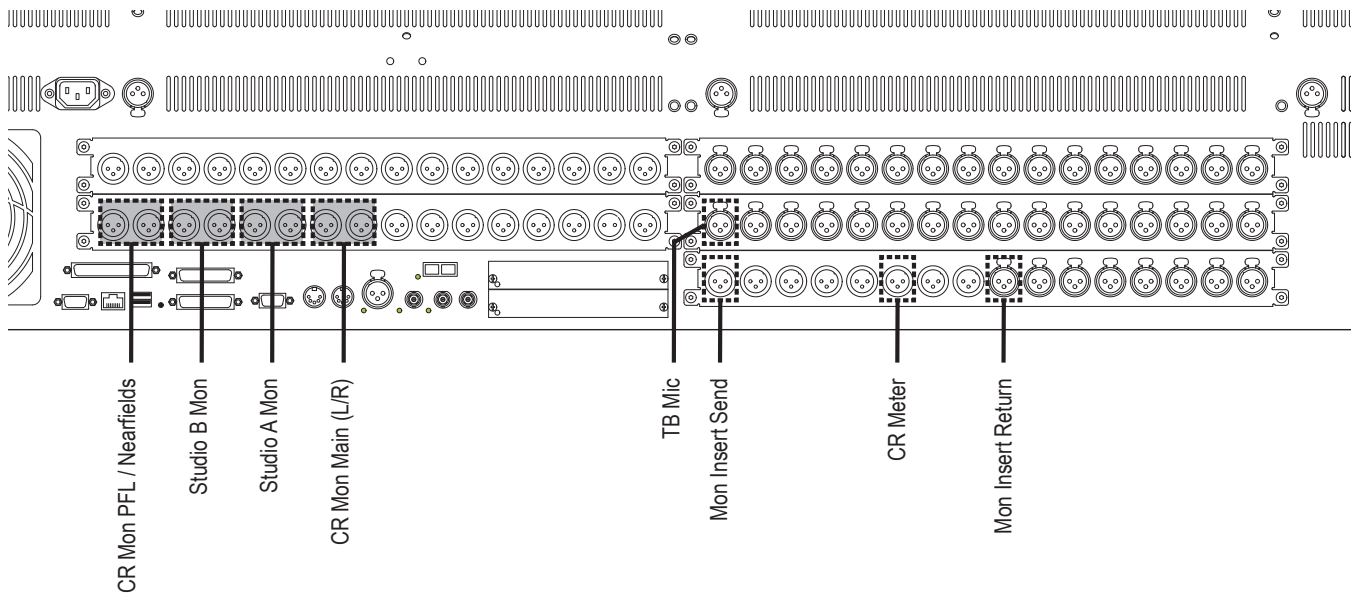

	Format	Analog I/O	Digital I/O	
CR Mon Main	stereo	LineOut 25, 26	-	OUTPUTS
CR Mon PFL/Nearfields	stereo	LineOut 31, 32	-	
CR Meter	stereo	-	AES Out 5/6 (inactive)	
Studio A Mon	stereo	LineOut 27, 28	-	
Studio B Mon	stereo	LineOut 29, 30	-	
Studio A Meter		-	-	
Studio B Meter		-	-	
Mon Insert Send	stereo	-	AES Out 15/16 (inactive)	INPUTS
Mon Insert Return	stereo	-	AES In 15/16 (inactive)	
TB Mic	mono	Mic/Line In 32 (inactive)	-	

Items marked by (inactive) in the table and in white in the drawing above are preconfigured in the mon.ini file; they can be activated by deleting the corresponding comment marks.

6.3.2 'Vista 1 Surround' Configuration Template

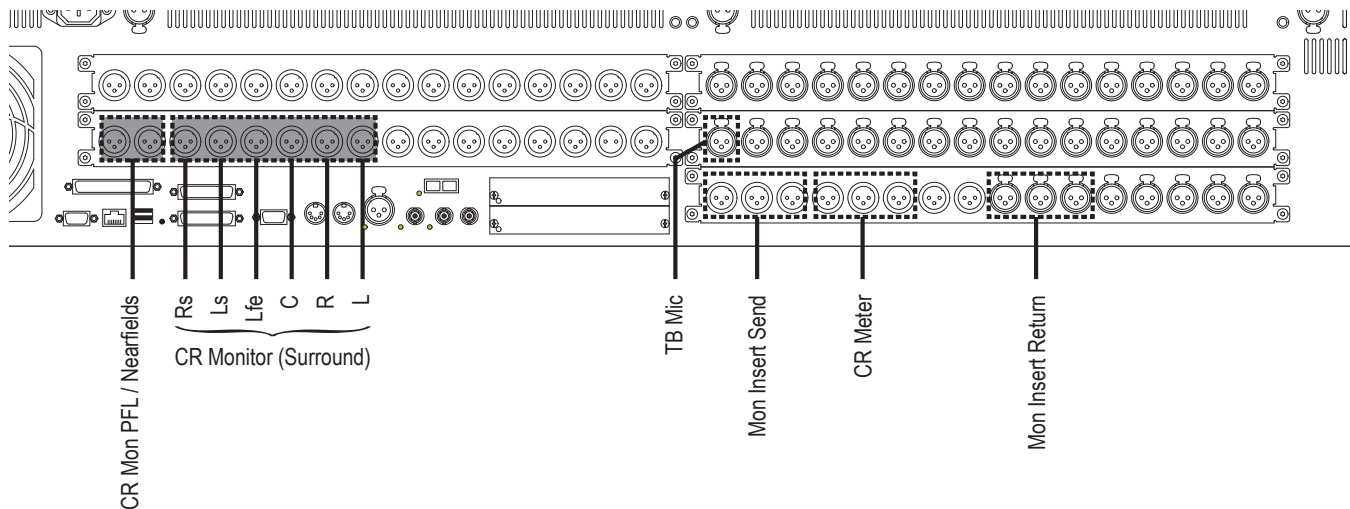

	Format	Analog I/O	Digital I/O	
CR Mon Main	5.1	LineOut 25-30	-	OUTPUTS
CR Mon PFL/Nearfields	stereo	LineOut 31, 32	-	
CR Meter	5.1	-	AES Out 5-10 (inactive)	
Studio A Mon	stereo	-	-	
Studio B Mon	stereo	-	-	
Studio A Meter		-	-	
Studio B Meter		-	-	
Mon Insert Send	5.1	-	AES Out 11-16 (inactive)	INPUTS
Mon Insert Return	5.1	-	AES In 11-16 (inactive)	
TB Mic	mono	Mic/Line In 32 (inactive)	-	

Items marked by *(inactive)* in the table and in white in the drawing above are preconfigured in the `mon.ini` file; they can be activated by deleting the corresponding comment marks.

CHAPTER 7

7	DAW Control.....	3
7.1	Basics.....	3
7.2	Vista Settings.....	5
7.3	DAW Settings.....	8
7.4	Connect the Sessions.....	9
7.5	Channel Strip Control Keys.....	11

7 DAW CONTROL

7.1 Basics

With the Vista consoles it is possible to directly operate Digital Audio Workstations (DAW) from the desk surface and/or the graphical controller (GC) screen. This is realized by using two different serial communication protocols: The straightforward and simpler Mackie Control Protocol, and the more complex Mackie HUI Protocol.

A choice of the most popular DAWs is supported and has been tested with the Vista desk control:

- Digidesign ProTools (Mackie HUI protocol)
- Apple Logic Pro (Mackie control protocol)
- Merging Technologies Pyramix (Mackie HUI protocol; *Mackie control protocol not fully supported*)
- Steinberg Cubase / Steinberg Nuendo (Mackie control protocol; *Mackie HUI protocol: only 8 channels supported*)
- Magix Samplitude / Sequoia (Mackie HUI protocol, Mackie control protocol)
- SADiE (*Mackie HUI protocol: only 8 channels supported; Mackie control protocol: only 24 channels supported*).

DAW channels can be inserted into any desired slot of the strip setup. With a DAW channel a number of DAW commands can be operated, as provided by the Mackie Control protocol: Fader level, mute, solo and track arming.

Transport control keys are optional on the desk of the larger Vista versions only; on any Vista console, however, the transport controls are available in the TC/Generator window; they can also be used for transport commands to the DAW.

The TC/Generator window is opened by a click on the GC toolbar icon shown left.

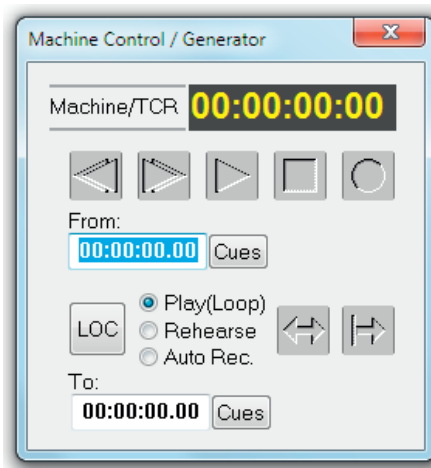
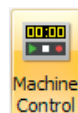

Note *DAW channels are excepted from snapshots and presets, no DAW settings will be saved or can be recalled, apart from the channel strip position defined in the strip setup.*

When controlling the DAW via HUI, an auto-label mechanism copies the channel labels of the workstation project from the DAW channel strip to the Vista console. If the DAW should not support HUI (see list above), user labels can be manually entered in the strip setup now for every DAW channel.



EMPTY	DEL
Input	▶
Group Master	▶
Master	▶
Aux Master	▶
Control Group Master	▶
DAW Control	▶
VMix	▶
Cut	Ctrl+X
Copy	Ctrl+C
Paste	Ctrl+V
Edit User Label	Ctrl+E

Note Only *one* DAW can be controlled at a time. The Mackie protocols support a *maximum of 32 channels*, so this is also the maximum number of DAW channels that can be controlled.

7.2 Vista Settings

Machine Control Window In case the Timecode/Generator/Machine Control icon should not be shown in the GC, proceed as follows:

- Open the C:\D950System\D950system.ini file.
- Under [options], edit the two lines shown in bold print below:

```
[options]
TC2=No
TC3=No
InternalTC=Yes
MeterOverNet=No
DynamicAutomation=No
StaticAutomation=Yes
MidiActive=Yes
TheatreMode=No
```

Transport Control Enable To enable transport control specifically for the connected DAW, there is a menu option in the TC Reader / Generator setup dialog. Please note that the 9-pin serial control is disabled as soon as the DAW Control setting is selected:

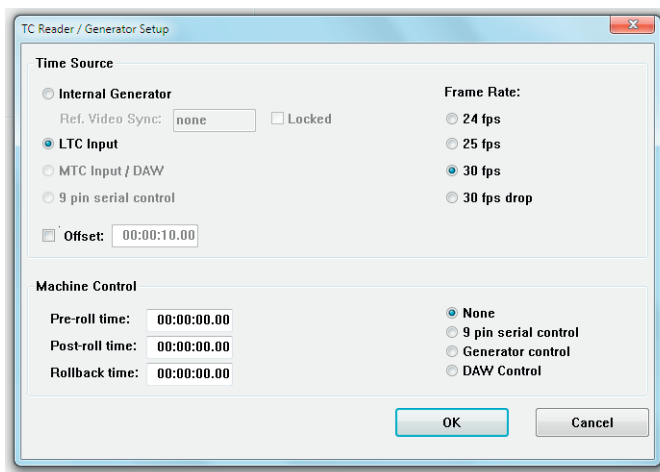

MIDI-Over-Ethernet: Instead of the MIDI connection normally used as the physical layer for the Mackie protocols, a MIDI-over-Ethernet solution is used that allows using one single Ethernet Cat5 cable instead of several MIDI cables. Therefore the 'ipMIDI' driver needs to be installed on both the Vista desk PC and on the DAW.

Protocol Selection Protocol selection (Mackie Control or Mackie HUI) is done in the Vista Settings dialog. This is not done automatically but has to be decided by the user with the help to the information given in [chapter 7.4](#):

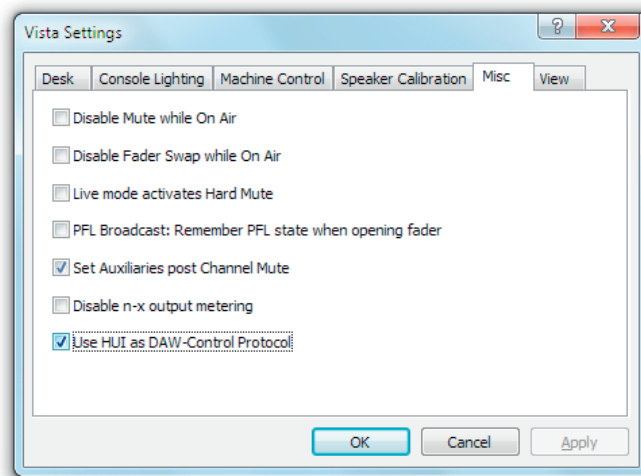

rtpMIDI (rtpMIDI is the current MIDI-over-Ethernet driver, that needs to be installed on the Vista console PC)

- Install rtpMIDI v1.1.4.235 (requires Bonjour V2.0.2.0 or later) - for installation details, please refer to the Vista Installation Note “Vista DAW Control with rtpMIDI”

Setup of rtpMIDI on Vista Run rtpMIDI and create 4 Sessions using the [+]-Button. The sessions will automatically get the name of the computer and will appear in the directory window. Rename the sessions to Vista, Vista (1), Vista (2), Vista(3) as shown below.

Enable the sessions with the checkmark in the order below - start with “Vista”, then “Vista (1)”

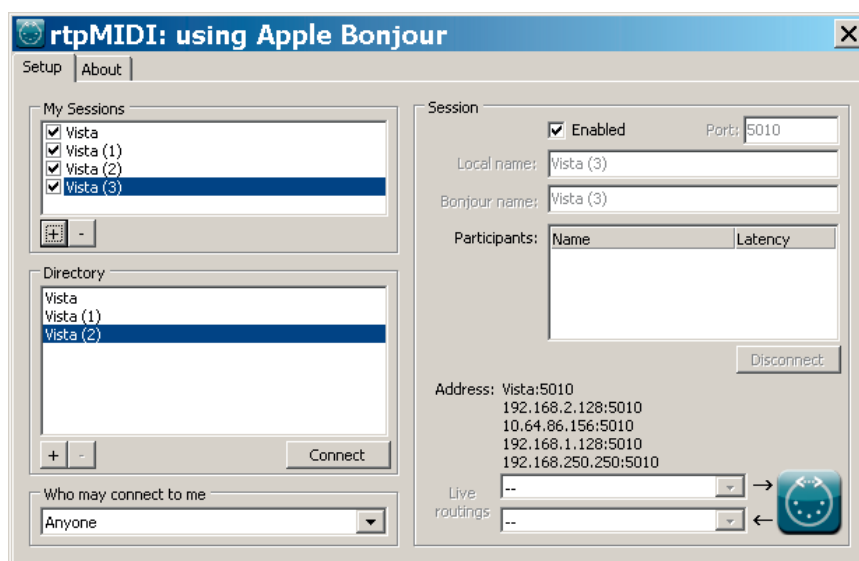

System MIDI Port Make sure that the Windows operating system does not assign one of the above MIDI sessions to the Windows default output device. A channel shift might be the result of this faulty assignment.

Open the Windows Control Panels after the above installation steps, open the Sounds and Audio Devices Panel and select the “Audio” tab.

In the example below, the MIDI playback default device is showing Vista (3), which is one of the rtp sessions. This is a faulty configuration.

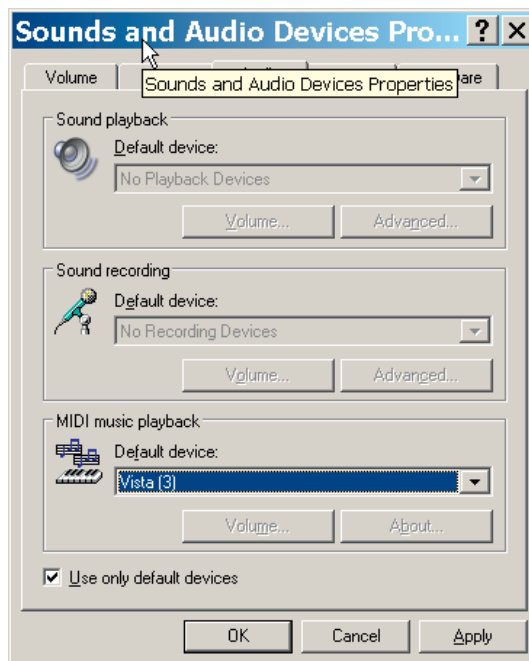

Choose another device if available, depending on the operating system and hardware, there can be a free onboard device. If there is no available alternative device, there are 2 alternatives :

1. choose a 5th session in the rtpMIDI setup and give it a different name, e.g. “SystemDefault”

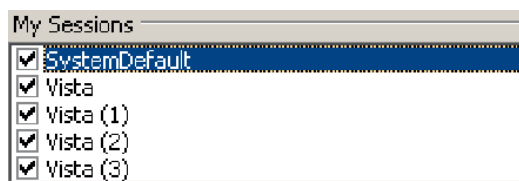

and choose it as default device



2. install a dummy output device, like MIDI Yoke and assign it as default device.

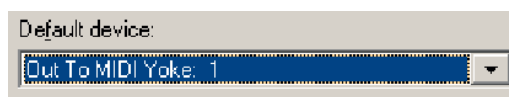

MIDI communication speed

rtpMIDI allows to increase the communication speed. In order to change this parameter proceed as follows :

- Open rtpMIDI, press and hold CTRL, and double-click with the left button into the empty field to the right of the About tab. An advance tab will appear.

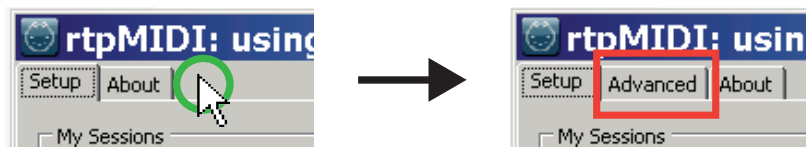

- Open the advanced tab and change the bitrate from the standard 31250 to maximum:

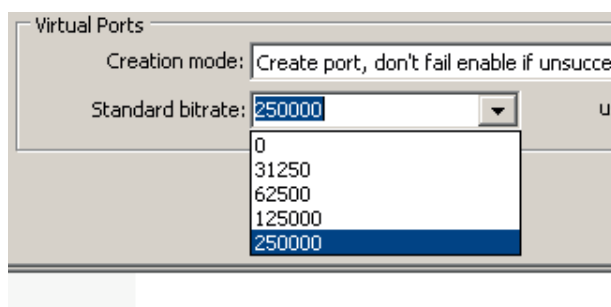

Specify MIDI Ports (i.e., MIDI ports used for DAW Control)

- While using rtpMIDI, add the following two lines into **D950system.ini** as shown below. (*Please note: the entry is case sensitive*).

```
[Midi]
DawPorts="Vista"
```

7.3 DAW Settings

rtpMIDI (to be installed on the DAW system running on Windows platform)

- Install rtpMIDI v1.1.4.235 (requires Bonjour V2.0.2.0 or later) - for installation details, please refer to the Vista Installation Note "Vista DAW Control with rtpMIDI"

Note *Mac workstations running on OS X do already provide the rtpMIDI- functionality.*

7.4 Connect the Sessions

Vista Assign each session in the My Sessions window on the Vista installation to the corresponding one on the DAW computer, which is also listed in the Directory window. In the example below it is :

- Vista to Mac DAW
- Vista (1) to Mac DAW (1)
- Vista (2) to Mac DAW (2)
- Vista (3) to Mac DAW (3)

Select the corresponding sessions in My Sessions and Directory and press “Connect”

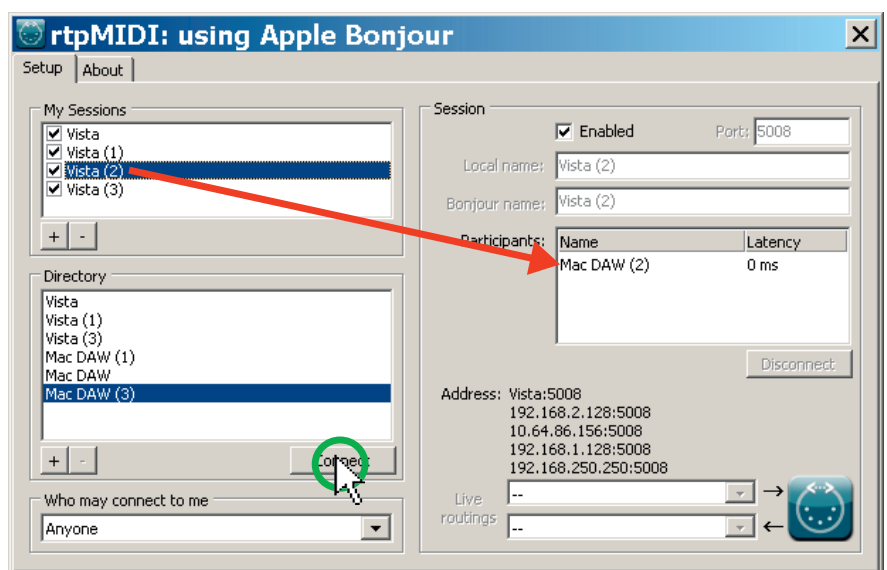

DAW In ProTools, set the according session in Peripherals - MIDI Controllers menu

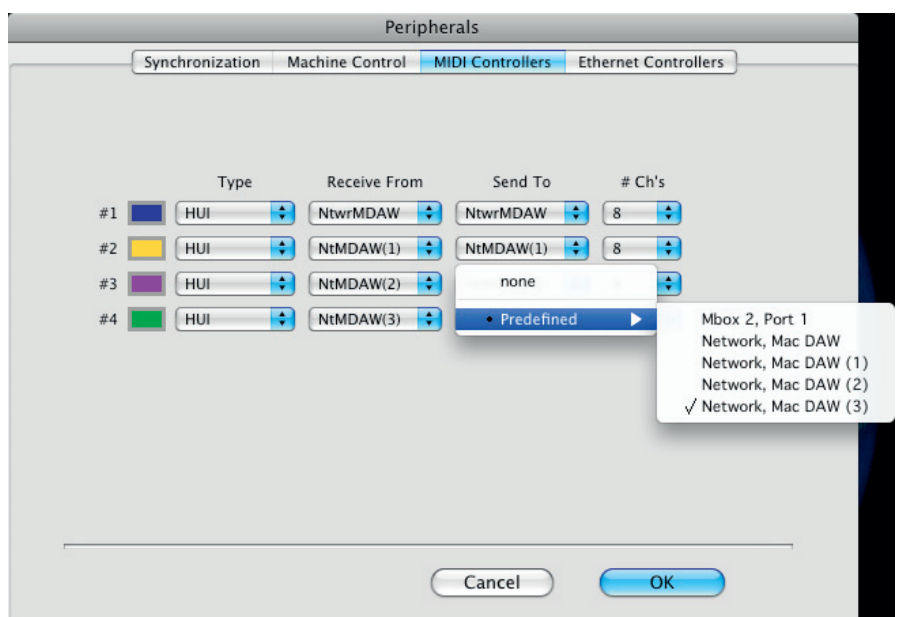

Please note : if Created Sessions do not show up in ProTools Dialog, make sure all Input Devices are activated as shown below :

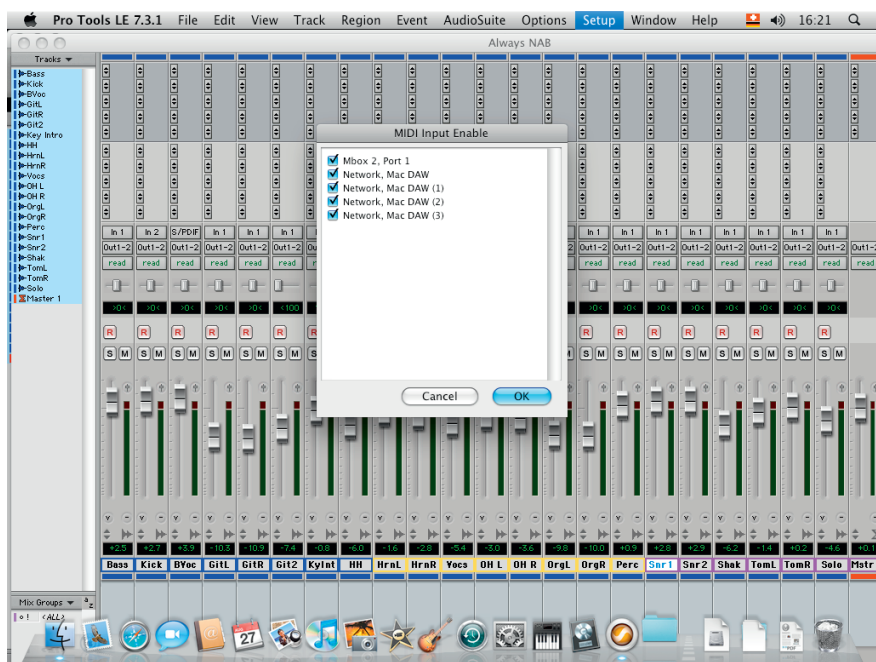
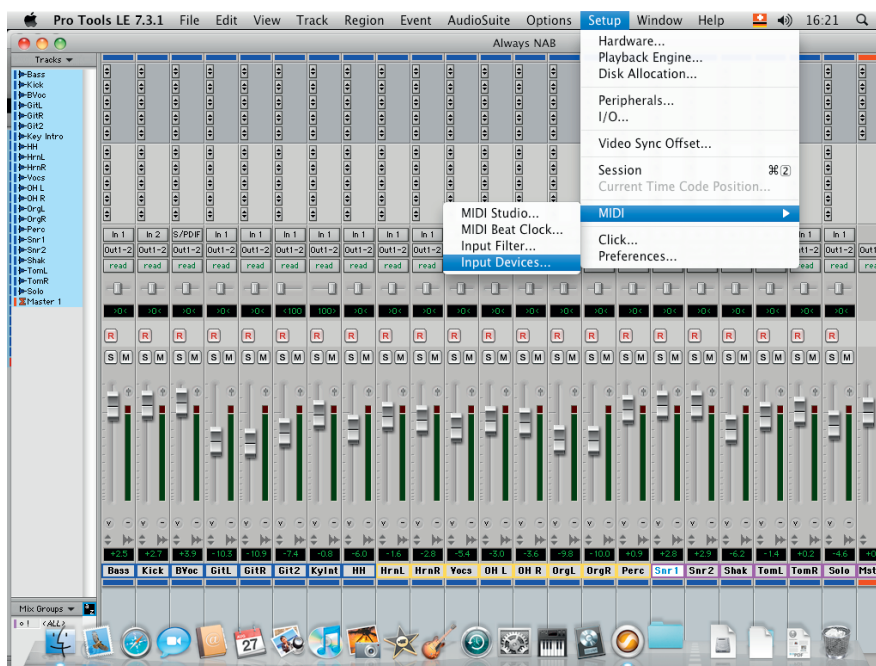

7.5 Channel Strip Control Keys

The desk keys marked below can be used for DAW channel control:

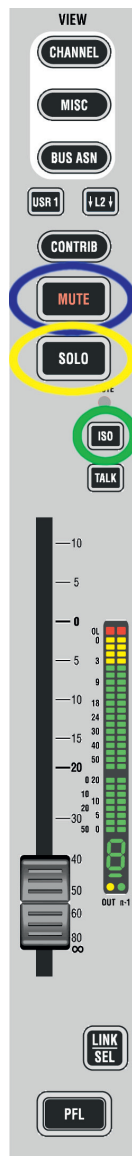

The marked keys can be used to control the following DAW functions:



- Mute
- Solo
- Track Arming

CHAPTER 8

8 RELINK (Resource Linking).....3

8.1 Input Patching.....3

8.2 Output Patching.....4

8.3 Microphone Take-Over Procedure.....6

8.4 Vista Restrictions.....9

8.5 Technical Details.....10

8.5.1 Vista I/O Sharing Setup.....10

8.5.2 Restricting Shared I/O.....14

8.5.3 Configuration Changes.....14

8.5.4 Container.ini.....15

8.5.5 D950System.ini.....17

8.5.6 Tie Line Management.....17

8.5.7 Control Network.....18

8.5.7.1 Vista 1, 6, 7, 8.....18

8.5.8 IP Addresses.....18

8.5.9 Audio Sync for all Systems.....19

8.6 Messages from Other Systems.....19

8.7 Labels from Other Systems.....19

8.8 Locked Patch Points.....20

8.9 Stereo and Surround Sources.....20

8 RELINK (RESOURCE LINKING)



Studer RELINK is an I/O sharing network technology available for all Studer products (OnAir and Vista consoles, Route 6000) allowing direct access to sources and targets throughout the entire network – provided that the desired sources and targets are configured as ‘NetSources’ and therefore available for remote components of the system.

RELINK allows the design of ‘distributed’ audio network systems: enabling Studer products to access all sources and targets of the complete system, and therefore enhancing the flexibility of your facility.

Microphone control ‘take-over’ mechanisms are implemented on both the OnAir and the Vista consoles.

On the OnAir consoles, signaling is coupled with the I/O sharing, which means that red light, fader start and signaling connections automatically follow any console where the audio signal is used, and are correctly applied to the source (Studio, CD Player, etc) from anywhere.

On the Vista side, RELINK is a software functionality that is independent from the hardware, allowing systems still using a Performa DSP core being part of the network, too, as long as all the mic preamplifiers are of the D21m type.

RELINK requires the following SW versions (or newer ones): Vista SW V4.1, OnAir SW V3.1, and Route 6000 SW V2.0.

8.1 Input Patching

With SW V5.2, a new source and target navigator menu has been introduced. It still is a pull-down menu, but it shows not only local sources and targets, but also sources and targets of all systems connected via the network. To see the connected systems, the marked button has to be clicked. All connected systems are then listed and their ‘NetSources’ are shown.

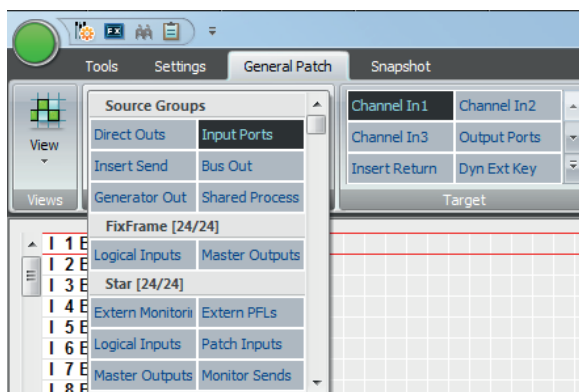
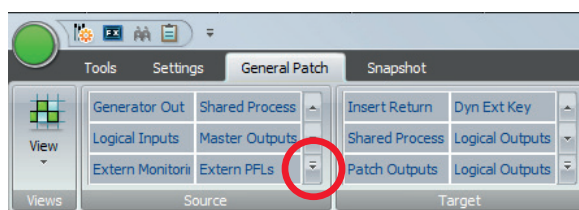

Shared inputs can be selected directly from any of the displayed systems. The sources of OnAir consoles – e.g. a DJ microphone – are appearing as ‘Logical Inputs’, and their output signals as ‘Master Outputs’. Please note that the names of the connected systems are only shown when the whole tab is unfolded. Right after the name of the system, two numbers are displayed which inform about the amount of connections to this system.

FixFrame [24/24]

The first number is the amount of *still available* mono audio channels coming from this system. The second number is the amount of *configured* mono audio channels coming from this system.

8.2 Output Patching

To get to the outputs of the connected RELINK-systems, the targets-tab has to be unfolded, so that the system names are displayed. Here, also the number of still available audio channels - and the number of totally configured audio channels to this system are listed.

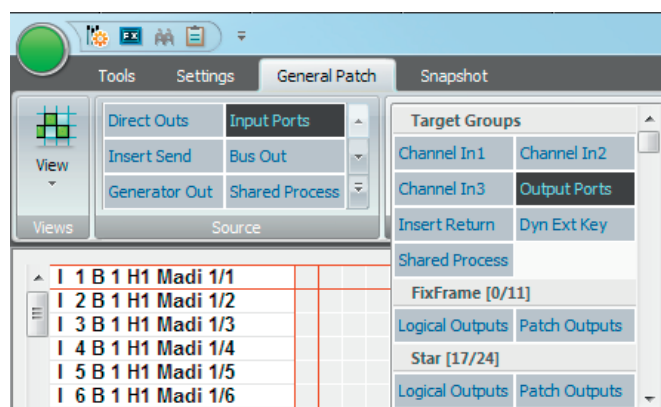

‘Set Outputs’ activates all preselected patch points to outputs on remote systems. This introduces an additional safety step in creating a remote patch connection.

The operator might want to switch several outputs to a different system (e.g. program outputs) at the same time. So when he is making the connections in the patch, they are marked in gray, indicating that the connection has not yet been established. Only when the ‘Set Outputs’ button is clicked, all the gray connections are set active at the same time. ‘Set Outputs’ only becomes active if some output patch connections are made to other systems.

This is only necessary when doing patch connections manually. When using snapshots, the connections are applied immediately.

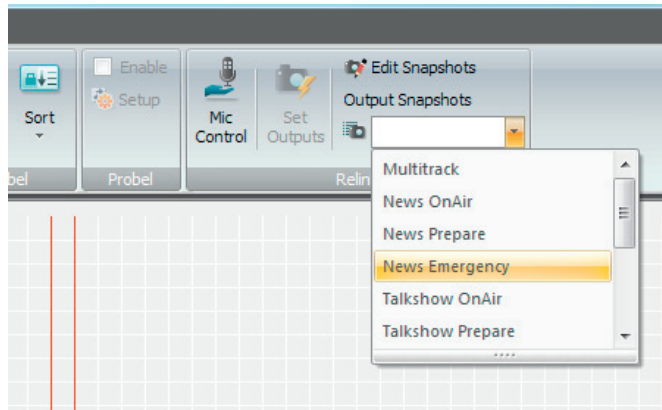

There is now also a new Edit dialog that allows saving multiple output patches to shared targets as 'Output Snapshots'. They must be given a name so that they can be recalled later from the lower right corner of the GC (Graphical Controller). An existing 'Output Snapshot' can be loaded as well, which means that the saved patch connections are not established but just shown in the gray, 'pending' state instead. In this state, the pending connections can now be edited and saved, e.g. under a new name.

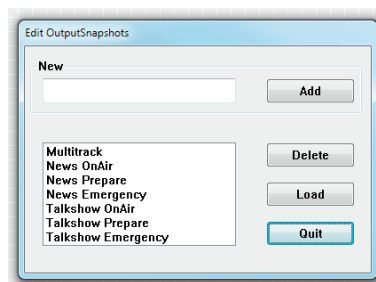

8.3 Microphone Take-Over Procedure

The following status diagram shows how the mic control take-over mechanism is realized in the OnAir3000. This has to be followed, since it is firmly implemented in the DNet code.

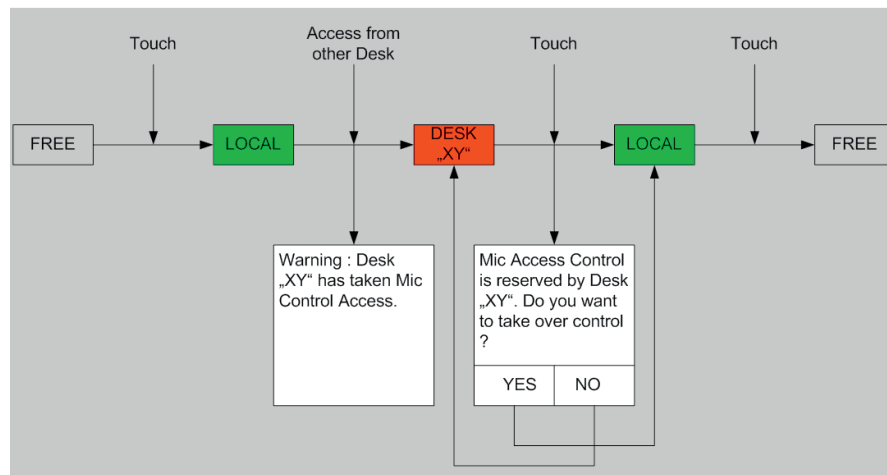

With the Vista desk, this dialog is handled in the channels Vistonics view. This means that also a number of channels can be linked (making a 'gang') and all can be taken over at the same time.

There is one difference from the OnAir behavior: When a mic source of another system is patched to a local input channel as long as the mic control is not already taken by another desk (i.e., 'free' in the OnAir terminology), control is automatically given to the local Vista and the mic control parameters are displayed immediately.

There is an additional **MIC CTRL** parameter in the Viconics view that allows setting the mic access control to **Free**, so that the mic can be controlled by other systems directly.

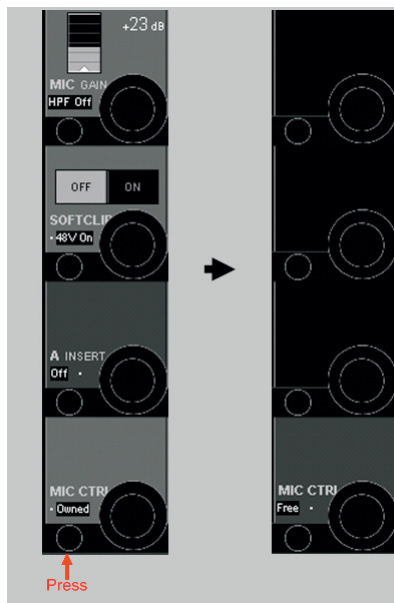

A description of how the different states look like is given below.

- 1a First, no microphone is connected to the channel. Then, a shared mic currently in use by another OnAir or Vista console is manually patched to the input channel:

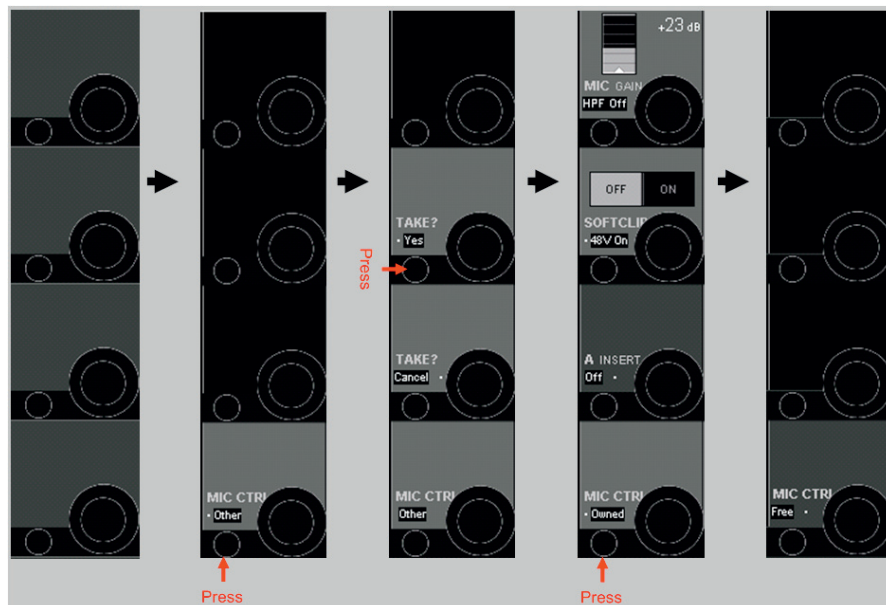

- 1b First, no microphone is connected to the channel. Then, a shared mic currently *not* in use by another OnAir or Vista console is manually patched to the input channel:

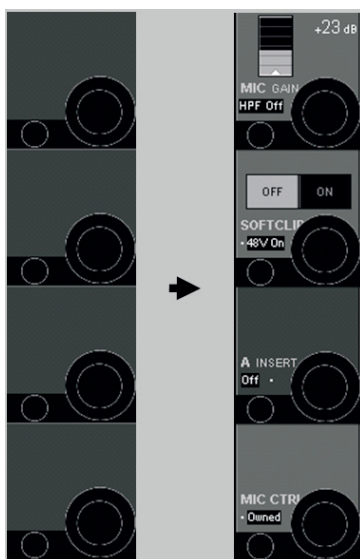

The same behavior is valid if one or more shared mics currently *not* in use by other systems is/are patched to the local input channel via a snapshot.

- 1c If one or several shared mics are used on other systems but then get patched to a local channel via a snapshot, the following message appears on the GC:

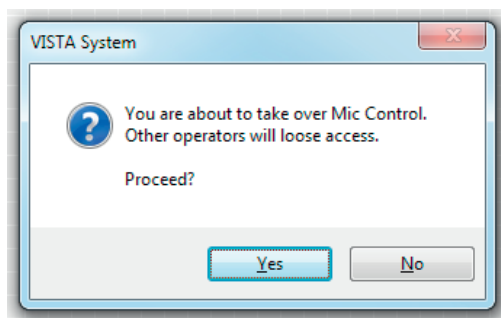

If confirmed with yes, the control for all the shared mics patched in the snapshot is taken over from the other systems.

- 2 A shared microphone is patched to an input channel but then is taken over from a different desk:

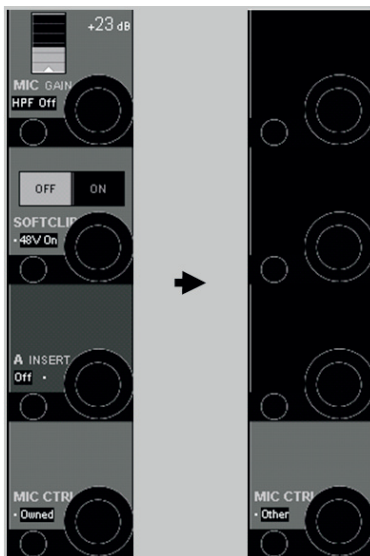

If this happens (on a single channel, or also on several channels at the same time), a warning message appears on the GC screen:

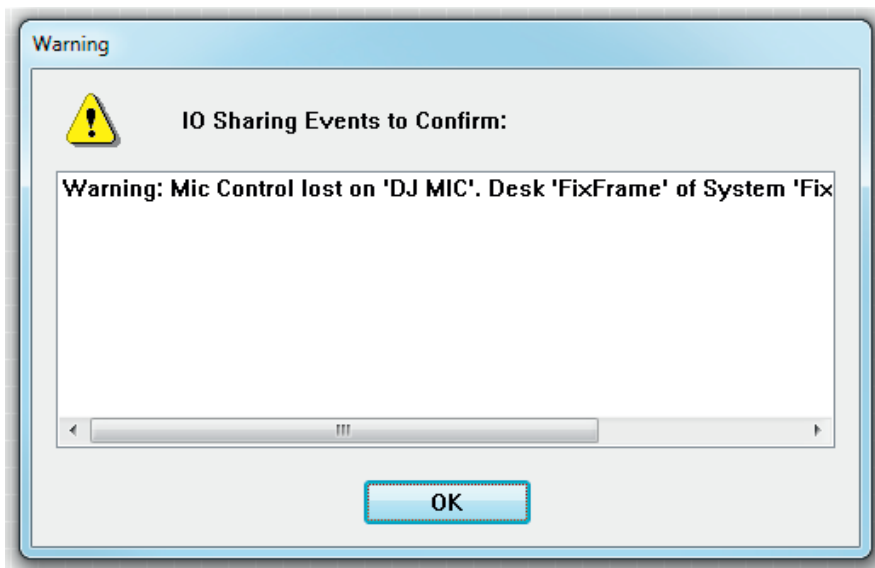

This is the warning window that shows all I/O Sharing events. It disappears after confirmation with **OK**.

8.4 Vista Restrictions

- Signaling, such as red light or fader start, is *not* combined with I/O Sharing.
- Vista systems cannot have any 'NETInputs' configured.
- 96 kHz sampling rate configurations on Vistas can only be used when *no OnAir console and no Router* is involved in the RELINK network. As long as only Vista systems are within the RELINK network, 96 kHz configurations can be used. However, *all Vistas* then need to run at 96 kHz.

8.5 Technical Details

8.5.1 Vista I/O Sharing Setup

ConfigTool for DNet Applications For configuring the tie lines necessary for I/O Sharing on a Vista system, we use the ConfigTool for DNet Applications known from the OnAir product range. This program now needs to be installed on the Vista control computer (C:\Release ConfigTool\ConfigTool.exe). In the same folder there needs to be a file named container.ini with setup information for this DNet ConfigTool. Here is an example of a DNet ConfigTool container.ini file:

```
#####
#
# container.ini: Necessary for initialization of each container (.exe)
#
# Digital Mixing Console: VISTA
# Studer Professional Audio GmbH, Regensdorf, Switzerland
#
# Last modification      : Sep, 1st 2006
# Compatible with OATreeLib : V2.1
# Author                : SIA
#
# Rules:
# =====
# - always leave one blank before and after the (<=>) (e.g. systemid=1 NO!)
# - never change the left expression
# - the right expression of systemid, containerid, systemname
#   and containername MUST be defined
#
#####
```

```
# The systemid identifies the mixing console system to which this container
# belongs to. The systemid is a unique number within a network.
# The serial number must be in the range 1...255
```

```
systemid = 36 ← this must be a unique number
```

```
# The systemname identifies the mixing console system in a readable way
# and must be unique within a company resp. network. It is recommended
# not to use more than 8 characters due to visualization aspects.
# «Undefined» is not allowed!
```

```
systemname = «ConfigTool» ← the name of the system
```

```
# The containerid identifies this container
# and must be unique within the mixing console system
# This id is fixed to <10> (CORE) for all VISTA desks
```

```
containerid = 20 ← ,20' is always used when the container.ini belongs to a configuration tool
```

```
# The containername identifies this container in a readable way
# and must be unique within the mixing console system. It is recommended
# not to use more than 8 characters due to visualization aspects.
# «Undefined» is not allowed!
```

```
containername = «Config» ← the name of the container
```

```
# Multicast
```

```
# -----
```

```
# If you use IGMP multicasts instead of broadcasts in your network,
# you have to uncomment the lines below. It is possible that a
# container is member of one or more than one multicast groups.
```

```
#
```

```
# NOTE: For an optimal performance, make sure that all network resources
# (Switches, Routers...) support IGMP.
```

```
#
```

```
# NOTE: To avoid IP conflicts, check the available addresses for
# multicast groups (www.iana.org). Use preferable addresses from the
# local scope (239.255.0.0/16) described in RFC 2365.
```

```
#
```

```
# NOTE: If the multicast should reach computers beyond the local subnet
# Set MulticastTimeToLive > 1 (1 is default)
```

```
# MulticastGroup = 239.255.0.1
```

```
# MulticastGroup = 239.255.0.2
```

```
# MulticastGroup = 239.255.0.3
```

```
# MulticastTimeToLive = 10
```

```
# Multiple Network Adapters
```

```
# -----
```

```
# When more than one network adapter is enabled on the computer, the MAC Address has to be specified
```

```
#
```

```
# MAC = 00-1A-A0-B9-F9-88
```

Note: With the exception of Vista 1, there needs to be a second **container.ini** file on the Vista's control computer – the one that belongs to the mixing console application.

Start 'Config tool for DNet applications' in the Vista console's C: drive
(C:\Release ConfigTool\ConfigTool.exe)



Select one of the DNet systems available in the network and the appropriate Vista system.

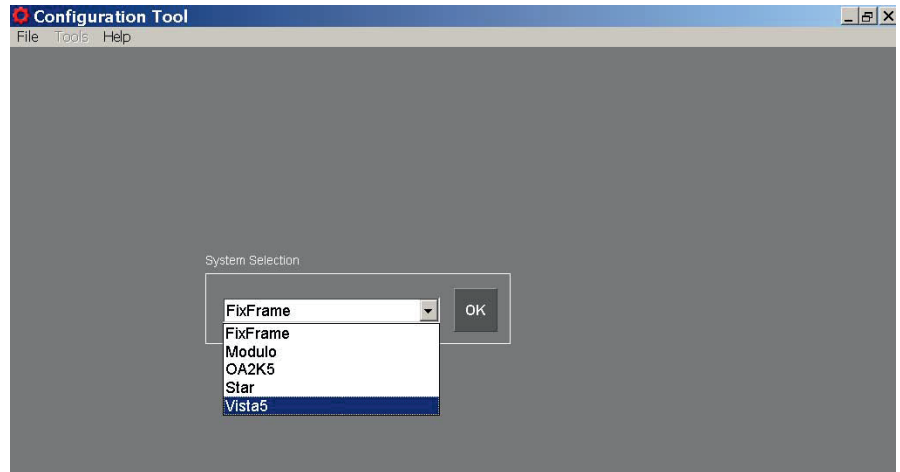

If the Vista or the other connected systems do not appear verify the settings in the **Container.ini** file.

In the configuration tool, go to **Physical Connections**. Under **Destination** all HD links within your system are listed.

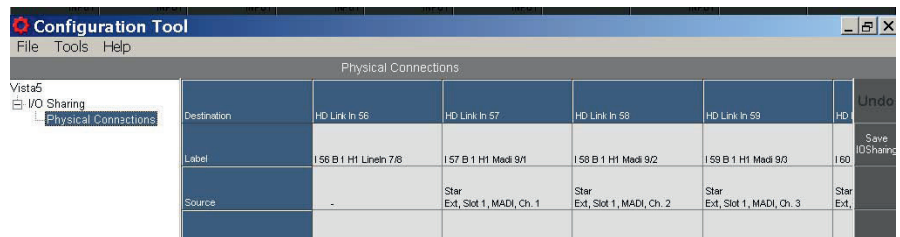

Select the *physical inputs* to be used as tie lines. Once they are configured as tie lines, they will no more be visible in the Vista general patch. *Configuration always takes place on the consuming (or target) system.* Only the tie line inputs need to be configured, i.e., the tie lines that are directed *towards* the target system. The tie lines that go *away from* this system are configured as inputs on the other systems, such as the router.

Select the appropriate *system* (e.g. 'Star router', as shown below):

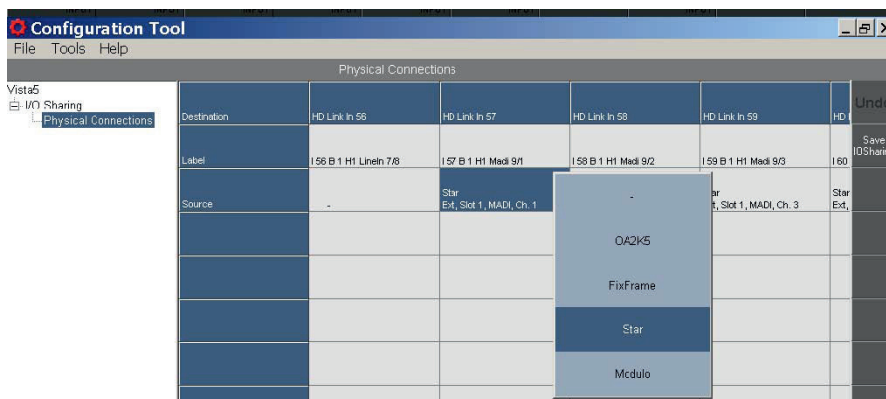

In the next step a *D21m frame* is selected (the external frame Ext in our example):

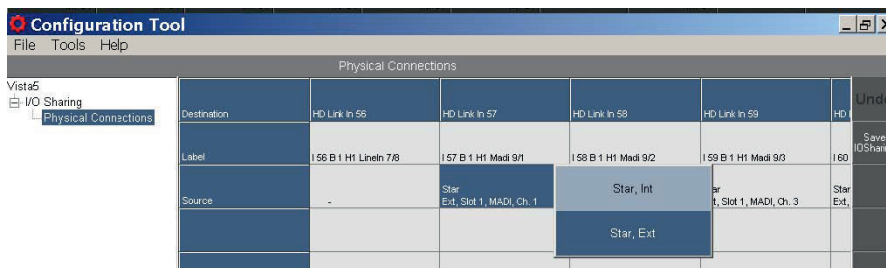

Now select the appropriate *interfaces* (e.g. MADI), one by one, for every single physical audio connection.

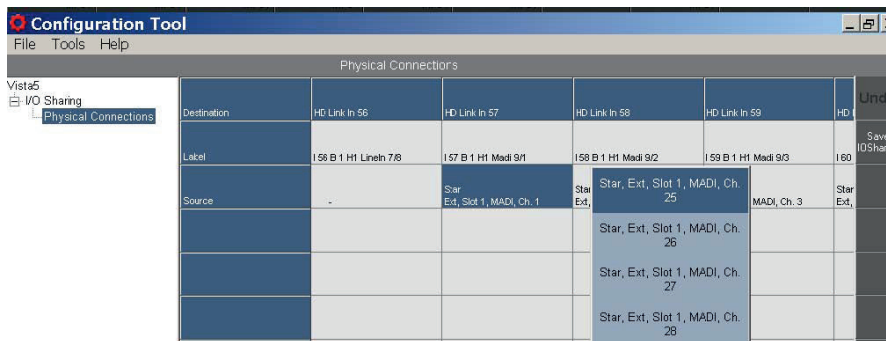

When finished, click the Save IO Sharing button at the right-hand edge of the Configuration Tool GUI.

This procedure only needs to be done once during system setup. All these tie line configuration settings are saved on the consumer side and will remain after a system restart.

8.5.2 Restricting Shared I/O

Per default, all sources and targets attached to a Vista system can be seen and used by other systems that are part of the I/O Sharing network. Access to these I/Os may be restricted; they can then be used on the local Vista system only, but are not available to other systems within the network.

This is done with a text file containing a list of fixed labels of the I/Os *that should be visible to others*; the file must be named **SharedPatches.iosharing** and saved in the folder of the VMC configuration which it is valid for, such as **D950SystemDB\Config1**.

SharedPatches.iosharing Example:

```
...  
I 17 B 1 Ch17  
I 18 B 1 Ch18  
I 19 B 1 Ch19  
I 20 B 1 Ch20  
I 21 B 1 Ch21  
I 22 B 1 Ch22  
I 23 B 1 Ch23  
I 24 B 1 Ch24  
...
```

Notes: The I/O configured as tie lines must also be added in this file. If no file with this name is found in a configuration folder, all I/Os of this Vista system will be available for networked access.

8.5.3 Configuration Changes

Every VMC configuration change in a Vista console has an effect on the other consoles using this Vista's I/O at the same time. This means that an I/O can disappear and then reappear in a different constellation.

When using a file named **CommonSharedPatches.iosharing** located in the **D950SystemDB** folder, a number of sources and targets can be defined as I/O *that must not change*. This is useful for inputs or outputs that remain the same throughout all VMC configurations on the Vista. It contains a list of the fixed labels of the desired I/O.

CommonSharedPatches.iosharing Example:

```
...  
I 65 B 1 Ch65  
I 66 B 1 Ch66  
I 67 B 1 Ch67  
I 68 B 1 Ch68  
I 69 B 1 Ch69  
I 70 B 1 Ch70  
I 71 B 1 Ch71  
I 72 B 1 Ch72  
...
```

This file needs to be created manually. If no file with this name is found in a configuration folder, all I/O will be reinitialized by a configuration change.

8.5.4 Container.ini

The container.ini file for the Vista system is found in **C:\D950System**. This file contains some important entries making the I/O Sharing work. Here a list of these entries:

```
#####
#
# container.ini: Necessary for initialization of each container (.exe)
#
# Digital Mixing Console: VISTA
# Studer Professional Audio GmbH, Regensdorf, Switzerland
#
# Last modification      : Sep, 1st 2006
# Compatible with OATreeLib : V2.1
# Author                 : SIA
#
# Rules:
# =====
# - always leave one blank before and after the '=' (e.g. systemid=1 NO!)
# - never change the left expression
# - the right expression of systemid, containerid, systemname
#   and containername MUST be defined
#
#####
```

```
# The systemid identifies the mixing console system to which this container
# belongs to. The systemid is a unique number within a network.
# The serial number must be in the range 1...255
```

systemid = 35 ← *this must be a unique number*

```
# The systemname identifies the mixing console system in a readable way
# and must be unique within a company resp. network. It is recommended
# not to use more than 8 characters due to visualization aspects.
# «Undefined» is not allowed!
```

systemname = «Vista9» ← *the name of the system*

```
# The containerid identifies this container
# and must be unique within the mixing console system
# This id is fixed to <10> (CORE) for all VISTA desks
```

containerid = 10 ← *,10' is always used when the container.ini belongs to a Vista desk*

```
# The containername identifies this container in a readable way
# and must be unique within the mixing console system. It is recommended
# not to use more than 8 characters due to visualization aspects.
# «Undefined» is not allowed!
```

containername = «Desk» ← *the name of the container*

Multicast

If you use IGMP multicasts instead of broadcasts in your network,
you have to uncomment the lines below. It is possible that a
container is member of one or more than one multicast groups.

NOTE: For an optimal performance, make sure that all network resources
(Switches, Routers...) support IGMP.

NOTE: To avoid IP conflicts, check the available addresses for
multicast groups (www.iana.org). Use preferable addresses from the
local scope (239.255.0.0/16) described in RFC 2365.

NOTE: If the multicast should reach computers beyond the local subnet
Set MulticastTimeToLive > 1 (1 is default)

MulticastGroup = 239.255.0.1 ← *Multicast groups should all be disabled*

MulticastGroup = 239.255.0.2

MulticastGroup = 239.255.0.3

MulticastTimeToLive = 10

Multiple Network Adapters

When more than one network adapter is enabled on the computer, the MAC Address has to be specified

#

MAC = 00-AA-11-BB-22-CC ← *in case of a Vista 6/7/8 with multiple network adapters, they need to be specified here*

8.5.5 D950System.ini

The following entry needs to be added in the **D950system.ini** file:
IsRelinkActive=Yes

8.5.6 Tie Line Management

On every Vista console, tie lines need to be configured with the OnAir configuration tool. They may be any type of I/O, the most efficient of them are HD links giving 96 channels in both directions per Cat5 cable pair. Furthermore, MADi interfaces with a maximum channel capacity of 64/64 are quite popular for tie lines. MADi tie lines may also be configured to use less than 64 I/O – any desired number smaller than 64. AES/EBU or Line interfaces can also be used as tie lines if only a small number of audio channels needs to be shared, such as for transmission lines.

Tie line management is dynamic, therefore only the maximum number of audio channels used simultaneously needs to be considered.

FixFrame [24/24]

The number of the currently free tie lines is displayed in the sources/targets area of the general patch in the GC, with the total amount of configured tie lines. This is shown for each connected system.

8.5.9 Audio Sync for all Systems

All systems being part of the network that can exchange audio via tie lines must be properly synchronized. The recommended option to do this is having a Studer D21 MasterSync unit feeding word clock in a star configuration to all the systems involved.

If a single system cannot be synchronized, either AES/EBU cards with SFCs or analog cards have to be used for tie lines.

8.6 Messages from Other Systems

When there are patch connections to other systems in the RELINK network – e.g. when using a mic input of another Vista or OnAir console – or when outputs are patched to a Route 6000 or to another console, the local Vista will receive status messages from these systems.

Vista systems receive and display the following message types from OnAir and Route 6000 systems:

- Power loss on Core and D21m frames
- D21m hardware change
- System shut down

Vista systems send the following message type:

- System shut down

These messages are all displayed in the same type of window that also shows mic control messages:

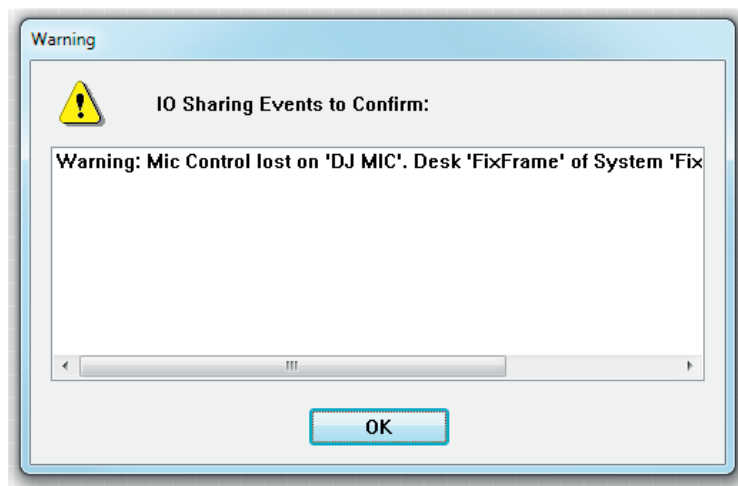

As long as no sources or targets of a remote system are used locally, no status messages of these systems are shown on the local Vista.

8.7 Labels from Other Systems

When patching remote inputs to a Vista system, the 'user label' of this input on the remote system is propagated to the Vista's input channel label display.

8.8 Locked Patch Points

Locked patch points are treated in the same way as local sources.

8.9 Stereo and Surround Sources

The following remote sources can also be in stereo or 5.1 surround formats:

- Vista Direct Outputs (Input, Group and Master channels)
- Stereo and Surround Inputs from OnAir consoles.

These sources can be patched directly, with one single patch point connection, to a local target.

CHAPTER 9

9	Vista FX	3
9.1	Introduction	3
9.2	Effect routing	3
9.3	Operation	4
9.3.1	Engine setup	4
9.3.2	General Patch	7
9.3.3	Create Send Return Effects	9
9.3.4	Create Insert Effects	10
9.3.5	Loading Effects	12
9.3.6	Effect parameters	14
9.3.6.1	Reverbs.....	14
9.3.6.2	Delays.....	16
9.3.6.3	Misc.....	17
9.3.6.4	Dynamics	18
9.3.6.5	Tap Control.....	19
9.3.7	Copy/Paste.....	19
9.3.8	Snapshot operation.....	20
9.3.8.1	Snapshots and Presets	20
9.3.8.2	Static Automation.....	20
9.3.9	Dynamic automation	22
9.3.10	Offline operation	22
9.4	Preset Overview.....	23

9 VISTA FX

9.1 Introduction

Legendary Lexicon® Reverbs and Effects

Software V5.1 allows to have two powerful LEXICON® effects processing engines deeply integrated into the Vista 1 mixing system.

Effect processing engines are useful for any mixing application, but most importantly for sound reinforcement and live broadcast productions. In general, multi-effect units provide effects processing for the most commonly used time based effects, such as : Reverb, Chorus/Flange and Delay. Each effect processing engine supports up to 30 different professional LEXICON® effects, controlled from the intuitive Vistonics interface of the Vista 1 console. The processing is carried out in the Vista 1 FX DSP units which are an integral part of every Vista 1. This hardware is based on the legendary Lexicon DSP-platform, and therefore provide Lexicon effect type categories such as :

- Reverb
- Delay
- Chorus
- Flanger
- Phaser
- Tremolo
- Vibrato
- Rotary
- Pitch Shift
- Detune
- De-Esser

9.2 Effect routing

As with most effect processors, the processing engine can be set-up for mono, stereo and surround effect processing (surround is for reverb effects only).

In the Vista 1, there are two engines available, called “Engine A” and “Engine B”. One engine can get one of the following configurations :

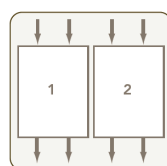

Dual Stereo

- **Dual Stereo**

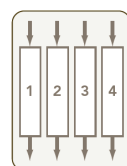

Quad Mono

- **Quad Mono**

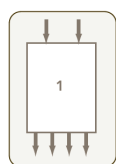

Two In/Four Out

- **Single Two In Four Out**

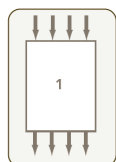

Four In/Four Out

- **Single Four In Four Out**

Once the structures of the effects engines are defined, their inputs as well as outputs are available in the general patch of the Vista 1 consoles GC.

To make working with Vista FX as easy and straightforward as possible, Vista FX are intended to be used in two ways :

Send-Return Effects

This is the effect structure that has been used in the analog world with traditional outboard effects - using an Aux bus to add signal from several channels, and then feed it from the Aux to one single effect unit. To get the 'wet' effect signal back into the mix, an input channel ("effect-return") has to be used.

Since this is still a practical way of working, and because many operators are very familiar with this concept, it is also used for Vista FX.

Insert Effects

When an effect is only used for one single channel, it can be patched into the channels insert path. The effect then cannot be used for any other channels.

These two effect concepts can be used with Vista FX, and are explained in more details in the following chapter.

9.3 Operation

9.3.1 Engine setup

As the starting point for working on a session by session basis with Vista FX, the engine setup needs to be carried out.

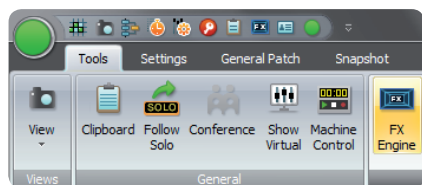

By pressing the **FX** button, the Vista FX Engine Setup window opens up.

The Vista FX Engine Setup window has one tab : **DNA1**

Two engines are shown : **Engine A** and **Engine B**.

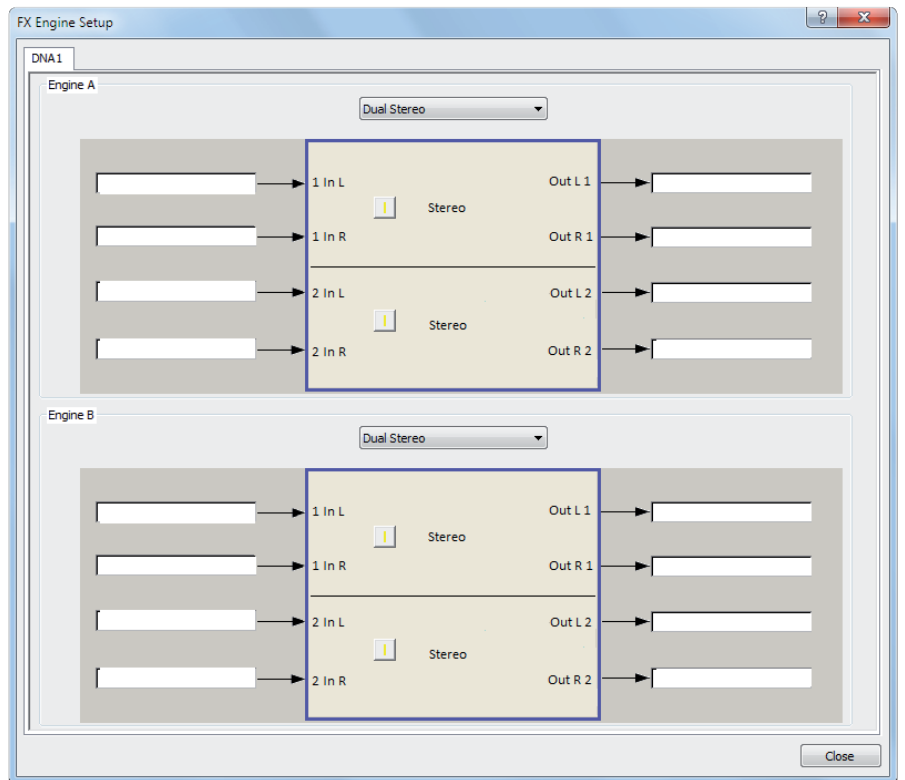

As a standard, always two 'Dual Stereo' configurations are loaded.

Clicking on the pull-down menu, the choice of engine setups is presented, and one can be chosen to be applied into the desired engine.

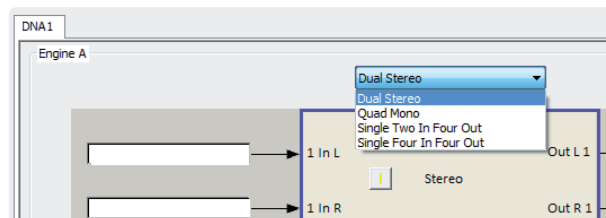

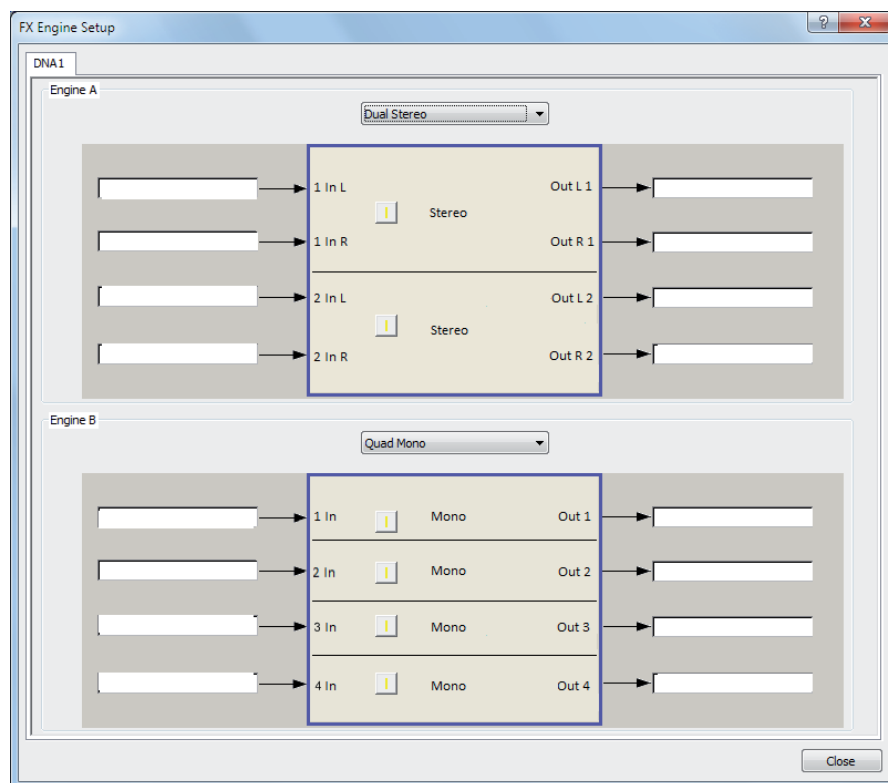

Dual Stereo setup : This setup provides two stereo effect machines for one engine. It is suitable for usage of a stereo effect, e.g. a stereo reverb. Since two machines are available, the user has the benefit of running two different stereo effects at the same time. The stereo effect then can be used as a send-return effect, or also as an insert effect for a stereo channel.

Quad Mono setup : This provides four mono effect machines for one engine. It is the preferred choice when using insert effects for mono channels. With both engines in this setup, up to eight insert effects can be provided. Of course, also the combination of different setups per engine is possible (see screenshot above).

Single Two In Four Out setup : This setup can be used to create a four channel surround effect with a simple stereo signal as the source. A nice way to create surround ambiance for a stereo track.

Single Four In Four Out setup : This setup allows to create real surround effects. A 4.0 surround input signal (L,R,Ls,Rs) will create a 4.0 effect signal.

When the setup procedure has been done for the two engines, the necessary input- and output ports are ready to be used in the general patch page.

Note : The engine setup is the base setup on which all later selected effects are loaded. So changing the engine setup after effects have already been worked with, will reset all effects and they will need to be reloaded again! There is a warning window which informs about the consequences that the changing of the engine setup will have :

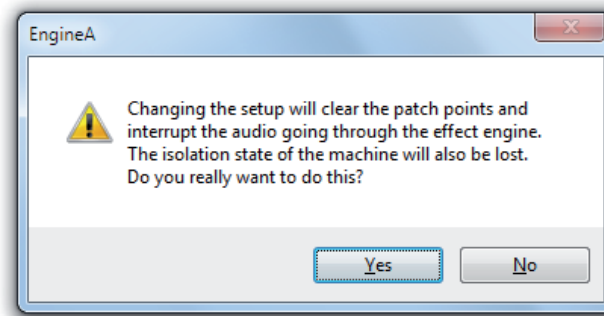

Note : Also the state of the engine setup is stored in snapshots. This means that the engine setup can be changed by recalling a previously created snapshot.

9.3.2 General Patch

On the General Patch Ribbon Tab (**General Patch**), there are additional sources and target categories where the effect input- and output ports can be found.

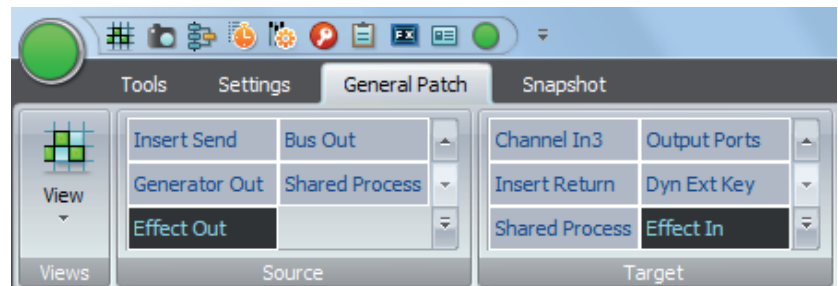

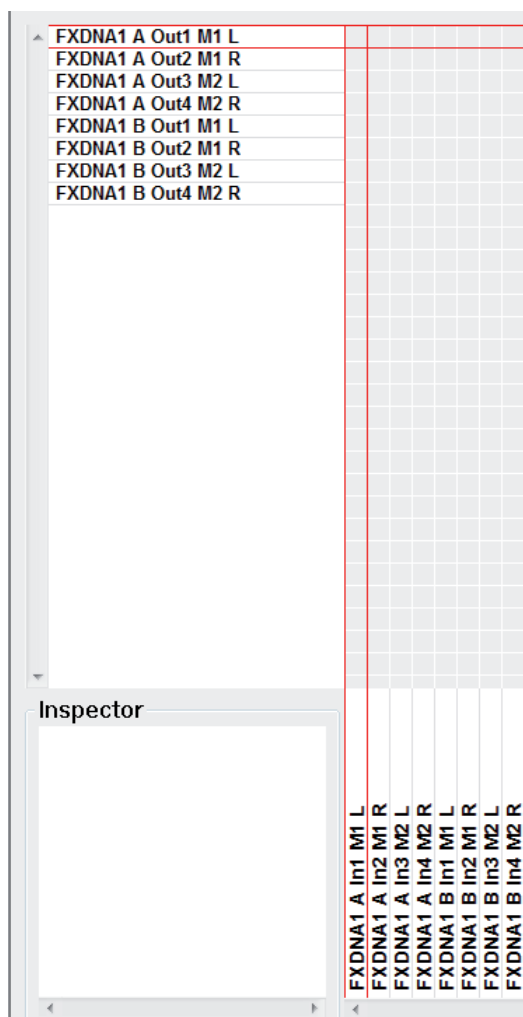

The general patch always shows four input- as well as four output ports per engine. Because two engines are provided, the total of shown patch points is always eight input- and eight output ports.

Patch connections now can be made as with other sources and targets. Once connections are made, they will also be indicated in the FX Engine Setup window :

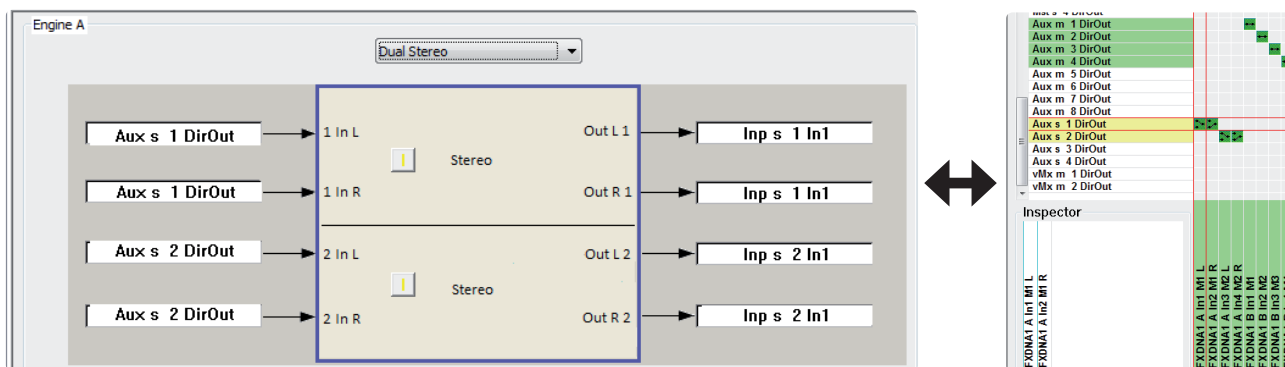

As a shortcut for ‘patching to effect targets’ and ‘from effect sources’, it is also possible to doubleclick into one of the eight label areas in the setup window. This then navigates directly to the general patch, to the desired target or source.

9.3.3 Create Send Return Effects

To setup the desk for working with a ‘Send-Return’ effect, a few steps of preparation need to be carried out :

1. Patch the Direct Out of the desired Aux master to the effect input port.

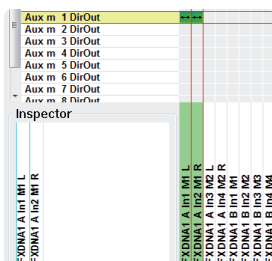

This will change the colour of the Aux send icons, as well as the Aux master to blue. This is to indicate that the chosen Aux bus is used as an effect send.



2. Patch the effect out port to the desired return channel (input channel).

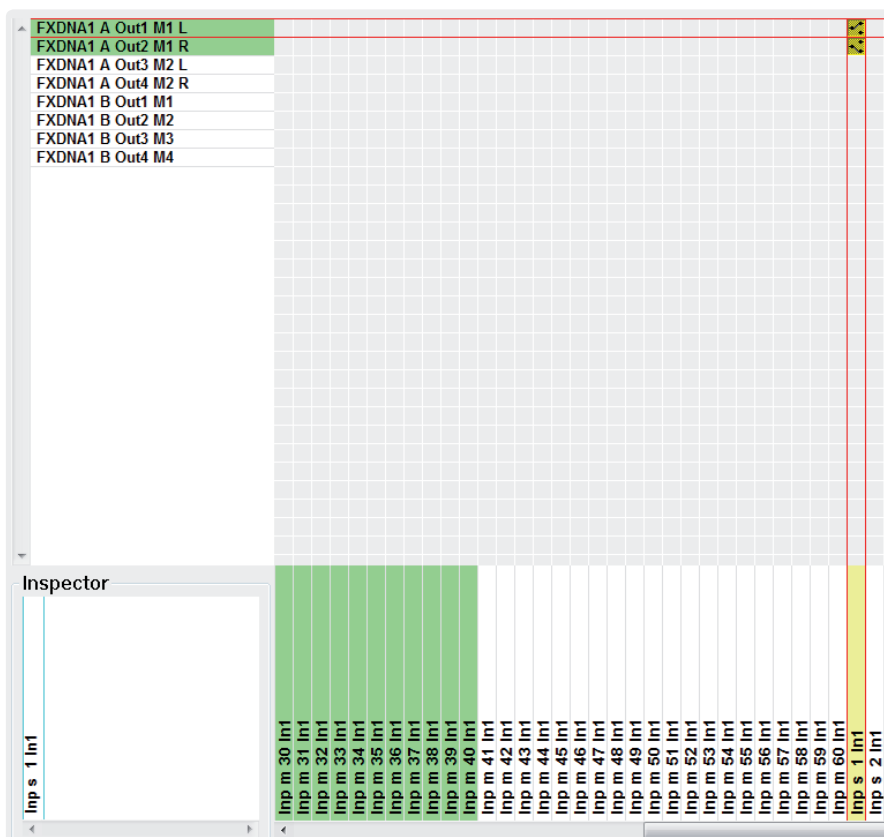

This return channel then gets the blue FX icon instead of the panning icon in the Vistonics touch area (the panning can still be done in the channel ‘misc’ view).

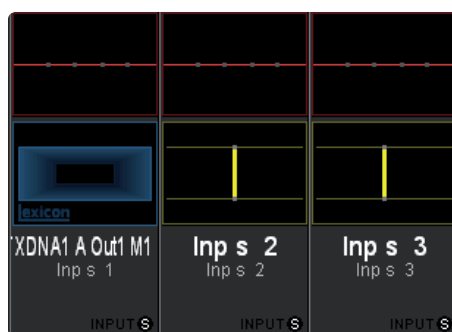

3. Make the desired bus assign for the return channel
4. Operate the FX parameters from the FX icon in the Vistonics touch area.
5. Use Filters and EQ as well as Dynamics of the return channel to further process the effect sound to taste.

These steps can be repeated for as many 'Send-Return' effects as needed for the current title. It is also a good idea to have such setup already as a part of the generic console setup - e.g. stored in a preset or snapshot.

9.3.4 Create Insert Effects

To setup the desk for working with an 'Insert' effect, the following steps of preparation need to be carried out :

1. Patch the effect output port and effect input port into the insert path of the desired channel - either on general patch - or easier - on channel patch page.

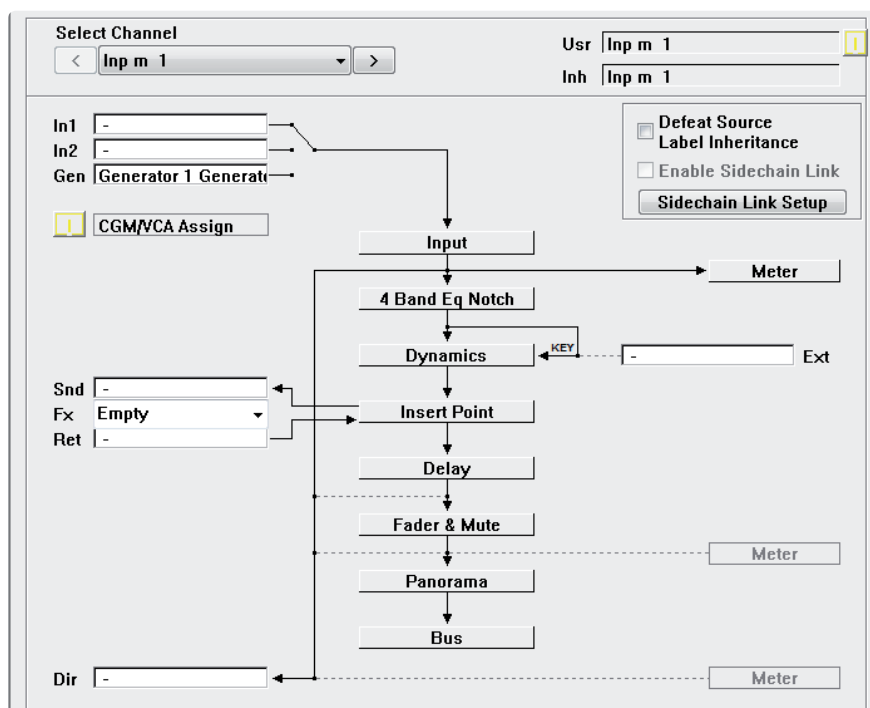

On the channel patch page : only the desired FX block needs to be chosen from the pull-down menu, patching is then done automatically. The pull-down

menu shows all FX machines which are not used yet, and which fit the channel width (mono. stereo, surround) of the channel.

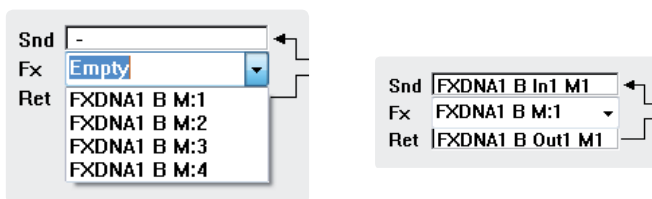

The patching, which is carried out automatically, will then show as follows :

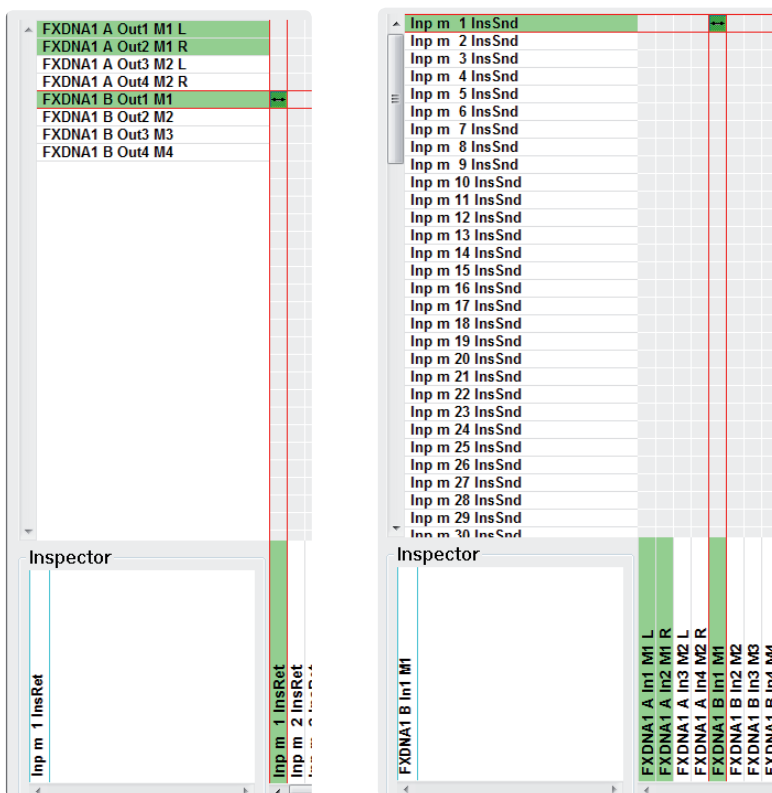

This channel then gets the blue FX icon instead of the panning icon in the Vistonics touch area (the panning can still be done in the channel 'misc' view).

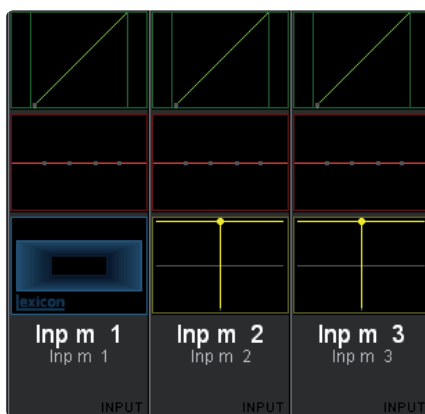

2. Operate the FX parameters from the FX icon in the Vistonics touch area.
3. Activate the channels **Insert On/Off**.
4. Use the effects wet/dry **Mix** parameter to blend the processed signal to the dry signal to get the desired resulting sound.

9.3.5 Loading Effects

When touching into the FX icon area of the Vistonics, a number of blue coloured Vistonics rotaries and icon areas are opened up. This area is always 4 x 4 Vistonics rotaries wide. It is divided into the following areas :

- Category :** The Vista effect types are grouped into categories. Each category has its own set of effect types.
- Effect Type :** Effect types are defined Lexicon factory presets, which can only be loaded. Effect types cannot be stored as user presets - as is normally possible with standalone effect units.
- When effect parameters are adapted to the users needs - they can be stored within a snapshot. Effect types always remain as they originally have been designed by Lexicon. Once any of the parameters have been changed , the **Load** button is changed and becomes a **Clear** button. By pressing **Clear**, all parameters are cleared back to the original Effect type values.
- Mix :** Adjusts the proportion of wet (processed) signal to dry (unprocessed) signal. Ranges from 0% (all dry) to 100% (all wet). With send-return effects, you will leave this at 100% wet, and with insert-effects, the desired dry/wet blend can be created.
- On/Off - Copy/Paste :** Here, the effect processing is switched **On** or **Off**. Please note, that the default state of the processing is **Off** !
The small Vistonics button has the function of a **copy/paste** button. With the **copy/paste** button, effect settings can be copied from effect machine to machine - or into the clipboard library.
- Effect Parameters :** In this area, all effect parameters are displayed and can be controlled from the Vistonics rotaries and buttons.

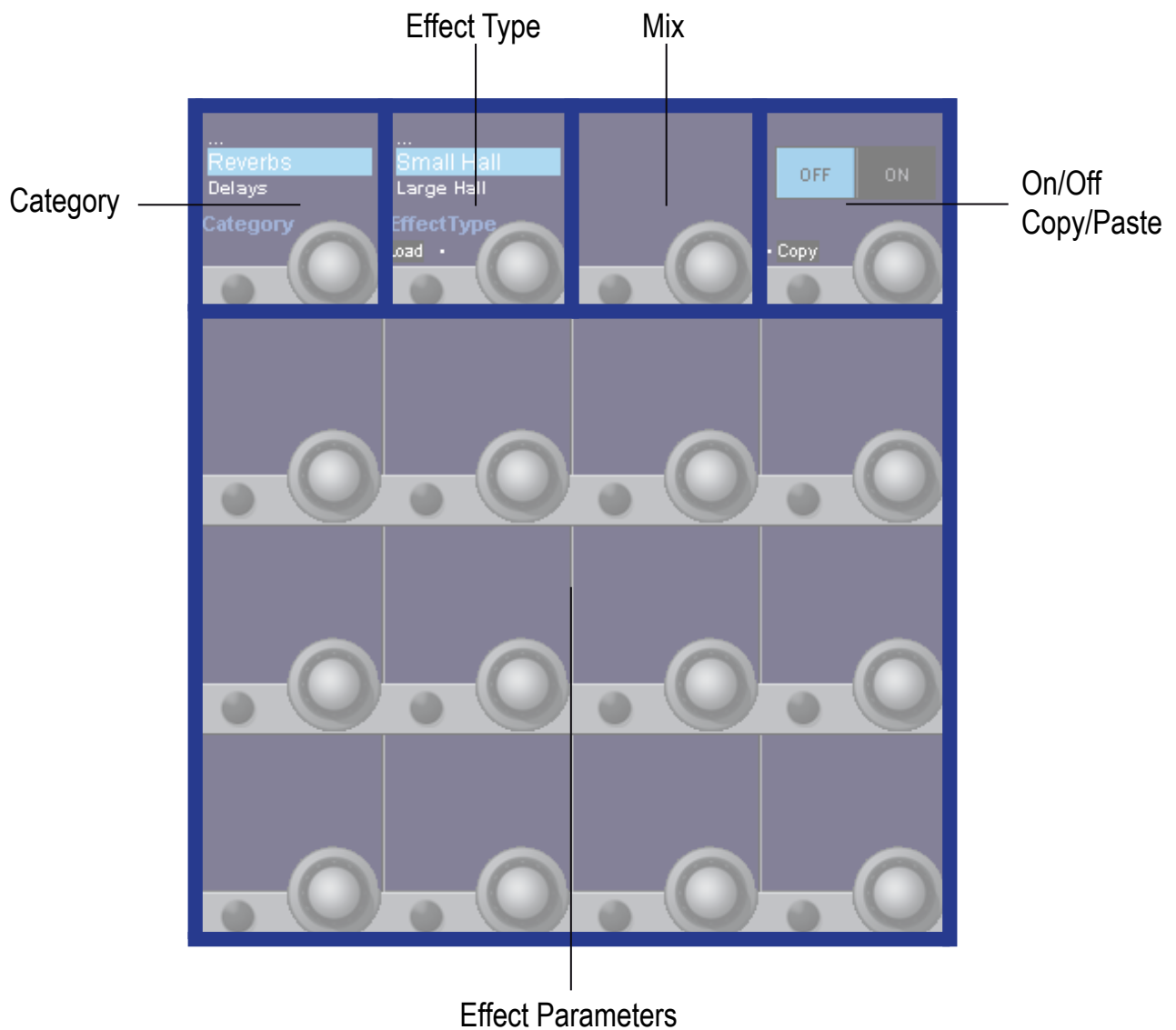

Loading an **Effect Type** : To load an **Effect Type**, first the effect **Category** has to be chosen. With the second Vistonic element, the **Effect Type** can be chosen. The list of **Effect Types** which are available in the chosen category can be scrolled through with the rotary. Once the desired **Effect Type** has been found, it can be loaded by pressing the **Load** button.



As soon as an **Effect Type** is loaded, its control parameters are shown on the Vistonic area. If then the user scrolls further through the **Effect Type** list, the parameters disappear again, but they will come back when the before

loaded **Effect Type** (now marked with an asteriks in front of the name *) is brought into the highlighted area :



This is because the loaded **Effect Type** remains loaded and is running, only until a different **Effect Type** is loaded by pressing the **Load** button.

The same behaviour applies for the **Category** control.

9.3.6 Effect parameters

On/Off : Switches the effect processing On and Off.

Mix : Allows to blend the unprocessed signal with the processed effect signal. Range [0 .. 100] %

These two parameters are available for all Effect Types

9.3.6.1 Reverbs

For the category

Reverbs

the following parameters are available :

Pre Delay : Creates an additional time delay between the source signal and the onset of reverberation. This control is not intended to precisely mimic the time delays in natural spaces, as the build-up of reverberation is gradual, and the initial time gap is usually relatively short. For the most natural effect, the **Pre Delay** values should be set in the range of 10-25 milliseconds. However, if a mix is very busy or overly cluttered, increasing the **Pre Delay** time may help clarify it, and set each instrument apart from each other.

Mid RT and Decay : Controls the amount of time the reverb can be heard. Higher settings increase reverberation times which are usually associated with larger acoustical environments, but can decrease intelligibility. Lower settings shorten reverb times and should be used when a smaller apparent space or a more subtle effect is desired.

Size : **Size** sets the build-up rate of diffusion after the initial period (which is controlled by Diffusion). The **Size** control changes reverb sound from very large to very small. Generally, set this control to the approximate **Size** of the acoustic space being created, before adjusting anything else. The **Size** in meters is roughly equal to the longest dimension of the space. Audio is

temporarily muted when **Size** is changed.

Shape and Spread : In the Hall reverbs, **Shape** and **Spread** work together to control the overall ambience of the reverberation. **Shape** determines the contour of the reverberation envelope. With **Shape** all the way down, reverberation builds explosively, and decays quickly. As **Shape** is advanced, reverberation builds up more slowly and sustains for the time set by **Spread**. With **Shape** in the middle, the build-up and sustain of the reverberation envelope emulates a large concert hall (assuming that **Spread** is at least halfway up, and that **Size** is 30 meters or larger). Low **Spread** settings result in a rapid onset of reverberation at the beginning of the envelope, with little or no sustain. Higher settings spread out both the buildup and sustain.

RT High Cut : **RT HC** sets the frequency above which a 6dB/octave low-pass filter attenuates the reverberated signal. It does not attenuate the reflections. High frequencies are often rolled off with this parameter, resulting in more natural-sounding reverberation. Setting a low frequency for this parameter can actually shorten the reverb time, as it damps the audio as it recirculates.

Liveliness or Hi Cut : Adjusts the amount of high frequency content in the reverberation tails. Higher settings increase high frequency response, creating brighter reverbs; lower settings create darker reverbs with more bass frequency emphasis.

B Boost : Sets the frequency at which the transition from Mid Rt to Low Rt takes place. This control should be set at least two octaves higher than the low frequency you want to boost. For example, to boost a signal at 100Hz, set **B Boost** Frequency to 400Hz. (This setting works well for classical music.) Crossover works best around 400Hz for boosting low frequencies, and around 1.5 kHz for cutting low frequencies.

Ratio : **Ratio** boosts or cuts frequencies below the **B Boost** frequency. The amount of boost or cut required is highly dependent on the material being processed.

Diff : Controls the initial echo density. High settings of Diffusion result in high initial echo density, and low settings cause low initial density. In a real-world situation, irregular walls cause high diffusion, while large flat walls cause low diffusion. For drums and percussion, try using higher Diffusion settings.

ER Time : Adjusts the amount of time before reverb early reflections occur.

ER Level : Adjusts the level of early reflections within the reverb.

Feedb Dly : Changing this parameter changes the resonant frequencies of Plate reverb.

Feedb Level : Adjusts the Plate reverb's presence and prominence.

Boing : This is a unique parameter to the Spring reverb, designed to increase or decrease the amount of spring rattle that is a physical characteristic of spring tank reverbs.

9.3.6.2 Delays

For the category

Delays

the following parameters are available :

- Feedback :** Controls the number of delay repeats by feeding the delay output signal back into the delay input. This creates a series of delay repeats, each slightly attenuated until they become inaudible. Higher settings create more repeats; lower settings reduce the number of repeats. When this knob is turned fully clockwise, it engages Repeat Hold – delay repeats play back in an infinite loop, but no further input signal is introduced into the delay effect. Repeat Hold is available only on Studio, Digital and Pong Delay.
- Lo Cut :** Frequencies below this frequency are attenuated.
- Hi Cut :** Frequencies above this frequency are attenuated.
- Tap 1 & 2 :** The **Tap** parameters provide independent control to the two delay taps in the 2-Tap Delay. Each **Tap** can be set to a percentage of the delay tempo, creating interesting rhythmic delay lines not available in the other delays.
- Level 1 & 2 :** Adjusts the output **Level** of **Tap 1** and **Tap 2**.
- Pan 1 & 2 :** Adjusts the pan position in the stereo field of **Tap 1** and **Tap 2**.
- Tempo / Delay Time :** Controls the length of the **Delay Time** relative to Tempo. If **Duration** is set to **Off**, the **Delay Time** value is displayed. The small Vistonics button allows to chose between **Fine** and **Course** adjustment sensitivity. Can also be controlled by the Tap control button, when assigned to the **USR1** or **USR2** button (see **Tapping** further down in this chapter).
- Duration :** When enabled, this control assigns the **Delay Time** to the **Duration** of a Note. In regard to the **Tempo**, the repeats of the delay can be aligned from a full Note down to the sixteenth of a Note.
- Tap Ratio :** Sets the **Tap Ratio** from 1:1 to many other ratios.
- Tap Swap :** Sets **Tap Swap** from L>R to R>L
- Ducker Thrs :** The Studio and Digital delays effect types offer a “ducking” feature, which causes the delay repeats to attenuate (or get softer) by –6dB when live (or input) signal is present. This allows the delay to remain as an effect, and not clash with the original signal. The higher this value is set, the louder an input signal must be for the ducking to take place.
- Ducker Level :** **Ducker Level** is the level you want the delay to be heard at when signal is present. This provides attenuation (up to 18dB) of the delay signal while a performer is singing or playing to help provide intelligibility. As the performance pauses, the delay signal level returns to its normal setting.
- Smear :** This parameter controls the amount of “**Smear**,” or signal degradation and frequency loss. Particularly evident in the Tape Delay, the higher the setting, the more each delay repeat loses intelligibility compared to the original signal.

Mod Depth : This controls the intensity of modulation, or “depth” in the Modulated Delay. Lower settings produce a more subtle chorus effect, while higher values give a more lush chorusing of the delay repeats.

Tapping : Assigns the Tap control to one of the **USR** buttons on the consoles channel strip.

9.3.6.3 Misc

For the category

Misc

the following parameters are available.

Pre Delay : Determines the amount of offset between the two signals that create the flange effect. Lower values create a tighter effect, higher values result in a more extreme “whooshing” sound.

Depth : Scales the intensity of the effect. This control affects the output of the LFO only. It has no effect on the outputs of the individual waveforms.

Voices : Controls the number of additional Chorus **Voices**.

Regen : Controls the amount of modulated signal being fed back into the input, creating feedback. Higher amounts add more resonance to the signal.

Speed : Sets the **Speed** at which the modulated effect cycles.

Waveform : Selects the wave pattern used by the modulated effect.

Diffusion : Creates a time-smoothing effect similar to **Diffusion** in reverb. **Diffusion** can be a subtle effect to add a little warmth to the chorus.

Lo Cut : Frequencies below this frequency are attenuated.

Phase : Controls whether amplitude or depth change occurs in both left and right outputs simultaneously or alternates between left and right outputs.

Phase Stages : Selects between a 4, 8, or 12 state phase shifter.

ST spread : Increases or decreases the stereo imaging of the Rotary effect.

Drive : Provides overdrive gain to the preamp section of the rotary speaker effect.

Horn min : Sets the minimum speed at which the effect will oscillate.

Horn max : Sets the maximum speed at which the effect will oscillate.

Rotor min : Sets the minimum speed at which the effect will oscillate.

Rotor max : Sets the maximum speed at which the effect will oscillate.

Doppler : Increases or decreases the **Doppler** pitch effect that is created by the physics of a rotating speaker.

- Shift 1 & 2 :** Determines the amount of pitch **Shift** or detune **Shift** from the original signal source. Works best with individual notes.
- Delay 1 & 2 :** Sets the **Delay** time before the pitch shift or detune effect is heard in the Pitch Shift and Detune effects.
- Feedback 1 & 2 :** Adjusts how much of the shifted signal is sent back through the delay line in Pitch Shift and Detune for creating cascading arpeggio type effects.
- Pan 1 & 2 :** Sets the **Pan** position in the stereo field for each shifted signal.

9.3.6.4 Dynamics

For the category

Dynamics

the following parameters are available.

- Frequency :** Selects the **Frequency** range of compression from 1600Hz to 10kHz (the most common frequencies in which excessive sibilance occurs).
- Bandwidth :** Controls the **Bandwidth** or “Quality” (Q) of frequency range. The higher the selected value, the tighter the **Bandwidth**, and less apparent the de-essing effect is.
- Ratio :** Determines the amount of compression, from 1:1 (no effect) to Infinity:1 (complete limiting).

9.3.6.5 Tap Control

On the category **Delay**, most effect types are providing an assignable Tap control.

Tapping : Assigns the Tap control to one of the **USR** buttons on the consoles channel strip. Range [No, USR1, USR2]

By choosing **USR1** or **USR2**, the Tap control can be done with either of the two user buttons on the consoles channel strip, above the fader. The button can then be tapped in order to configure the resulting delay time. As an optical feedback, the button is blinking with the configured time interval.

9.3.7 Copy/Paste

With the **Copy** button, the current effect type, with its current parameter settings is being copied into the clipboard. As now the clipboard library window opens up automatically, the settings can be pasted into the clipboard library.



As an alternative, the settings can also be copied into a channel which is also assigned to an effect. To achieve this, the **Paste** button can be used.



Clipboard Library The clipboard library has been extended by a new tap called **FX**. Here all effect library entries are stored.

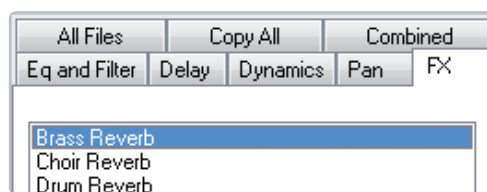

Also a new clipboard library button has been implemented - the copy button next to it can be used to copy library entries into the clipboard, and then into a the desired channel.



Note : Effect settings can only be copied within the same engine setup format (mono, stereo, surround) !
The paste function will only be carried out when the target channel has the same engine format as the source channel, or the setting stored in the clipboard library.
If the format is not matching, the settings are not pasted into the target channel. No error message is displayed - the system will just be ready for a new copy/paste operation.

9.3.8 Snapshot operation

9.3.8.1 Snapshots and Presets

All necessary settings to recreate any use of Vista FX can be stored in snapshots. In more detail, the following data is stored within each snapshot or system preset :

- * the engine setup
- * patching of the effect input- and output ports
- * choice of effect type
- * effect parameter settings of the current state

Note : The recalling of a snapshot or a preset can change the Vista FX engine setup if this snapshot had been previously stored with a different engine setup.

In such a case where the engine setup is changed by a snapshot, unsaved effect parameter settings can be overwritten.

Therefore it is important to keep in mind that the engine setup is of great importance and should be set-up correctly at the start of a session and preferably not be changed anymore.

(Of course - a snapshot recall **undo** operation would bring back the unsaved settings if a snapshot had been recalled by error.)

Important : Manually changing the engine setup when the engine is in use, displays a warning window. When performing the same change via a snapshot recall - *no* warning window is displayed !

9.3.8.2 Static Automation

Global Snapshot filter With the global snapshot filter, effect parameters can be isolated as any other audio parameter in the system. This is done by editing the global snapshot filter, and then touching any of the to be isolated parameter controls. Please note that the isolation of **Category** and **Effect Type** parameters is always linked.



In addition to the effect parameters, also the engine setup - or parts thereof can be isolated. This can be done in the Vista FX engine setup window.

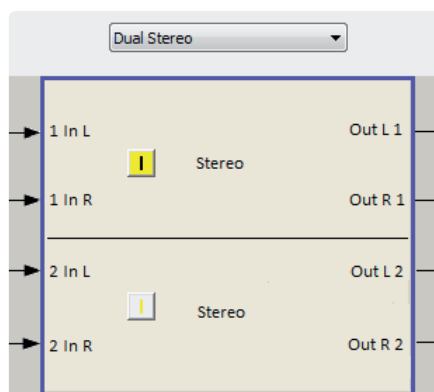

Partial Snapshots Effect parameters can be used in partial snapshots as any other audio parameter in the system. Please refer to chapter 4.4.4 of the Vista operating instructions for more details.

Trim Please note that as a difference to other audio parameters, effect parameters cannot make use of the **Trim** functionality in the static automation.

CueList crossfades Please note that as a difference to other audio parameters, effect parameters cannot make use of the crossfade functionality in the CueList.

9.3.9 Dynamic automation

Effect parameters can only be used in Static Automation mode. In the Dynamic Automation mode, effect parameters cannot be automated against timecode.

9.3.10 Offline operation

By using the VirtualVista application, it is possible to configure Vista FX and set the FX parameters without an actual Vista 1 desk.

9.4 Preset Overview

This table provides an overview over the number of effect types per category and per FX engine setup format.

Category	Mono	Stereo	Surround	
			Single Two In Four Out	Single Four In Four Out
Reverbs	Small Hall	Small Hall	Surround Hall	Surround Hall
	Large Hall	Large Hall		
	Drum Hall	Drum Hall		
	Vocal Hall	Vocal Hall		
	Small Plate	Small Plate		
	Large Plate	Large Plate		
	Drum Plate	Drum Plate		
	Vocal Plate	Vocal Plate		
	Chamber	Chamber		
	Room	Room		
	Ambience	Ambience		
	Gated	Gated		
	Reverse	Reverse		
	Spring	Spring		
Delays	Studio	Studio		
	Modulated	2-Tap		
	Mono	Modulated		
	Pong	Mono		
	Tape	Pong		
	Reverse	Tape		
		Reverse		
Misc	Chorus	Chorus		
	Flanger	Flanger		
	Phaser	Phaser		
	Tremolo	Tremolo		
	Vibrato	Vibrato		
	Rotary	Rotary		
	Pitch Shift	Pitch Shift		
	Detune	Detune		
Dynamics	De-Esser	De-Esser		

